

Heatless High Pressure Desiccant Dryers

Models KTX10 -KTX80

User Guide

aerospace
climate control
electromechanical
filtration
fluid & gas handling
hydraulics
pneumatics
process control
sealing & shielding

Introduction Letter

Dear Customer,

Let us take this opportunity to introduce our company.

Parker is an innovative manufacturer of industrial equipment for compressed air systems.

Our product line includes natural gas dryers, fluid coolers, water separators, air filters, refrigerated air dryers, and heatless and heat reactivated desiccant air dryers. Our products can be found in all corners of the world.

No effort has been spared to provide a comprehensive instruction manual for the use of the **Parker** Dryer. Information is given not only for the user, but also for the technical personnel who may repair the dryer in the event that this is ever necessary. It is recommended that all who will have responsibility for the dryer carefully read all sections of this manual before commencing with the installation.

The most important step is for you as a customer is to call us first at 1-855-5TRYFAF if you are experiencing a problem with your dryer.

If there is a question regarding this manual or our warranty policies and procedures, please call. We would be happy to speak with you.

Thank you for choosing **Parker** products.
Parker Service Department

Contents

1.	Inspection and Installation	4
1.1	Inspection	4
1.2	Dryer Location	4
1.3	Installation	4
2.	Safety and System Precautions	6
3.	General Operation	6
4.	Sequence of Operation	8
5.	Start Up	9
6.	Operational Notes	10
6.1	Variable Cycle Control	10
7.	Shutdown Procedures	11
8.	Demand Cycles	12
8.1	CycleLoc	12
8.2	Dryers Equipped with Ecotronic	12
9.	Maintenance Program	14
9.1	Desiccant Replacement	14
9.2	Inlet and Exhaust Valve Repair	15
10.	Parts (general parts description)	16
11.	Troubleshooting Guide	17
12.	High Humidity	19
12.1	Principle of Operation	19
12.2	System Components	19
12.3	Calibration Procedure	19
12.4	Precautions, Limitations, and Hazards	19
13.	Optional Ecotronic	20
13.1	Quick-Start for Dryers Equipped with Ecotronic	20
13.2	Design and Theory of Operation	20
13.3	Mounting the Probe	21
13.4	Probe to Analyzer Connection	21
13.5	Electrical Connection	21
13.6	Troubleshooting	21
13.7	Ecotronic Display:	22
14.	Optional Pre/After Filters	23
15.	Warranty	25
	Appendix - Spare Parts	27
	Appendix - Drawings	28

1. Inspection and Installation

PRIOR TO INSTALLATION OR START-UP OF DRYER, THIS ENTIRE MANUAL SHOULD BE READ AND UNDERSTOOD.

1.1 Inspection

All Dryers are tested and inspected at the factory prior to shipping. Inspect the dryer carefully upon arrival and note any damage on the freight bill. Uncrate and inspect for concealed damage. File claims with the carrier immediately and notify the manufacturer service department.

1.2 Dryer Location

Locate the dryer in an area accessible for maintenance. The dryer should have minimum 36" clearance on all sides. See dimensional print for specific clearance requirements. The area should be clean, well lighted and have a level, vibration free floor. For standard applications, ambient temperatures should range between 35°F and 100°F. Consult the factory concerning applications outside this temperature range.

1.3 Installation

(See typical installation drawing)

NOTE: All piping and electrical connections should be checked to insure they have maintained their integrity during shipping and installation.

WARNING! Incorrect installation may void warranty! **IMPORTANT!** Sizes above 1500 SCFM require field desiccant charging. Units above 1500 are shipped empty due to weight constraints.

- Coalescing Pre-Filter with auto drain must be installed.
- Standard dryers are designed for 100°F inlet temperature or less.
- Ambient temperatures should be between 35°F and 100°F.
- Dryer should be located in an area accessible for maintenance.
- Location should be clean, cool, with a level, vibration free floor.
- Location of receiver may vary depending on particular conditions and type of compressor.
- Auto drains are required when receiver is mounted up- stream of dryer.

Make the following connections:

1. Inlet piping, including an isolation valve.
2. Outlet piping, including an isolation valve.
3. Coalescing Pre-Filter and Particulate After-filter.

IMPORTANT! Desiccant dryers are designed to remove water VAPOR only!

Locate the coalescing filter as close to the dryer as possible. The air to be dried must pass through a Coalescing Pre-Filter for removal of entrained condensate and oil to prevent fouling of the desiccant. Liquid condensate entering the bed will lead to overloading of the dryer, poor dew point performance, and rapid deterioration of the desiccant. Oil entering the desiccant bed may permanently reduce the capacity of the desiccant.

A Particulate After-filter should be provided to prevent desiccant dust from traveling down stream. Desiccant dust may cause contamination and excessive wear to equipment. Differential pressure indicators should be installed on filters for monitoring of elements. A particulate filter before the dryer and adsorber after the dryer are optional.

4. Auto Drain on Pre-Filter. An Automatic Drain is required on the Pre-Filter and all other upstream collection points to remove condensate.
5. **IMPORTANT!** Bypass piping is necessary. A bubble tight valve should be used for bypass around filters and dryer for servicing.

6. Make required electrical connections to control box. Refer to applicable drawings.

NOTE: Customer to provide short circuit protection for dryer.

7. Access ports should be provided upstream and downstream of the dryer for dew point, pressure, and temperature checks. Periodic checking of the dew point just downstream of the dryer is the best indication of whether the dryer is performing as expected. A High Humidity Alarm or Ecotronic are available as options.
8. All piping should be adequately supported and at least of equal size to the dryer connections.
9. To reduce maintenance and increase dryer efficiency, the exhaust ports can be piped to a location where the exhaust mufflers are not required. The piping **MUST NOT** create any back pressure on the regenerating tower and must be up-sized accordingly. It is recommended that the exhausts be piped separately for ease of troubleshooting and maintenance.

Before any attempt is made to operate the dryer, the operator should thoroughly read and understand this instruction manual. Improper operation will cause poor results from the dryer.

RECOMMENDED INSTALLATION CLEAN DRY, CONTAMINANT FREE AIR

MINIMUM REQUIREMENTS

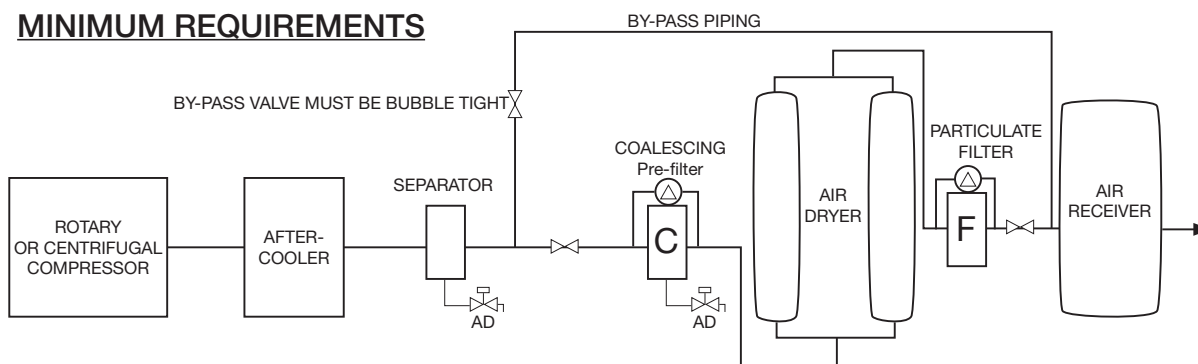

IDEAL INSTALLATION

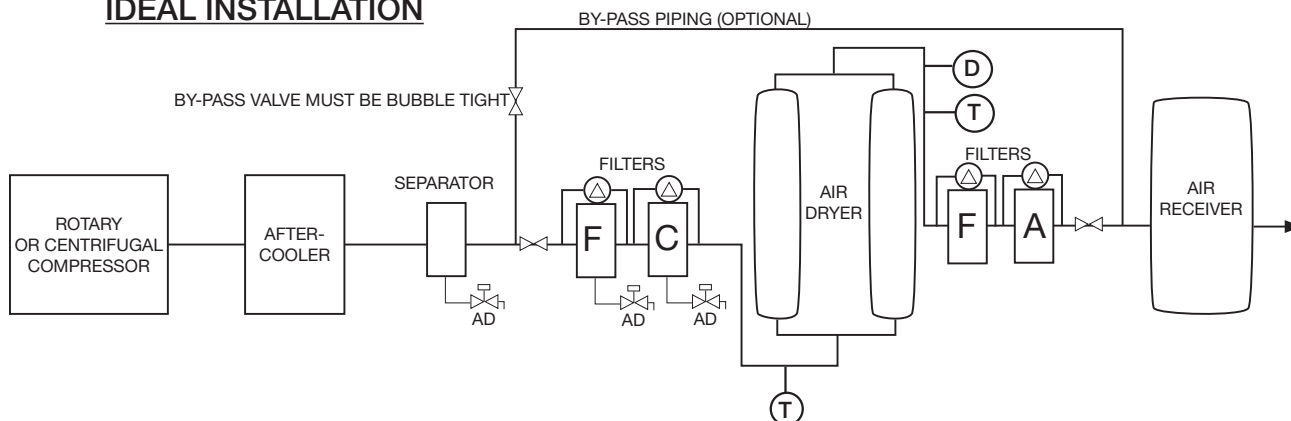

KEY

AD = AUTOMATIC DRAIN
F = PARTICULATE FILTER

C = COALESCING FILTER
A = ADSORBING FILTER
T = TEMPERATURE INDICATOR

D = DEWPOINT INDICATOR/CONTROLLER
Δ = DIFFERENTIAL PRESSURE INDICATOR

2. Safety and System Precautions

- Use EXTREME CAUTION when working in the vicinity of the dryer.
- Relieve pressure before servicing dryer or associated equipment.
- Disconnect power before servicing dryer.
- Use ear and eye protection when in the vicinity of the dryer or exhaust ports, especially if the dryer is being operated without mufflers. Even when mufflers are used, a tower blowing down to atmosphere will raise particles, create more noise than during “normal” operation and may startle an individual not used to this portion of the operation.
- In the case of an overpressure situation there is a safety relief valve on each tower designed to protect the equipment. If these end up pointed in a hazardous direction after dryer installation, they should be piped to safe location.
- Automatic or manual drain valves will eject water, oil, particulates and air under partial pressure when operated. proper precautions must be taken.
- Condensate drainage from compressed air systems may contain oil or other contaminants. Follow all applicable regulations for safe handling and disposal.
- Various component failures could cause large air loss and subsequent pressure drop. Preventive maintenance should be performed to reduce the likelihood of this. If this occurs, bypass the dryer immediately to restore flow and pressure.
- Activated Alumina dust is considered a nuisance dust. Proper precautions should be taken when handling desiccant. For more information and for other types of desiccant, refer to applicable Material Safety Data Sheet. For disposal of used desiccant refer to the applicable regulations.



NOTE: Desiccant contaminated with oil or other foreign substances may be covered under disposal regulations for the contaminant.

3. General Operation

Desiccant dryers work on the principle of adsorption. Adsorption is the process of removing water VAPOR from the air to be dried. All condensed liquid water should be removed from the inlet air stream prior to reaching the dryer by suitable separators, traps, filters, and drains. The dryer can not be burdened with liquid condensate carry-over.

All desiccants are adversely affected by oil, aerosols, dirt, rust, scale or liquid water. Effective pre-filtration in conjunction with automatic condensate drainage is a must for proper dew point suppression and long desiccant life.

The saturated inlet air is alternately cycled through each of the two desiccant beds. One bed is “on-line” at full line pressure and flow, adsorbing water vapor from the saturated inlet air. This is the drying bed.

The other bed is “off-line” at atmospheric pressure (0 PSIG) being regenerated by a depressurized portion of the dried outlet air (purge air). This is the regenerating bed.

The quantity of purge air for a standard pressure dryer is approximately 5% of inlet design flow. This air is taken from the dry air outlet, directed through the purge flow controls, purge check valves, desiccant bed, and finally exhausted to atmosphere to accomplish regeneration. Purge air consumption is typically the largest cost involved with operating a heatless desiccant air dryer. (Purge air is “non-recoverable” and the air system in question must be designed to allow for this usage.)

IMPORTANT! The dryer is designed to remove only water vapor. You might see a small amount of condensate forming at the exhaust due to the Joule-Thomson cooling effect created by the depressurizing air.

Prior to switching a freshly regenerated bed “on-line” to become the drying bed, it must be slowly pressurized from atmospheric pressure to line pressure. This step is called repressurization. Repressurization prevents bed fluidization (lifting) and associated dusting.

Following repressurization, the beds switch functions with the fresh bed now drying and the saturated bed being regenerated.

Note that one bed is always “on-line” drying. Also note that purge air is always being consumed except during repressurization.

This cycle will continue automatically unless the dryer is shut down, operated in the CycleLoc mode or equipped with a Ecotronic.

High Pressure 500 MAWP Technical Specs

MODEL	CAPACITY	PSI	CFM	COLOR	SIZE	DES/TOWER	IN/OUT CON.
KTX 10	50	no gauge	2.5	BLUE	3/32"	12	3/8" NPT
KTX 20	95	no gauge	5	BLUE	3/32"	15	1/2" NPT
KTX 30	200	110	10	BLUE	3/32"	37	3/4" NPT
KTX 40	350	225	18	BLUE	3/32"	75	1" NPT
KTX 50	550	185	28	GOLD	1/8"	120	1 1/2" NPT
KTX 60	800	275	40	GOLD	1/8"	150	1 1/2" NPT
KTX 80	1400	200	70	GREEN	3/16"	300	2" NPT

High Pressure 1000 MAWP Technical Specs

MODEL	CAPACITY	PSI	CFM	COLOR	SIZE	DES/TOWER	IN/OUT CON.
KTX 10	75	-	2.3	BLUE	3/32"	12	3/8" NPT
KTX 20	130	-	4	BLUE	3/32"	15	1/2" NPT
KTX 30	250	90	8	BLUE	3/32"	37	3/4" NPT
KTX 40	400	135	12	BLUE	3/32"	75	1" NPT
KTX 50	750	275	23	BLUE	3/32"	120	1 1/2" NPT
KTX 60	1000	375	30	BLUE	3/32"	150	1 1/2" NPT
KTX 80	1800	375	54	GOLD	1/8"	300	2" NPT

Dryer Outlet Flow

Dryer outlet flow is equal to the dryer inlet flow minus the purge flow.

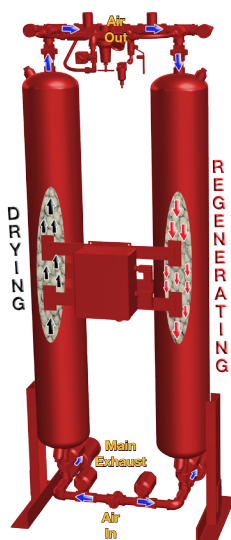

KTX Series Flow Schematic

4. Sequence of Operation

The sequence is controlled by a Solid State Timing and Relay circuit (Sequence Annunciator) which in turn controls five electric solenoid valves. The first four are 3-Way Normally Closed Valves, which supply control air to operate air operated switching inlet and exhaust valves. The Inlet Valves are Normally Open and are closed by supplying dry control air to the valve actuator. The Exhaust Valves are Normally Closed and are closed by supplying dry control air to the valve actuator. The fifth solenoid is the repressurization valve. There are also four mechanical check valves, two outlet and two purge, that allow for proper air flow.

STEP 1- LEFT DRYING; RIGHT REGENERATING

SOLENOID #1 is de-energized sending no air to Exhaust Valve #1 (left side). Exhaust Valve #1 is closed.

SOLENOID #2 is de-energized sending no air to Inlet Valve #1 (left side). Inlet Valve #1 is open. All of the wet inlet air is flowing through Inlet Valve #1. It is dried as it passes through the left tower desiccant bed and exits out the left side Outlet Check Valve to the dryer outlet. The left tower is the Drying tower and the associated pressure gauge should read line pressure,.

At the same time SOLENOID #3 is energized sending a signal to Inlet Valve #2 (right side). Inlet Valve #2 is closed, preventing inlet air flow through the right tower.

SOLENOID #4 is energized sending a signal to Exhaust Valve #2 (right side). Exhaust Valve #2 is open. (NOTE: When exhaust valve first opens, the associated tower will depressurize from line pressure to atmospheric pressure.) Purge air will now flow from the dry air outlet through the Purge Adjusting valve, Purge Orifice and the right hand Purge Check Valve. This purge air then proceeds through the right tower near atmospheric pressure, removing the moisture and exiting the right hand Exhaust Valve and Muffler in vapor form (at no time should the dryer expel any significant amount of liquid water from the muffler; this is a sure sign of trouble in the system). The right tower is the regenerating tower, the associated pressure gauge should read "0" PSIG.

SOLENOID #5 is de-energized and closed.

STEP 2 - LEFT DRYING, RIGHT REPRESSURIZING

While the left tower is still drying, Solenoid #4 will de- energize, relieving the control air signal on the right exhaust valve, returning that valve to its normally closed state. Closing this valve keeps air in the tower, allowing the depressurized part of the dryer to build up pressure or "repressurize". At the same time Solenoid #5 is energized and opened, providing additional air to the tank coming from the purge line to ensure full repressurization of the dryer. Prior to switching towers, all of the gauges should equalize to line pressure.

STEP 3 - LEFT REGENERATING, RIGHT DRYING

Step 3 is the reverse of step 1. Solenoid #1 is energized, providing control air to and opening the left exhaust valve.

Solenoid #2 is energized, providing control air to and closing the left inlet valve. Solenoid #3 and #4 are de-energized. Thus the right inlet is open, and the right exhaust is closed. All the wet air is now flowing **through the right tower and is being dried at line pressure. The left tower is being regenerated at atmospheric pressure. Solenoid #5 is de- energized and closed.**

STEP 4 - LEFT REPRESSURIZING, RIGHT DRYING

Step 4 is the reverse of Step 2. Solenoid #1 de-energizes, allowing the left exhaust valve to close and allowing the dryer to repressurize. In addition, Solenoid #5 energizes providing additional air for repressurization.

NOTE: The Purge Gauge (middle) should read purge pressure, except during repressurization. Purge pressure for standard inlet design conditions is listed on page 4. For other than standard or design conditions consult the factory.

5. Start Up

Please read and understand the entire manual before operating the dryer.

Check and read over wiring diagrams that pertain to your unit and make sure the correct power supply is connected, but do not energize circuit at this time. Provide proper short circuit protection. Follow all applicable codes.

If you do NOT want the dryer to cycle automatically when energized, close the control air isolation valve. If the system has already been pressurized, bleed off the control air pressure by opening the knob on the bottom of the control air filter and reclosing.

Before starting the dryer your compressor should be running, your air system pressurized and the dryer bypassed and not yet pressurized.

SLOWLY open the inlet isolation valve admitting compressed air to the dryer. It is important to pressurize the dryer slowly to prevent fluidization of the desiccant bed. The dryer outlet isolation valve should be closed at this time.

SLOWLY open dryer outlet isolation valve. At this point all valves are in "normal" positions; air is flowing through both towers and downstream.

Close the dryer bypass valve. Bypass valves must be bubble tight to prevent moisture from migrating around the dryer and contaminating the dry air outlet.

CAUTION



It is required that the dryer be started without the mufflers installed. This will expedite removal of excess desiccant dust and prevent premature clogging of the exhaust mufflers.

CAUTION: USE EAR AND EYE PROTECTION WHEN OPERATING DRYER WITHOUT MUFFLERS. EXCESSIVE NOISE WILL BE CREATED. DUST AND PARTICLES FROM THE SURROUNDING AREA MAY BECOME AIRBORNE. OPERATION WITHOUT MUFFLERS EXCEEDS OSHA LIMITS.

Check the Variable Cycle Control setting. It should normally be set at the standard 10 minute, 100% load.

Energize the electrical circuit. If the control air valve is open the dryer will begin to cycle.

If the control air valve is closed, open it to begin the dryer cycle. At this point one tower will exhaust its air to atmosphere. See "CAUTION" statement above.

Check and adjust the setting of the purge pressure indicator or purge flow meter in accordance with the specifications for your dryer. Normally, purge flow is approximately 15% of design flow for the dryer. Note that even if you are operating under a light load the purge can not be reduced if you are operating in the Ecotronic or CycleLoc modes, or a fixed timed cycle other than the standard 10 minute, 100% load cycle.

6. Operational Notes

Never service the dryer or filters without first relieving pressure.

Check all air connections for leaks and tighten as required. Downstream air leaks will affect dew point. Bypass air leaks will affect dew point. Only soft seat bypass valves may be used.

Dryer will not perform without proper pre-filtration, condensate drainage, and purge flow. Dryers may require up to 48 hours of operation to reach normal operating dew points. Therefore, indicators and/or alarms should not be recognized until that time. Applications requiring dew points lower than -40°F, or with nonstandard operating conditions, may require additional time to reach equilibrium.

Exhaust valves and/or exhaust mufflers may have to be cleaned due to dusting in shipping and start-up.

A desiccant dryer should never be suddenly pressurized or depressurized. This will cause fluidizing and dusting of the desiccant bed.

After start-up, some dusting may occur. This will diminish with time. Some dusting may occur with normal operation. The Exhaust Mufflers should be cleaned regularly and an After-filter should be used.

Flow direction is Upflow Drying - Downflow Purge. Switching Failure Alarm is optional and the dryer must be operating over 70 PSI for proper function of the alarm. Dryer valving is “fail-safe” on power loss. This means the inlet valves open and exhaust valves close, allowing system to remain pressurized and air to flow through both towers, and down stream.

The standard dryer has been designed for drying service to 500 PSIG.

The dryer must repressurize before switching.

6.1 Variable Cycle Control

The heatless dryer is equipped with Variable Cycle Control. This control allows for easy adjustment to meet varying plant loading. By using this control, the dryer can be set to one of two standard fixed time cycles, a) standard 100% load (10 minute), b) short cycle -80°F dew point (5 minute). Complete cycle times are given below.

Cycle Times (time in minutes: seconds)

The short cycle will provide a -40°F to - 80°F dew point when operating at or below design conditions. Always set the purge as if you had a full inlet flow when using these cycles. The cycles automatically compensate for the light loading; there is no need to turn the purge down.

CYCLE	TOTAL TIME	PER TOWER TIME		
		DRYING	REGEN.	REPRESS.
100% Load	10:00	5:00	4:15	0:45
75% Load	15:00	7:30	4:15	3:15
50% Load	20:00	10:00	4:15	5:45
Short (-80)	5:00	2:00	2:00	0:30

7. Shutdown Procedures

Isolation

1. Allow dryer to reach repressurization step and fully repressurize
2. While fully repressurized, remove power from the dryer by turning off disconnect.
3. Open bypass pipe.
4. Close outlet isolation valve.
5. Close inlet isolation valve.

Depressurization

1. Open bypass piping.
2. Close outlet isolation valve.
3. Close inlet isolation.
4. Allow dryer to run. The normal cycle will allow both tanks to blow down and depressurize.
5. Disconnect power.
6. With the “Basic Filter Package” dryers, open manual ball valves on filters to allow full depressurization. Leave ball valves on filters open while servicing. Without the “Basic Filter Package”, close control air filter off. Remove nylon tubing from control air filter or any control solenoid. Reopen control air filter to fully depressurize. Leave control tubing off while servicing.

To restart, follow “Start-Up” procedure. **IMPORTANT!** Always remove all pressure and disconnect all power before servicing the dryer.

IMPORTANT! If Ecotronic is installed and the dryer will be out of service for an extended period of time, remove the probe and store in a safe, dry location. The probe will be damaged if exposed to prolonged periods of saturated conditions.

8. Demand Cycles

CycleLoc and Ecotronic are demand cycles available for any heatless dryer. CycleLoc is standard on all heatless dryers. Ecotronic is an option that needs to be purchased. These cycles offer improved operating efficiency over fixed time cycles for applications requiring a -40°F dew point and that will see lighter than design moisture loading. Demand cycles reduce total purge consumption and thus reduce energy usage by tailoring the cycle to actual loading, vs., fixed cycles which assume 100% design loading. Demand cycles can not accommodate for heavier than design loading. It can not shorten the fixed cycle, only lengthen it.

8.1 CycleLoc

The CycleLoc feature is built in to every model. It can be used to interface the dryer with the compressor. The dryer must be able to handle at least full flow of the compressor and the receiver should ideally be located downstream of the dryer. A dry (unpowered) contact closure across the CycleLoc terminals on the Sequence Annunciator will cause the dryer to immediately pause its cycle & stop purging. The contact closure needs to correlate with the compressor stopped or unloaded. When the contact opens the dryer cycle will resume where it left off. Typically a contact on the compressor pressure control is utilized. If a dry normally open (with compressor running) contact is not available, an auxiliary relay will need to be added. The jumper JP1 must be installed for correct CycleLoc operation. Please consult the factory for more information.

8.2 Dryers Equipped with Ecotronic

The Ecotronic is a digital display. The sensor is a thin film gold aluminum oxide design. The Ecotronic observes the outlet pressure dew point of the dryer and digitally displays it. The Ecotronic feature tailors the dryer cycle to actual loading conditions, minimizing energy usage. Without the Dew Point Monitor, the cycle is fixed and “worst case” design conditions are assumed.

The Demand Cycle is accomplished by providing a discrete dry contact closure across the CycleLoc terminals on the Sequence Annunciator. The Variable Cycle Control Switch must be set to 100% load setting for the Ecotronic to work. If the dryer is maintaining a good dew point AFTER the first five minutes of drying, the Ecotronic will override the fixed cycle and keep the current tower “on-line” until it is saturated to design loading (switch point value), usually -40°F. If this occurs, the “off- line” bed which has just finished being regenerated will repressurize and be ready to go “on-line”. The CycleLoc light on the Sequence Annunciator and the Ecotronic will be on at this time. Once the dew point degrades to the switch point value, the freshly regenerated bed will go “on-line”, and the saturated bed will depressurize and begin regeneration. Note that the Ecotronic cannot shorten the cycle. The drying tower will always undergo a design regeneration cycle of 4 minutes and 15 seconds. The Ecotronic can only compensate for under-loading, not overloading conditions.

If there is any error with the Ecotronic or probe, the Ecotronic will not function. There is also a Ecotronic On/Off switch located in the control enclosure. If this switch is turned off, the dryer will operate in the fixed time cycle. The Ecotronic will continue to display dew point. The Ecotronic is fully programmed and wired at the factory if ordered with the dryer.

For dryer start-up, all that is normally required is sensor installation. The sensor should be installed after dryer has been allowed to purge the initial dusting caused by transportation or filling. The probe isolation valve should be fully opened after installation to allow operations at full line pressure for correct reading of pressure dew point. A coil of capillary tubing is provided to allow a small sample flow over the sensor and prevent ambient moisture from infiltrating the system. Check the bleed periodically to ensure it is not clogged.

Following sensor installation, allow the sensor to stabilize at the line pressure for four hours prior to attaching the sensor cable.

Failure to follow the above precautions may result in sensor failure not covered by warranty.

Please note that upon installation the sensor will be saturated at atmospheric conditions. Even if the dryer is producing a good dew point, it will not be indicated immediately as it will take a period of time for the sensor to dry out and come to equilibrium with the system.

The sensor will also become saturated to atmospheric conditions if the air system is shut down and allowed to depressurize. Upon restart of the system, the dew point may appear to be poor, even though the dryer may be producing clean, dry air.

Although the probe can be exposed to occasional, brief periods of liquid saturation, it can not be exposed to continuous wet conditions. If your dryer is over loaded and saturated, or if it will be shut down for an extended period of time; remove or isolate the probe until the problem is resolved. Refer to the separate Ecotronic section for more detailed information.

IMPORTANT! Demand Control Cycles can not be used together! Please consult factory to ensure proper use of any of the nonstandard cycles.

9. Maintenance Program

Daily

1. Check dew point or humidity level if instrumentation is available. Any difficulty with the dryer will result in poor dewpoint performance.
2. Check for correct purge setting and air flow from purge exhaust.
3. Check gauge readings and sequence of operation through complete cycle.
4. Check auto drain operation on pre-filter, separator and receiver. A manual drain valve installed (in addition to the automatic drain) at these points will ease checking of the automatic drains.
5. Ensure there is no back pressure in the regenerating tower.

Weekly

1. Check differential pressure across pre-filter and after-filter elements. Replace if required.
2. Check and maintain operating conditions; pressure, flow, and temperature within the design parameters of the dryer.

Semi-Annually

1. Inspect desiccant for physical condition. Desiccant from a freshly regenerated bed should be white, dry to touch and of consistent size and shape.
2. Check and clean mufflers. This may be required often under certain conditions or if back pressure develops. Mufflers can be cleaned by blowing backwards through them with clean, dry air. Mufflers may require replacement if severely clogged, or after a few cleanings.
3. Replace pre-filter and after-filter elements.
4. Clean automatic drain.
5. Replace control air filter element.
6. Check and slowdown safety valves. Refer to manufacturer's instructions.
7. Clean dryer.

Annually

1. Inspect and rebuild inlet and exhaust valves.
2. Return Ecotronic probe and chip for recalibration, if applicable.

9.1 Desiccant Replacement

CAUTION: Activated Alumina Desiccant dust is considered a nuisance dust. Proper precautions should be taken. Refer to "Material Safety Data Sheet".

1. Remove pressure and power from dryer.
2. Open drain ports on bottom of tanks.

3. Catch desiccant in suitable container. Close drain ports and open top fill ports.
4. Refill with recommended type, size and quantity of desiccant. Wrap sides of the chambers while filling so desiccant will pack tightly. Some settling may be required to fit specified amount in tank. One tank size may be used for multiple models, do not be concerned if tank is not full.
5. Consult Material Safety Data Sheet and all applicable regulations for disposal of desiccant. Disposal of desiccant contaminated with oil or other substance may require different procedures than desiccant replaced strictly due to aging.

NOTE: Use only manufacturer supplied desiccant which is a high capacity, high quality desiccant designed and sized for the dryers.

9.2 Inlet and Exhaust Valve Repair

1. Shutdown the dryer as described in this manual. Remove pressure from the dryer Make certain there are no “pockets” of pressure isolated by various valves. Open the bleed valve on the bottom of the control air filter bowl.
2. Loosen the compression fitting attaching the control tubing to the valve body. Carefully move the tubing aside.
3. Disassemble valve to clean or repair. Repair kits are available for most valves.
4. Reassembly is reverse of disassembly. Replace all O-rings, gaskets and components.

10. Parts (general parts description)

- A. **DESICCANT** - An adsorbent used for drying air or gases. Proper quantity, size and type are necessary.
- B. **INLET VALVE** - Normally Open Air Operated Switching Valves used to direct the air flow through the towers.
- C. **EXHAUST VALVE** - Normally Closed Air Operated Switching valves used to exhaust purge air, hold air in tower on line, and exhaust air from tower ready to be regenerated.
- D. **OUTLET AND PURGE CHECK VALVES** - Valves that allow full flow in one direction and no flow in the other are used in conjunction with the inlet and exhaust valve to accomplish desired flow of process and purge air.
- E. **SAFETY RELIEF VALVES** - Furnished on each tower to protect the vessels from overpressure situations. Setting is indicated on valve.
- F. **PURGE EXHAUST MUFFLER** - Furnished to reduce exhaust noise during purge and blow down for personnel protection and to comply with OSHA standards. Mufflers offer no benefit to the operation of the dryer and are a maintenance concern. Consideration should be given to locating the exhaust in an area where mufflers would not be required.
- G. **PURGE CONTROL REGULATOR OR VALVE** - Furnished to adjust and regulate purge flow for regeneration.
- H. **SOLID STATE CONTROLLER/SEQUENCE ANNUNCIATOR PANEL** - Furnished for cycle control. Outputs operate 5 electric solenoid valves. Provides for Variable Cycle Control. Provides interface with optional Ecotronic and has integral lights to provide visual cycle indication. Has built-in automatic drain control. All hard wired connections, including field power connection, are made to this board.
- I. **TOWER PRESSURE GAUGES** - Furnished to read pressure in each tower. On-line tower should read line pressure, regenerating tower should read "0" PSIG.
- J. **PURGE FLOW INDICATOR (center gauge)** - Furnished to indicate and monitor proper purge flow.
- K. **CONTROL SOLENOIDS** - (4) 3-way normally closed electric solenoid valves, operated by the solid state controller, that in turn provide a control air signal to operate the inlet and exhaust valves.
- L. **REPRESSURIZATION SOLENOID (Variable Cycle Control Bypass)** - A solenoid valve provided to ensure tower repressurization before switching, even at low flows.
- M. **CONTROL AIR FILTERS** - Filters control air, which is taken from the dryer outlet, to protect the control solenoids from desiccant dust. Also protects Ecotronic Probe where applicable.

11. Troubleshooting Guide

Exhaust Valve on Drying or Repressurizing Tower Leaking	1. Valve dirty	Clean valve
	2. Defective diaphragms or O-rings	Repair or replace
	3. Leaking control solenoid	Repair or replace
Excessive Pressure Drop	1. Pre-filter dirty	Replace element
	2. After-filter dirty	Replace element
	3. Desiccant dirty	Replace desiccant
Unit Does Not Fully Repressurize	1. Purge rate too low	Adjust purge
	2. Exhaust valves leaking	See above
	3. Repressurization solenoid faulty	Replace solenoid
	4. Purge or repressurization orifice plugged	NOTE - On newer units, orifice is a different color than the rest of the unit
Back Pressure in Regenerating Tower	1. Clogged mufflers	Clean, repair or replace
	2. Check valves leaking	Clean, repair or replace
	3. Purge flow too high	Adjust
	4. No output from controller	Replace fuse or controller
Inlet or Exhaust Valves not functioning	1. Bad diaphragms or O-rings	Rebuild valves available kits or replace
	2. No control air	See below
	3. Control solenoids defective	Repair or replace
	4. No output from controller	Repair or replace
No Control Air at Inlet or Exhaust Valves	1. Control air shutoff valve closed	Open
	2. Control air filter dirty	Replace Element
	3. Leak in control air tubing	Repair
	4. Control solenoid defective	Repair or replace
	5. No output from controller	Replace fuse or controller
Constant Bleed From Control Solenoid Top Exhaust Port	1. Associated inlet or exhaust valve defective	Rebuild or replace
	2. Dirty or defective control solenoid	Clean or replace
Constant Bleed From Vent On Inlet	1. Defective diaphragms or O-rings	Rebuild or replace
Exhaust Valve on Drying or Repressurizing Tower Leaking	1. Valve dirty	Clean valve
	2. Defective diaphragms or O-rings	Repair or replace
	3. Leaking control solenoid	Repair or replace
Excessive Pressure Drop	1. Pre-filter dirty	Replace element
	2. After-filter dirty	Replace element
	3. Desiccant dirty	Replace desiccant
Unit Does Not Fully Repressurize	1. Purge rate too low	Adjust purge
	2. Exhaust valves leaking	See above
	3. Repressurization solenoid faulty	Replace solenoid
	4. Purge or repressurization orifice plugged	NOTE - On newer units, orifice is a different color than the rest of the unit
Back Pressure in Regenerating Tower	1. Clogged mufflers	Clean, repair or replace
	2. Check valves leaking	Clean, repair or replace
	3. Purge flow too high	Adjust
	4. No output from controller	Replace fuse or controller

Inlet or Exhaust Valves not functioning	1. Bad diaphragms or O-rings	Rebuild valves available kits or replace
	2. No control air	See below
	3. Control solenoids defective	Repair or replace
	4. No output from controller	Repair or replace
No Control Air at Inlet or Exhaust Valves	1. Control air shutoff valve closed	Open
	2. Control air filter dirty	Replace Element
	3. Leak in control air tubing	Repair
	4. Control solenoid defective	Repair or replace
	5. No output from controller	Replace fuse or controller
Constant Bleed From Control Solenoid Top Exhaust Port	1. Associated inlet or exhaust valve defective	Rebuild or replace
	2. Dirty or defective control solenoid	Clean or replace
Constant Bleed From Vent On Inlet	1. Defective diaphragms or O-rings	Rebuild or replace

12. High Humidity

12.1 Principle of Operation

The High Humidity Alarm (HHA) are circuits designed to function in conjunction with a Hygrosensor to provide on/off control for compressed air dryers. The HHA can also provide an alarm when humidity conditions exceed or go below a fixed setpoint.

Operation of the controller is based on relay actuation at a predetermined resistance value. The resistance of the humidity sensor (a Dunmore-type lithium chloride element) varies inversely proportional to the relative humidity to which it is exposed. The controller supplies a constant excitation voltage to the sensor and the change in resistance is measured. When the relative humidity reaches the selected setpoint (-20°F, -29°C), the controller detects the corresponding resistance and activates a single pole, double throw relay.

The controller is set to activate at a predetermined resistance value by using a setplug whose resistance corresponds to the sensor resistance at a particular relative humidity condition (-20°F).

CAUTION



12.2 System Components

POWER: 12-/220 VAC + 10%, 50-60Hz, 1 Watt DIMENSIONS: PC Board 3.5 x 2.75 x 1.1 inches
OPERATING TEMPERATURE: + 15°F (-9.4°C) to 140°F(60°C) STORAGE TEMPERATURE: -40°F (-40°C) to +200°F (93°C).

CAUTION! HHA IS POWERED UP DURING THIS PROCEDURE. USE CAUTION NOT TO TOUCH LIVE EXPOSED TERMINALS.

12.3 Calibration Procedure

1. Remove the sensor input terminals and replace it with the appropriate setplug.
2. Adjust potentiometer P1 to the midpoint between the relay “pull-in” and “drop-out”.
3. Replace the setplug with the sensor. The unit is now ready for operation.

12.4 Precautions, Limitations, and Hazards

The HHA Controller uses 115 VAC. Avoid contact with exposed terminals when performing set point adjustment.

Never test the sensor with an ohmmeter or other DC measuring device. To do so will permanently damage the sensor.

Do not expose sensors to humidity's at which condensation is likely to occur, nor to sprays or water droplets in ducts and air exhausts.

Do not expose sensors to air stream carrying dust, soot, or other containments, unless properly protected by baffle, 200 by 200 mesh screen, cellophane, or tissue paper wrap to prevent impingement of particles on the sensing surfaces.

13. Optional Ecotronic

13.1 Quick-Start for Dryers Equipped with Ecotronic

The following steps are all that is normally required for start-up of dryers equipped with the Ecotronic System. Refer to the remainder of this manual for more detailed information on Ecotronic Operation.

Please read entire Dryer Manual before proceeding.

1. The unit is prewired to the dryer at the factory with the exception of the probe to cable connection at this time.
2. Purge the sample line of any desiccant dust by opening isolation valve. Use caution as pressurized air and dust will blowout off open port.
3. Close isolation valve. Install the probe in the 1/2" SAE port provided. Hand tighten the nut, and then using a wrench tighten the nut another turn and a half.
4. Slowly open the isolation valve to the full open position. It is imperative that the isolation valve be fully open so that the Ecotronic reads pressure dew point. The sample line is fitted with coiled capillary tubing to control the sample air flow. There must be continuous flow to obtain an accurate reading.
5. Following exposure of probe to line pressure, allow it to stabilize for 4 hours prior to connecting the probe cable. Failure to do so may cause premature failure not covered by warranty.
6. After 4 hours connect the probe to the analyzer via the cable provided.
7. The probe and dryer system may require 48 hours or more to reach desired dew point on initial or subsequent start-ups. High humidity alarms should be disregarded until this time.
8. The unit is normally factory set for -40°F (-40°C) switching and -20°F (-29°C) high humidity alarm.
9. Dry contacts rated at 120/250 VAG, 2.5 amps are provided for remote annunciation of high humidity alarm. A linear 4 to 20mA output corresponding to dew point is also provided.
10. Both the switching and high humidity relays are fail-safe. In the event of probe or electronics failure, the dryer will switch to the fixed cycle, the high humidity alarm will activate, and a diagnostic code will flash on the digital display.
11. Although the probe can be exposed to brief periods of liquid saturation, it can not be exposed to continuous wet conditions. Remove probe to dry location if these conditions exist.

It is recommended that the probe be returned to the factory once a year for recalibration to standard gases in order to maintain accuracy. Contact factory for further information.

13.2 Design and Theory of Operation

The Ecotronic is a microprocessor controlled Pressure Dew Point (PDP) analyzer. The Ecotronic consists of a gold/aluminum oxide sensor probe and an electronics module. The microprocessor calculates moisture (PDP) that is compensated for temperature and pressure and controls the switching and alarm set points.

Total dew point control can be obtained with the switching relay, alarm relays, and an optional linear, isolated 4 to 20mA output corresponding to the PDP.

13.3 Mounting the Probe

Probes are shipped loose. Do not misplace or damage the probe. The probe consists of more than 2/3 the value of the unit. When Ecotronic is ordered with a dryer, a sample line for the probe is built into the dryer outlet. When ordered for field installation, a sample line will be provided that must be installed in the piping where it is desired to measure the dew point. A 1/2" NPT port is typically required.

The probe should be installed vertically with the sensing tip pointing down. Horizontal mounting is also acceptable. Proper mounting will allow moisture to drip off the tip if a saturation condition occurs.

Mounting the probe directly in line could possibly cause damage.

Allow the dryer to cycle at least 3 times prior to installing the probe in order to avoid contamination by desiccant dust. Open the isolation valve and purge the sample line of any collected desiccant dust. Use caution as pressurized air and dust will then be expelled to atmosphere. Close the isolation valve and install the probe. Insure that the tip of the probe does not touch the pipe wall. Adjust the ferrule to the desired insertion length (do not tighten ferrule on the sensing tip) and tighten the compression fitting as follows:

- Hand-tighten the nut.
- Then, using a wrench, tighten the nut one and one-half turns.

Slowly open the isolation valve to full open position. It is imperative that the isolation valve be fully open so that the Ecotronic reads pressure dew point. The sample line is fitted with coiled capillary tubing to control the sample air flow. There must be continuous flow to obtain an accurate reading.

Following exposure of probe to line pressure, allow it to stabilize for 4 hours prior to connecting the probe cable. Failure to do so may cause premature failure not covered by warranty.

13.4 Probe to Analyzer Connection

After 4 hours, connect the probe to the analyzer via the cable supplied.

The Ecotronic ordered with a dryer will have the cable prewired to the analyzer. If the unit is being field installed, pay close attention to the cable wire colors and make sure the cable shield is grounded. Refer to applicable electrical.

13.5 Electrical Connection

No other connections are required for factory installed units.

For field installation refer to applicable drawings and make required power and control corrections. Note that control wiring for units equipped with switching failure alarm is different than those not so equipped.

Dry contacts are provided for remote annunciation of High Humidity. A linear 4 to 20mA output is provided for continuous monitoring of the dew point.

The instrument can now be turned on at any time. However, it should be noted that stable readings will occur after the sample has come to equilibrium. This can take several hours to several days depending on the moisture content of the flow, desiccant, piping and probe.

13.6 Troubleshooting

BLANK DISPLAY (with the power turned on) - this is an indication of a power line fault.

Check the power connection. If the display is still blank, the display is at fault. Consult the factory.

Probe Recalibration and Replacement

- The recommended calibration interval is one year to maintain accuracy (+/- 1%).
- Consult the factory for recalibration procedure.

13.7 Ecotronic Display:

The display is factory set to indicate either degrees °F or degrees °C.

There are four Set Points. To view depress the ‘down’ arrow (right button). Each time the down arrow pushbutton is depressed, the display will cycle to the next set point value. The Set Point number is displayed followed by the set point value. For example: ‘SP2” followed by, ‘-20’ This cycling will continue until the ‘down’ arrow pushbutton is depressed to advance to the next Set Point.

The four Set Points are:

Display	Description	Default = °F or °C	Indication
SP3'	DEWPOINT ALARM	(Default = -°20 / -°28.9)	RED 'HIGH HUMIDITY' PILOT LIGHT
SP4'	OPEN PROBE ALARM	(Default = -°199.9 / °128.8)	RED 'HIGH HUMIDITY' PILOT LIGHT
SP2'	NOT USED	(note - the display LED will illuminate at a 'zero' or '+' dew point	AMBER Power Save 'ON'
SP1'	POWER SAVE MODE ON	(Default = -40° / -40°)	AMBER Power Save 'ON' PILOT LIGHT

To go back to displaying Dew Point, depress the ‘PROG’ pushbutton (left button).

CHANGE SET POINT DEFAULT TO NEW VALUES:

The Set Points can be changed to any desired value. To change to a new set point value, depress both the ‘PROG’ (left button) and the ‘down’ arrow (right button) simultaneously. The display will go into the ‘Program Set Point’ mode. (NOTE: once into the program mode it is necessary to complete advancing through all the steps to save any changed values). There are four steps to each Set Point. These steps are as follows:

Display	Setting Description	Display Default	Push Buttons to Change Value
SPx	SET POINT VALUE	-20° (see above)	▲or▼then ‘PROG’ to advance
do	DELAY-ON MAKE	0	▲or▼then ‘PROG’ to advance
dob	DELAY-ON BREAK	0	▲or▼then ‘PROG’ to advance
HySe	HYSTERESIS	0	▲or▼then ‘PROG’ to advance

If no change is desired at any step within process, simply depress the ‘PROG’ to advance through the program cycle. Once all four Set Points (and four settings per set point) are completed, the display will go back to displaying the dew point. If no activity is detected while in the program mode, after 15 seconds the unit will go back to displaying Dew Point with no changes to the preceding step prior to depressing the ‘PROG’ pushbutton.

OTHER SETTINGS:

All other settings (4-20mA ‘IN’, and 4-20mA ‘OUT;’) have been factory set. **IMPORTANT:** it is possible to inadvertently access these program menus, it is advisable to not change any range settings; as this would make the unit not respond correctly. For Ecotronic units with three (3) wire probes, the following information will apply to the 4-20mA outputs on J3, pin 16 =(+) and pin 17 =(-). The Dew Point range is as follows:

DEGREE °F	-148 @ 4mA through to +68 @ 20mA
DEGREE °C	-100 @ 4mA through to +20.0 @ 20mA

14. Optional Pre/After Filters

Receiving and Inspection

Upon receipt of the filter(s), immediately check for damage that may have occurred during shipping. If there is any damage, do not install or attempt to repair the filter. File a claim with the shipping company and contact either your local distributor or contact manufacturer's customer service department for further instructions. Since the filter is shipped F.O.B. factory, the carrier is not covered by filter warranty.

WARNING! FAILURE OR IMPROPER SELECTION OR IMPROPER USE OF THE PRODUCTS AND/OR SYSTEMS DESCRIBED HEREIN OR RELATED ITEMS CAN CAUSE SEVERE INJURY OR PROPERTY DAMAGE.

Installation

All filters, coalescer, adsorbers should be installed at the highest pressure point available, and as near as possible to the equipment to be protected with a drip leg immediately upstream. The coalescer should be in a visible and easily accessible location for periodic draining and maintenance.

All filters should be selected based on compressed air flow rate and pressure, not on the basis of pipe size. If new piping is installed, pipe size must also be selected on the basis of flow rate and pressure. Be sure all piping is supported.

Filters should be piped in accordance with the instruction tags, flow arrows, and "IN" and "OUT" labels supplied with the filter. See recommended system installation diagram in this manual.

Before filter installation, the customer may wish to install a pressure relief device in accordance with paragraphs UG-125 through UG-136 of the ASME Boiler and Pressure Code section VIII-division I. You may also wish to check with local requirements.

Filter Bypass

A three-valve bypass around the filter is recommended so that the elements can be changed without shutting down the branch or complete air system. Piping should not be allowed to place any stress on the filter connections.

For systems that can not tolerate unfiltered air during element replacement, a second filter should be installed in the bypass. See installation diagrams.

Element Replacement

As the filter is used, the replaceable element will become plugged with particles from the air stream. The gradual buildup of these particles will cause an ever increasing pressure drop through the element. This pressure drop will be indicated by the differential pressure gage that is provided with the filter. The filter should be changed when the indicator suggests the element is plugged. The increasing pressure drop will cause a reduction in the air system efficiency.

WARNING! COMPLETELY VENT INTERNAL AIR PRESSURE TO ATMOSPHERE BEFORE DISASSEMBLING FILTER.

Cast Filters

- Relieve internal pressure by opening the manual vent valve.
- Disconnect drain lines at manual and automatic drain valves (if applicable).
- Unscrew filter collar from head of filter and remove bowl.
- Unscrew retaining cap from rod.
- Remove used filter element and dispose of in accordance with local regulations.
- Clean any debris from bowl and insert new element.
- Examine condition of O-rings
- Screw retaining cap on rod until snug without damaging the new element.
- Reattach drains.
- Repressurize slowly to prevent element damage and leak check.

Filter Drainage

The filter sump in the bottom of each filter is a critical part of the filtration system. The liquids that accumulate here must be drained at regular intervals, in order to prevent the condensate from being re-in trained in the filtered air. A typical drain system should consist of an automatic drain ball valve. (Applies to coalescing filters only.)

Outdoor Installation

Heat tracing of sump area and drain lines are required for installations that are exposed to ambients of 32°F or lower.

Application Notes

FILTERING FACTS:

- All compressed air is “saturated” with moisture unless its pressure dew point has been reduced by drying. Filtration does not change the moisture or oil dew point of the air. Filtration or coalescing ONLY removes particles, liquid and aerosols. They can not remove vapors.
- Coalescing should be done at the lowest temperature possible.
- Oil and water vapors condense as the temperature is lowered.

Element	Initial PSID	Replacement Element at PSID
Coalescer - Dry New	1.5	N/A
Coalescer - Wet New	2.5	6 - 8
Adsorber	1	4 - 6
Particulate	1.5	4 - 6

15. Warranty

The Parker Warranty Philosophy...

Warranty can be defined as a protection of investment. Warranty policies can come in all different shapes and sizes; however, the most important attribute to a successful policy is its fairness to all parties involved. This brings us to the explanation of components that make up Parker Warranty Philosophy.

Warranty Procedure...

Parker believes in giving the most expedient service possible to our customers. In order to accomplish this the most important step for our customer is to call us (1-855-5TRYFAF) immediately in the event of a potential warranty situation. The phone call serves several purposes;

- It puts the customer in direct communication with the factory and assures them of factory support.
- It helps us to diagnose the problem and perhaps remedy it over the phone. This saves everyone time. In most cases we can determine the root cause of the failure through a simple phone call.
- It helps us to assess any parts that may be needed for repair. This eliminates time and travel by a service company making one trip with parts in hand.
- It helps us to determine situations non related to the dryer. After the phone call has been placed, and if service is necessary, we will authorize a service house in close proximity to the customer.

It is important when a call is placed to us for a potential warranty situation, that the following information be provided:

- . Model and serial number.
- . Start-up date.
- . Company name.
- . Dryer location.
- . Phone number.
- . Contact person.
- . Specific nature of complaint

(Diagnostic code, high dew point, etc.). Important: Parker reserves the right to deny any claim submitted without our knowledge and proper authorization.

Warranty Parts and Returns...

In the event a part is required to complete a warranty repair the following steps will occur:

1. A standard parts order must be placed with our customer service department (1-855-5TRYFAF), along with a purchase order number.
2. The customer that placed the order will receive an invoice for the part. This is for memo billing only. The invoice will also contain a Return Authorization Number (RMA).



WARRANTY REGISTRATION

IMPORTANT! E-Mail Today!

Fold and Seal and your Service Warranty will be registered immediately.
We are here to help. For more information on service or installation call the Service Department at 1-855-587-9323.

Email to: fafwarranty@parker.com

Model # _____ Serial # _____

Company _____

Address _____

City _____ State/Province _____ Zip _____

Telephone _____ Contact _____

Title _____ Department _____

Date Purchased _____ Date installed _____

Purchased From _____

COMMENTS

Please indicate a response on a scale of
(1) being the lowest to (5) being the highest

Condition of Arrival _____

Ease of Installation _____

Ease of Start-Up _____

Product Quality _____

Technical Assistance _____

Clarity of Instruction/Warranty Manual _____

FINAL OPERATION CHECK LIST

Inlet air temperature is _____

Inlet PSIG is _____

The dew point temperature controller reads between _____
and _____

Air compressor HP _____, or Max SCFM is _____

Is the dryer a minimum of 3' from any structure on all sides?
Yes No

The Y strainer for drains has been cleaned after first 8 hours of
operation Yes No

What are your thoughts on the operation of the dryer?

Why did you choose this manufacturer?

What could we do better?

Appendix - Spare Parts

Appendix - Drawings

Worldwide Filtration Manufacturing Locations

North America

**Compressed Air Treatment
Filtration & Separation/Balston**
Haverhill, MA
978 858 0505
www.parker.com/balston

**Finite Airtek Filtration
Airtek/domnick hunter/Zander**
Lancaster, NY
716 686 6400
www.parker.com/faf

Finite Airtek Filtration/Finite
Oxford, MI
248 628 6400
www.parker.com/finitefilter

**Engine Filtration &
Water Purification
Racor**
Modesto, CA
209 521 7860
www.parker.com/racor

Holly Springs, MS
662 252 2656
www.parker.com/racor

Beaufort, SC
843 846 3200
www.parker.com/racor

Racor – Village Marine Tec.
Gardena, CA
310 516 9911
desalination.parker.com

Parker Sea Recovery
Carson, CA
310 637 3400
www.searecovery.com

**Hydraulic Filtration
Hydraulic Filter**
Metamora, OH
419 644 4311
www.parker.com/hydraulicfilter

Laval, QC Canada
450 629 9594
www.parkerfarr.com

**Process Filtration
domnick hunter Process Filtration**
Oxnard, CA
805 604 3400
www.parker.com/processfiltration

Madison, WI
608 824 0500
www.scilog.com

Phoenixville, PA
610 933 1600
www.parker.com/processfiltration

**Aerospace Filtration
Velcon Filtration**
Colorado Springs, CO
719 531 5855
www.velcon.com

Europe

**Compressed Air Treatment
domnick hunter Filtration & Separation**
Gateshead, England
+44 (0) 191 402 9000
www.parker.com/dhfn

Parker Gas Separations
Etten-Leur, Netherlands
+31 76 508 5300
www.parker.com/dhfn

Hiross Zander
Padova Business Unit
Padova, Italy
+39 049 9712 111
www.parker.com/hz

Hiross Zander
Essen Business Unit
Essen, Germany
+49 2054 9340
www.parker.com/hz

**Engine Filtration &
Water Purification
Racor**
Dewsbury, England
+44 (0) 1924 487 000
www.parker.com/rfde

Racor Research & Development
Stuttgart, Germany
+49 (0)711 7071 290-10
www.parker.com/rfde

**Hydraulic Filtration
Hydraulic Filter**
Arnhem, Holland
+31 26 3760376
www.parker.com/hfde

Ujala Operation
Ujala, Finland
+358 20 753 2500
www.parker.com/hfde

Condition Monitoring Centre
Norfolk, England
+44 (0) 1842 763 299
www.parker.com/hfde

Parker Kittiwake
West Sussex, England
+44 (0) 1903 731 470
www.kittiwake.com

Parker Procal
Peterborough, England
+44 (0) 1733 232 495
www.kittiwake.com

**Process Filtration
domnick hunter Process Filtration**
Birtley, England
+44 (0) 191 410 5121
www.parker.com/processfiltration

Parker Twin Filter BV
Zaandam, Netherlands
+31(0)75 655 50 00
www.twinfilter.com

Asia Pacific

Australia
Castle Hill, Australia
+61 2 9634 7777
www.parker.com/australia

China
Shanghai, China
+86 21 5031 2525
www.parker.com/china

India
Navi Mumbai, India
+91 22 651 370 8185
www.parker.com/india

Parker Fowler
Bangalore, India
+91 80 2783 6794
www.johnfowlerindia.com

Japan
Tokyo, Japan
+81 45 870 1522
www.parker.com/japan

Parker Techno
Osaka, Japan
+81 66 340 1600
www.techno.taiyo-ltd.co.jp

Korea
Hwaseon-City
+82 31 359 0852
www.parker.com/korea

Singapore
Jurong Town, Singapore
+65 6887 6300
www.parker.com/singapore

Thailand
Bangkok, Thailand
+66 2186 7000
www.parker.com/thailand

**Latin America
Parker Comercio Ltda.
Filtration Division**
Sao Paulo, Brazil
+55 12 4009 3500
www.parker.com/br

Pan American Division
Miami, FL
305 470 8800
www.parker.com/panam

Africa

Aeroporto Kempton Park, South Africa
+27 11 9610700
www.parker.com/africa

