

CORROSION

IN HYDRAULIC SYSTEMS

Corrosion is the destructive attack of metals due to chemical reactions within an environment. The naturally occurring event causes significant financial, environmental, and safety problems.

GLOBAL ECONOMIC IMPACT >

According to reports by the National Association of Corrosion Engineers (NACE), the cost of corrosion is staggering on a global scale. In addition, these costs typically do not include individual safety or environmental consequences.



COST OF CORROSION
GLOBALY
\$2.5
TRILLION

Source: <http://impact.nace.org/executive-summary.aspx>

BREAKDOWN BY SECTOR >

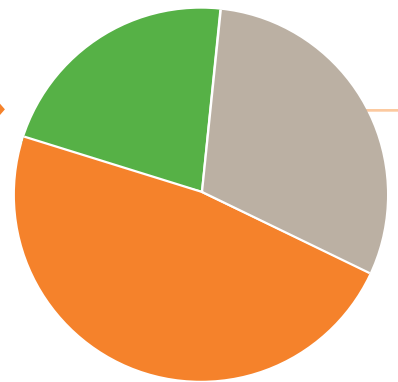

Source: <http://impact.nace.org/documents/Nace-International-Report.pdf>

▶ AGRICULTURE AND FORESTRY

▶ SERVICES

- Transportation and Storage
 - Rail
 - Road
 - Automobile
 - Ships/marine
 - Air
 - Power transmission
 - Waterways
- Accommodation and Food Service
- Information and Communications

▶ INDUSTRY

- Mining
- Manufacturing
- Construction
- Electricity, Gas, Steam, AC Supply
- Water Supply, Sewage, Waste Management

CORROSION SPREADS FAST >

Corrosion can happen at any time in nearly every environment. Once it starts, corrosion can spread rapidly in an uncontrolled manner. It can migrate quickly across components, jeopardizing processes, equipment, and uptime. Therefore, it is essential to avoid component corrosion from the onset.

FACTORS THAT INFLUENCE CORROSION

One or more of the following cause corrosion

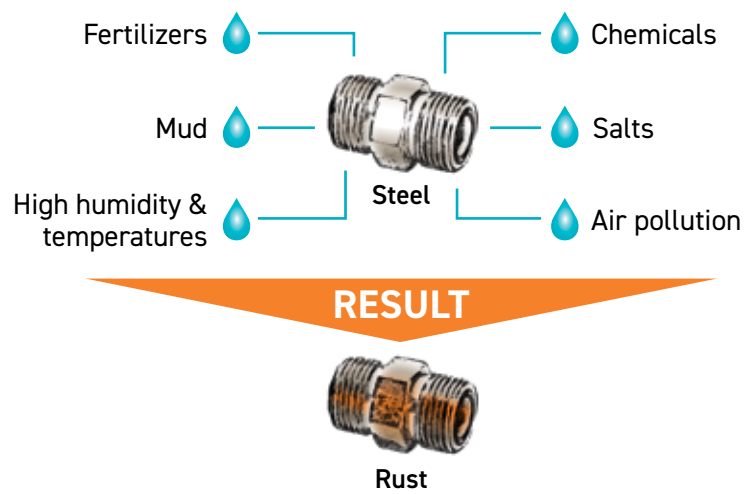

CONSEQUENCES OF CORROSION >

The true cost of corrosion goes beyond just replacing a tube fitting or adapter. It can mean serious issues for your equipment and operation:

- Frequent maintenance
- Downtime
- More difficult maintenance
- Aesthetic quality concerns
- Corrosion migration to adjacent components
- Potential warranty claims

COMBATING CORROSION

WITH NEW TECHNOLOGY

Parker ToughShield™ Plus

Zinc-Nickel Plating for Tube Fittings & Adapters

Parker's most recent advancement in plating technology is patent-pending ToughShield™ Plus. As Parker's global standard plating, you now get the same high-quality tube fittings and adapters with significant improvement in corrosion resistance.

INDEPENDENT LAB TESTING PERFORMANCE

ToughShield Plus fights red corrosion up to:

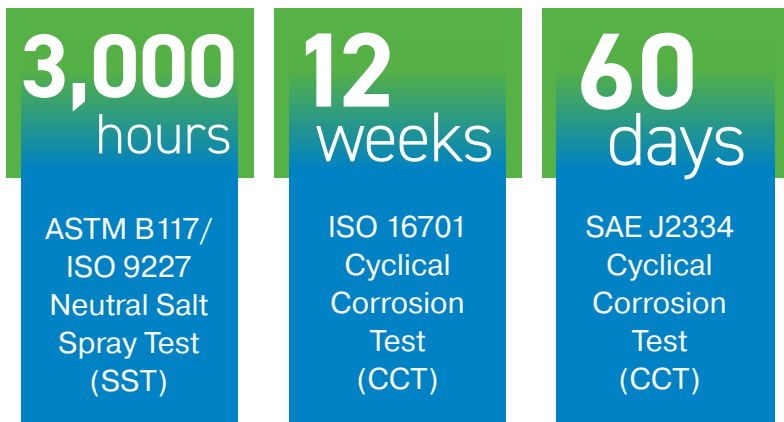

PROVEN PERFORMANCE AND VALUE

- Less frequent and easier maintenance
- Reduced downtime
- Extended fitting service life
- Decreased corrosion migration to adjacent components
- Reduced warranty claims



THE PARKER DIFFERENCE

ToughShield Plus zinc-nickel plating forms a protective shield against costly corrosion.

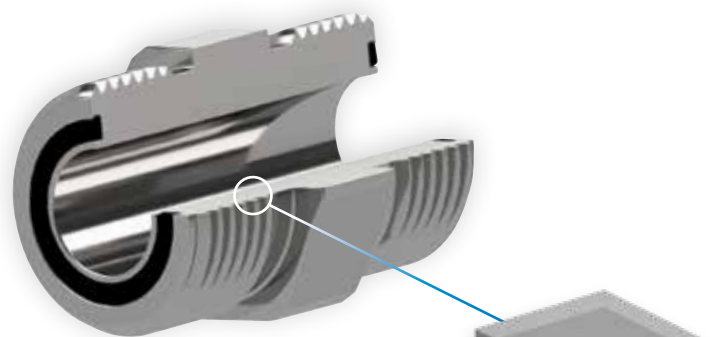

Innovative topcoat offers superior friction/assembly control

Hexavalent chromium-free passivation layer

Proprietary patent-pending ToughShield Plus zinc-nickel alloy plating technology

Steel base material (Substrate)

Visit www.toughshield.com to learn more