



---

## Externally Heated & Blower Purge Desiccant Dryers

Models TWP/TWB201 – TWP/TWB7501

User Manual

---

These instructions must be thoroughly read and understood before installing and operating this product. Failure to operate this product in accordance with the instructions set forth in this manual can lead to unsafe operating conditions and may void warranty. For additional information, refer to this manual or contact the factory for recommendations. Please have the dryer serial number and model ready when contacting the factory.

### **Factory Contact Information**

Phone 1-800-343-4048

For pricing, availability, and purchase orders: [GSForders@parker.com](mailto:GSForders@parker.com)

For technical support and aftermarket: [FAFparts@parker.com](mailto:FAFparts@parker.com)

For product applications and technical sales: [FAFquotes@parker.com](mailto:FAFquotes@parker.com)

## Contents

<b>Safety and Precautions</b>	4
<b>Installation</b>	5
<b>General Operation</b>	8
<b>Flow Schematics</b>	10
<b>Wiring Diagrams</b>	17
<b>Start Up</b>	26
<b>Timing Configuration</b>	27
<b>Manual Stepping</b>	28
<b>Controller Display &amp; Operation</b>	28
<b>Communications</b>	48
<b>Shutdown</b>	56
<b>Maintenance</b>	56
<b>Spare Parts Lists</b>	58
<b>Troubleshooting</b>	79
<b>Technical Specifications</b>	81

## SAFETY AND PRECAUTIONS



Use **EXTREME CAUTION** when working in the vicinity of the dryer. Adhere to all warning labels on dryer. Relieve pressure before servicing dryer or associated equipment.



Disconnect power before servicing dryer.

Always wear eye protection when in the vicinity of the dryer. Ear protection is recommended, especially if the dryer is being operated without mufflers. Even when mufflers are used, a desiccant vessel blowing down to atmosphere will raise particles, create more noise than during “normal” operation and may startle an individual not familiar with this portion of the operation.

The dryer uses heat to regenerate the desiccant. Any dryer surface may reach temperatures up to 350°F. Do not touch hot surfaces. Partial insulation is provided to maximize dryer performance. The standard insulation does not provide complete personnel protection or 100% thermal efficiency.



The emergency stop button will cut off 120V control voltage only. Supply voltage is not disconnected.

In the case of an overpressure situation there is a safety relief valve installed on each desiccant vessel designed to protect the equipment. If the valves are pointed in a hazardous location to operators after dryer installation, they should be piped to a safe location.

Dryers are designed for fail safe operation. In the event of a power failure, the inlet valves will fail in the open or last position and the exhaust valves will fail closed. Compressed air will continue to flow through the dryer. When power is restored, the cycle will continue on from where it left off at the time of the power loss.

Automatic or manual drain valves will eject water, oil, particulates, and air under partial pressure when operated. Proper precautions must be taken.

Condensate drainage from compressed air systems may contain oil or other contaminants. Follow all applicable regulations for safe handling and disposal.

Various component failures could cause large air loss and subsequent pressure drop. Preventative maintenance should be performed to reduce this possibility. If this situation occurs, bypass the dryer immediately to restore flow and pressure.

Oil in the desiccant bed combined with high regeneration temperature may create a potential for fire or explosion. Proper cooling, pre-filtration, and condensate drainage must be maintained to reduce the possibility of oil contamination.

Activated alumina dust is considered a nuisance dust. Proper precautions should be taken when handling desiccant. For more information and for other types of desiccant, refer to the applicable Safety Data Sheet. For disposal of used desiccant, refer to the local codes and regulations.

**NOTE:** desiccant contaminated with oil or other foreign substances may be covered under disposal regulations for the contaminant.

Heated dryers are designed with a cooling cycle after heated regeneration to alleviate high temperatures from the regenerated desiccant and vessel. It is normal for residual heat to remain in the regenerated vessel. Temperatures of 200-350°F may be seen at switchover. The residual heat will dissipate quickly once the tower is online at full flow. Downstream piping and components must be suitable for the elevated temperatures.

***DOWNSTREAM AIR TEMPERATURE MAY EXCEED 200°F FOR A DURATION OF 15 MINUTES AFTER DRYING VESSEL SWITCHOVER! TEMPERATURE CAN EXCEED 350°F AT LOWER FLOW!***

## INSTALLATION

Inspect the dryer upon receipt for any damage that may have occurred during shipment.

Each desiccant dryer is supplied with a User Manual, dryer general arrangement drawing, and ASME pressure vessel U1A data reports (where applicable).

The initial charge of desiccant is included with the dryer. Ensure vessels are filled with desiccant prior to startup. Models 2001 and larger include desiccant shipped separately in 25 lb bags to be installed by the user at the site. Smaller dryers are shipped with desiccant installed.

Exhaust mufflers are supplied for each dryer. A quantity of two mufflers are shipped attached to the dryer, uninstalled, for models 201 and larger. Mufflers should not be installed until after startup to allow excess desiccant dust to be cleared from the dryer and not prematurely close the new mufflers.

The dewpoint sensor (optional) is shipped in a small container attached to the dryer. Take care not to misplace before installing.



If placed in storage, place in a location protected from the environment. If stored outside, it is recommended that the dryer be underneath a shelter and be shrink wrapped or crated to protect against rain. Desiccant dryers should not be stored in a location exposed to freezing temperatures or direct sunlight. Dryers designed for outdoor use should not be placed outside until ready for operation. All plugs and flange covers should remain in place until the dryer is ready to be installed. Desiccant bags should remain in original closed packaging and be stored in a dry environment until dryer is ready for operation. Dryers with desiccant installed should be stored in a dry environment.

The dryer should be moved using a pallet jack or fork truck. Desiccant dryers are tall and top heavy. Use caution while moving the equipment to avoid tipping over. Many dryers have desiccant vessels equipped with lifting lugs. **DO NOT USE THE VESSEL LIFTING LUGS TO LIFT THE DRYER.** They are only used to lift an empty vessel and are not designed to hold the weight of the equipment.

Install in an area with an ambient temperature range of 40°F to 100°F. The area should be well lit and ventilated. It is recommended to leave a minimum of four feet around all sides of the dryer for maintenance. Ensure that the dryer is stable and properly secured on a vibration free floor before operation.

If installed outdoors, the desiccant dryer should be installed in an area protected from the effects of weather. Locate under a roof if possible. Avoid direct sunlight so that the control display does not become damaged and can be clearly read. If installed in an area with below freezing temperatures, proper heat trace and freeze protection must be added to the equipment.

There are several connection points on the dryer. Make sure each connection is made prior to startup.

1. **Air in connection** – Will be marked on the dryer with a tag. Use piping suitable for the pressure and temperature class.
2. **Air out connection** – Will be marked on the dryer with a tag. Use piping suitable for the pressure and temperature class.
3. **Prefilter drain connection** – Located near the prefilter and labeled. Drain discharge is under pressure equal to the system and must use piping suitable for the pressure and temperature class if piped to another location. A coalescer type prefilter must be installed before the desiccant dryer if not supplied with the dryer. It is critical to the performance of the dryer to protect the desiccant bed from oil bulk moisture contamination.
4. **Dewpoint sensor (Power Lock options only)** - Located near the prefilter and labeled. Drain discharge is under pressure equal to the system and must use piping suitable for the pressure and temperature class if piped to another location. A coalescer type prefilter must be installed before the desiccant dryer if not supplied with the dryer. It is critical to the performance of the dryer to protect the desiccant bed from oil bulk moisture contamination.

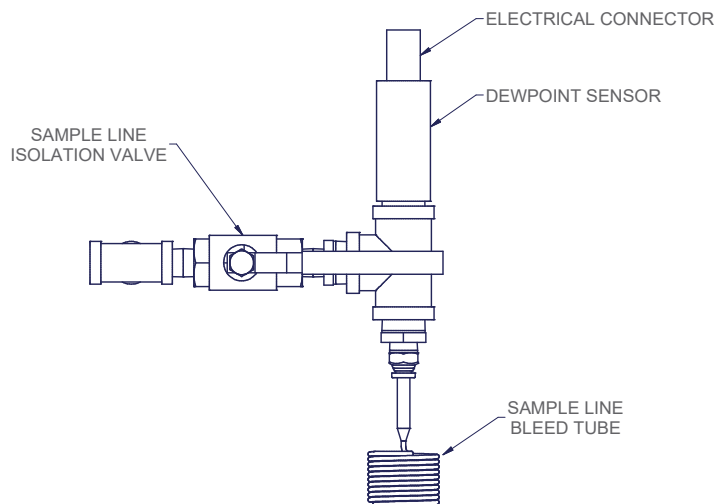

5. **Power supply** – Bring power to the high voltage panel. Verify voltage, phase, and frequency of power supply matches dryer design by checking the serial label. Check that power supply is sufficient for amp rating on serial label. Short circuit protection is the responsibility of the owner.

Mufflers are included with the dryer to reduce noise level only. They are not required for normal operation and should not be installed for initial startup. The exhaust may be piped to another location to further reduce noise, but must not restrict purge air or dryer performance will suffer. The following considerations must be taken when piping the exhaust.

**TO 10 FEET, SAME PIPE DIAMETER SIZE AS DRYER EXHAUST VALVE.**

**TO 25 FEET, ONE PIPE DIAMETER SIZE LARGER THAN DRYER EXHAUST VALVE.**

**TO 50 FEET, TWO PIPE DIAMETER SIZES LARGER THAN DRYER EXHAUST VALVE.**

**TO 100 FEET, THREE PIPE DIAMETER SIZES LARGER THAN DRYER EXHAUST VALVE.**

Each elbow installed in the exhaust piping is equivalent to 10 feet of pipe. If the exhaust piping is vertical, a drip line must be installed to remove moisture. It is recommended to pipe the exhausts separately for ease of maintenance and troubleshooting.

It is highly recommended to install bypass valves and piping around the dryer and filters to use during routine dryer maintenance.

## RECOMMENDED INSTALLATION CLEAN DRY, CONTAMINANT FREE AIR

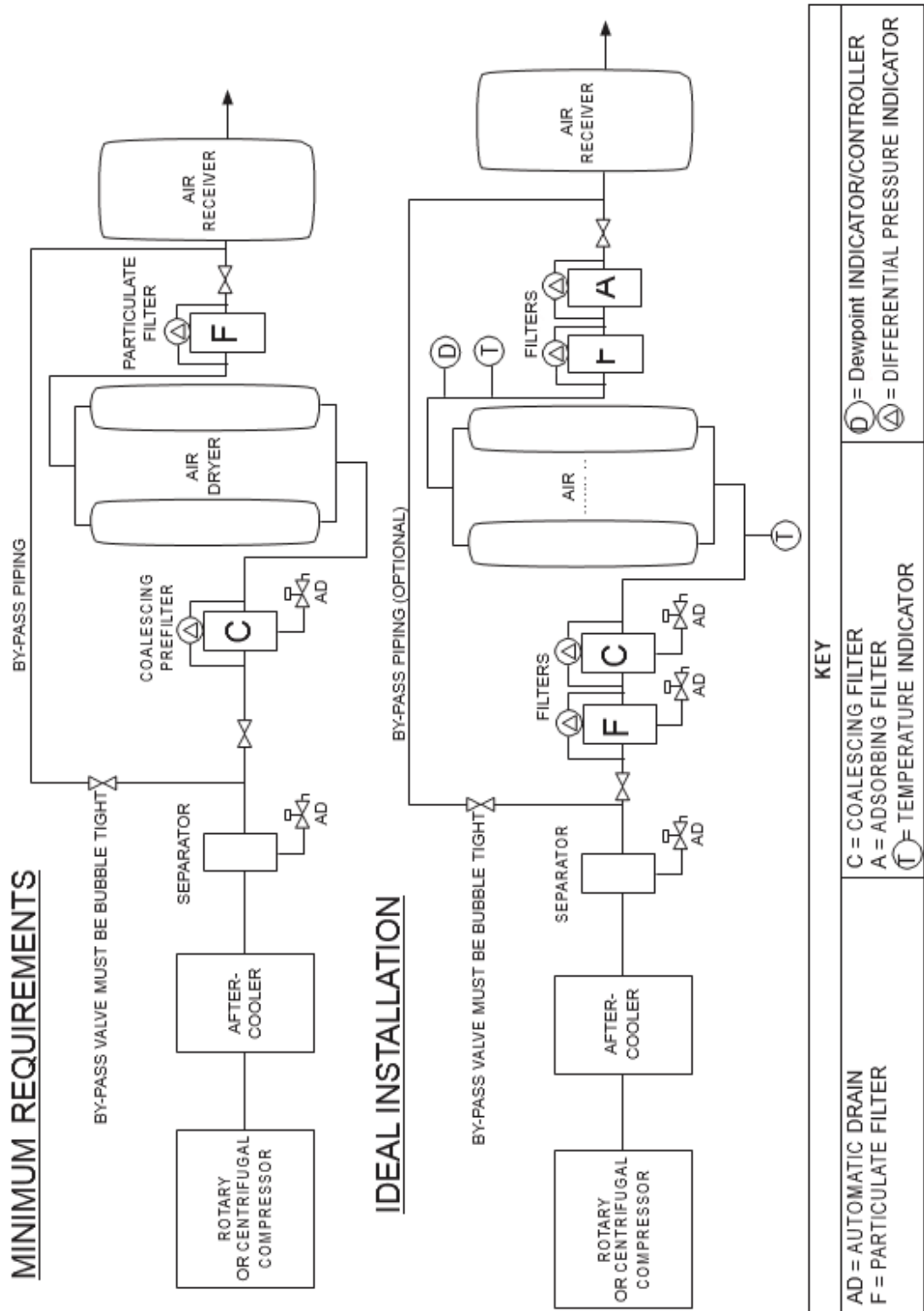

## GENERAL OPERATION

The externally heated and blower purge desiccant dryers are designed to remove moisture in water vapor form, from compressed air to yield dewpoints of -40°F or better. The twin tower design allows constant drying of compressed air through one adsorption vessel while the other vessel desiccant bed regenerates by using heated dry purge air.

Compressed air is directed through the inlet valve and up through the drying desiccant vessel where moisture is adsorbed by the desiccant. The low dewpoint dry air is then directed through the outlet check valve and downstream for use.

For externally heated dryers, regeneration of the saturated desiccant vessel bed is begun by blowing down the saturated vessel bed. The quick change from line pressure to atmosphere causes moisture to detach itself from the desiccant and be exhausted. The regeneration cycle is continued by directing 8% of the dry compressed air through a purge valve and orifice. The purge air is expanded to atmosphere, passed across an electric resistance heater where the air temperature is elevated to 400°F, then passed down through the saturated bed heating the desiccant. Adsorbed moisture is released from the desiccant, and then exits the dryer through the exhaust valve and muffler. Once heated regeneration is complete, the heater is powered off and cooling begins. Dry purge air continues to pass through the regenerated bed, cooling it to reduce the air temperature spike downstream and allow the newly regenerated bed to readily adsorb moisture again after switchover.

For blower purge dryers, regeneration of the saturated desiccant vessel bed is begun by blowing down the saturated vessel bed. The quick change from line pressure to atmosphere causes moisture to detach itself from the desiccant and be exhausted. The regeneration cycle is continued by the blower pulling in ambient air and passing this low pressure wet air across an electric resistance heater. The air temperature is elevated to 400°F, then passed down through the saturated bed, heating the desiccant. Adsorbed moisture is released from the desiccant, and then exits the dryer through the exhaust valve and muffler. Once heated regeneration is complete, the heater is powered off and cooling begins. The blower continues to pass air through the regenerated bed, cooling it to reduce the air temperature spike downstream and allow the newly regenerated bed to readily adsorb moisture again after switchover. A stream of dry purge air in the amount of 2% may also be used after blower cooling to reduce the dewpoint spike at switchover caused by using wet ambient air with the blower.

Once regeneration is completed, the offline desiccant vessel is slowly pressurized to system pressure. The dryer is ready for switchover, at which point compressed air will be directed through the newly regenerated desiccant bed for drying and the opposite desiccant vessel begins regeneration. This cycle continues automatically.

The dryer inlet, exhaust, and repressurization valves are controlled by solenoid actuated control valves, which are controlled by the dryer PLC. The PLC operates opens and closes the valves using a programmed timing sequence. The PLC is equipped with various timing cycles to maximize the dryer efficiency. It is also possible to extend the drying cycle time using the dewpoint demand function.



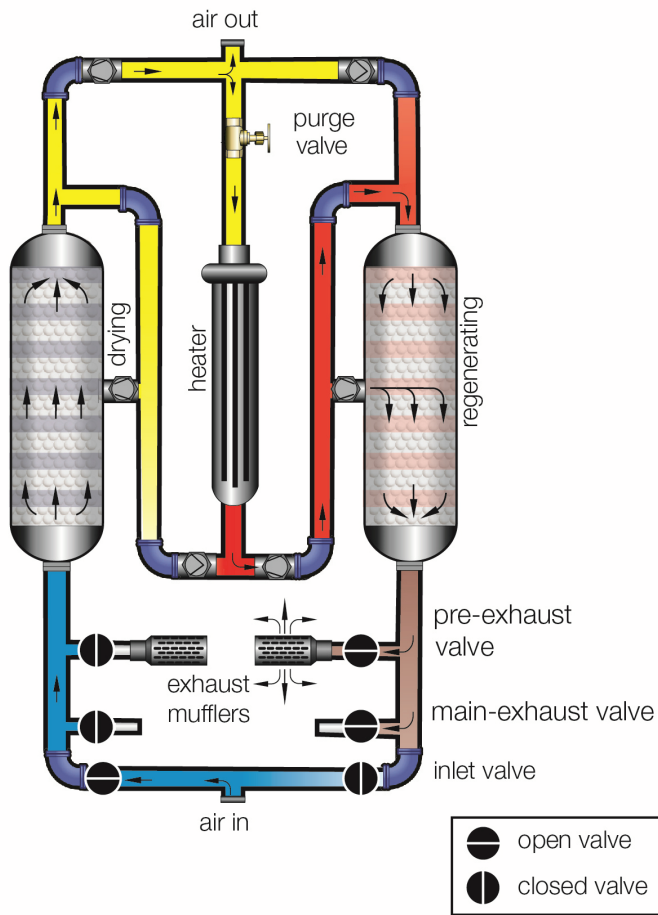

TWP Desiccant Dryer Operation

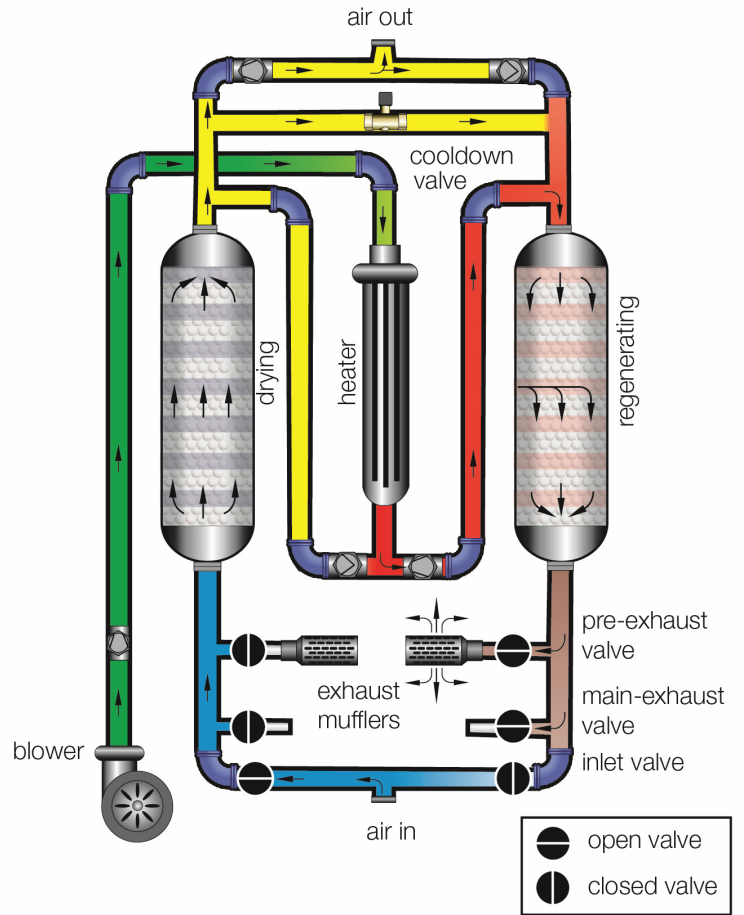

TWB Desiccant Dryer Operation

### FLOW SCHEMATIC MODELS TWP201-301

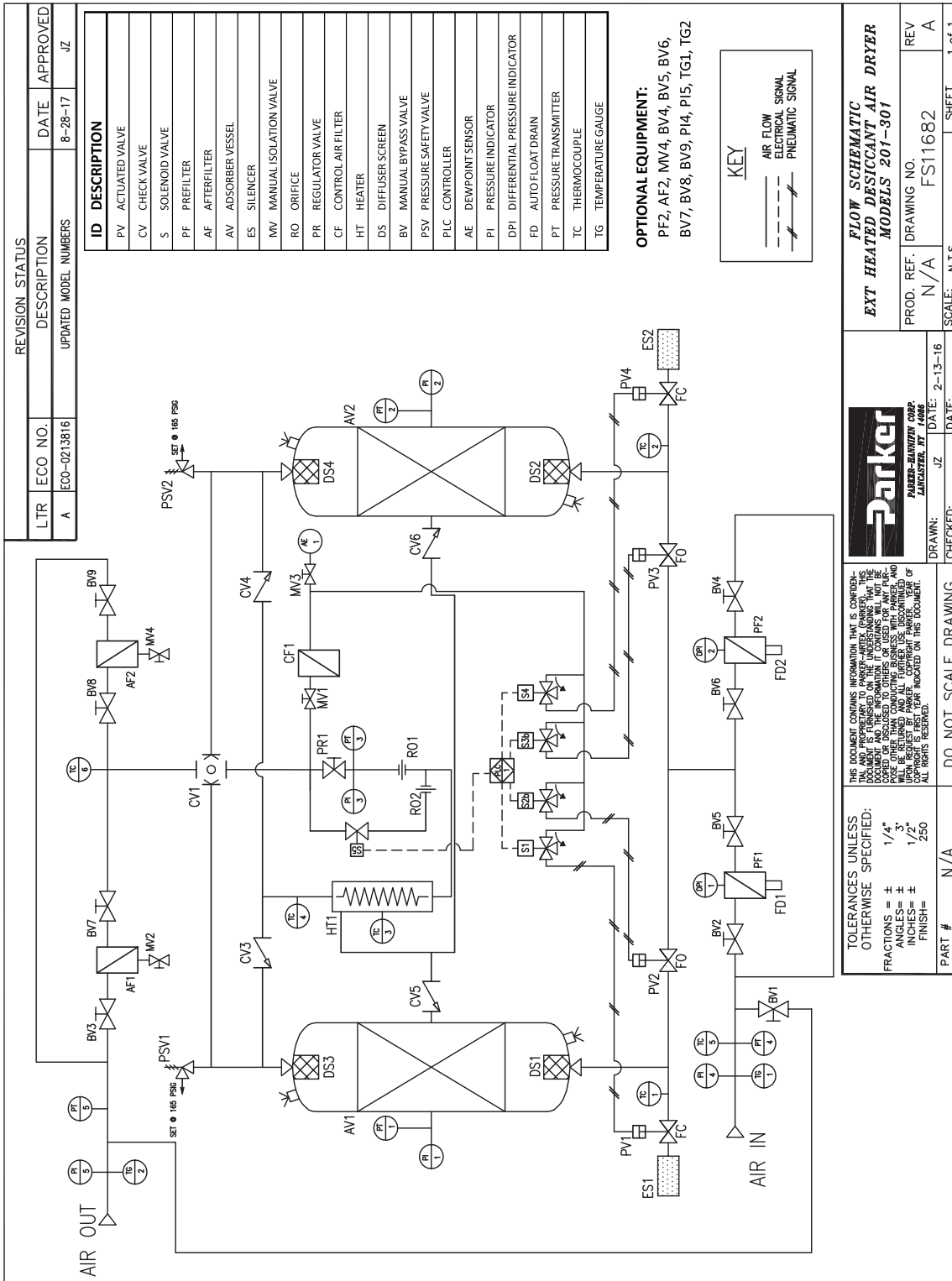

FLOW SCHEMATIC MODELS TWP401-801

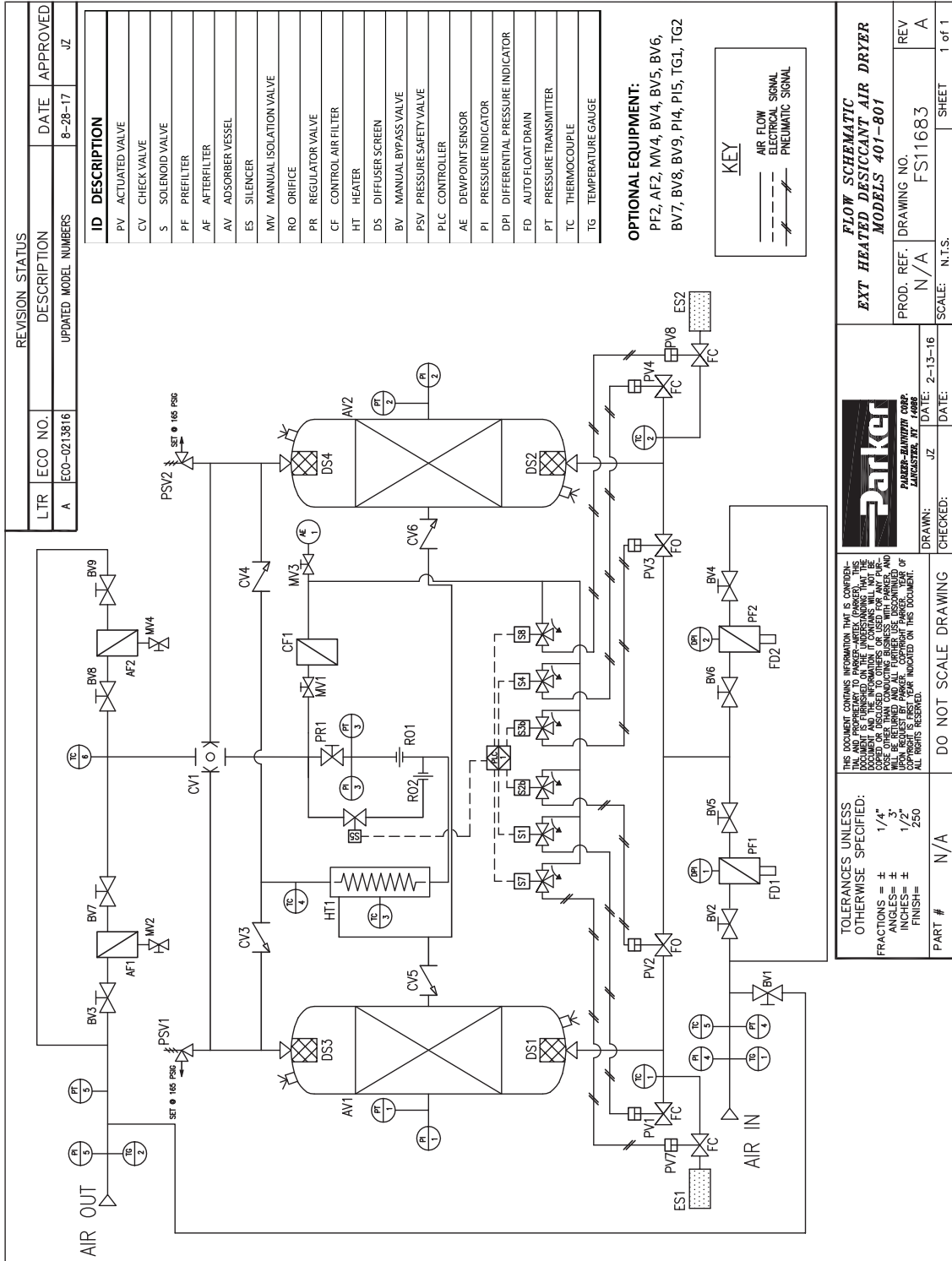

	<b>FLOW SCHEMATIC</b> <b>EXT HEATED DESICCANT AIR DRYER</b> <b>MODELS 401-801</b>
	PROD. REF. DRAWING NO. FS11683 REV. A
DRAWN: JZ CHECKED: N/A DATE: 2-13-16	SCALE: N.T.S. SHEET: 1 of 1

  

**THIS DOCUMENT CONTAINS INFORMATION THAT IS CONFIDENTIAL AND PROPRIETARY TO PARKER-AIRTEK (PARKER). THIS DOCUMENT AND THE INFORMATION IT CONTAINS WILL NOT BE COPIED, REPRODUCED, OR DISCLOSED TO OTHERS WITHOUT THE WRITTEN PERMISSION OF PARKER-AIRTEK. ALL RIGHTS ARE RESERVED. COPYRIGHT © 2016 PARKER-AIRTEK. ALL RIGHTS RESERVED.**

TOLERANCES UNLESS OTHERWISE SPECIFIED: FRACTIONS = ± 1/4" ANGLES = ± 3° INCHES = ± 1/32" FINISH = Z50	DO NOT SCALE DRAWING PART # N/A
---	------------------------------------



FLOW SCHEMATIC MODELS TWP1001-1201

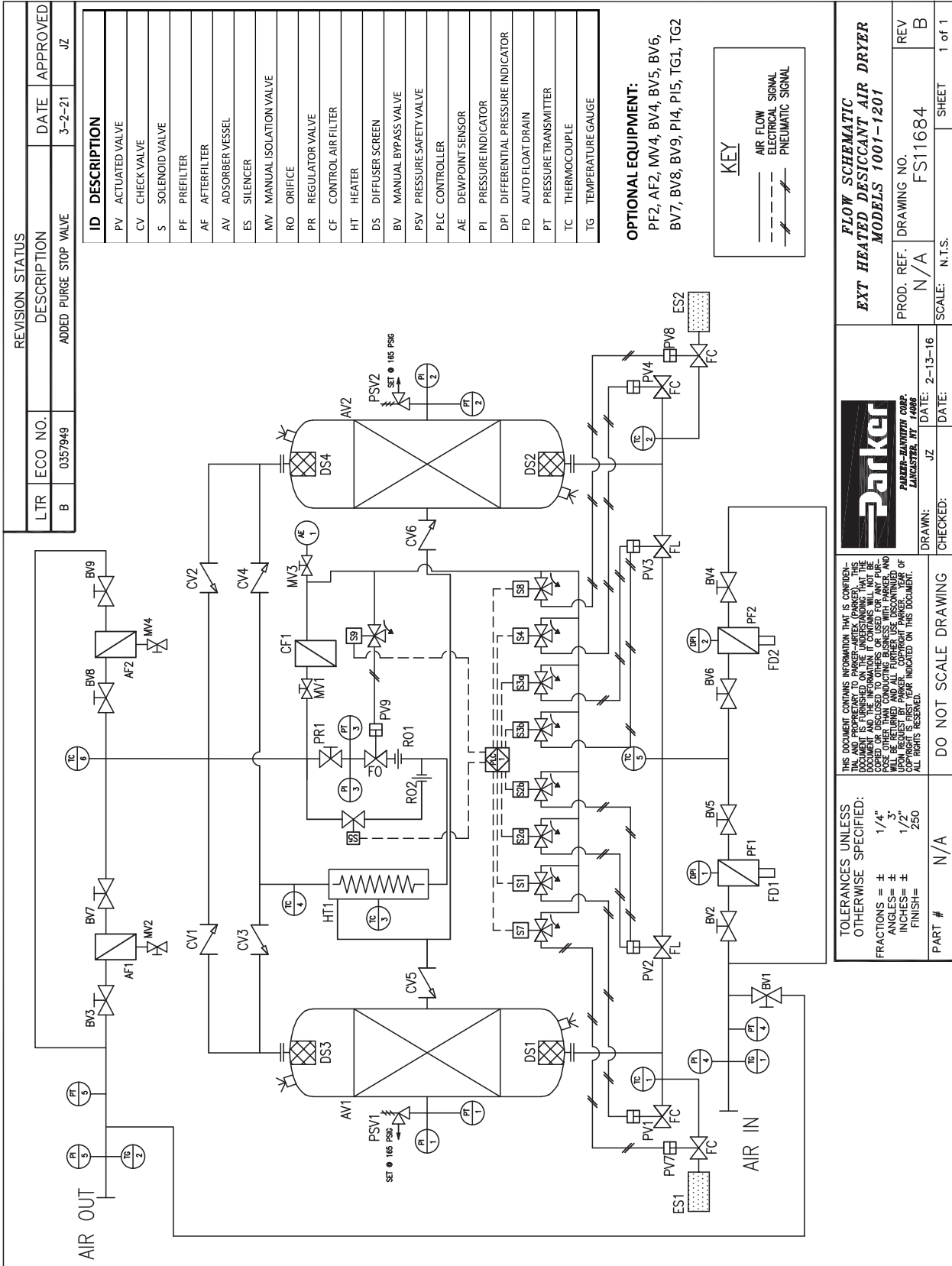

**FLOW SCHEMATIC**  
**EXT HEATED DESICCANT AIR DRYER**  
**MODELS 1001-1201**

PROD. REF. N/A  
 DRAWING NO. FS11684  
 REV. B

SCALE: N.T.S. SHEET 1 of 1

**Parker**  
 PARKER-HANFORD CORP.  
 LANCASTER, NY 14086

DATE: 2-13-16  
 DRAWN: JZ  
 CHECKED: N.T.S.

THIS DOCUMENT CONTAINS INFORMATION THAT IS CONFIDENTIAL AND PROPRIETARY TO PARKER-HANFORD CORP. (PARKER). THIS DOCUMENT IS FURNISHED ON THE UNDERSTANDING THAT THE INFORMATION CONTAINED HEREIN IS NOT TO BE REPRODUCED, COPIED OR DISCLOSED TO OTHERS OR USED FOR ANY PURPOSE OTHER THAN CONDUCTING BUSINESS WITH PARKER, AND UPON REQUEST BY PARKER, COPYRIGHT PARKER, ALL RIGHTS RESERVED.

TOLERANCES UNLESS OTHERWISE SPECIFIED:  
 FRACTIONS = ± 1/4"  
 ANGLES = ± 1°  
 FINISH = 250

PART # N/A  
 DO NOT SCALE DRAWING

FLOW SCHEMATIC MODELS TWP1501-7501

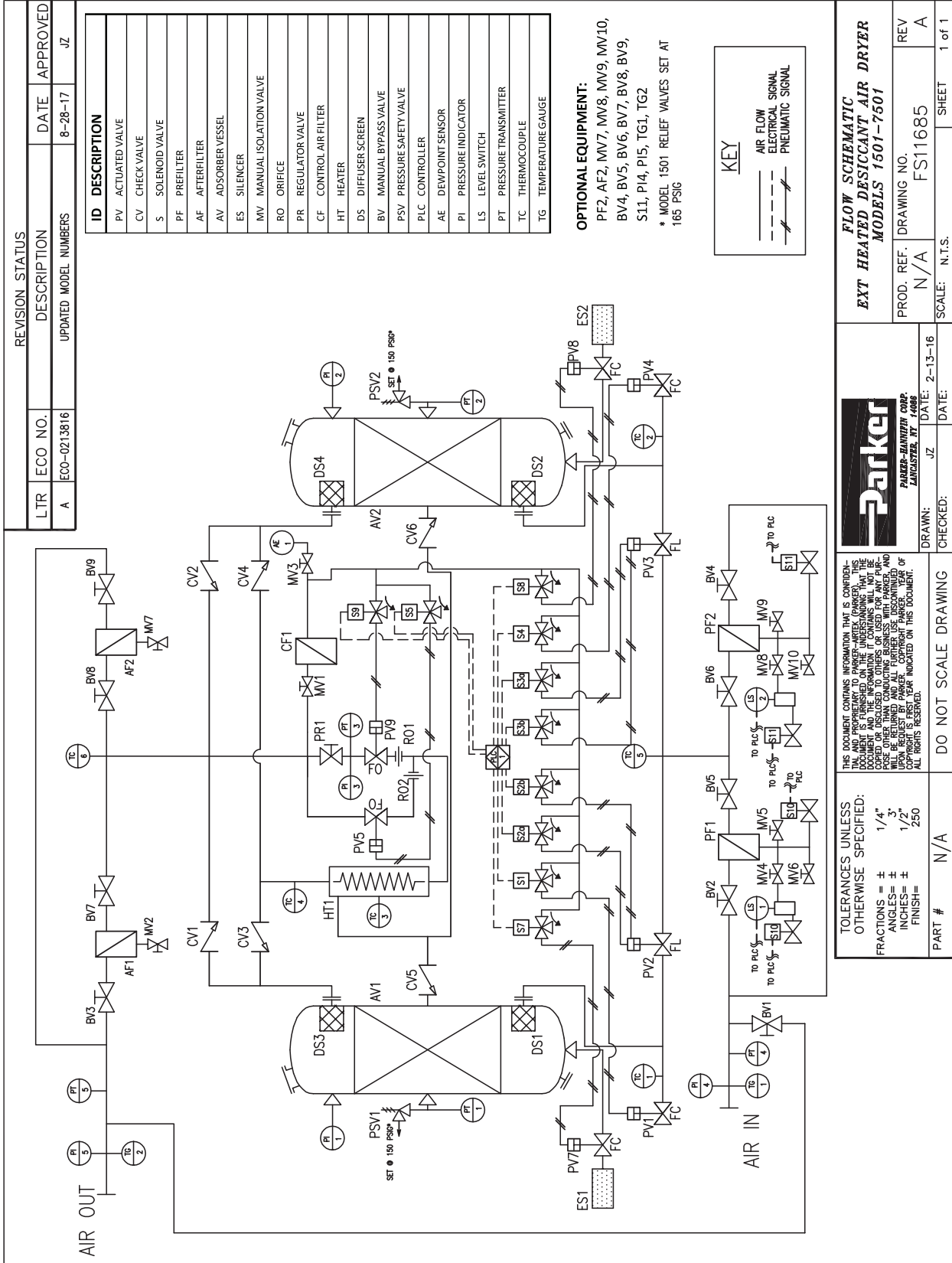

**FLOW SCHEMATIC**  
**EXT HEATED DESICCANT AIR DRYER**  
**MODELS 1501-7501**

PROD. REF. N/A  
 DRAWING NO. FS11685  
 REV. A

SCALE: N.T.S.  
 SHEET 1 of 1

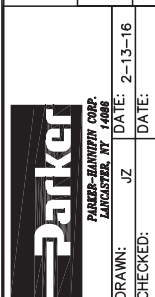

THIS DOCUMENT CONTAINS INFORMATION THAT IS CONFIDENTIAL AND PROPRIETARY TO PARKER-HANNIFIN CORP. THE INFORMATION CONTAINED HEREIN IS NOT TO BE DISCLOSED TO ANY OTHER PARTY WITHOUT THE WRITTEN PERMISSION OF PARKER-HANNIFIN CORP. ANY UNAUTHORIZED USE, REPRODUCTION, OR DISSEMINATION OF THIS INFORMATION IS STRICTLY PROHIBITED. ALL RIGHTS RESERVED.

**TOLERANCES UNLESS OTHERWISE SPECIFIED:**

FRACTIONS = ± 1/4"  
 ANGLES = ± 3°  
 INCHES = ± 1/2"  
 FINISH = 250

PART # N/A  
 DO NOT SCALE DRAWING  
 DATE: 2-13-16  
 DRAWN: JZ  
 CHECKED: N.T.S.

FLOW SCHEMATIC MODELS TWB201-801

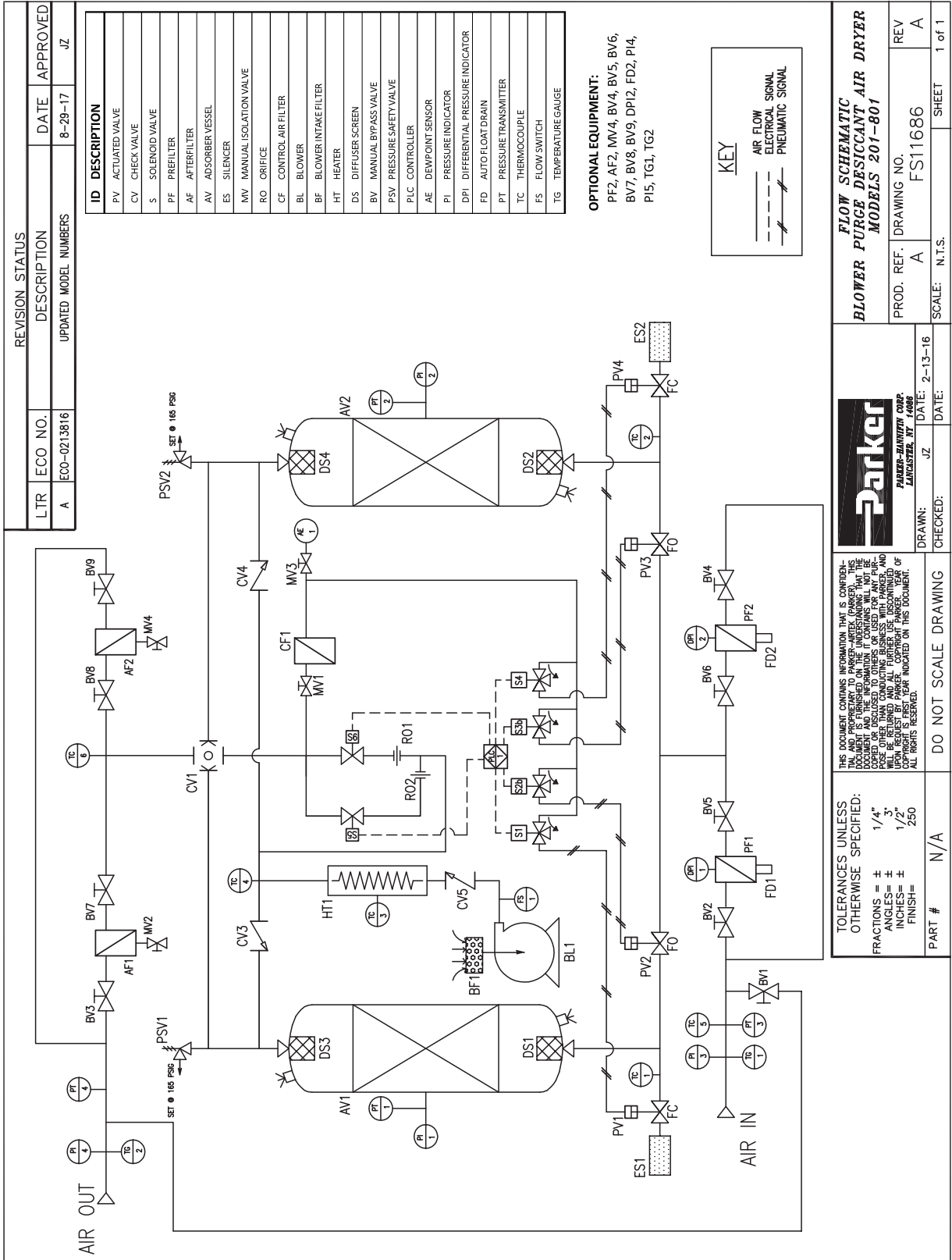

**Parker**  
 PARKER-HANNIFIN CORP.  
 HANOVER, NY 14456

THIS DOCUMENT CONTAINS INFORMATION THAT IS CONFIDENTIAL TO PARKER-HANNIFIN CORP. IT IS TO BE KEPT SECRET AND NOT DISCLOSED TO ANY OTHER PERSONS OR COMPANIES WITHOUT THE WRITTEN PERMISSION OF PARKER-HANNIFIN CORP. THE INFORMATION CONTAINED HEREIN IS THE PROPERTY OF PARKER-HANNIFIN CORP. AND IS NOT TO BE REPRODUCED OR TRANSMITTED IN ANY FORM OR BY ANY MEANS, ELECTRONIC OR MECHANICAL, INCLUDING PHOTOCOPYING, RECORDING, OR BY ANY INFORMATION STORAGE AND RETRIEVAL SYSTEM. ALL RIGHTS RESERVED.

DRAWN: JZ	DATE: 2-13-16	CHECKED: N.T.S.	SHEET 1 of 1
DO NOT SCALE DRAWING		SCALE: N.T.S.	

**TOLERANCES UNLESS OTHERWISE SPECIFIED:**  
 FRACTIONS = ± 1/4"  
 ANGLES = ± 3°  
 INCHES = ± 1/2"  
 FINISH = Z50

**PART #** N/A

**FLOW SCHEMATIC  
 BLOWER PURGE DESICCANT AIR DRYER  
 MODELS 201-801**

PROD. REF. A    DRAWING NO. FS11686    REV. A

FLOW SCHEMATIC MODELS TWB1001-1201

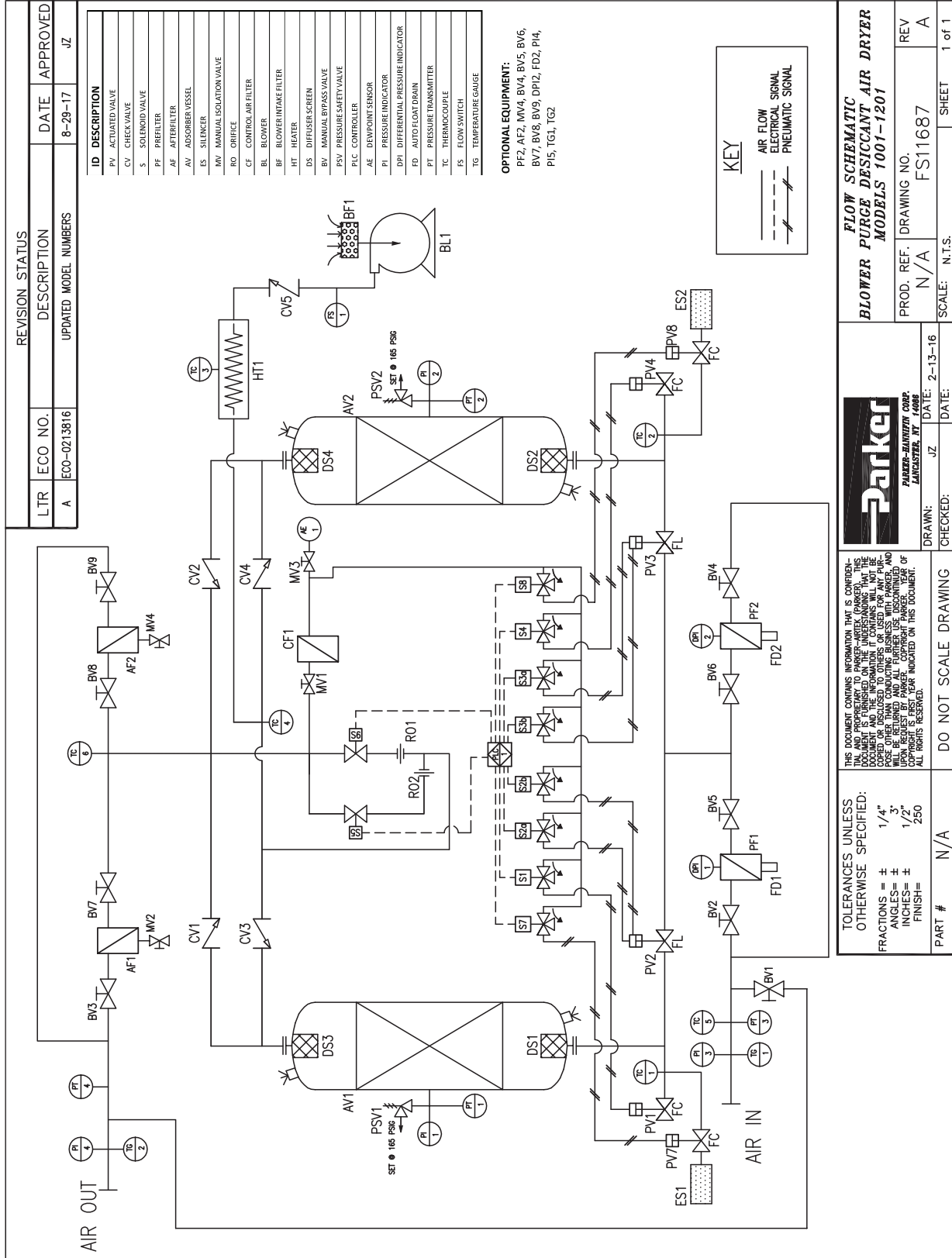

**FLOW SCHEMATIC  
 BLOWER PURGE DESICCANT AIR DRYER  
 MODELS 1001-1201**

PROD. REF. DRAWING NO. REV  
 N/A FS11687 A

SCALE: N.T.S. SHEET 1 of 1

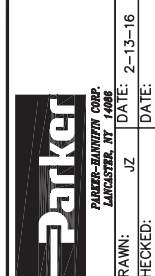

THIS DOCUMENT CONTAINS INFORMATION THAT IS CONFIDENTIAL AND THE INFORMATION CONTAINED HEREIN IS NOT TO BE DISCLOSED TO ANY OTHER PERSON OR ENTITY WITHOUT THE WRITTEN PERMISSION OF PARKER HANNIFIN CORPORATION. ALL RIGHTS RESERVED.

DATE: 2-13-16

DRAWN: JZ CHECKED: DATE:

TOLERANCES UNLESS OTHERWISE SPECIFIED:  
 FRACTIONS = ± 1/4"  
 DECIMALS = ± 0.005"  
 FINISH = 250

PART # N/A

DO NOT SCALE DRAWING



FLOW SCHEMATIC MODELS TWB1501-7501

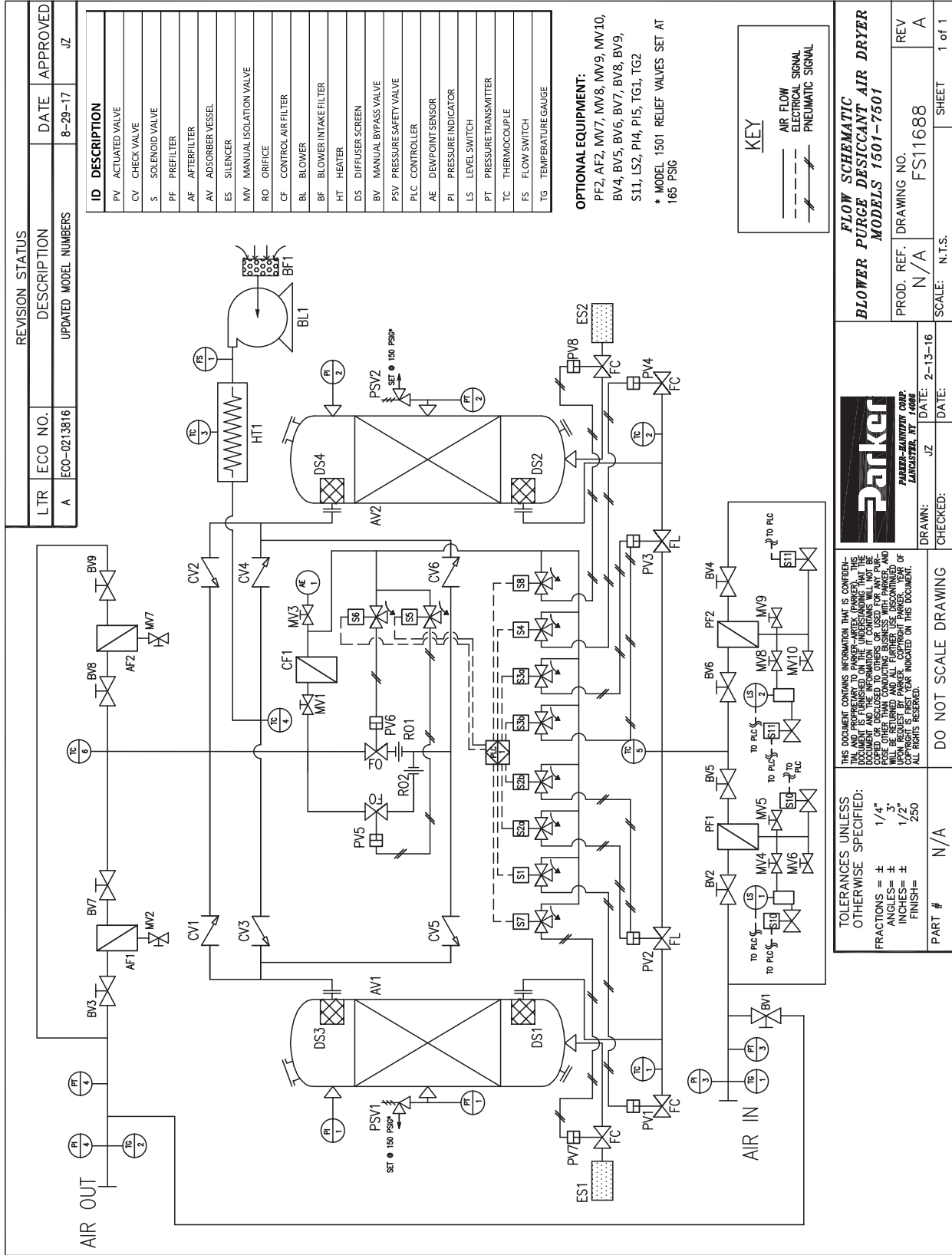

**Flow Schematic**  
**Blower Purge Desiccant Air Dryer**  
**Models 1501-7501**

PROD. REF. N/A      DRAWING NO. FS11688      REV. A

SCALE: N.T.S.      SHEET 1 of 1

**Parker**  
 PARKER-HANNIFIN CORP.  
 LANCASTER, NY 14086

DRAWN: JZ      DATE: 2-13-16

CHECKED:      DATE:

THIS DOCUMENT CONTAINS INFORMATION THAT IS CONFIDENTIAL AND PROPRIETARY TO PARKER-HANNIFIN CORP. THE DOCUMENT IS FURNISHED ON THE UNDERSTANDING THAT THE INFORMATION IS NOT TO BE REPRODUCED, COPIED, OR DISCLOSED TO OTHERS OR USED FOR ANY PURPOSE OTHER THAN CONDUCTING BUSINESS WITH PARKER-HANNIFIN CORP. WITHOUT THE WRITTEN PERMISSION OF PARKER-HANNIFIN CORP. ALL RIGHTS RESERVED.

**TOLERANCES UNLESS OTHERWISE SPECIFIED:**

FRACTIONS = ± 1/4"

DECIMALS = ± 0.005"

ANGLES = ± 1/2°

FINISH = 250

PART # N/A

DO NOT SCALE DRAWING



TWP WIRING DIAGRAM STANDARD CONTROLLER

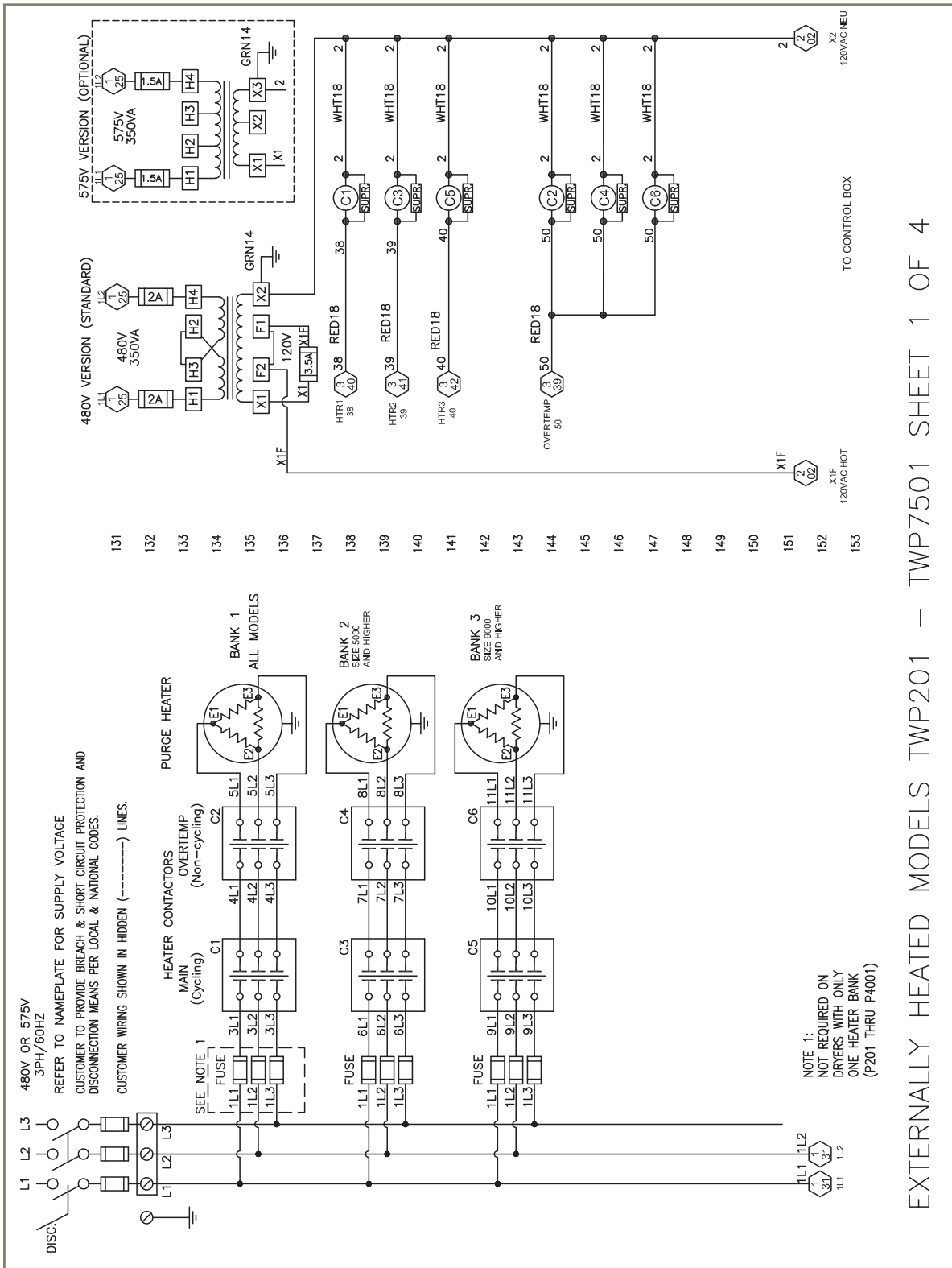

EXTERNALLY HEATED MODELS TWP201 – TWP7501 SHEET 1 OF 4

TWP WIRING DIAGRAM STANDARD CONTROLLER

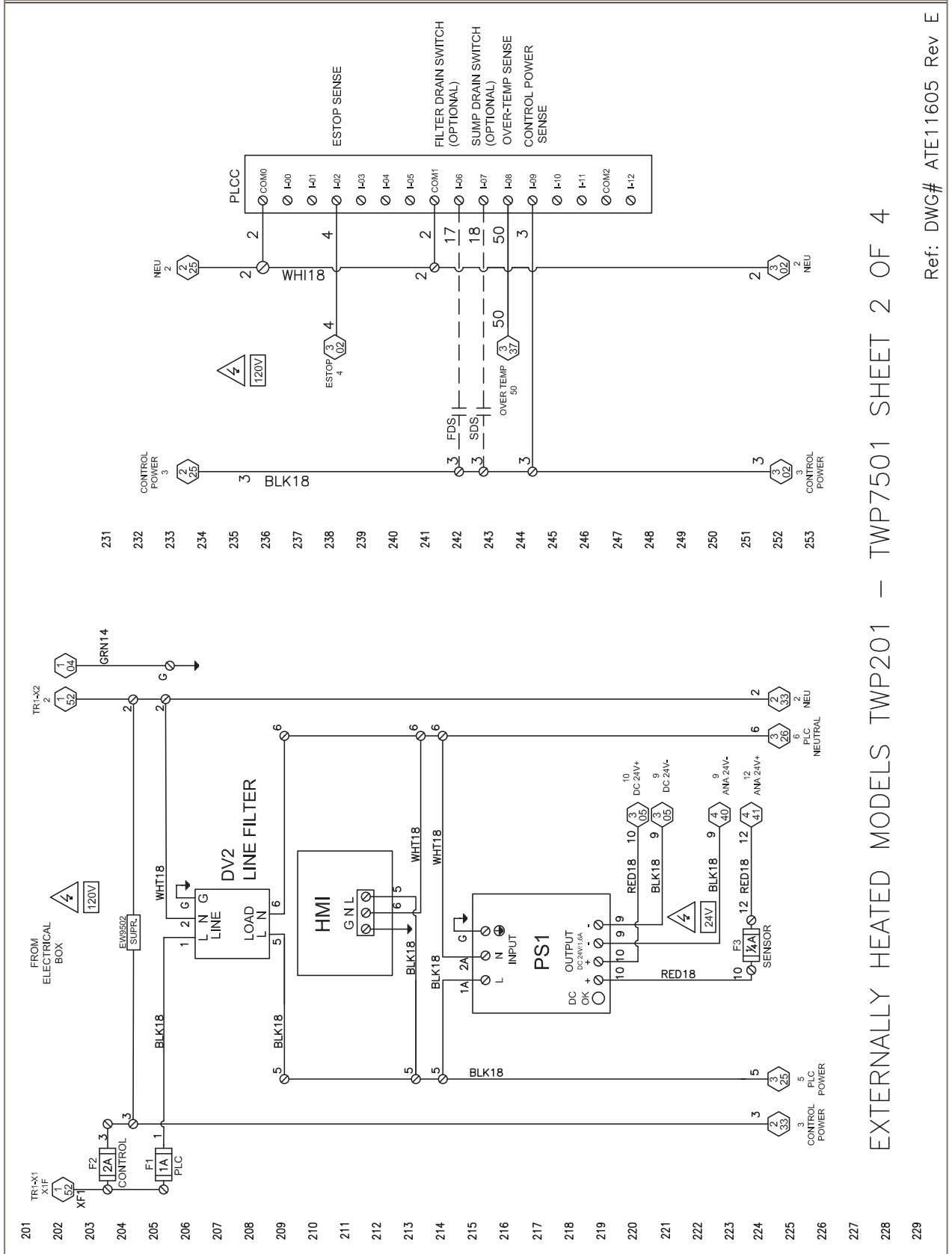

EXTERNALLY HEATED MODELS TWP201 – TWP7501 SHEET 2 OF 4

Ref: DWG# ATE11605 Rev E

TWP WIRING DIAGRAM STANDARD CONTROLLER

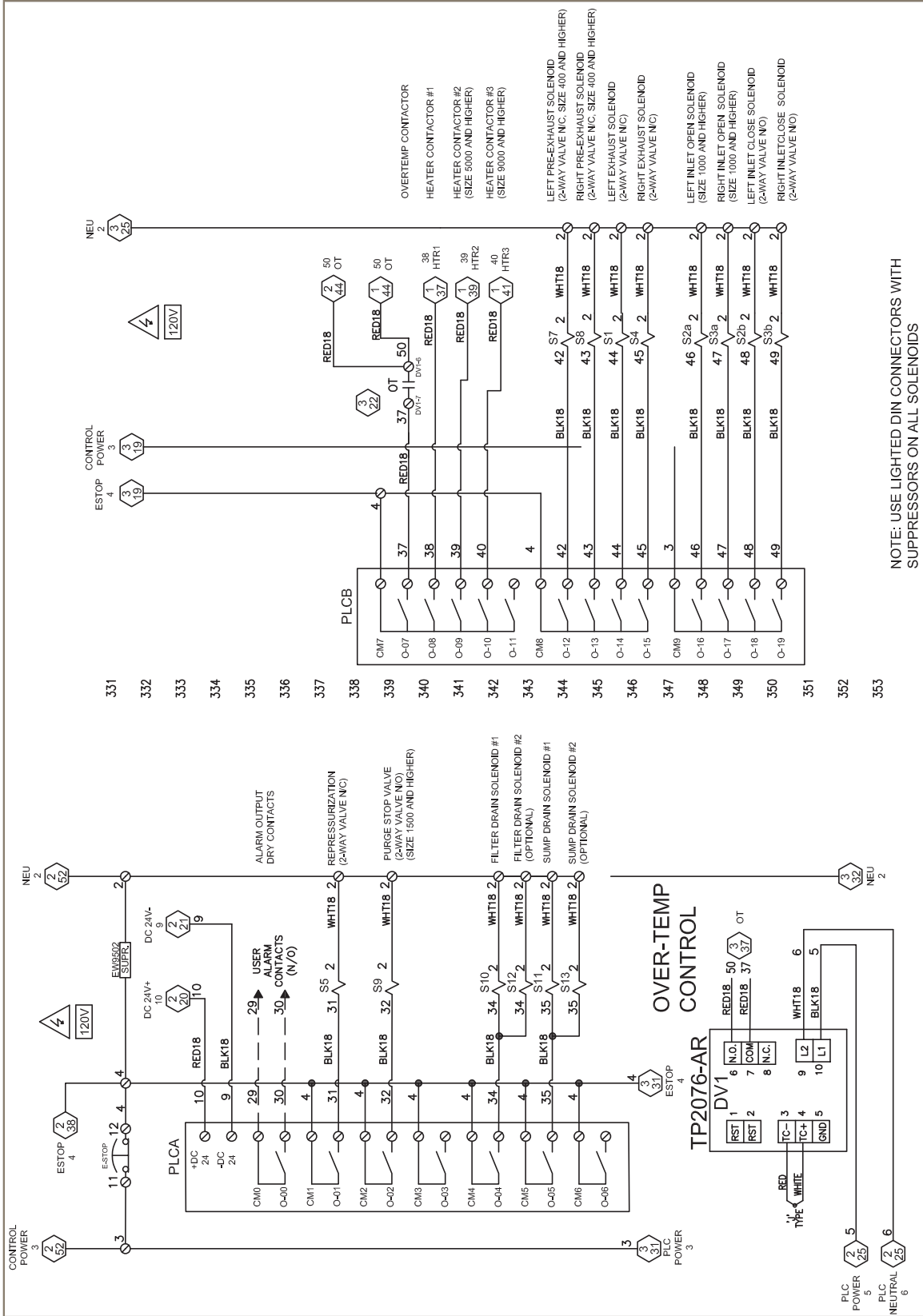

NOTE: USE LIGHTED DIN CONNECTORS WITH SUPPRESSORS ON ALL SOLENOIDS

TWP WIRING DIAGRAM STANDARD CONTROLLER

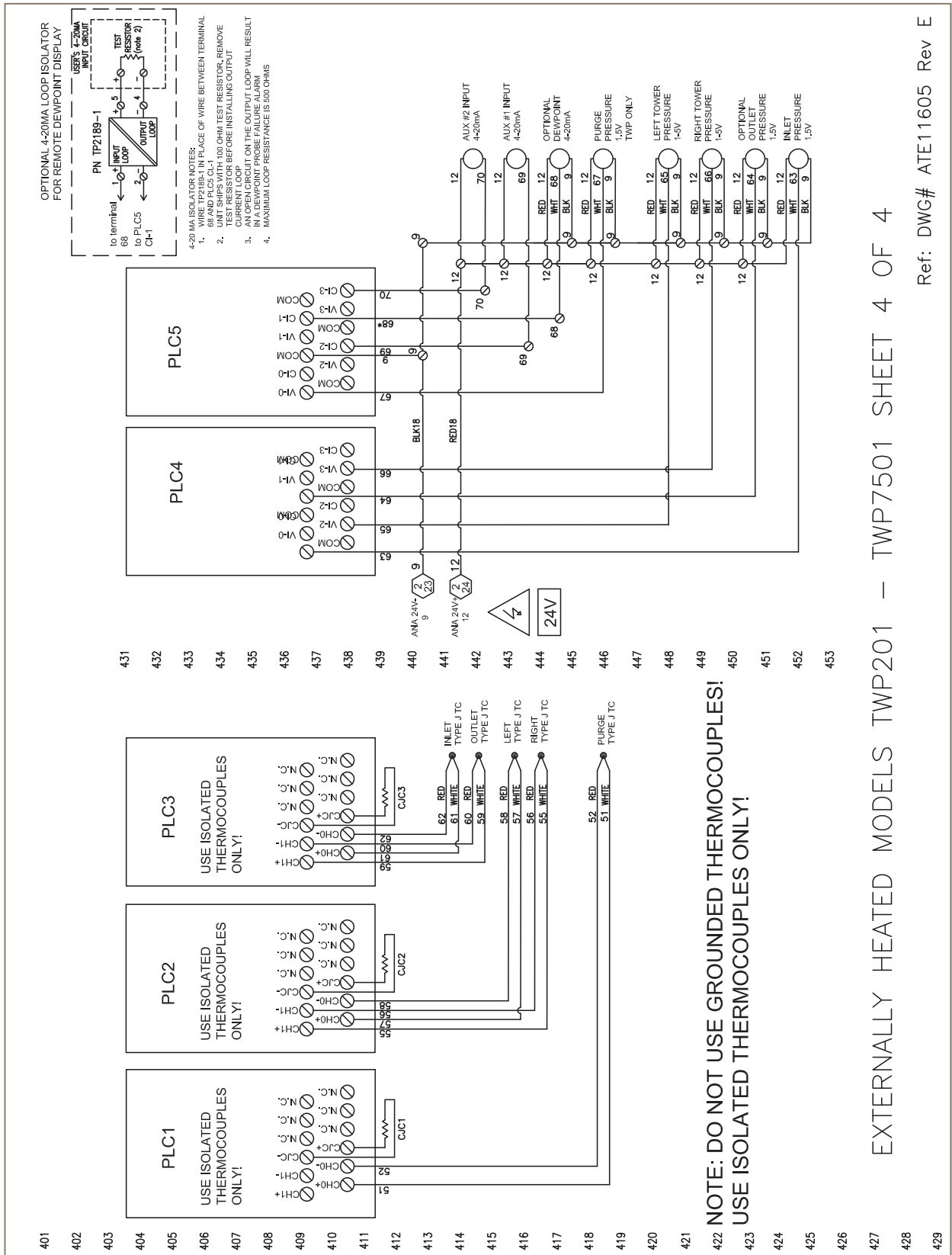

- 4-20 MA ISOLATOR NOTES:
1. WIRE TP2189-1 IN PLACE OF WIRE BETWEEN TERMINAL 68 AND PLC5 CH-1
  2. UNIT SHIPS WITH 100 OHM TEST RESISTOR, REMOVE TEST RESISTOR BEFORE INSTALLING OUTPUT CIRCUIT
  3. AN OPEN CIRCUIT ON THE OUTPUT LOOP WILL RESULT IN A DEWPOINT PROBE FAILURE ALARM
  4. MAXIMUM LOOP RESISTANCE IS 500 OHMS

**NOTE: DO NOT USE GROUNDED THERMOCOUPLES!  
USE ISOLATED THERMOCOUPLES ONLY!**

TWB WIRING DIAGRAM STANDARD CONTROLLER

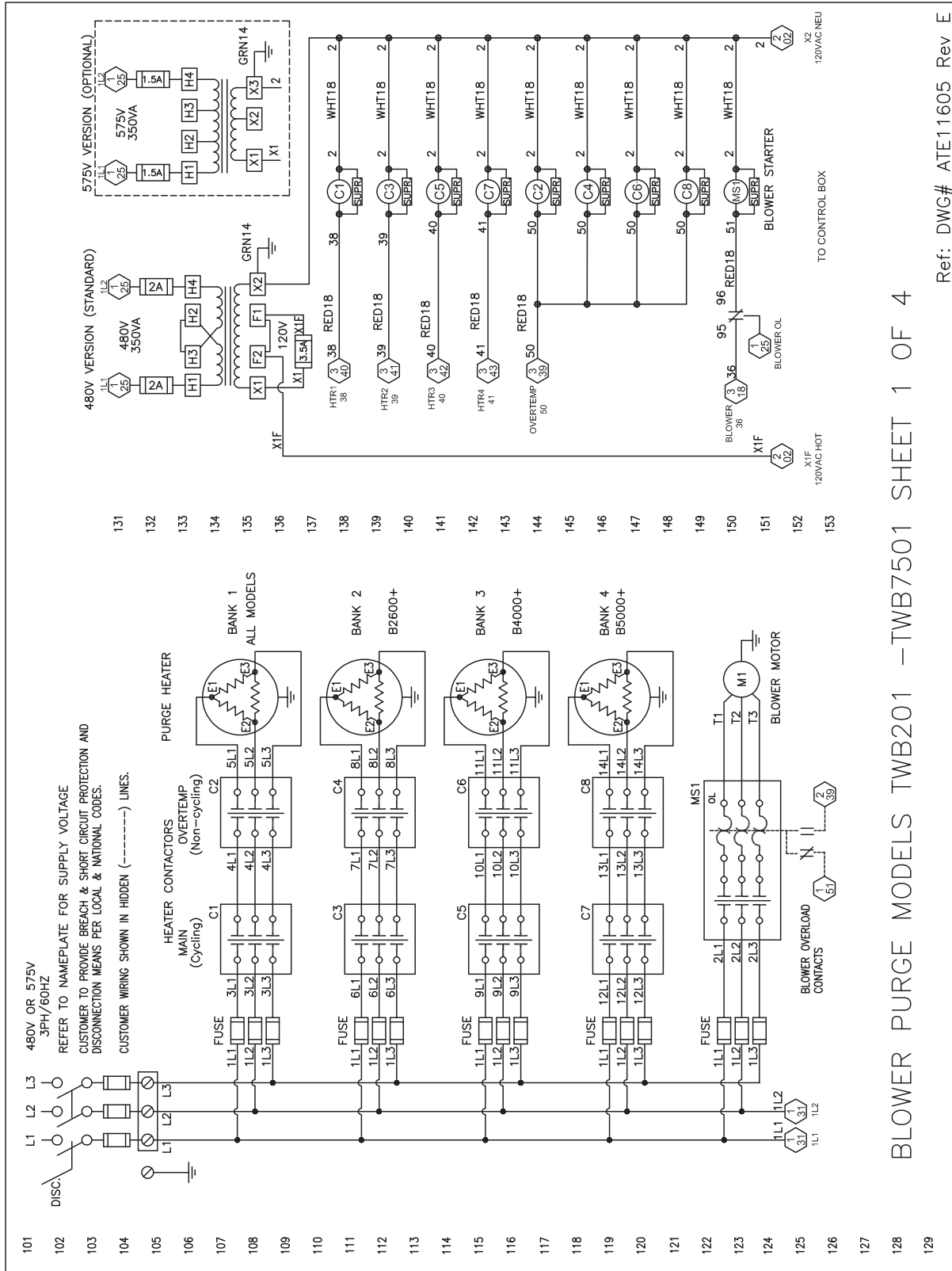

BLOWER PURGE MODELS TWB201 – TWB7501 SHEET 1 OF 4

Ref: DWG# ATE11605 Rev E

TWB WIRING DIAGRAM STANDARD CONTROLLER

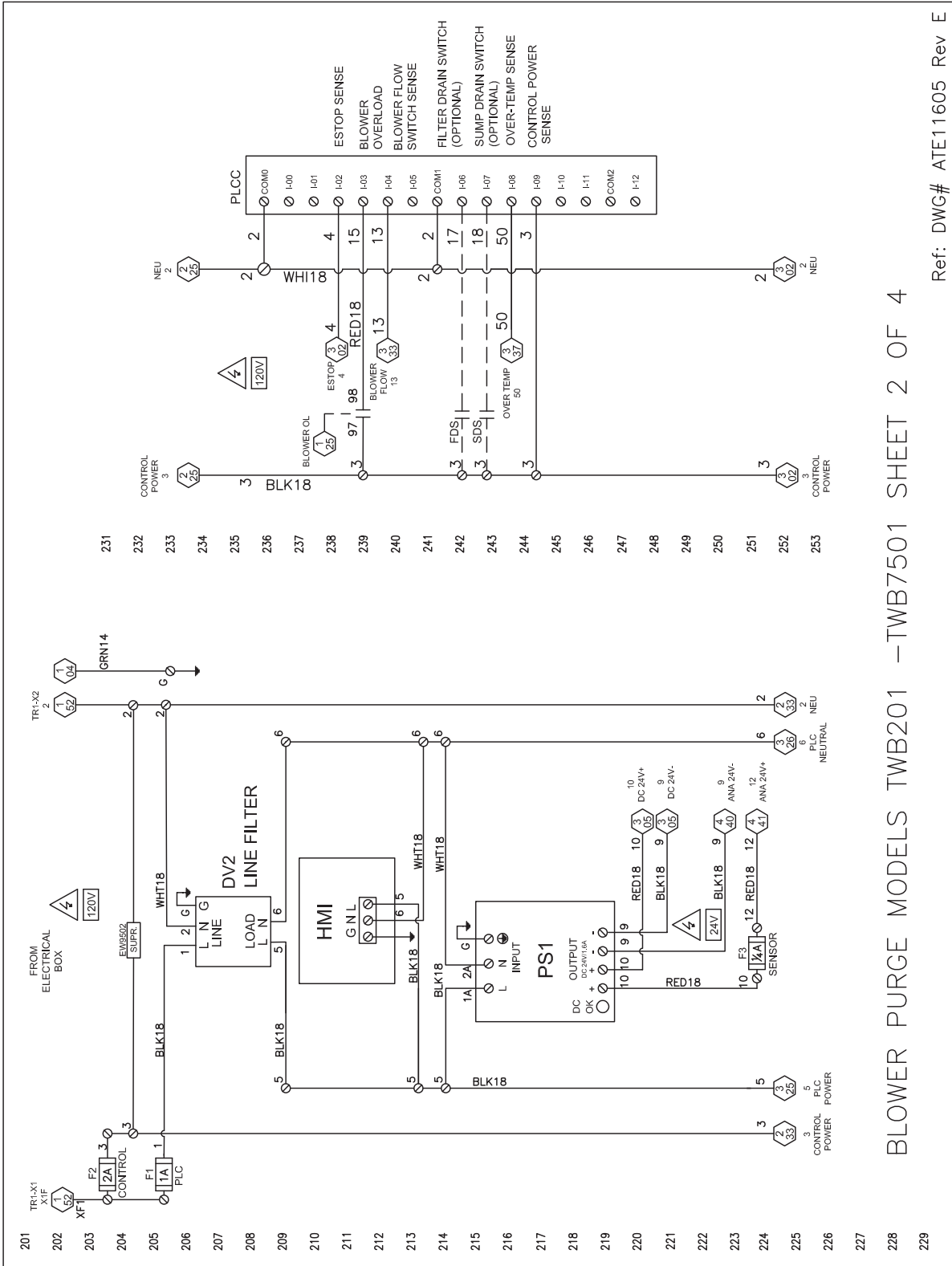

BLOWER PURGE MODELS TWB201 – TWB7501 SHEET 2 OF 4

Ref: DWC# ATE11605 Rev E

TWB WIRING DIAGRAM STANDARD CONTROLLER

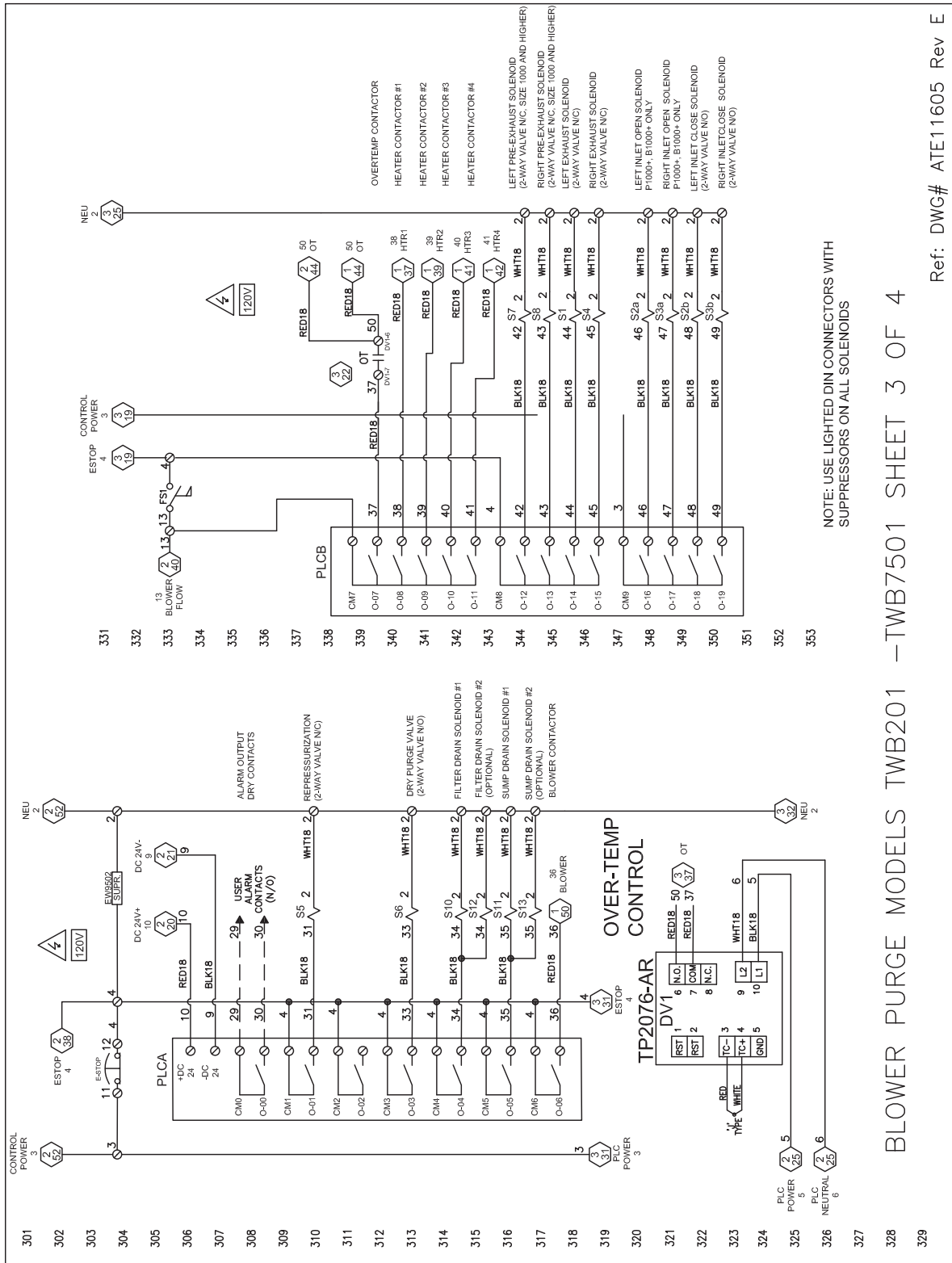

NOTE: USE LIGHTED DIN CONNECTORS WITH SUPPRESSORS ON ALL SOLENOIDS

BLOWER PURGE MODELS TWB201 – TWB7501 SHEET 3 OF 4

Ref: DWG# ATE11605 Rev E



TWB WIRING DIAGRAM STANDARD CONTROLLER

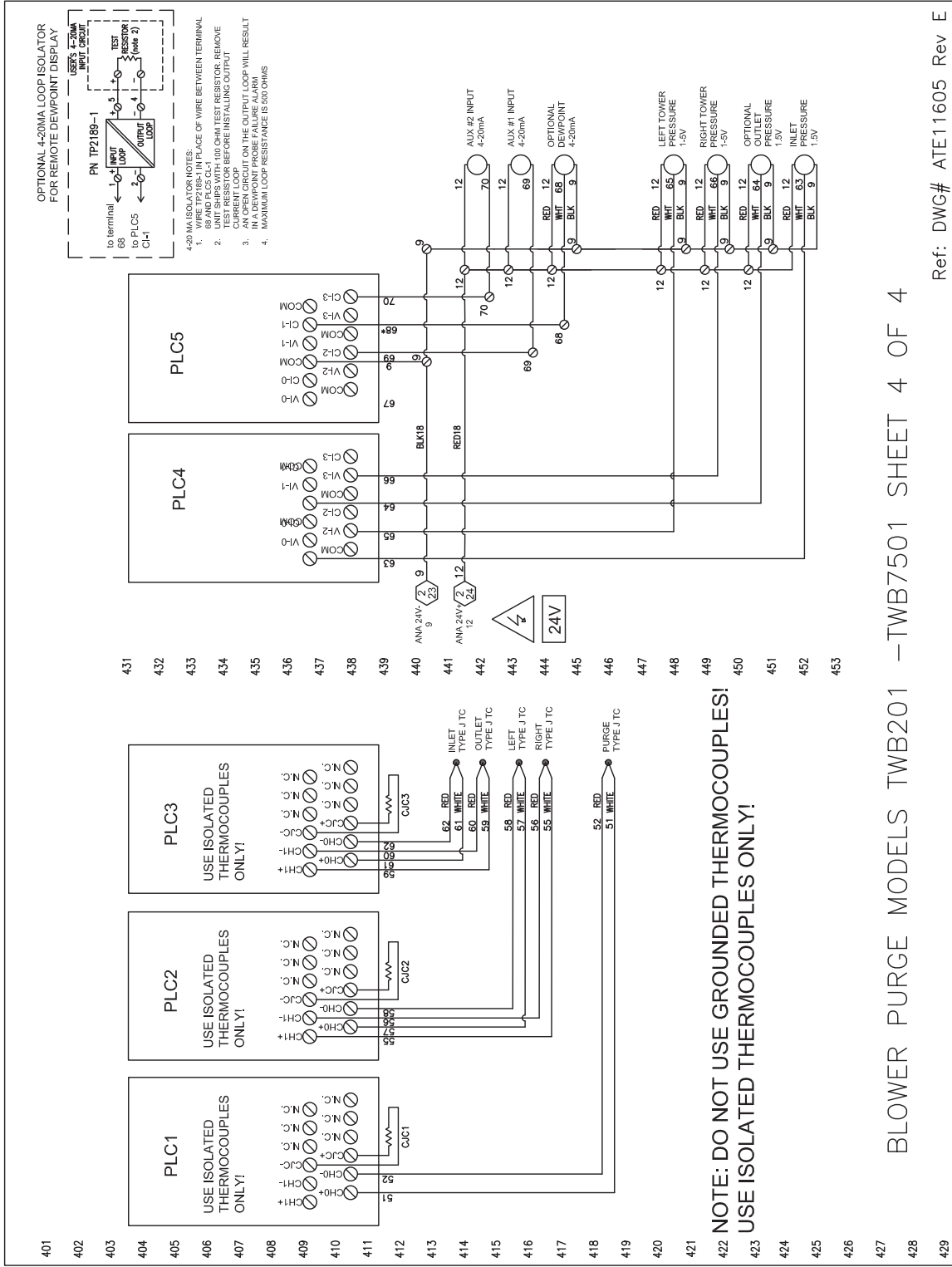

Ref: DWG# ATE11605 Rev E

BLOWER PURGE MODELS TWB201 – TWB7501 SHEET 4 OF 4



PANEL LAYOUT STANDARD CONTROLLER

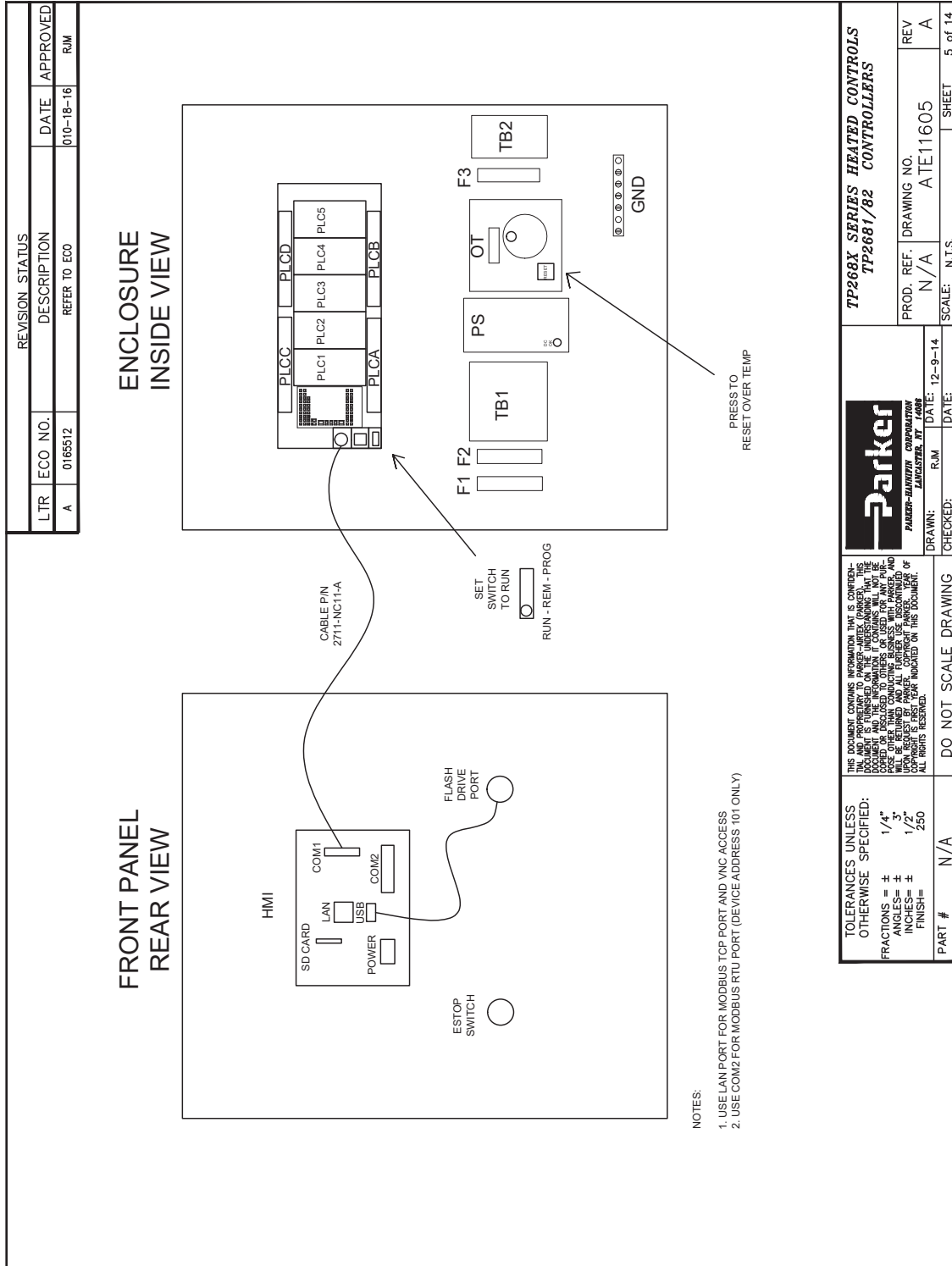

**TP268X SERIES HEATED CONTROLS  
TP2681/82 CONTROLLERS**

PROD. REF. DRAWING NO. N/A ATE11605  
REV A

SCALE: N.T.S. SHEET 5 of 14

**Parker**  
PARKER-HANVON CORPORATION  
LANCASTER, NY 14608

DRAWN: RJM DATE: 12-9-14  
CHECKED: DATE:

THIS DOCUMENT CONTAINS INFORMATION THAT IS CONFIDENTIAL AND THE INFORMATION CONTAINED HEREIN IS THE PROPERTY OF PARKER. IT IS TO BE KEPT IN STRICTLY CONFIDENTIAL AND NOT BE DISCLOSED TO ANY OTHER PERSON OR ENTITY WITHOUT THE WRITTEN PERMISSION OF PARKER. ANY UNAUTHORIZED DISCLOSURE OR USE OF THIS INFORMATION SHALL BE SUBJECT TO LEGAL ACTION. ALL RIGHTS RESERVED.

TOLERANCES UNLESS OTHERWISE SPECIFIED:

FRACTIONS = ± 1/4"  
 ANGLES = ± 3°  
 INCHES = ± 1/2"  
 FINISH = 250

PART # N/A DO NOT SCALE DRAWING

## START UP

Verify all piping and electrical connections are secure. Do not power the dryer at this time.

Start the compressor and pressurize the air system, bypassing the dryer.

**Slowly** pressurize the dryer by opening the inlet isolation valve. It is important to allow the dryer to slowly pressurize to prevent fluidization of the desiccant bed. Rapid pressurization can also cause damage to the vessel internal screens and filter elements.

The dryer must be started without the mufflers installed. This will expedite removal of excess desiccant dust and prevent premature clogging of the mufflers.



**CAUTION: USE EAR AND EYE PROTECTION WHEN OPERATING THE DRYER WITHOUT MUFFLERS. EXCESSIVE NOISE WILL BE CREATED. DUST AND PARTICLES FROM THE SURROUNDING AREA MAY BECOME AIRBORNE. OPERATION WITHOUT MUFFLERS EXCEEDS OSHA LIMITS.**

Open the control air ball valve.

Push in the emergency stop button.

Power up the dryer. Check rotation of blower by pushing in contactor manually. If opposite of the flow direction arrow, switch the two leads.

Pull the emergency button out.

**Start in Heatless** - Touch the START IN HEATLESS OPERATION button from the controller's SERVICE screen to start the dryer. The dryer will initially ensure that vessels are pressurized, then will begin by blowing down one of the vessels while placing the opposite 'drying' vessel online. If you do not want the dryer to begin cycling automatically, close the control air ball valve. This will prevent the inlet and exhaust valves from switching. In this situation, a bad blowdown alarm will occur which must be reset from the control panel after re-opening the control air ball valve.

The dryer can be run in the heatless mode for two or three cycles to quickly remove desiccant dust caused by shipping or filling the unit. This also serves to verify that the vessels are switching normally, and to allow resolving any issues with system pressure before applying heat the regeneration process.

**Switch to Heated** - When you are ready to switch the dryer to HEATED regeneration operation, simply touch the START IN HEATED OPERATION button from the controller's Service screen. The dryer will immediately repressurize, then switch towers and start HEATED regeneration on the opposite vessel.

Install the exhaust mufflers on the dryer.

**Check Purge Pressure** - For TWP dryers, verify the purge pressure setting is correct for the operating conditions. The purge pressure setting must be set to the factory advised setting while using the dewpoint demand feature. The purge pressure must be set while in the Heated Regeneration State. Do not adjust the purge pressure when operating in the heatless backup timing configuration. Heater will shutoff if purge pressure is 10 psig or less. Heater will not turn on until purge pressure rises to 15 psig or greater.

**Heating** - Verify that the heater contactor(s) pull in and the purge air temperature value on the controller screen begins to rise. If the dryer is blower type, then the blower will also be running at this time.

**Over-Temp** - There is a redundant over-temperature module inside the control cabinet that is preset at the factory to 650°F. This module monitors a thermocouple for purposes of independently sensing an over-temperature condition. In addition, there is an over-temp setting, also preset the factory to 650°F, accessed from the ADVANCED SETTINGS screen on the controller. This setting is associated with the purge temperature sensor.

It is not uncommon for the heater to shut down due to an over-temperature condition during initial startup of the dryer. If this should happen, verify that the purge pressure setting agrees with the suggested setting and that there is no backpressure in the regenerating tower (as would occur if a muffler was clogged or a check valve was not functioning properly). If there is no sign of back pressure, then increase the overtemp adjustment on the over-temp module, and the over-temp setting in the Advanced Setting screen by 50°F increments and reset the alarm. Repeat until optimal overtemp settings are achieved. Consult factory if the dryer continues to shut down on over-temp at a setting of 750°F or above.

Slowly open the dryer outlet isolation valve. Close the bypass valve. If applicable, tighten manway cover bolts. It is common for the manway gasket to undergo additional compression on startup.

## TIMING CONFIGURATION

The controller is designed for externally heated, blower purge and heatless backup cycle operation. The timing configuration is pre-set at the factory for the specific dryer model. The default timing settings for each configuration are listed below.

<b>Externally Heated Cycle: 8 hours</b>	<b>Blower Purge Cycle: 8 hours</b>	<b>Heatless Backup Cycle: 14 min</b>
Drying: 4 hours per tower.	Drying: 4 hours per tower.	Drying: 7 min per tower.
Heating: 2 hours 30 min per tower.	Heating: 2 hours 30 min per tower.	Purging: 6 min per tower.
Cooling/Purging: 1 hour 27 min per tower.	Cooling: 2 min per tower.	Repressurization: 1 min per.
Repressurization: 3 min per tower.	Purging: 85 min per tower.	
	Repressurization: 3 min per tower.	

The heating time is the maximum per tower per cycle. To save energy, the system is designed to end the heating cycle and advance to cooling once the offline tower is fully regenerated. For blower purge models, the user may disable the 2% cooling feature in order to prevent using dry purge air during regeneration. The cooling time will then default to 25 min per tower per cycle.

Externally heated and blower purge dryers are both equipped with a heatless backup cycle as a standard feature. This configuration may be selected by the user to use dry purge air for regeneration in place of heated air. This operating cycle consumes 15-18% dry purge air and has a much shorter cycle time than the heated cycle.

Heatless backup can be used when there is an issue with the heated regeneration function of the dryer, but dry air is still needed. The heatless backup cycle will allow the dryer to continue to produce dry air until a time when the dryer can be shut down for service and maintenance. Heatless backup can also be used to more quickly purge a new or oversaturated dryer. Once the dryer begins to achieve consistent dewpoint, the dryer can be switched back to HEATED REGENERATION.

The dewpoint demand function is an energy savings feature that extends the drying cycle as long as the user defined dewpoint requirements are met. The offline desiccant vessel completes its regeneration process as normal and then waits in an idle state until the dewpoint degrade to the setpoint before switching over. By extending the drying cycle, less purge air is consumed over a period of time. The Dewpoint Demand feature must be set to ENABLED and the dewpoint sensor must be installed in the DEWPOINT SETTINGS screen.

## MANUAL STEPPING

This feature is used to assist in maintenance and troubleshooting of the dryer. Touching the STEP button at the main screen will advance thru the regeneration states. This allows the user to skip ahead to desired stages of the regeneration process more quickly. Using this feature may yield worse than desired dewpoints until the dryer is allowed to cycle uninterrupted. For safety, when attempting to switch out of repressurization or blowdown, the dryer will wait until the pressures in the tanks are at a safe level before proceeding to the next state.

**CAUTION: Never step through the cooling state. Doing so may result in extreme temperatures being released downstream. Only switch out of cooling if you are certain there is no possibility of releasing dangerous heat downstream.**

## CONTROLLER DISPLAY & OPERATION

The dryer’s controller is an Allen-Bradley® PLC coupled with a proprietary color, touch panel HMI. The controller is factory programmed with the proper timing configurations for the dryer model. The controller features user configurable drain settings, timing configuration, dewpoint demand cycles, system pressure and temperature monitoring, system alarms with user configurable settings and alarm log, and a manual stepping feature for maintenance. Additionally, there is reference information for troubleshooting dryer operation and alarms.

The standard controller display is accessible at the front of the dryer without opening the enclosure. If the enclosure must be opened, always remember to close and secure the enclosure door when not using!

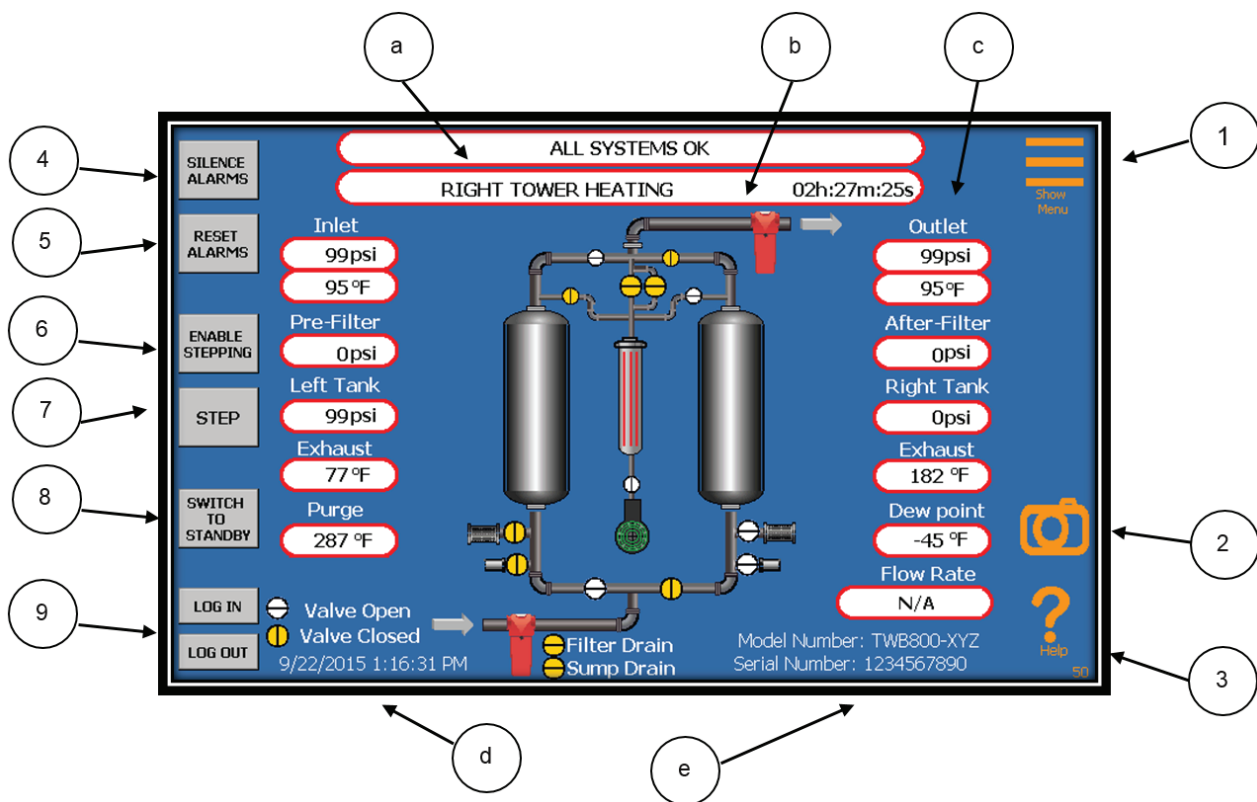

### Main Screen User Controls

1. **Menu Icon** – Press to display the menu icons on the sides of the display.
2. **Snapshot Icon** – Press to save a snapshot of any screen to a flash drive.
3. **Help Icon** – Press to display online help screens where available.
4. **Silence Button** – Press to silence the alarm screen and turn off the alarm relay.
5. **Alarm Reset Button** – Press to reset all alarms and restart regeneration.
6. **Enable Step Button** – Press to enable the manual step function.
7. **Step Button** – Press to step to the next regeneration state – Use with caution.
8. **Standby Button** – Press to place the dryer in standby and to restart the dryer.
9. **Log In / Log Out Buttons** – Press to log in and log out as required  
Supervisor default password is SUP (all caps).

These passwords may be changed, however, if the password is lost, the display must be completely reprogrammed in order to reset, resulting in a potential service call!

### Main Screen Information Display

#### a. **Status Message Line** –

Cycles thru one or more of the following, as well as, any active alarms.

**PRESS START KEY WHEN READY**

Displayed only before the dryer is started for the first time.

**DRYER NOT CONFIGURED!**

Displayed only before the dryer is configured for the first time.

**ALL SYSTEMS OK**

Default message – No alarms. Dryer is running in normal operation.

**ALARM SHUTDOWN**

Regeneration has shut down.

To restart, Press the Alarm Reset button.

**LOW CONTROL AIR - REGENERATION SUSPENDED**

Inlet air pressure is too low to provide sufficient control air for the dryer.

Regeneration is paused until air pressure returns.

**MANUAL STEPPING ACTIVE**

The Step button is active – Use with Care!

**GOING TO STANDBY**

Standby button has been touched and the dryer is waiting to go to standby

If heating, the dryer will cool for 2 minutes before going to Standby.

**DRYER IN STANDBY - REGENERATION SUSPENDED**

Dryer is in standby and will wait indefinitely until the Standby button has been touched again.

**SWITCHING TO HEATLESS**

The Switch To Heatless button has been touched from the Service Screen.  
The dryer will immediately switch to cooling and completely cool the tower before switching to Heatless.

**SWITCHING TO HEATED**

The Switch To Heated button has been touched from the Service Screen.  
The dryer will immediately switch to Heated once the towers have repressurized.

**RUNNING IN HEATLESS BACKUP**

The dryer is running in Heatless Regeneration Mode.

**DRYER IN POWER SAVER STATE**

The Dewpoint is below the dewpoint demand set point at the end of the standard drying time.

Dryer will wait until dewpoint rises above the set point before switching towers.

**EXTENDED PURGING ACTIVE (Blower Models Only)**

The 2% Cooling Setting is enabled in the Advanced Setting screen.

The dewpoint is below the dewpoint demand set point at the end of the standard drying time.

The regenerating tower will continue to regenerate for the amount of time specified in the Extended Drying Time setting (Typically 60 minutes), or until the dewpoint rises above the dewpoint demand set point.

Not applicable if Dewpoint Demand is not installed and enabled.

Refer to the Alarms Section for a complete list of alarm messages which are also displayed on this line.

**a. State Message Line –**

Displays the current regeneration state and the amount of time remaining in that state.

**DRYER PARKED**

The dryer has not yet been started. Once the dryer is started, it cannot be placed into PARKED state without re-programming the PLC.

**LEFT TOWER BLOWING DOWN / RIGHT TOWER BLOWING DOWN**

Regenerating tower is waiting to depressurize before purging.

**LEFT TOWER HEATING / RIGHT TOWER HEATING**

Heated purge air is regenerating the tower before purging.

**LEFT TOWER BLOWER COOLING / RIGHT TOWER BLOWER COOLING  
(Blower Models Only).**

Blower is cooling down the heater tube before switching to Cooling Regeneration.

**BLOWER REGENERATION MODELS ONLY.**

**LEFT TOWER COOLING / RIGHT TOWER COOLING**

Cool air is cooling down the tower.

If the dryer uses a blower and the Use 2% Purge Cooling setting is enabled, additional purging also takes place during this state.

LEFT TOWER EXTENDED PURGE / RIGHT TOWER EXTENDED PURGE

(Blower Models Only)

If the dryer uses a blower and the Use 2% Purge Cooling setting is enabled, and the dewpoint is above the dewpoint demand setting, then the tower will continue to regenerate using dry air until it times out, or the dewpoint rises above the demand set point.

LEFT TOWER REPRESSURIZING / RIGHT TOWER REPRESSURIZING

Regenerating tower is waiting to pressurize before switching towers.

RIGHT DRYING - TIME REMAINING / LEFT DRYING - TIME REMAINING

Dryer still has time remaining on the drying tower and is waiting for the time to expire before switching towers.

SWITCHING TOWERS

Towers are switching.

REGENERATING LEFT TOWER / REGENERATING RIGHT TOWER (Heatless Mode)

Dryer is in heatless backup mode and regenerating the tower.

**b. Sensor Values**

- Inlet Pressure and Temperature
- Outlet Pressure
- Pre-Filter Pressure
- After-Filter Pressure
- Outlet Temperature
- Left and Right Tank Pressures
- Left and Right Exhaust Temperatures
- Purge Temperature
- Purge Pressure (Dry Purge models only)
- Dewpoint (Optional)
- Flow Meter (Optional)

**c. Time**

**d. Model and Serial Number**

**e. Active Dryer Graphic**

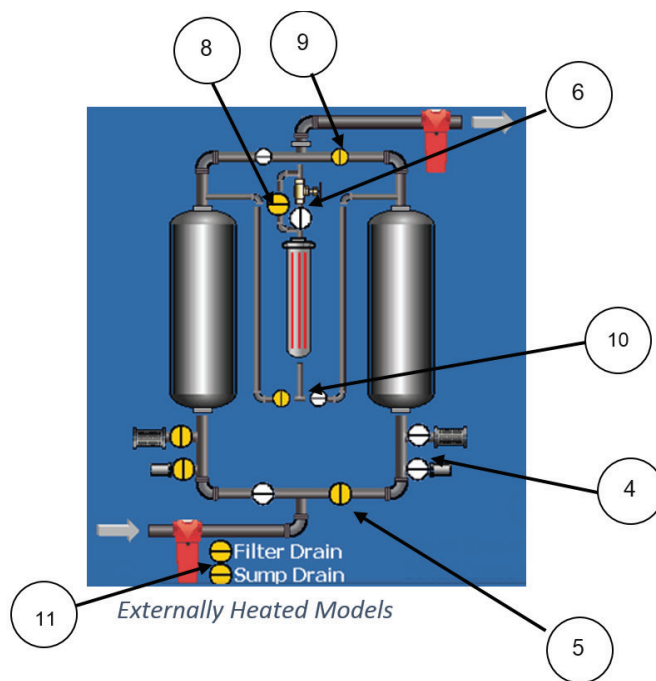
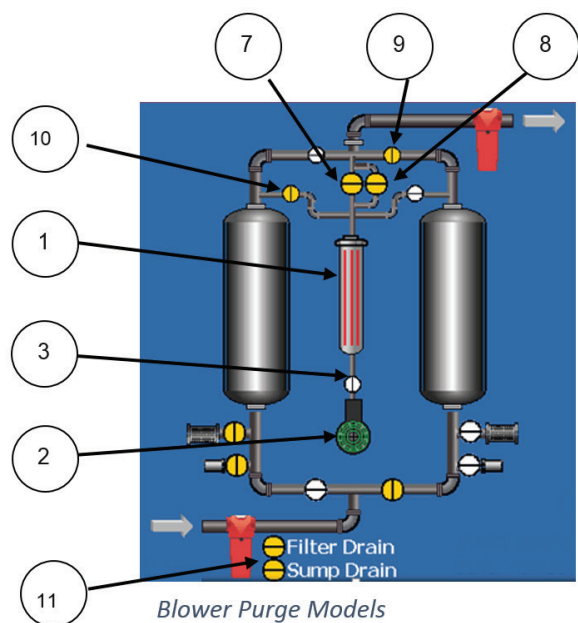

- |   |  |
|---|--|
| <p><b>1. Heater Tube</b><br/>Red when heater is active</p> <p><b>2. Blower (Blower Purge Models Only)</b><br/>Green when blower is running,<br/>Red during Blower related alarms</p> <p><b>3. Blower Flow Switch (Blower Purge Models Only)</b><br/>Yellow – indicates lack of flow across flow switch<br/>White – indicates lack of flow across flow switch<br/>Yellow – indicates flow across blower flow switch</p> <p><b>4. Exhaust Valves (2 or 4 depending on pre-exhaust)</b><br/>White – indicates valve(s) are open<br/>Yellow – indicates valves are closed</p> <p><b>5. Inlet Valves (2)</b><br/>White – indicates valve(s) are open<br/>Yellow – indicates valves are closed</p> <p><b>6. Purge Stop Valve (Externally Heated Models Only)</b><br/>White – indicates valve(s) are open<br/>Yellow – indicates valves are closed</p> | <p><b>7. 2% Purge Valve (Blower Purge Models Only)</b><br/>White – indicates valve(s) are open<br/>Yellow – indicates valves are closed</p> <p><b>8. Repressurization Valve</b><br/>White – indicates valve(s) are open<br/>Yellow – indicates valves are closed</p> <p><b>9. Outlet Check Valves (2)</b><br/>White – no air is flowing thru valve<br/>Yellow – air is flowing thru valve</p> <p><b>10. Purge Check Valves (2)</b><br/>White – no air is flowing thru valve<br/>Yellow – air is flowing thru valve</p> <p><b>11. Drain Valves (Optional)</b></p> |
|---|--|



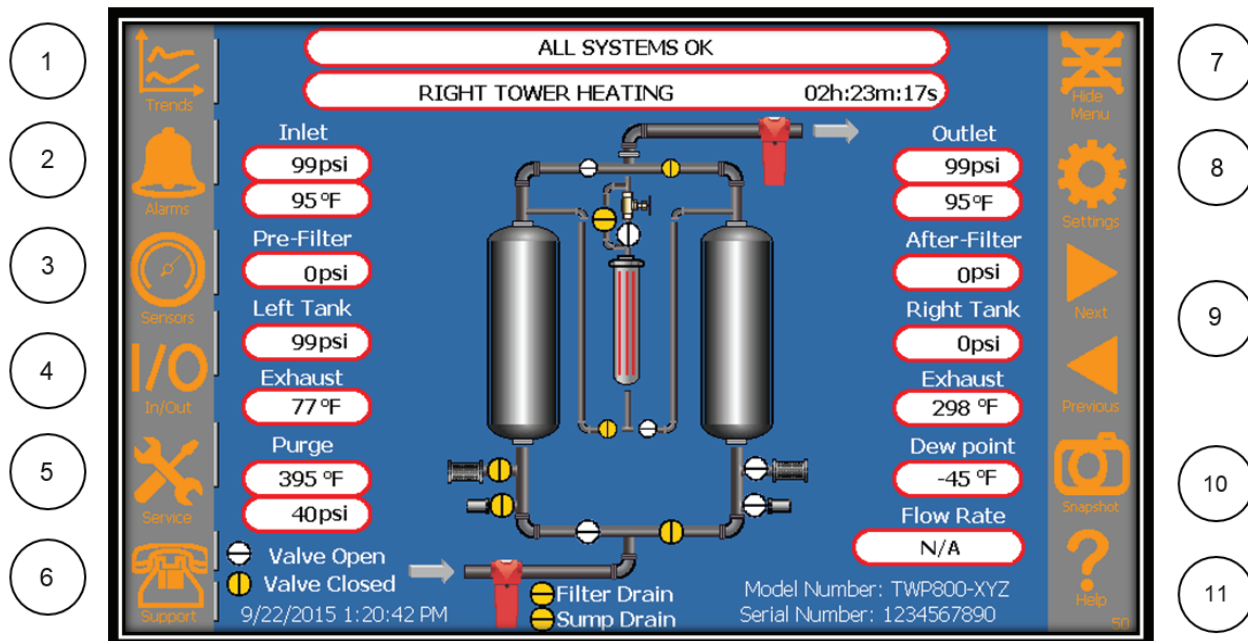

1. Trending Icon – Press to access trending screens.
2. Alarms Icon – Press to access Active alarms and alarm history.
3. Sensors Icon – Press to display real-time sensor values, including user sensors.
4. I/O Screens Icon – Press to display the states of the PLC Inputs and Outputs.
5. Service Icons – Press for access to user and service related functions.
6. Support Icon – Press for access to dryer and support information.
7. Hide Menu Icon – Press to hide the menu icons.
8. Settings Icon – press to step thru the setting screens.
9. Page Left and Page Right Icons – Press to step thru the setting screens.
10. Snapshot Icon – Press to save a snapshot of any screen to the flash drive.
11. Help Icon – Press to display online help screens.

Main Screen User Controls

Available for dryers which include a Dewpoint Demand sensor.

Drain Settings

Optional - Only applicable for dryers which control the drains using the PLC.

User Sensor Settings

There are two 4-20 mA inputs on the PLC for the user.  
 If Sensor #1 is selected as a Flow Meter input, its value is displayed on the Main Display  
 Sensors #1 and #2 real-time values are accessed from the Sensor Screen.

Alarm Settings

## Advance Settings

**Advanced Settings**

Control Air On Pressure  psi

Purge Temperature  °F

Over-Temperature Alarm Setting  °F

Heat Exhaust Limit  °F

Cool Exhaust Limit  °F

Shutdown Dryer on Bad Blowdown

Shutdown Dryer on Bad Repressurization

Use 2% Purge Cooling

LOG IN

LOG OUT

Home

Next

Previous

Snapshot

216

**Control Air Pressure**

Regeneration will pause when the inlet pressure drops 10 psi (68 kPa) below the settings. Regeneration will resume when the pressure rises above the setting.

**Purge Temperature**

Maintains purge temperature at this level during heating.

**Over-temp Temperature**

Shuts down dryer if purge temperature sensor rises above this setting. This is independent of external over-temp alarm.

**Heat Exhaust Limit / Enable**

Halts heating 5 minutes after exhaust temperature rises above setting.

**Cool Exhaust Limit / Enable**

Halts Cooling 5 minutes after exhaust temperature falls below setting.

**Enable Shutdown Dryer on Bad Blow down**

If this setting is enabled, the dryer will alarm and regeneration will shut down if the tower pressure is over 10 psi at the end of the blow-down time.

If this setting is disabled, the dryer will wait indefinitely until the tower pressure drops below 10psi before proceeding to regeneration.

**Enable Shutdown Dryer on Bad Repressurization**

If this setting is enabled, the dryer will alarm and regeneration will shut down if the tower pressure is not within 10 psi of the inlet pressure at the end of the repressurization time.

If this setting is disabled, the dryer will wait indefinitely for the tower pressure to rise to within 10 psi of inlet pressure before proceeding to regeneration.

Use 2% Purge Cooling (Blower Models Only). Enable to use dry purge air during cooling on blower units, otherwise, ambient air will be used, which will result in higher dewpoint spikes after switching.

**Factory Settings**

These settings are only available to the Dryer Manufacturer’s Factory or Service Personnel and are included here for reference only.

The screenshot displays the 'Factory Settings' screen with the following details:

- Model Type:** not set
- Dry Purge (TWP):** Enabled (indicated by a green dot)
- Blower Purge (TWB):** Disabled (indicated by a grey dot)
- Heated Operation Settings:**
  - Heated Drying Time: 240 Min
  - Heating Time: 150 Min
  - Cooling Time: 58 Min
  - Heated Repressurization Time: 180 Sec
  - Blower Cooldown Time: 2 Min
  - Ambient Cooling Time: 25 Min
  - Extended Dry Purging Time: 60 Min
- Heatless Operation Settings:**
  - Heatless Drying Time: 420 Sec
  - Heatless Repressurization Time: 60 Sec
  - Inlet Swing Time: 2 Sec
  - Tank Blow Down: 60 Sec
  - Heater Banks: 1
  - Dual Acting Valves: ENABLED
  - Outlet Filter Pressure: ENABLED
  - Use Pre-Exhaust Outputs: ENABLED
- Navigation and Actions:**
  - Buttons: Store Factory Settings, Restore Factory Settings, LOG IN, LOG OUT
  - Navigation: Home (Home icon), Next (Next icon), Previous (Previous icon), Snapshot (Snapshot icon)
  - Page Number: 218

These settings are only available to the Dryer Manufacturer’s Factory or Service Personnel and are included here for reference only.

Historical Trend Display

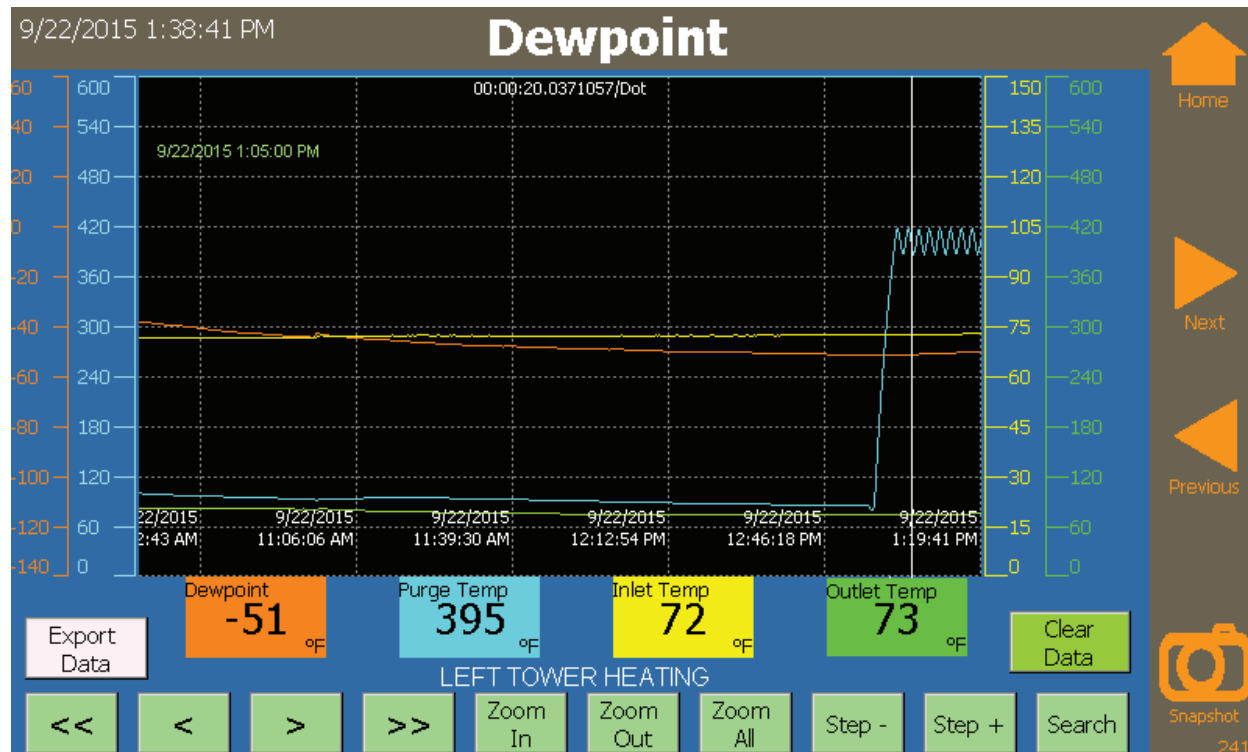

There are 5 trend windows, each focusing on different data groups.

When you first enter a trend display, you must hit ZOOM ALL to zoom out to a usable window.

The screen is historical data only and will not automatically update as new data is logged. To refresh the data, you must hit one of the zoom buttons.

Use RIGHT and LEFT ARROW keys to move between trend screens.

The following trends screens exist.

- Dewpoint**
  - Dewpoint
  - Purge Temperature
  - Inlet Temperature
  - Outlet Temperature
  
- System Pressure**
  - Inlet Pressure
  - Outlet Pressure
  - Left Pressure
  - Right Pressure
  
- Purge Temperature**
  - Purge Temperature
  - Left Temperature
  - Right Temperature
  - Purge Pressure (Dry Purge Models Only)

**Exhaust Temperature** Left Pressure  
Right Pressure  
Left Temperature  
Right Temperature

**Filter Pressure** Inlet Filter Pressure  
Outlet Filter Pressure  
Inlet Pressure  
Outlet Pressure

**User Sensor Inputs** Inlet Pressure  
Dewpoint  
User Sensor #1  
User Sensor #2

**Trend Elements**

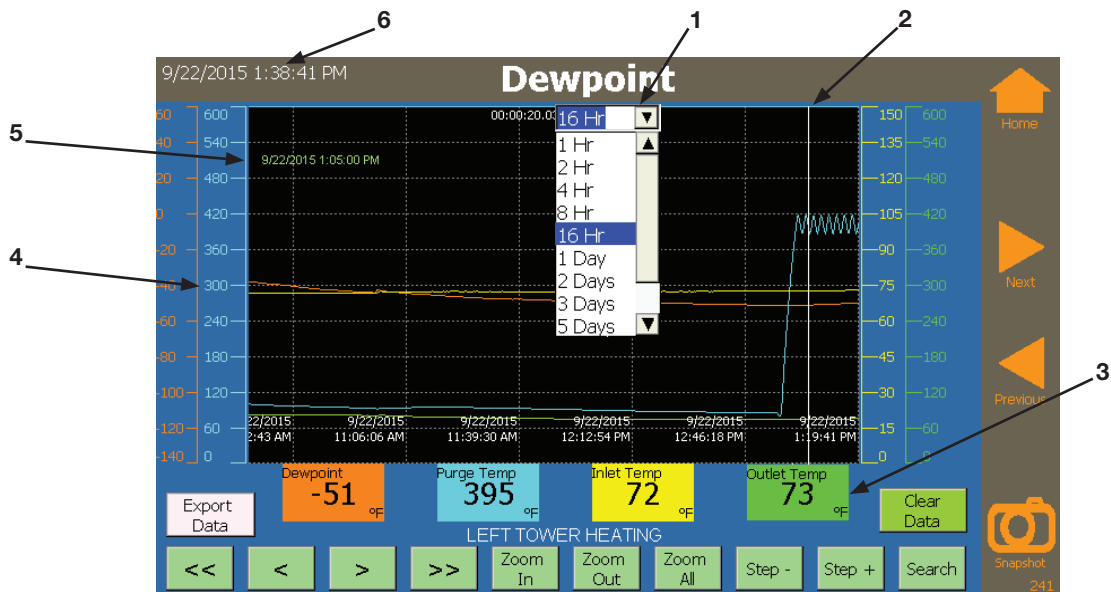

1. Time frame selection – select from 1 hr to 2 weeks.
2. Cursor line – drag or touch display to re-position.
3. Value box – data value at cursor position.
4. Scale – determined by the data type.
5. Time at cursor line – shows time at cursor line.
6. Current Time – system time.

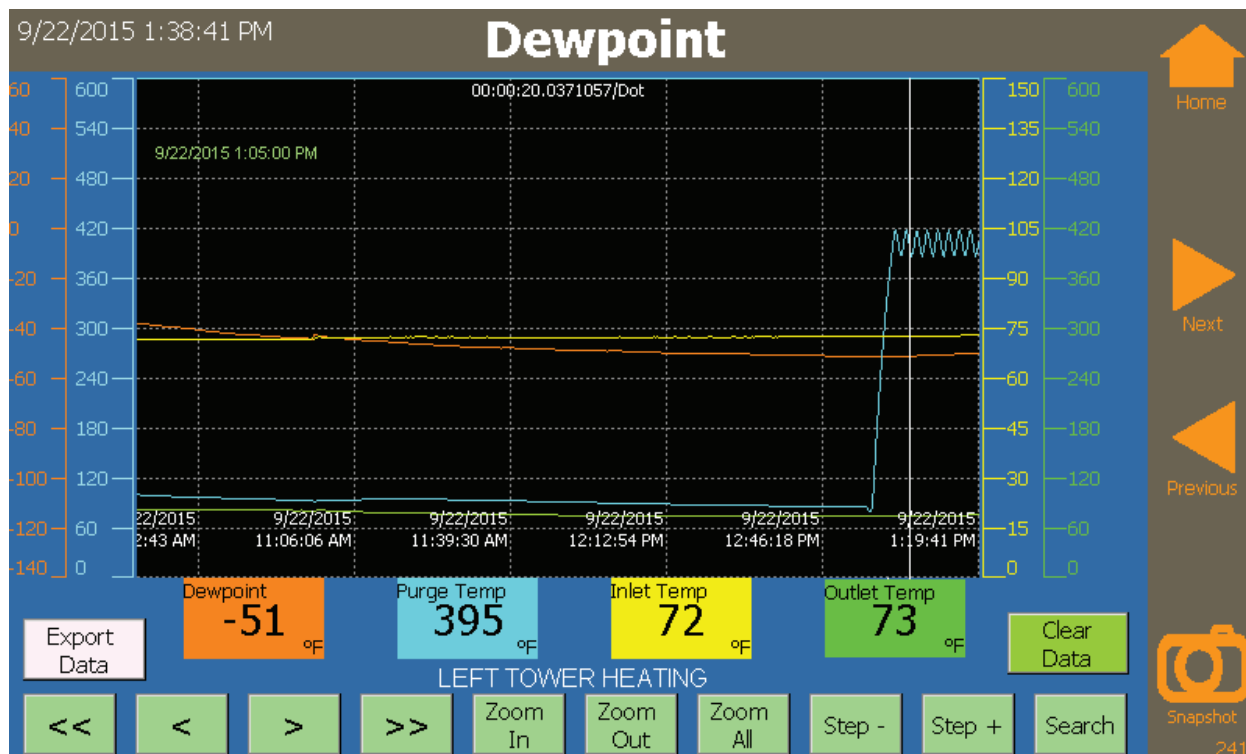

- Export Data**                 Sends data to the Flash Port in Excel readable format.
- Clear Data**                 Clear data log.
- <<**                             Move to earliest available data.
- <**                             Page Left.
- >**                             Page Right.
- >>**                          Move to latest available data.
- Zoom In**                    Zoom In one level, centered on the cursor.
- Zoom Out**                  Zoom Out one level, centered on cursor.
- Zoom Reset**                Resets Zoom to 24 Hours.
- Zoom All**                   Zooms Out to 24 Hours.
- Step Cursor Left**         Moves cursor left one unit (resolution unit).
- Step Cursor Right**        Moves cursor right one unit (resolution unit).
- Search**                     Opens a search window where a date and time can be entered.

**Note:** Changing the time to a value that is prior to the latest logged value will suspend trend user interaction until the clock catches up to and surpasses the latest logged value. This will result in loss of data and possible confusion. To prevent data loss, the data can be exported before the clock is changed, then cleared after the clock is changed. All logged data will be lost, however.



**Sensor Screen**

Displays real time sensor values. This is the only place that the User Input 2 is displayed.

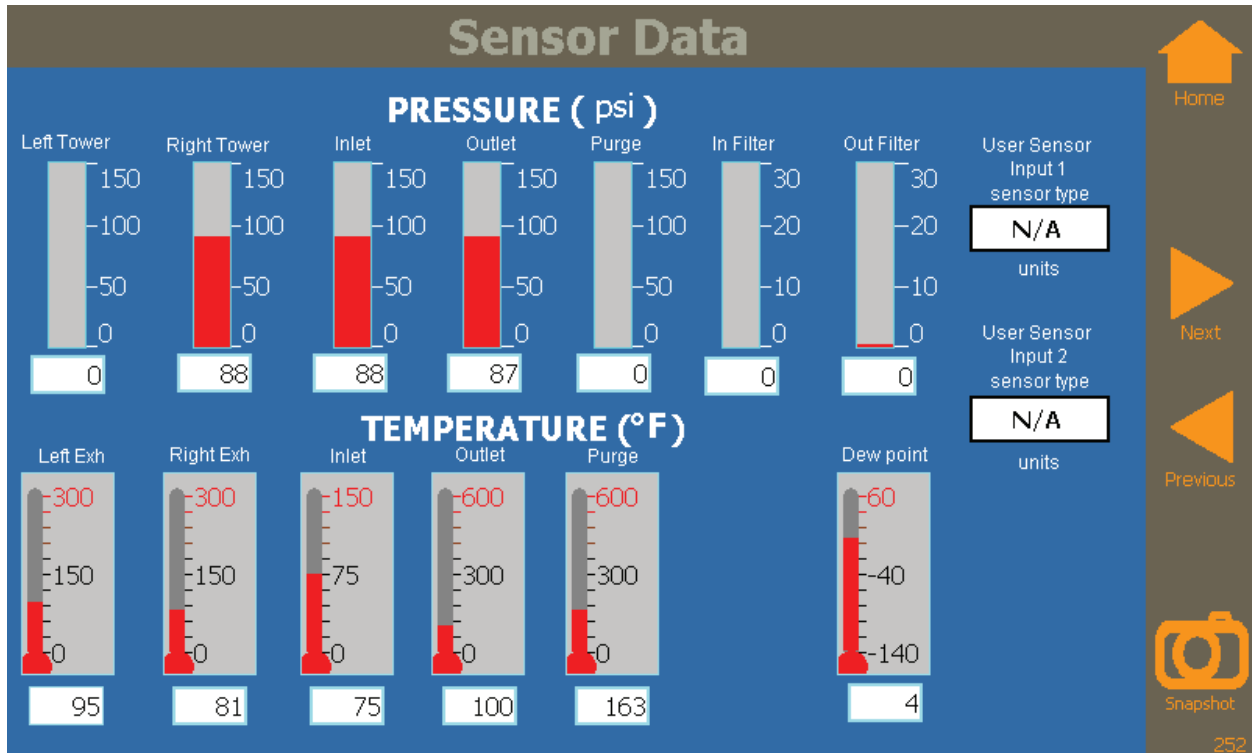

**I / O Screens**

Displays real time PLC inputs and Outputs for use in trouble shooting.

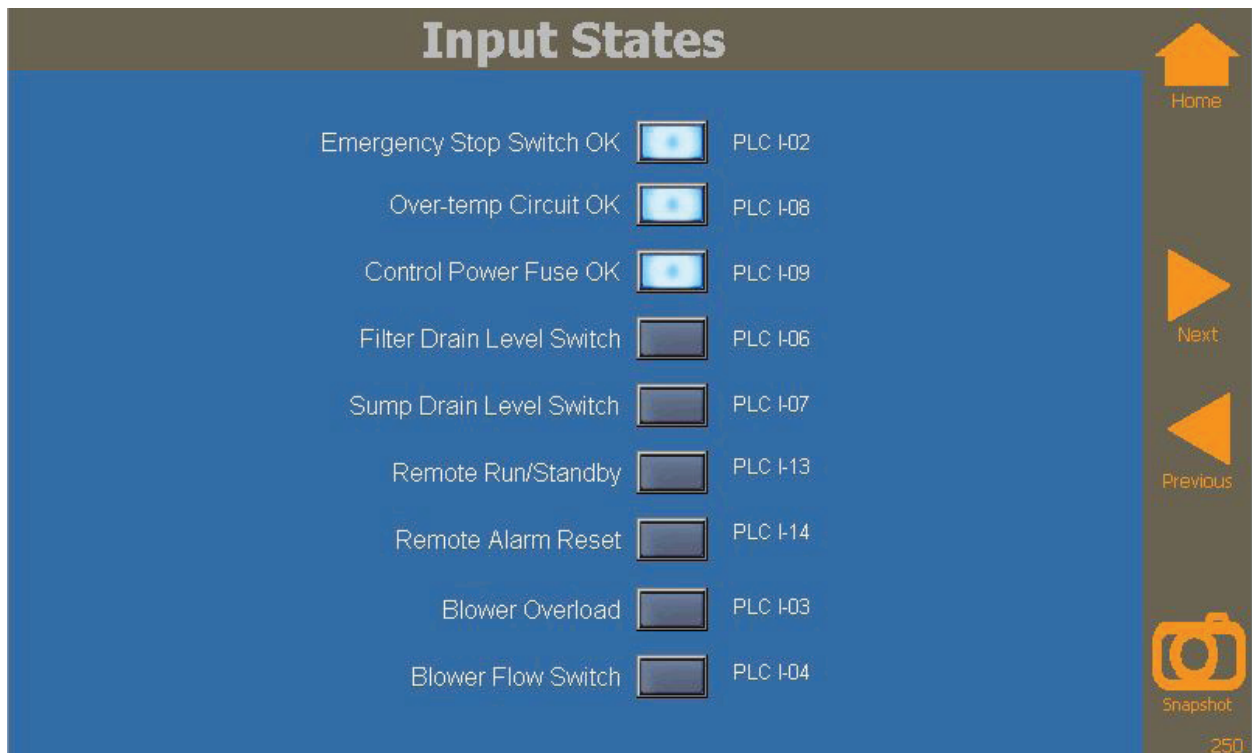



## Output States

Open Left Inlet Valve <input checked="" type="checkbox"/> PLC 0-16	Open Repressurization Valve <input checked="" type="checkbox"/> PLC 0-01
Close Left Inlet Valve <input type="checkbox"/> PLC 0-18	Blower Motor <input type="checkbox"/> PLC 0-06
Open Right Inlet Valve <input type="checkbox"/> PLC 0-17	Overtemp Contactor <input type="checkbox"/> PLC 0-07
Close Right Inlet Valve <input checked="" type="checkbox"/> PLC 0-19	Heater #1 Contactor <input type="checkbox"/> PLC 0-08
Open Left Blowdown Valve <input type="checkbox"/> PLC 0-12	Heater #2 Contactor <input type="checkbox"/> PLC 0-09
Open Right Blowdown Valve <input type="checkbox"/> PLC 0-13	Heater #3 Contactor <input type="checkbox"/> PLC 0-10
Open Left Exhaust Valve <input type="checkbox"/> PLC 0-14	Heater #4 Contactor <input type="checkbox"/> PLC 0-11
Open Right Exhaust Valve <input type="checkbox"/> PLC 0-15	Alarm Relay <input type="checkbox"/> PLC 0-00
Open Purge Valve <input type="checkbox"/> PLC 0-03	Open Filter Drain Valve <input type="checkbox"/> PLC 0-04
Purge Stop Valve <input type="checkbox"/> PLC 0-02	Open Sump Drain Valve <input type="checkbox"/> PLC 0-05

  
Home

  
Next

  
Previous

  
Snapshot

251

**Service Screen**

## Service

BACKUP  
PLC  
SETTINGS

RUNNING IN  
HEATED  
OPERATION

SWITCH TO  
HEATLESS  
OPERATION

RESTORE  
PLC  
SETTINGS

TEST  
DRAINS

REFERENCE  
GUIDE

REBOOT  
DISPLAY

LOG IN

EXIT  
PROGRAM

Touch to Set Time/Date  
**9/22/2015 2:00:51 PM**

LOG OUT

  
Home

  
Snapshot

220



42

**1. Heated and Heatless Operation Mode Buttons**

Press to start dryer, or switch between heated and heatless mode.

When switching modes, you must wait for the mode transition to complete before you can switch back.

**2. Test Drains**

Press to open the drain valve for the amount of time determined by Drain Duration setting.

**3. Backup and Restore PLC Settings**

Used to store a copy of the PLC settings so they can be transferred to a replacement PLC.

**4. Reboot Display**

Used to reboot the display panel should it be necessary.

An alternate method is to pull the orange plug on the back of the display panel.

**5. Exit to System**

Exits the application so that system level settings, such as communications can be accessed.

**6. Time/Date Set**

Press to adjust the time and date.

See note in trending section for possible effects on data logging and trends.

**7. Reference Guide**

Press to access Reference Guide.

Use the onboard reference guide to learn about and troubleshoot dryer functions.

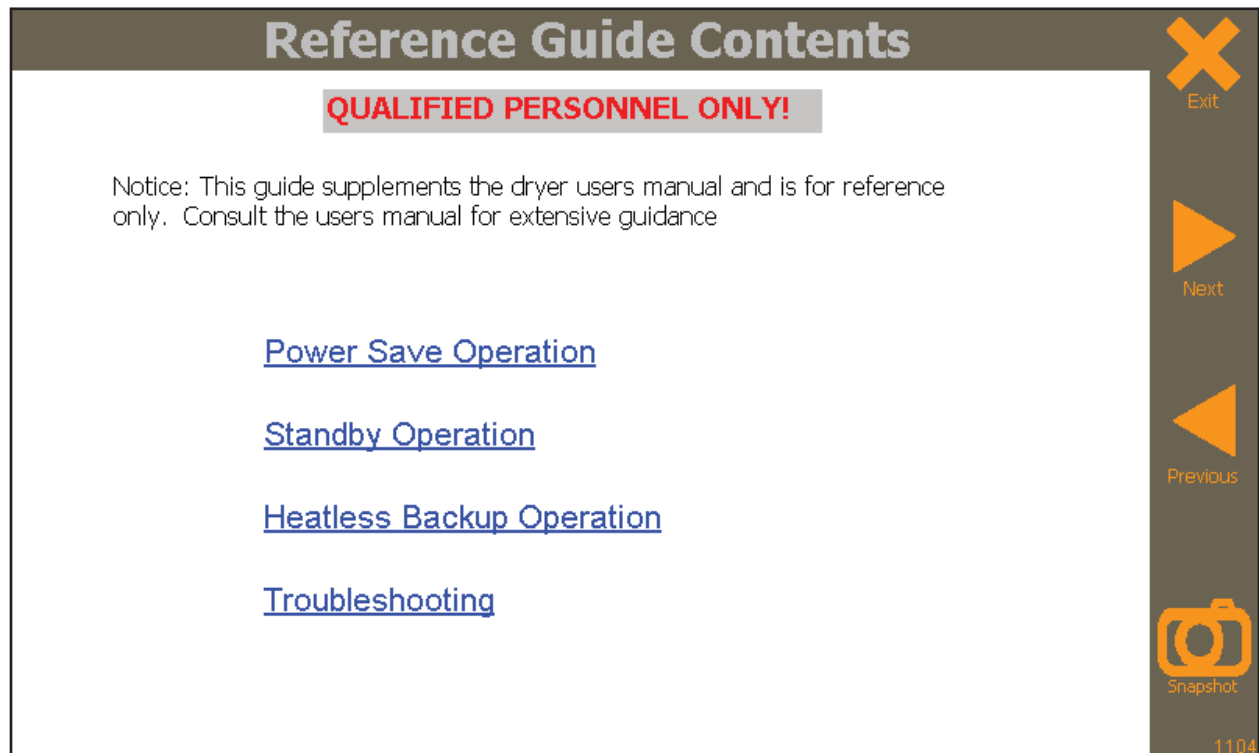

Service Screen

Refer to this screen for contact and machine information.  
 Only users with Factory or Service level access can change this information.

Alarm Indicator Display

Indicators will display in RED for all active alarms.  
 Pressing the indicator will display troubleshooting information relating to the alarm.

Alarm History

The screenshot displays the 'Alarm History' interface. At the top, the title 'Alarm History' is centered. Below it is a table with four columns: 'No.', 'ActiveTime', 'Type', and 'Message'. The table contains six rows of data. To the right of the table is a vertical sidebar with four orange icons: a home icon labeled 'Home', a right-pointing triangle labeled 'Next', a left-pointing triangle labeled 'Previous', and a camera icon labeled 'Snapshot'. At the bottom of the interface is a blue control panel with several buttons: 'Clear History', 'Save to File', two arrow buttons (up and down), 'LOG IN', 'LOG OUT', and a 'Snapshot' button with a camera icon. The number '232' is visible in the bottom right corner of the interface.

No.	ActiveTime	Type	Message
6	9/22/2015 1:54:47 PM	HiAlarm	HIGH DEW POINT
5	9/22/2015 1:53:38 PM	Event	REMOTE STANDBY DISABLED
4	9/22/2015 1:53:38 PM	Event	STANDBY DISABLED
3	9/22/2015 1:53:38 PM	Event	HEATLESS MODE
2	9/22/2015 1:53:38 PM	Event	MANUAL STEPPING DISABLED
1	9/22/2015 1:53:38 PM	ClearAl...	

Displays a log of all alarm and event activity since the last time the history log was cleared.

**User Buttons**

**Page Up / Down** – Move up and down thru menu.

**Clear History** – Clears the alarm history (use with caution).

**Save to File** – Save history to Excel readable file on flash drive.

## Active Alarms List Screen

N..	ActiveTime	Message
1	9/22/2015 1:54:47 PM	HIGH DEW POINT

Displays all active alarms.

Pressing Alarm Reset Button will reset all active alarms and automatically restart the dryer.

#### Alarm Relay

There is an alarm contact on the PLC for driving external alarm devices or for feeding into a PLC.

The alarm relay turns on whenever there is a new alarm and turns off when the alarm silence or alarm reset button is pressed.

#### Alarm Reset

Clears all alarms and restarts regeneration.

# ALARM CHART

Alarm	Description	Settings	Notes
TOWER FAILED TO BLOWDOWN	Alarms if regenerating tower is not above 10 psi at the end of blowdown.	Default is 60 seconds Adjustable from 15 to 300 seconds	Shuts down regeneration (settable) Manual reset
TOWER FAILED TO PRESSURIZE	Alarms if regenerating tower is not within 10 psi of the drying tower pressure when attempting to switch towers.	Always enabled	Shuts down regeneration Manual reset
SWITCHING FAILURE	Alarm occurs whenever the pressure drop across the inlet valve (including the filter) rises above 15psi (10kPa) for 2 seconds	Always enabled	Manual reset Does not shutdown regeneration. Inlet will not open under high diff. pressure
HIGH PURGE TEMPERATURE	Alarms if the purge temperature rises above the high purge temperature set point.	Default is 650°F (343°C), Always enabled Adjustable from 200°F to 800°F (93°C to 425°C)	This heater is inactive until the alarm is manually reset. This alarm does not shutdown regeneration.
HIGH OVER TEMPERATURE	Alarms if the alarm contact from the external over-temp monitor are closed.	Default is 650 °F, Always enabled	The heater is inactive until the alarm is manually reset.
LOW PURGE TEMPERATURE	Alarms if the purge temperature does not rise above 150 F within 15 minutes after the heater turns on.	Adjustable from module Fixed at 150°F (65°C)	This alarm does not shutdown regeneration. This heater is inactive until the alarm is manually reset.
CLOGGED MUFFLER	Alarms if the pressure in the regenerating tower is above 5 psi for 5 minutes	Always enabled Fixed at 5 psi (34 kPa)	This alarm does not shutdown regeneration. Automatically resets after pressure falls below setting
LOW PURGE PRESSURE (models without blowers only)	Alarms if the purge pressure is below the set point for 10 seconds during regeneration	Default is 25 psi (170 kPa), Always enabled	Automatically resets after pressure rises above setting
HIGH INLET TEMPERATURE	Alarm results when inlet temperature is above 101 F	Adjustable from 0 to 100 psi (0 to 650 kPa) Default is 103°F (38°C), Always enabled	Automatically resets when the temperature falls below the set point
LOW INLET PRESSURE	User settable alarm results when inlet pressure is below 60 psi for 5 minutes	Adjustable from 0°F to 200°F (0°C to 90°C) Default is 60 psi (414 kPa), User Enabled	Automatically resets when the pressure rises above the set point
HIGH DEW POINT	Alarms if the dew-point is above the set point for 45 minutes	Adjustable from 0 to 200 psi (0 to 1300 kPa) Default is -20°F (-28°C), User Enabled	Automatically resets when the dew point rises above the set point
CLOGGED PRE-FILTER	Difference between inlet pressure and drying tower pressure is greater than 8 psi for 5 minutes	Adjustable from -250°F to 75°F (-150°C to 20°C) Default is 8 psi (55 kPa), User Enabled	Automatically resets when the pressure drops below the set point
CLOGGED AFTER-FILTER	Difference between outlet pressure and drying tower pressure is greater than 8 psi for 5 minutes	Adjustable from 0 to 15 psi (0 to 100 kPa) Default is 8 psi (55 kPa), User Enabled	Automatically resets when the pressure drops below the set point
BLOWER OVERLOAD ALARM (models with blowers only)	Blower overload contact has opened while the blower is running.	Adjustable from 0 to 15 psi (0 to 100 kPa) Blower FLA adjustment on device	Manual reset to restart the dryer
BLOWER FLOW ALARM (models with blowers only)	Flow switch does not agree with blower output for 30 seconds.	none	Manual reset to restart the dryer
DRAIN FAULT	Drain switch input is closed for 5 seconds longer than Duration setting	Use Drain Duration setting	Automatically resets once the switch returns to normal
LOW AUX SENSOR	Alarms when input falls below setpoint	Default is 0, User Enabled Adjustable from -32767 to 32768	Automatically reset when value rises above setpoint
HIGH AUX SENSOR	Alarms when input rises above setpoint	Default is 0, User Enabled Adjustable from -32767 to 32768	Automatically reset when value drops below setpoint
LOSS OF CONTROL POWER	Alarms if there is no voltage on the output of the control fuse.	none	Must be manually reset by the operator
LOSS OF SENSOR POWER	Alarms if all pressures sensors register a fault.	none	Must be manually reset by the operator
EMERGENCY STOP	Emergency Stop button has been pressed.	none	
INLET, or TANK PRESSURE SENSOR FAULT	Sensor input is open or shorted to ground or V+	none	Shuts down regeneration Must be manually reset by the operator
OUTLET or PURGE PRESSURE SENSOR FAULT	Sensor input is open or shorted to ground or V+	none	Must be manually reset by the operator
DEWPOINT SENSOR FAULT	Sensor input is open or shorted to ground or V+	none	Automatically reset once the fault condition clears
AUX SENSOR FAULT	Sensor input is open or shorted to ground or V+	none	Automatically reset once the fault condition clears
TEMPERATURE SENSOR FAULT	Alarms if there is a break in the type 1 thermocouple sensor	none	Must be manually reset by the operator

## COMMUNICATIONS

**WARNING! - DO NOT ATTEMPT TO CHANGE SETTINGS OR OTHERWISE OPERATE THE DRYER REMOTELY WITHOUT A FIRM UNDERSTANDING OF DRYER OPERATION. IMPROPER SETTINGS OR CONTROL MAY RESULT IN DAMAGE TO DRYER COMPONENTS OR PHYSICAL INJURY.**

The user's panel includes an Ethernet and a Serial port which can be used for Modbus communications. The Ethernet port can be used to access Modbus/TCP registers, as well as, the internal VNC servers across multiple dryers. The Serial port can access Modbus RTU registers on a single dryer using either RS232 or RS422/485 hardware protocol.

### VNC Server

The internal VNC server runs in the back ground by default. Any VNC Client may be used to access the dryer's VNC server via port 5900.

Excessive network traffic or network interference may cause the VNC server to intermittently shut down. Rebooting the HMI via the Service menu or via Modbus register 40101 will restore the VNC Server after reboot.

### Ethernet

The Ethernet port is pre-configured to acquire its network IP address and configuration from the network's DHCP server. Proper cabling and isolation techniques are required to prevent electrical noise from entering the system through this port. Contact your local electrical parts distributor for assistance.

### Serial Modbus Port

The serial port is located along the bottom edge of the HMI. This port supports full RS232, RS422, and RS485 hardware protocols. This port is NOT isolated. Proper cabling and isolation techniques are required to prevent electrical noise from entering the system through this port. Contact your local electrical parts distributor for assistance.

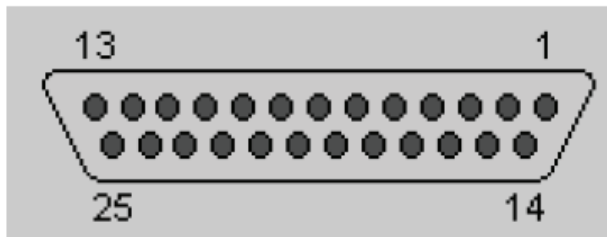

*DB25 Female Connector*

ID Address	<input type="text" value="101"/>
Baud Rate	<input type="text" value="38400 bps"/>
Parity	<input type="text" value="None"/>
Stop Bit	<input type="text" value="1 Bit"/>

*DB25 Female Connector  
Communication Settings*

DWG# ATE11605 Rev -



Pin Number	Signal	Signal Name	Signal Direction	Type
1	FG	Frame Ground	-	-
2	TD	Transmit Data	Output	RS232C
3	RD	Receive Data	Input	RS232C
4	RTS	Request to Send	Output	RS232C
5	CTS	Clear to Send	Input	RS232C
6	DSR	Data Set Ready	Input	RS232C
7	SG	Signal Ground	-	5V-/RS232C
8	DCD	Data Carrier Detect	Output	RS232C
9	-	-	-	-
10	-	-	-	-
11	-	-	-	-
12	TXDA	Transmit Data	Output	RS422/RS485
13	TXDB	Transmit Data	Output	RS422/RS485
14	RTSA	Request to Send	Output	RS422
15	RTSB	Request to Send	Output	RS422
16	-	-	-	-
17	-	-	-	-
18	CTSA	Clear to Send	Input	RS422
19	CTSB	Clear to Send	Input	RS422
20	DTR	Data Terminal Ready	Output	RS232C
21	5 V +	5 V Power Supply +	Output	-
22	RI	Ring Indicator	Input	RS232C
23	-	-	-	-
24	RXDA	Receive Data	Input	RS422
25	RXDB	Receive Data	Input	RS422

*DB25 Connector Pin-out*

**Notes:** Settings are not checked for proper range. Bounds checking must be done in the controlling computer. Setting a register outside of its stated range may result in unpredictable dryer operation.

## MODBUS REGISTER MAP

Address	R/W	Description	Notes
10001	R	Status - Heated Mode	Running in Heated mode
10002	R	Status - Heatless Mode	Running in Heatless mode
10003	R	Status - Switching to Heated	Switching from Heatless to Heated
10004	R	Status - Switching to Heatless	Switching from Heated to Heatless
10005	R	Status - Extended Drying Active	Variable drying time conditions met
10006	R	Status - Extended Dry Purge Active	Currently using extended dry purge
10007	R	Status - Stepping Allowed	Stepping is currently Allowed
10008	R	Status - Manual Stepping Active	Manual stepping is currently enabled
10009	R	Status - Run/Stop Status	Drying is currently running
10010	R	Status - Dryer is Parked	Dryer is in Standby
10011	R	Status - Heating Exhaust Limits Met	Heating exhaust conditions have been met
10012	R	Status - Cooling Exhaust Limits Met	Cooling exhaust conditions have been met
10013	R	Status - Shutdown	Currently shutdown due to alarm
10014	R	Status - Active alarm	There are current active alarms
10015	R	Status - Control Air	Control Air pressure is above its setting
10016	R	Status - Restarting Dryer	Dryer is currently restarting after an alarm
10017	R	Status - Repressurizing	Currently the dryer is repressurizing both tanks
10018	R	Status - Regenerating	Currently the dryer is regenerating in Heatless operation
10019	R	Status - Heating	Currently regenerating using heated air
10020	R	Status - Blower Cooling	Currently operating in the heating stage of regeneration
10021	R	Status - Ambient (Blower) Cooling	Currently using blower to provide ambient air for cooling
10022	R	Status - Stripping	Currently using dry purge air for cooling
10023	R	Status - Drying Side	0 = Left Tower Drying 1 = Right Tower Drying
10024	R	Status - Regeneration Side	1 = Left Tower Regenerating 0 = Right Tower Regenerating
10025	R	Status - Blowing Down	Regenerating tower is currently blowing down
10026	R	Status - Remote Shutdown	Remotely shutdown the dryer
10027	R	Status - Remote Standby	Remotely place the dryer in Standby
10028	R	Status - OK to Switch	Tank pressures are ok to switch towers or open exhaust valves
10033	R	Output - Alarm Relay	Relay is active
10034	R	Output - Repressurization Valve	Repressurization valve is open
10035	R	Output - Purge Stop Valve	Purge stop valve is closed (Blower Models Only)
10036	R	Output - Dry Purge Valve	Dry Purge valve is open (Externally Heated Models Only)
10037	R	Output - Drain #1 Valve	Drain valve is open
10038	R	Output - Drain #2 Valve	Drain valve is open
10039	R	Output - Blower Contactor	Blower is running (Blower Models Only)
10040	R	Output - Purge Heater Contactor	Heater is active
10041	R	Output - Over Temp Contactor	Over-temp contactor is closed allowing heating
10042	R	Output - Purge Heater Contactor Bank 2	Heater Bank #2 is active (Only dryers with Multi-Bank Heaters)
10043	R	Output - Purge Heater Contactor Bank 3	Heater Bank #3 is active (Only dryers with Multi-Bank Heaters)
10044	R	Output - Purge Heater Contactor Bank 4	Heater Bank #4 is active (Only dryers with Multi-Bank Heaters)
10045	R	Output - Left Pre-Exhaust Valve	Left pre-exhaust valve is open (Only dryers with pre-exhaust valves)

## MODBUS REGISTER MAP (CONT'D)

Address	R/W	Description	Notes
10046	R	Output - Right Pre-Exhaust Valve	Right pre-exhaust valve is open (Only dryers with pre-exhaust valves)
10047	R	Output - Left Exhaust Valve	Left Exhaust valve is open
10048	R	Output - Right Exhaust Valve	Right Exhaust valve is open
10049	R	Output - Open Left Inlet Valve	Left Inlet Valve is open (Dual acting Inlet valves only)
10050	R	Output - Open Right Inlet Valve	Right Inlet Valve is open (Dual acting Inlet valves only)
10051	R	Output - Close Left Inlet Valve	Left Inlet Valve is Closed
10052	R	Output - Close Right Inlet Valve	Right Inlet Valve is Closed
10066	R	Input - Sensor Power Sense	1 = sensor power present 0 = blown fuse or missing power
10067	R	Input - Emergency Stop Switch	1 = Normal switch position (No Emergency Stop ) 0 = Emergency Stop Pressed
10068	R	Input - Blower Overload	1 = Blower Overload (Blower Models only)
10069	R	Input - Blower Flow Switch	1 = Blower Flow Switch Closed (Active) (Blower Models only)
10071	R	Input - Drain Switch #1	1 = drain switch closed (Demand drains only)
10072	R	Input - Drain Switch #2	1 = drain switch closed (Demand drains only)
10073	R	Input - Over-temp Sense	1 = Over-temp module normal operation 0 = Over-temp module has tripped on high temperature. Heaters are disabled
10074	R	Input - Output Power Sense	1 = Output power is present, 0 = Blown fuse or missing power
10078	R	Input - Run/Stop Switch	1 = External Run/Standby Switch set to Standby Position
10079	R	Input - Remote Alarm Reset	1 = External contact closure resets Alarms and Restart Dryer
10081	R	Alarm - Left Blowdown	see separate alarm chart for details
10082	R	Alarm - Right Blowdown	see separate alarm chart for details
10083	R	Alarm - Left Repressurization	see separate alarm chart for details
10084	R	Alarm - Right Repressurization	see separate alarm chart for details
10085	R	Alarm - High Purge Temperature	see separate alarm chart for details
10086	R	Alarm - Low Purge Temperature	see separate alarm chart for details
10087	R	Alarm - High Over Temperature	see separate alarm chart for details
10089	R	Alarm - Left Muffler	see separate alarm chart for details
10090	R	Alarm - Right Muffler	see separate alarm chart for details
10091	R	Alarm - Low Purge Pressure	see separate alarm chart for details
10092	R	Alarm - Inlet Temperature	see separate alarm chart for details
10093	R	Alarm - Inlet Pressure	see separate alarm chart for details
10094	R	Alarm - High Dewpoint	see separate alarm chart for details
10095	R	Alarm - Pre-filter	see separate alarm chart for details
10096	R	Alarm - After-filter	see separate alarm chart for details
10097	R	Alarm - Blower Motor Overload	see separate alarm chart for details
10100	R	Alarm - Blower Flow Switch	see separate alarm chart for details
10101	R	Alarm - Drain #1 Switch	see separate alarm chart for details
10102	R	Alarm - Drain #2 Switch	see separate alarm chart for details
10103	R	Alarm - Aux Sensor Input #1 Low	see separate alarm chart for details
10104	R	Alarm - Aux Sensor Input #1 High	see separate alarm chart for details

MODBUS REGISTER MAP (CONT'D)			
10105	R	Alarm - Aux Sensor Input #2 Low	see separate alarm chart for details
10106	R	Alarm - Aux Sensor Input #2 High	see separate alarm chart for details
10112	R	Alarm - Control Power Fuse	see separate alarm chart for details
10115	R	Alarm - Sensor power Fuse	see separate alarm chart for details
10117	R	Alarm - Emergency Stop	see separate alarm chart for details
10130	R	Alarm - Right Tower Pressure Sensor Fault	see separate alarm chart for details
10131	R	Alarm - Inlet Pressure Sensor Fault	see separate alarm chart for details
10132	R	Alarm - Outlet Pressure Sensor Fault	see separate alarm chart for details
10133	R	Alarm - Purge Pressure Sensor Fault	see separate alarm chart for details
10134	R	Alarm - Dewpoint Sensor Fault	see separate alarm chart for details
10135	R	Alarm - Auxiliary Sensor Input #1 Sensor Fault	see separate alarm chart for details
10136	R	Alarm - Auxiliary Sensor Input #2 Sensor Fault	see separate alarm chart for details
10137	R	Alarm - Purge Temperature Sensor Fault	see separate alarm chart for details
10139	R	Alarm - Left Exhaust Temperature Sensor Fault	see separate alarm chart for details
10140	R	Alarm - Right Exhaust Temperature Sensor Fault	see separate alarm chart for details
10141	R	Alarm - Inlet Temperature Sensor Fault	see separate alarm chart for details
10142	R	Alarm - Outlet Temperature Sensor Fault	see separate alarm chart for details
30101	R	Left Tower Pressure	Pressure in PSI. See registers [40033]and [40041] for range
30102	R	Right Tower Pressure	Pressure in PSI. See registers [40034]and [40042] for range
30103	R	Inlet Pressure	Pressure in PSI. See registers [40035]and [40043] for range
30104	R	Outlet Pressure	Pressure in PSI. See registers [40036]and [40044] for range
30105	R	Purge Pressure	Pressure in PSI. See registers [40037]and [40045] for range
30106	R	Dewpoint	Dewpoint in F. See registers [40038]and [40046] for range
30107	R	Aux Sensor Input #1	User defined Input. See registers [40039]and [40047] for range
30108	R	Aux Sensor Input #2	User defined Input. See registers [40040]and [40048] for range
30110	R	Left Exhaust Temperature	Temperature from 0 to 1000 °F
30111	R	Right Exhaust Temperature	Temperature from 0 to 1000 °F
30112	R	Inlet Temperature	Temperature from 0 to 1000 °F
30113	R	Outlet Temperature	Temperature from 0 to 1000 °F
30114	R	Inlet Filter Pressure PSID	Differential pressure in PSID from -100 to 100. Calculated from difference between Inlet and Online Tank pressure.
30115	R	Outlet Filter Pressure PSID	Differential pressure in PSID from -100 to 100. Calculated from difference between outlet and Online Tank pressure.
30116	R	Control Setting - Dryer Operation Mode	Dryer operation 0 = Heatless 1 = Heated 2 = Switching to Heated 3 = Switching to Heatless
30117	R	State of Operation	Refer to separate State Table
30118	R	Time (Seconds) Remaining in Current State	Seconds left in current dryer state.
30120	R	Status Register #2	Mirrors bit registers 10017 thru 10032
30121	R	Alarms Register #1	Mirrors bit registers 10097 thru 10112
30122	R	Alarms Register #2	Mirrors bit registers 10113 thru 10128
30123	R	Alarms Register #3	Mirrors bit registers 10129 thru 10144
30124	R	Alarms Register #4	Mirrors bit registers 10145 thru 10160

MODBUS REGISTER MAP (CONT'D)			
30125	R	Control Outputs Register #1	Mirrors bit registers 10033 thru 10048
30126	R	Control Outputs Register #2	Mirrors bit registers 10049 thru 10064
30127	R	Switch Input Data Register #1	Mirrors bit registers 10065 thru 10080
30128	R	Switch Input Data Register #2	Mirrors bit registers 10081 thru 10096
40001	R/W	Alarm Set - Over Temperature	see separate alarm chart for details
40002	R/W	Alarm Set - High Inlet Temperature	see separate alarm chart for details
40003	R/W	Alarm Set - Low Inlet Pressure	see separate alarm chart for details
40004	R/W	Alarm Set - High Dewpoint	see separate alarm chart for details
40005	R/W	Alarm Set - High After-Filter Pressure	see separate alarm chart for details
40006	R/W	Alarm Set - High Pre-Filter Pressure	see separate alarm chart for details
40008	R/W	Alarm Set - Low Purge Temperature	see separate alarm chart for details
40009	R/W	Alarm Set - User Sensor #1 Low Setpoint	see separate alarm chart for details
40010	R/W	Alarm Set - User Sensor #1 High Setpoint	see separate alarm chart for details
40011	R/W	Alarm Set - User Sensor #2 Low Setpoint	see separate alarm chart for details
40012	R/W	Alarm Set - User Sensor #2 High Setpoint	see separate alarm chart for details
40013	R/W	Calibration - Sensor Min Set - Left Tower Pressure	Minimum sensor pressure. Default is 0 psi
40014	R/W	Calibration - Sensor Min Set - Right Tower Pressure	Minimum sensor pressure, Default is 0 psi
40015	R/W	Calibration - Sensor Min Set - Inlet Pressure	Minimum sensor pressure, Default is 0 psi
40016	R/W	Calibration - Sensor Min Set - Output Pressure	Minimum sensor pressure, Default is 0 psi
40017	R/W	Calibration - Sensor Min Set - Purge Pressure	Minimum sensor pressure, Default is 0 psi
40018	R/W	Calibration - Sensor Low Set - Dewpoint Probe	Minimum sensor dewpoint, Default is -148°F
40019	R/W	Calibration - Sensor Min Set - User Sensor #1	User adjustable input #1 minimum range. Default is 0. Refer to register 40039.
40020	R/W	Calibration - Sensor Min Set - User Sensor #2	User adjustable input #2 minimum range. Default is 0. Refer to register 40040.
40021	R/W	Calibration - Sensor Max Set - Left Tower Pressure	Maximum sensor pressure, Default is 200 psi
40022	R/W	Calibration - Sensor Max Set - Right Tower Pressure	Maximum sensor pressure, Default is 200 psi
40023	R/W	Calibration - Sensor Max Set - Inlet Pressure	Maximum sensor pressure, Default is 200 psi
40024	R/W	Calibration - Sensor Max Set - Outlet Pressure	Maximum sensor pressure, Default is 200 psi
40025	R/W	Calibration - Sensor Max Set - Purge Pressure	Maximum sensor pressure, Default is 200 psi
40026	R/W	Calibration - Sensor Max Set - Dewpoint Probe	Maximum dewpoint. Default is 68°F
40027	R/W	Calibration - Sensor Max Set - User Sensor #1	User adjustable input #1 maximum range, Default is 100
40028	R/W	Calibration - Sensor Max Set - User Sensor #2	User adjustable input #2 maximum range, Default is 100
40029	R/W	Calibration - Sensor Offset Set - Left Tower Pressure	Sensor offset, Default is 0 psi
40030	R/W	Calibration - Sensor Offset Set - Right Tower Pressure	Sensor offset, Default is 0 psi
40031	R/W	Calibration - Sensor Offset Set - Inlet Pressure	Sensor offset, Default is 0 psi
40032	R/W	Calibration - Sensor Offset Set - Outlet Pressure	Sensor offset, Default is 0 psi
40033	R/W	Calibration - Sensor Offset Set - Purge Pressure	Sensor offset, Default is 0 psi
40034	R/W	Calibration - Sensor Offset Set - Dewpoint Probe	Sensor offset, Default is 0°F
40035	R/W	Calibration - Sensor Offset Set - User Sensor #1	User adjustable input #1 offset
40036	R/W	Calibration - Sensor Offset Set - User Sensor #2	User adjustable input #2 offset
40037	R/W	Calibration - System Display Temperature Units	0 = F, 1 = C., Does not affect Modbus register units.

MODBUS REGISTER MAP (CONT'D)			
40038	R/W	Calibration - System Display Pressure Units	0 = psi, 1 = kPa, 2 = bars, Does not affect Modbus register units.
40039	R/W	Calibration - User Sensor #1 Units	0 = none, 1 = %, 2 = flow (scfm), 3 = flow (metric), 4 = pressure (sys units), 5 = temp. (sys units), 6 = power (W), 7 = Current (Amps /10 ), 8 = Volts
40040	R/W	Calibration - User Sensor #2 Units	0 = none, 1 = %, 2 = flow (scfm), 3 = flow (metric), 4 = pressure (sys units), 5 = temp. (sys units), 6 = power (W), 7 = Current (Amps /10 ), 8 = Volts
40041	R/W	Control Set - Heated - Drying Time	Factory Setting, dryer tower drying time, Default is 240 minutes per tower
40042	R/W	Control Set - Heated - Heat Purge Time	Factory Setting, Regeneration heating time, Default is 150 minutes
40043	R/W	Control Set - Heated - Cooling Purge Time	Factory Setting, Regeneration total cooling time, Default is 87 minutes
40044	R/W	Control Set - Heated - Blower Cool-down Time	Factory Setting, Time for cooling down heater tube. Default is 2 minutes, Blower models only
40045	R/W	Control Set - Heated - Ambient Cooling Time	Factory Setting, Ambient cooling time. Default is 25 minutes, (Blower models only)
40046	R/W	Control Set - Heated - Extended Dry Purging Time	Factory Setting, Maximum extended cooling time. Default is 60 minutes, (Blower models only)
40047	R/W	Control Set - Heated - Repressurization Time	Factory Setting, Repressurization Time, default is 180 seconds
40048	R/W	Control Set - Tank Blowdown Time	Factory Setting, Tower blowdown time, default is 120 seconds.
40049	R/W	Control Set - Heatless - Drying Time	Factory Setting, Heatless Drying Time. Default is 420 seconds
40050	R/W	Control Set - Heatless - Repressurization Time	Factory Setting, Heatless Repressurization Time, Default is 60 seconds.
40051	R/W	Control Set - Inlet Swing Time	Factory Setting, Time allocated for controlling inlet valves, Default is 2 seconds.
40052	R/W	Control Set - Heating Exhaust Limit	Exhaust Limit setting from 100°F to 250°F, Default is 150°F
40053	R/W	Control Set - Cooling Exhaust Limit	Exhaust Limit setting from 0°F to 150°F, Default is 150°F
40054	R/W	Control Set - Purge Temperature	Purge temperature from 0°F to 600°F, Default is 400°F
40055	R/W	Control Set - Instrument Air Pressure	Control air pressure from 10 to 200 psi, Default is 60 psi
40056	R/W	Control Set - Variable Cycle Dewpoint Threshold	Dewpoint demand setting, Default is -40°F
40057	R/W	Control Set - Number of Heater Banks	Factory Setting, Number of heater banks to control from 1 to 4
40058	R/W	Control Set - Drain 1 Interval in seconds	Drain interval time from 10 to 3600 seconds, Default is 600 seconds (10 minutes)
40059	R/W	Control Set - Drain 1 Duration	Minimum amount of time to open drain. Default is 10 seconds
40060	R/W	Control Set - Drain 1 Auto test in minutes	Automatically fire demand drain every 720 minutes, Settable from 30 to 1440
40061	R/W	Control Set - Drain 2 Interval in seconds	Drain interval time from 10 to 3600 seconds, Default is 600 seconds (10 minutes)
40062	R/W	Control Set - Drain 2 Duration	Minimum amount of time to open drain, Default is 10 seconds
40063	R/W	Control Set - Drain 2 Auto test in minutes	Automatically fire demand drain every 720 minutes, Settable from 30 to 1440
40064	R/W	Control Set - Drain 1 Type	0 = disabled, 1 = Use drain cycle time, 2 = Use demand switch
40065	R/W	Control Set - Drain 2 Type	0 = disabled, 1 = Use drain cycle time, 2 = Use demand switch
40066	R/W	Control Set - Model Type	0 = not set, 1 = Externally Heated, 2 = Blower Purge
40067	R/W	Control Setting - Start Dryer in Heated Mode	1 = switch from heatless to heated mode
40068	R/W	Control Setting - Start Dryer in Heatless Mode	1 = switch from heated to heatless mode

MODBUS REGISTER MAP (CONT'D)			
40069	R/W	Control Setting - Variable Cycling Time Enable	1 = Enable dewpoint demand function
40070	R/W	Control Setting - Extended Dry Purge	1 = Enable 2% dry purge feature, Blower model only
40071	R/W	Control Setting - Enable Manual Stepping	1= Enable manual stepping. 0 = Disable manual stepping. Use with Caution!
40072	R/W	Control Setting - Step to Next State	Set to 1 to step to the next state, 40072 must be set first, Caution! Do NOT Step out of cooling without considering the temperature in the regenerating tower. Instead, wait for cooling cycle to complete
40073	R/W	Control Setting - Remote Shutdown	Set to remotely shutdown the dryer
40074	R/W	Control Setting - Remote Standby	Set to remotely place the dryer in standby.
40075	R/W	Control Setting - Heating Exhaust Limits Enable	Default is 1, Heating Exhaust Limits are active
40076	R/W	Control Setting - Cooling Exhaust Limits Enable	Default is 0, Cooling Exhaust Limits are not active
40077	R/W	Control Setting - Enable Inlet Filter	Display inlet filter pressure and enable alarm
40078	R/W	Control Setting - Store Factory Settings	Store copy of settings in PLC
40079	R/W	Control Setting - Recall Factory Settings	Restore copy of settings in PLC
40080	R/W	Control Setting - Dewpoint Sensor Enable	Dewpoint sensor is installed
40081	R/W	Control Setting - Test Drains	Set to fire drains.
40084	R/W	Control Setting - Enable Dual Acting Valve	Factory Setting - Dryer uses dual acting inlet valves
40085	R/W	Control Setting - Enable Pre-Exhaust Outputs	Factory Setting - Dryer uses pre-exhaust valves
40086	R/W	Alarm Setting - Acknowledge Alarms	Set to silence the alarm display and turn off the alarm relay until next alarm occurs
40087	R/W	Alarm Setting - Clear all alarms	Reset all alarms, Restarts dryer if it is shutdown.
40088	R/W	Alarm Setting - Blowdown Alarm Enabled	see separate alarm chart for details
40089	R/W	Alarm Setting - Dewpoint Alarm Enabled	see separate alarm chart for details
40090	R/W	Alarm Setting - Low Inlet Pressure Alarm Enable	see separate alarm chart for details
40091	R/W	Alarm Setting - High Inlet Temp Alarm Enabled	see separate alarm chart for details
40092	R/W	Alarm Setting - After-Filter Alarm Enabled	see separate alarm chart for details
40093	R/W	Alarm Setting - Pre-Filter Alarm Enabled	see separate alarm chart for details
40094	R/W	Alarm Setting - Repressurization Alarm Enabled	see separate alarm chart for details
40095	R/W	Alarm Setting - Aux Sensor #1 Low Alarm Enabled	see separate alarm chart for details
40096	R/W	Alarm Setting - Aux Sensor #1 High Alarm Enabled	see separate alarm chart for details
40097	R/W	Alarm Setting - Aux Sensor #2 Low Alarm Enabled	see separate alarm chart for details
40098	R/W	Alarm Setting - Aux Sensor #2 High Alarm Enabled	see separate alarm chart for details
40099	R/W	User Sensor #1 Input Enable	Enables user input # 1
40100	R/W	User Sensor #2 Input Enable	Enables user input # 1
40101	R/W	Control - Reboot HMI Remotely	Remotely reboot the HMI, Useful if VNC server shuts down unexpectedly due to high network traffic

## SHUT DOWN

The dryer should be sufficiently cooled down and allowed to repressurize before shutting down. Allow dryer to run normally or use the manual stepping feature to proceed to the cooling stage and wait for cooling to end. After the regenerating tower has sufficiently cooled down, place the dryer into STANDBY.

If the dryer is operating in the heatless backup mode of operation, place the dryer immediately into stand by. Wait for the dryer to repressurize, then push the emergency stop button and open the main electrical disconnect.

Once the dryer is in STANDBY, the EMERGENCY STOP button can then be used to remove power from the valves, the heater, and the blower. Open the main electrical disconnect to completely remove power from the dryer.

To put dryer into STANDBY, press the SWITCH TO STANDBY button on the display. The GOING TO STANDBY message will appear on the screen. If pressed during the heating cycle, the dryer will proceed to cooling for two minutes. Once the dryer repressurizes, the status message will change to read DRYER IN STANDBY. Both tanks will be pressurized and the heater will remain off. To restart, press the DRYER IN STANDBY button on the display. The regeneration cycle will immediately resume at the point in the regenerating process where the stand by button was first pressed.

To depressurize the dryer, first follow the appropriate shutdown procedure. Open the dryer bypass valve. Close the outlet isolation valve, and then the inlet isolation valve.

Open the manual drain valve on the afterfilter or control air filter to allow full depressurization of the dryer. Verify all pressure is removed from equipment and power is disconnected before servicing.

If a dewpoint sensor is installed and the dryer will be out of service for an extended period of time, remove the sensor and place in a safe, dry location. The sensor will be damaged if exposed to prolonged periods of saturated conditions.

The dryer should be immediately bypassed to prevent loading the desiccant beds while the dryer is out of service.

## MAINTENANCE



Use caution when near the dryer and wear eye protection. Hearing protection is recommended. Dryer maintenance should only be performed by trained personnel. Always shutdown the dryer, relieve all pressure, and disconnect power before servicing.

**Consult service manual for additional information on part replacement.**

### Daily

Check the dewpoint of the compressed air system to ensure it is in good operating condition.

Check drain for proper function. Ensure drain is not clogged.

Check purge pressure setting (TWP only), proper prefilter drain operation, and verify no back pressure on regenerating vessel to avoid more serious operating issues.

Check for proper heater and desiccant bed temperatures.

Check controller for any active alarms.



**Weekly**

Check air flow rate, air inlet pressure and temperature are within design specifications of dryer.

Check blower and blower inlet filter. (Blower purge models only).

**Semi-annual**

Check the condition of the prefilter and afterfilter elements. Verify the differential pressure across the filters. Replace as needed.

Check desiccant quality. Desiccant from a freshly regenerated bed should be white, dry to the touch and of consistent size and shape. Continuous adsorption and desorption causes the performance level of desiccant to decline over time. Oil and contaminants causes reduction in the adsorption ability of the desiccant. It is recommended to replace the desiccant every 3-5 years.

Check exhaust mufflers and verify there is no back pressure in regenerating vessel. If the muffler is clogged, it must be cleaned or replaced.

Tighten wire connections to heater. Stud terminals should be tightened to a maximum torque of 20 in-lbs while the bottom nut is supported. Stud terminals that do not have a bussbar or factory installed ring connector should only be tightened to 9 in-lbs.

Check condition of blower inlet filter element and replace as needed. (Blower purge models only).

Inspect blower drive belt and idler pulley. Replace if needed. (Blower purge models 4001-7501 only).

**Annual**

Check condition of control air filter element. Replace as needed.

Check condition of all inlet and exhaust switching valves. It is recommended to clean and rebuild the valves to maintain proper working condition.

Check dewpoint sensor and recalibrate as needed.

Check contactors and starters. Replace as needed.

Inspect blower head, tensioner, and pulleys for correct operation. (Blower purge models 4001-7501 only.)

## Externally Heated Spare Parts List (Flow schematic drawing# FS11682)

	MODEL	TWP201	TWP251	TWP301
<b>DESICCANT</b>				
DESICCANT 25LB BAGS (QTY)	AV1, AV2	PDA-1/8-25 (12)	PDA-1/8-25 (16)	PDA-1/8-25 (20)
<b>FILTER ELEMENTS</b>				
COALESCER ELEMENT (QTY)	PF1, PF2	P030AA (1)	P035AA (1)	P035AA (1)
PARTICULATE ELEMENT (QTY)	AF1, AF2	JE-FC0350-HT (1)	JE-FC0350-HT (1)	JE-FC0350-HT (1)
CONTROL AIR FILTER ELEMENT (QTY)	CF1	TP2201-PE (1)	TP2201-PE (1)	TP2201-PE (1)
<b>REPAIR KITS</b>				
INLET VALVE REPAIR KIT	PV2, PV3	TP7615-P1-RK	TP7615-P1-RK	TP7615-P1-RK
EXHAUST VALVE REPAIR KIT	PV1, PV4	TP7510-P1-RK	TP7510-P1-RK	TP7510-P1-RK
OUTLET CHK VALVE REPAIR KIT	CV1	TP7415-SDX-RK	TP7415-SDX-RK	TP7415-SDX-RK
PURGE CHK VALVE REPAIR KIT	CV3, CV4, CV5, CV6	TP7405-AB-RK	TP7405-AB-RK	TP7405-AB-RK
<b>REPLACEMENT PARTS</b>				
INLET VALVE	PV2, PV3	TP7615-P1	TP7615-P1	TP7615-P1
EXHAUST VALVE	P1, PV4	TP7510-P1	TP7510-P1	TP7510-P1
OUTLET CHECK VALVE	CV1	TP7415-SDX	TP7415-SDX	TP7415-SDX
PURGE CHECK VALVE	CV3, CV4, CV5, CV6	TP7405-AB	TP7405-AB	TP7405-AB
REPRESSURIZATION VALVE	S5	TP8003	TP8003	TP8003
CONTROL SOLENOID VALVE	S1, S2B, S3B, S4	TP8101-1D	TP8101-1D	TP8101-1D
DRAIN VALVE	FD1, FD2	PD15NO	PD15NO	PD15NO
MUFFLER, EXHAUST	ES1, ES2	TP4210-1	TP4210-1	TP4210-1
FILTER, CONTROL AIR	CF1	TP2201-P	TP2201-P	TP2201-P
SAFETY RELIEF VALVE	PSV1, PSV2	TP7105	TP7105	TP7105
PRESSURE GAUGE	PI1, PI2, PI3	LP1020	LP1020	LP1020
PURGE ORIFICE	RO1	TP4418-0520	TP4418-0520	TP4418-0520
BACKUP PURGE ORIFICE	RO2	TP4112	TP4518	TP4518
FILTER DP GAUGE	DPI1, DPI2	ZD90GL	ZD90GL	ZD90GL
THERMOCOUPLE	TC1,TC2,TC3,TC4,TC5,TC6	TP2082-UNGRD	TP2082-UNGRD	TP2082-UNGRD
HEATER	HT1	TP3603-4	TP3603-4	TP3603-484
PRESSURE TRANSDUCER	PT1,PT2,PT3,PT4,PT5	TP2451	TP2451	TP2451
CONTACTOR	C1, C2	ES5040-2-120	ES5040-2-120	ES5050
PLC	PLC1	TP2681-PLC-P300	TP2681-PLC-P300	TP2681-PLC-P300
HMI DISPLAY	HMI	TP2681-HMI-P300	TP2681-HMI-P300	TP2681-HMI-P300
POWER SUPPLY		2080-PS120-240V	2080-PS120-240V	2080-PS120-240V
FUSE, 1 AMP	F1	EF0100-2-TD	EF0100-2-TD	EF0100-2-TD
FUSE, 2 AMP	F2	EF0200-2-TD	EF0200-2-TD	EF0200-2-TD
FUSE, 1/4 AMP	F3	EF0025-TD	EF0025-TD	EF0025-TD
MEMORY CARD		TP2681-MEM	TP2681-MEM	TP2681-MEM
DEWPOINT PROBE	AE1	TP2190-1-UL	TP2190-1-UL	TP2190-1-UL
<b>MODELS WITH NEMA 4</b>				
NEMA 4 THERMOCOUPLE	TC1,TC2,TC3,TC4,TC5,TC6	TP2083-N4	TP2083-N4	TP2083-N4
<b>MODELS WITH INSTRUMENTATION OPTION</b>				
PRESSURE GAUGE	PI4, P5	LP1020	LP1020	LP1020
TEMPERATURE GAUGE	TG1, TG2	LT3250-.25	LT3250-.25	LT3250-.25

## Externally Heated Spare Parts List (Flow schematic drawing# FS11683)

	MODEL	TWP401	TWP501	TWP601	TWP801
<b>DESICCANT</b>	<b>PART ID</b>	<b>PART NUMBER</b>			
DESICCANT 25LB BAGS (QTY)	AV1, AV2	PDA-1/8-25 (24)	PDA-1/8-25 (30)	PDA-1/8-25 (36)	PDA-1/8-25 (48)
<b>FILTER ELEMENTS</b>					
COALESCER ELEMENT (QTY)	PF1, PF2	P040AA (1)	P045AA (1)	P045AA (1)	P050AA (1)
PARTICULATE ELEMENT (QTY)	AF1, AF2	JE-FC0450-HT (1)	JE-FC0625-HT (1)	JE-FC0625-HT (1)	JE-FC0800-HT (1)
CONTROL AIR FILTER ELEMENT (QTY)	CF1	TP2201-PE (1)	TP2201-PE (1)	TP2201-PE (1)	TP2201-PE (1)
<b>REPAIR KITS</b>					
INLET VALVE REPAIR KIT	PV2, PV3	TP7620-P1-RK	TP7620-P1-RK	TP7620-P1-RK	TP7620-P1-RK
EXHAUST VALVE REPAIR KIT	PV1, PV4	TP7510-P1-RK	TP7515-P1-RK	TP7515-P1-RK	TP7515-P1-RK
PRE EXHAUST VALVE REPAIR KIT	PV7, PV8	TP7510-P1-RK	TP7510-P1-RK	TP7510-P1-RK	TP7510-P1-RK
OUTLET CHK VALVE REPAIR KIT	CV1	TP7420-SDX-RK	TP7420-SDX-RK	TP7420-SDX-RK	TP7420-SDX-RK
PURGE CHK VALVE REPAIR KIT	CV3, CV4, CV5, CV6	TP7405-AB-RK	TP7407-AB-RK	TP7407-AB-RK	TP7410-AB-RK
<b>REPLACEMENT PARTS</b>					
INLET VALVE	PV2, PV3	TP7620-P1	TP7620-P1	TP7620-P1	TP7620-P1
EXHAUST VALVE	P1, PV4	TP7510-P1	TP7515-P1	TP7515-P1	TP7515-P1
PRE EXHAUST VALVE	PV7, PV8	TP7510-P1	TP7510-P1	TP7510-P1	TP7510-P1
OUTLET CHECK VALVE	CV1	TP7420-SDX	TP7420-SDX	TP7420-SDX	TP7420-SDX
PURGE CHECK VALVE	CV3, CV4, CV5, CV6	TP7405-AB	TP7407-AB	TP7407-AB	TP7410-AB
REPRESSURIZATION VALVE	S5	TP8003	TP8003	TP8003	TP8003
CONTROL SOLENOID VALVE	S1, S2b, S3b, S4, S7, S8	TP8101-1D	TP8101-1D	TP8101-1D	TP8101-1D
DRAIN VALVE	FD1, FD2	PD15NO	PD15NO	PD15NO	PD15NO
MUFFLER, EXHAUST	ES1, ES2	TP4210-1	TP4210-1	TP4210-1	TP4210-1
FILTER, CONTROL AIR	CF1	TP2201-P	TP2201-P	TP2201-P	TP2201-P
SAFETY RELIEF VALVE	PSV1, PSV2	TP7105	TP7105	TP7105	TP7105
PRESSURE GAUGE	PI1, PI2, PI3	LP1020	LP1020	LP1020	LP1020
PURGE ORIFICE	RO1	TP4425-0525	TP4425-0525	TP4431-0515	TP4431-0515
BACKUP PURGE ORIFICE	RO2	TP4518	TP4122	TP4122	TP4125
FILTER DP GAUGE	DPI1, DPI2	ZD90GL	ZD90GL	ZD90GL	ZD90GL
THERMOCOUPLE	TC1,TC2,TC3,TC4,TC5,TC6	TP2082-UNGRD	TP2082-UNGRD	TP2082-UNGRD	TP2082-UNGRD
HEATER	HT1	TP3606	TP3606	TP3609	TP3609
PRESSURE TRANSDUCER	PT1,PT2,PT3,PT4,PT5	TP2451	TP2451	TP2451	TP2451
CONTACTOR	C1, C2	ES5050	ES5050	ES5050	ES5050
PLC	PLC1	TP2681-PLC-P800	TP2681-PLC-P800	TP2681-PLC-P800	TP2681-PLC-P800
HMI DISPLAY	HMI	TP2681-HMI-P800	TP2681-HMI-P800	TP2681-HMI-P800	TP2681-HMI-P800
POWER SUPPLY		2080-PS120-240V	2080-PS120-240V	2080-PS120-240V	2080-PS120-240V
FUSE, 1 AMP	F1	EF0100-2-TD	EF0100-2-TD	EF0100-2-TD	EF0100-2-TD
FUSE, 2 AMP	F2	EF0200-2-TD	EF0200-2-TD	EF0200-2-TD	EF0200-2-TD
FUSE, 1/4 AMP	F3	EF0025-TD	EF0025-TD	EF0025-TD	EF0025-TD
MEMORY CARD		TP2681-MEM	TP2681-MEM	TP2681-MEM	TP2681-MEM
DEWPOINT PROBE	AE1	TP2190-1-UL	TP2190-1-UL	TP2190-1-UL	TP2190-1-UL
<b>MODELS WITH NEMA 4</b>					
NEMA 4 THERMOCOUPLE	TC1,TC2,TC3,TC4,TC5,TC6	TP2083-N4	TP2083-N4	TP2083-N4	TP2083-N4
<b>MODELS WITH INSTRUMENTATION OPTION</b>					
PRESSURE GAUGE	PI4, P5	LP1020	LP1020	LP1020	LP1020
TEMPERATURE GAUGE	TG1, TG2	LT3250-.25	LT3250-.25	LT3250-.25	LT3250-.25

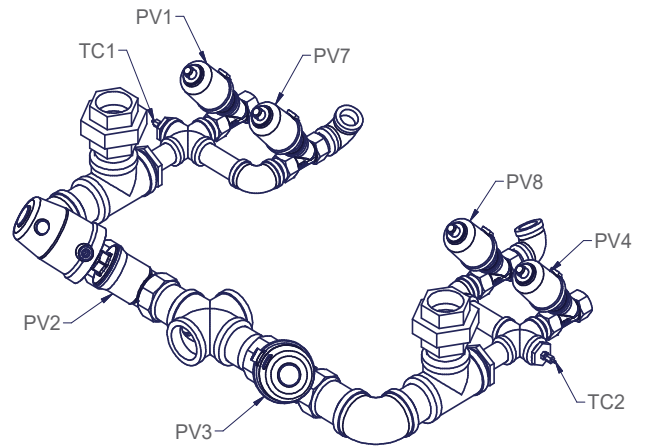
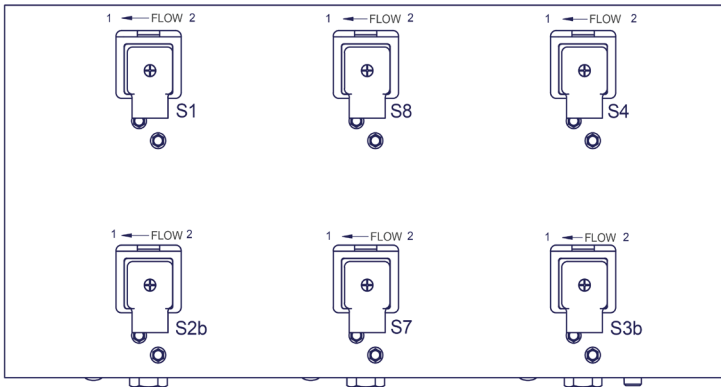
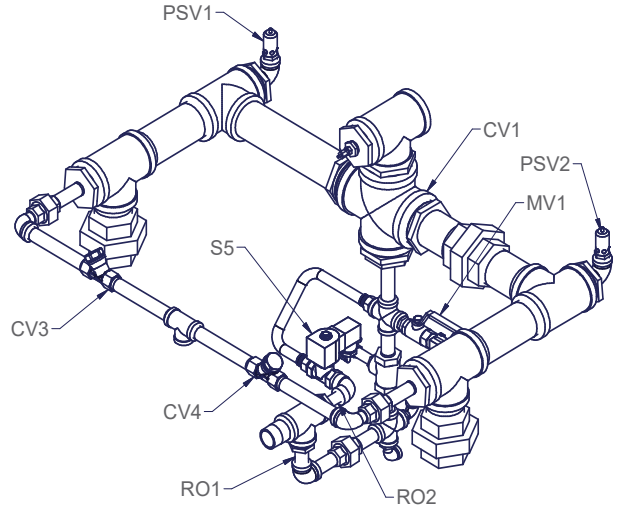

TWP401BY41NNN-MAN REV-

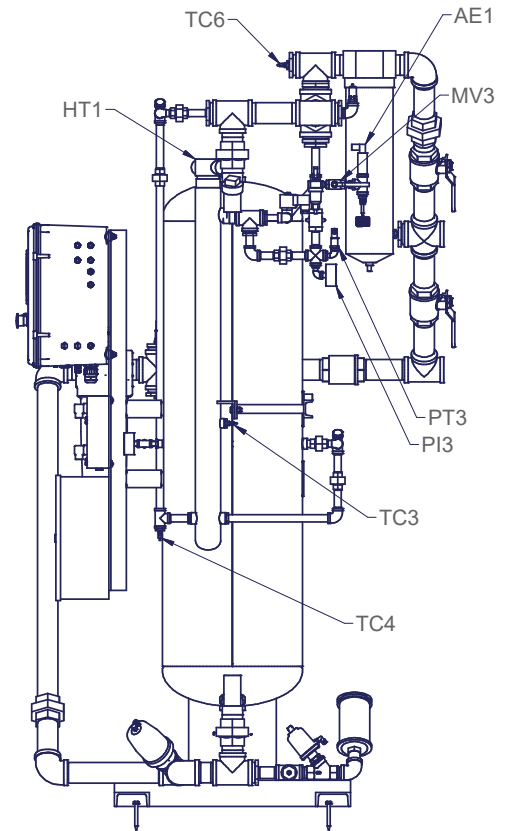
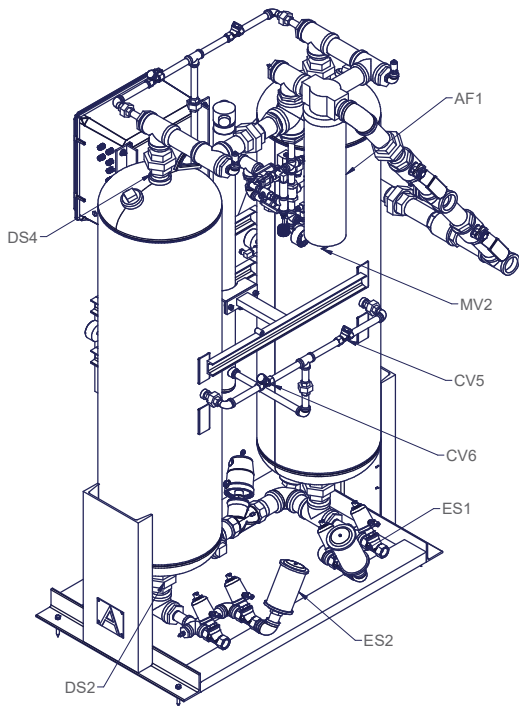
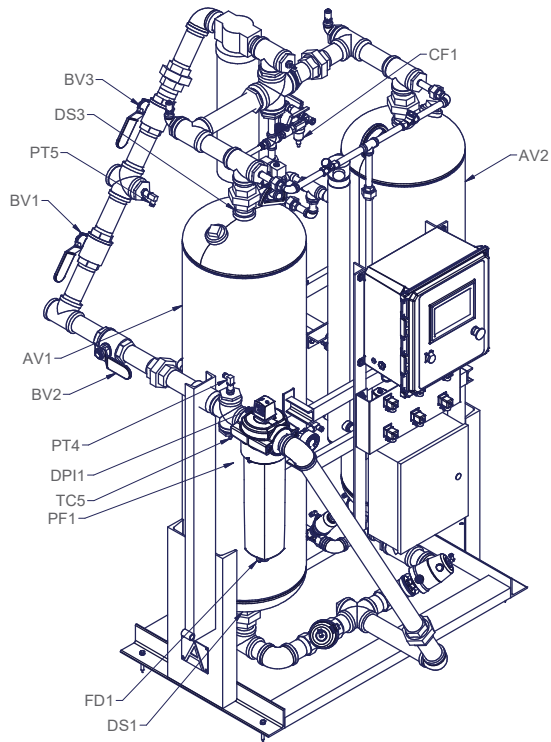

TWP401BY41NNN-MAN REV-

## Externally Heated Spare Parts List (Flow schematic drawing# FS11684)

	MODEL	TWP1001	TWP1201
<b>DESICCANT</b>			
	<b>PART ID</b>	<b>PART NUMBER</b>	
DESICCANT 25LB BAGS (QTY)	AV1, AV2	PDA-1/8-25 (60)	PDA-1/8-25 (70)
<b>FILTER ELEMENTS</b>			
COALESCER ELEMENT (QTY)	PF1, PF2	P055AA (1)	P055AA (1)
PARTICULATE ELEMENT (QTY)	AF1, AF2	JE-FC1330-HT (1)	JE-FC1330-HT (1)
CONTROL AIR FILTER ELEMENT (QTY)	CF1	TP2201-PE (1)	TP2201-PE (1)
<b>REPAIR KITS</b>			
INLET VALVE REPAIR KIT	PV2, PV3	TP7631-BD-HP-RK	TP7631-BD-HP-RK
INLET VALVE ACTUATOR	PV2, PV3	TP7631-BD-HP-A	TP7631-BD-HP-A
EXHAUST VALVE REPAIR KIT	PV1, PV4	TP7515-P1-RK	TP7515-P1-RK
PRE EXHAUST VALVE REPAIR KIT	PV7, PV8	TP7510-P1-RK	TP7510-P1-RK
OUTLET CHK VALVE REPAIR KIT	CV1, CV2	TP7431-SWRK	TP7431-SWRK
PURGE CHK VALVE REPAIR KIT	CV3, CV4, CV5, CV6	TP7410-AB-RK	TP7410-AB-RK
PURGE STOP VALVE REPAIR KIT	PV9	TP7610-P1-RK	TP7610-P1-RK
<b>REPLACEMENT PARTS</b>			
INLET VALVE	PV2, PV3	TP7631-BD-HP	TP7631-BD-HP
EXHAUST VALVE	P1, PV4	TP7515-P1	TP7515-P1
PRE EXHAUST VALVE	PV7, PV8	TP7510-P1	TP7510-P1
OUTLET CHECK VALVE	CV1, CV2	TP7431-SW	TP7431-SW
PURGE CHECK VALVE	CV3, CV4, CV5, CV6	TP7410-AB	TP7410-AB
REPRESSURIZATION CONTROL VALVE	S5	TP8003	TP8003
PURGE STOP VALVE	PV9	TP7610-P1	TP7610-P1
CONTROL SOLENOID VALVE	S2A, S2B, S3A, S3B	TP8101-1D	TP8101-1D
CONTROL SOLENOID VALVE	S1, S4, S7, S8, S9	TP8101-1D	TP8101-1D
DRAIN VALVE	FD1, FD2	PD15NO	PD15NO
MUFFLER, EXHAUST	ES1, ES2	TP4210-1	TP4210-1
FILTER, CONTROL AIR	CF1	TP2201-P	TP2201-P
SAFETY RELIEF VALVE	PSV1, PSV2	TP7110	TP7110
PRESSURE GAUGE	PI1, PI2, PI3	LP1020	LP1020
PURGE ORIFICE	RO1	TP4437-1021	TP4437-1021
BACKUP PURGE ORIFICE	RO2	TP4131	TP4131
FILTER DP GAUGE	DPI1, DPI2	ZD90GL	ZD90GL
THERMOCOUPLE	TC1,TC2,TC3,TC4,TC5,TC6	TP2082-UNGRD	TP2082-UNGRD
HEATER	HT1	TP3612	TP3612
PRESSURE TRANSDUCER	PT1,PT2,PT3,PT4,PT5	TP2451	TP2451
CONTACTOR	C1, C2	ES5050	ES5050
PLC	PLC1	TP2681-PLC-P1200	TP2681-PLC-P1200
POWER SUPPLY		2080-PS120-240V	2080-PS120-240V
HMI DISPLAY	HMI	TP2681-HMI-P1200	TP2681-HMI-P1200
FUSE, 1 AMP	F1	EF0100-2-TD	EF0100-2-TD
FUSE, 2 AMP	F2	EF0200-2-TD	EF0200-2-TD
FUSE, 1/4 AMP	F3	EF0025-TD	EF0025-TD
MEMORY CARD		TP2681-MEM	TP2681-MEM
DEWPOINT PROBE	AE1	TP2190-1-UL	TP2190-1-UL
<b>MODELS WITH NEMA 4</b>			
NEMA 4 THERMOCOUPLE	TC1,TC2,TC3,TC4,TC5,TC6	TP2083-N4	TP2083-N4
<b>MODELS WITH INSTRUMENTATION OPTION</b>			
PRESSURE GAUGE	PI4, P5	LP1020	LP1020
TEMPERATURE GAUGE	TG1, TG2	LT3250-.25	LT3250-.25

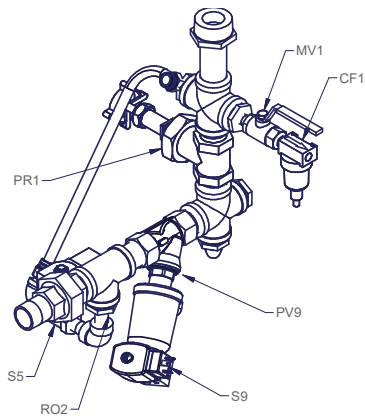
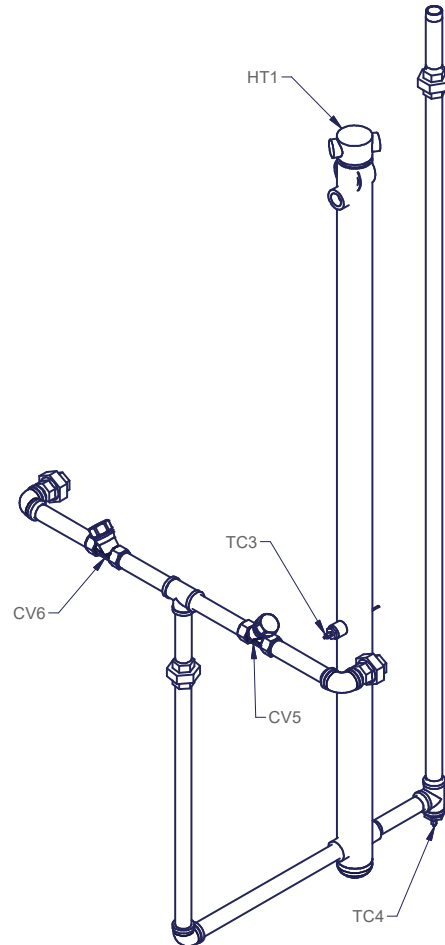
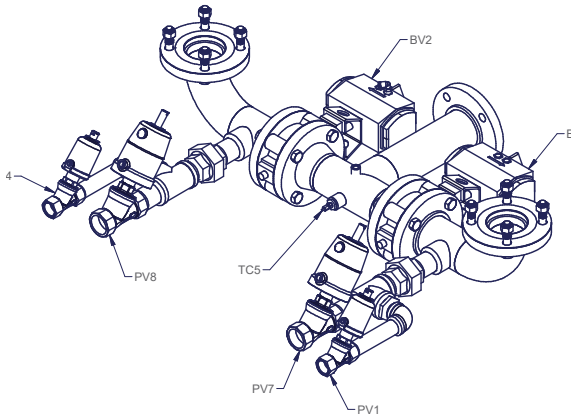
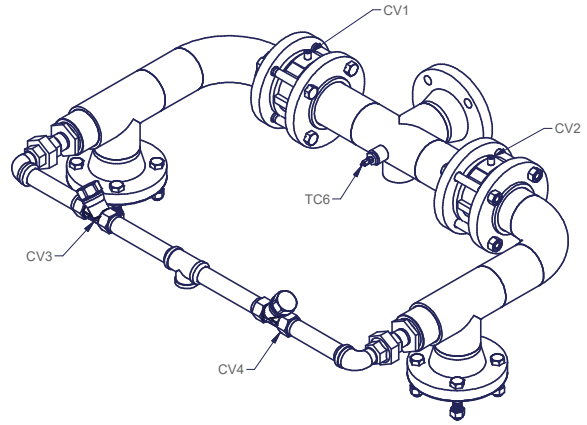
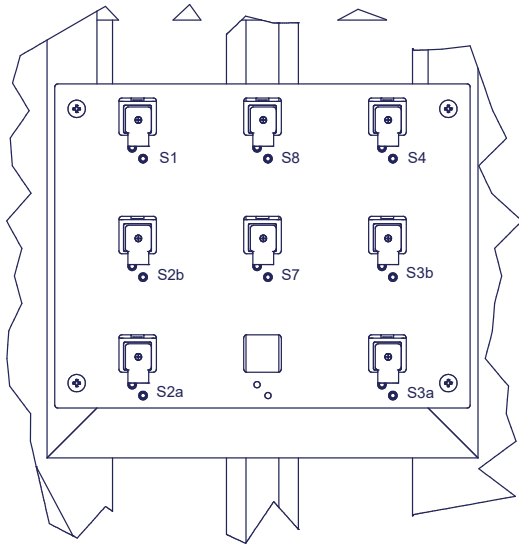

TWP1001FY41NNN-MAN REV-A

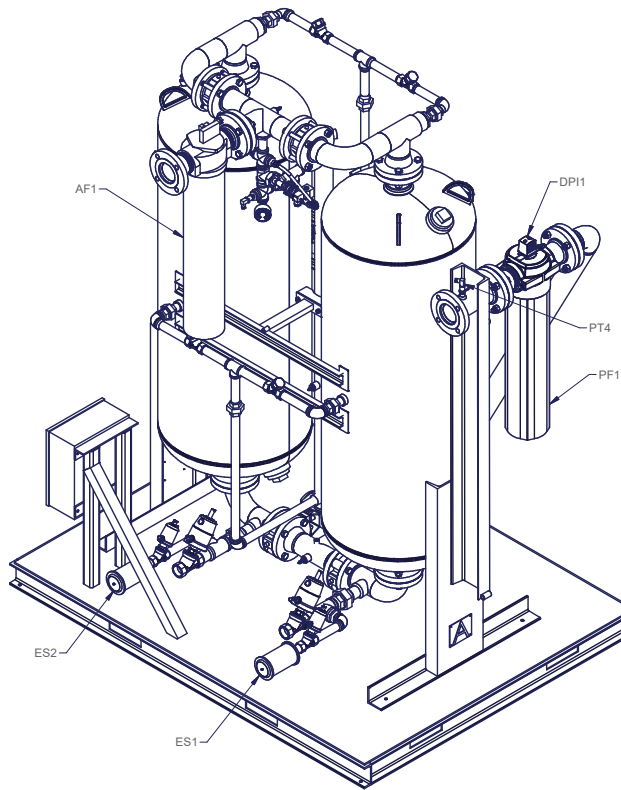
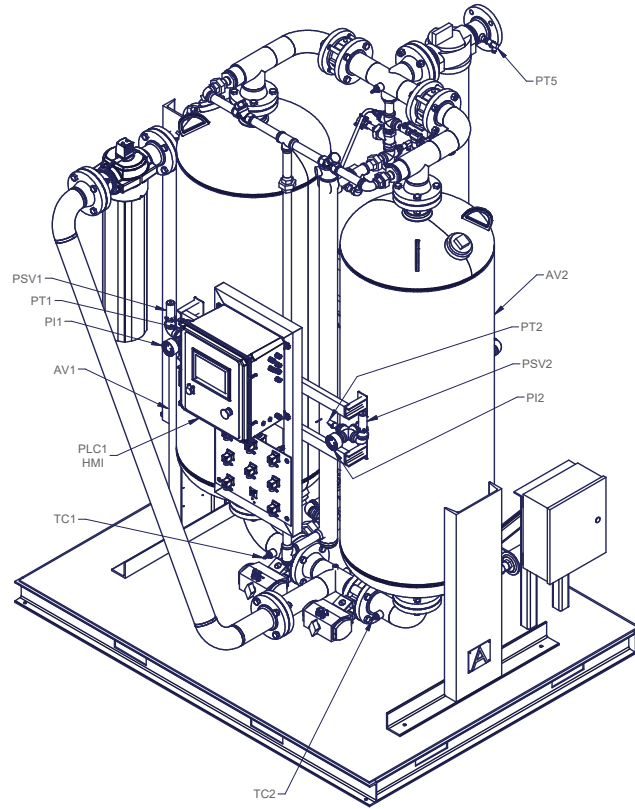

TWP1001FY41NNN-MAN REV-A



## Externally Heated Spare Parts List (Flow schematic drawing# FS11685)

	MODEL	TWP1501	TWP2001	TWP2601	TWP3001
<b>DESICCANT</b>	<b>PART ID</b>	<b>PART NUMBER</b>			
DESICCANT 25LB BAGS (QTY)	AV1, AV2	PDA-1/8-25 (88)	PDA-1/8-25 (120)	PDA-1/8-25 (160)	PDA-1/8-25 (176)
<b>FILTER ELEMENTS</b>					
COALESCER ELEMENT (QTY)	PF1, PF2	JE-C1501 (1)	JE-C2001 (1)	JE-C3001 (1)	JE-C3001 (1)
PARTICULATE ELEMENT (QTY)	AF1, AF2	JE-FC2500-HT (1)	JE-FC3320-HT (1)	JE-FC3320-HT (1)	JE-FC3320-HT (1)
CONTROL AIR FILTER ELEMENT (QTY)	CF1	TP2201-PE (1)	TP2201-PE (1)	TP2201-PE (1)	TP2201-PE (1)
<b>REPAIR KITS</b>					
INLET VALVE REPAIR KIT	PV2, PV3	TP7631-BD-HP-RK	TP7641-BD-HP-RK	TP7641-BD-HP-RK	TP7641-BD-HP-RK
INLET VALVE ACTUATOR	PV2, PV3	TP7631-BD-HP-A	TP7631-BD-HP-A	TP7631-BD-HP-A	TP7631-BD-HP-A
EXHAUST VALVE REPAIR KIT	PV1, PV4	TP7520-P1-RK	TP7520-P1-RK	TP7631-BD-HP-RK	TP7631-BD-HP-RK
EXHAUST VALVE ACTUATOR	PV1, PV4			TP7532-B-HP-A	TP7532-B-HP-A
PRE EXHAUST VALVE REPAIR KIT	PV7, PV8	TP7431-SWRK	TP7510-P1-RK	TP7510-P1-RK	TP7510-P1-RK
OUTLET CHK VALVE REPAIR KIT	CV1, CV2	TP7410-AB-RK	TP7441-SWRK	TP7441-SWRK	TP7441-SWRK
PURGE CHK VALVE REPAIR KIT	CV3, CV4, CV5, CV6	TP7410-AB-RK	TP7415-AB-RK	TP7415-AB-RK	TP7421-SWRK
REPRESS VALVE REPAIR KIT	PV5	TP7610-P1-RK	TP7610-P1-RK	TP7610-P1-RK	TP7610-P1-RK
PURGE STOP VALVE REPAIR KIT	S9	TP7615-P1-RK	TP7615-P1-RK	TP7615-P1-RK	TP7615-P1-RK
<b>REPLACEMENT PARTS</b>					
INLET VALVE	PV2, PV3	TP7631-BD-HP	TP7641-BD-HP	TP7641-BD-HP	TP7641-BD-HP
EXHAUST VALVE	P1, PV4	TP7520-P1	TP7520-P1	TP7532-B-HP	TP7532-B-HP
PRE EXHAUST VALVE	PV7, PV8	TP7510-P1	TP7510-P1	TP7510-P1	TP7510-P1
OUTLET CHECK VALVE	CV1, CV2	TP7431-SW	TP7441-SW	TP7441-SW	TP7441-SW
PURGE CHECK VALVE	CV3, CV4, CV5, CV6	TP7410-AB	TP7415-AB	TP7415-AB	TP7421-SW
REPRESS CONTROL SOLENOID VALVE	S5	TP8101-D	TP8101-D	TP8101-D	TP8101-D
REPRESS VALVE	PV5	TP7610-P1	TP7610-P1	TP7610-P1	TP7610-P1
PURGE STOP VALVE	PV9	TP7615-P1	TP7615-P1	TP7615-P1	TP7615-P1
CONTROL SOLENOID VALVE	S2A, S2B, S3A, S3B	TP8101-1D	TP8101-1D	TP8101-1D	TP8101-1D
CONTROL SOLENOID VALVE	S1, S4, S7, S8, S9	TP8101-1D	TP8101-1D	TP8101-1D	TP8101-1D
DRAIN VALVE	S10, S11	TP8002	TP8002	TP8002	TP8002
MUFFLER, EXHAUST	ES1, ES2	TP4210-1	TP4210-1	TP4210-1	TP4210-1
FILTER, CONTROL AIR	CF1	TP2201-P	TP2201-P	TP2201-P	TP2201-P
SAFETY RELIEF VALVE	PSV1, PSV2	TP7110	TP7120	TP7120	TP7120
PRESSURE GAUGE	PI1, PI2, PI3	LP1020	LP1045	LP1045	LP1045
PURGE ORIFICE	RO1	TP4443-1520	TP4463-1525	TP4463-1525	TP4475-1530
BACKUP PURGE ORIFICE	RO2	TP4137	TP4443-1020	TP4150	TP4450-1025
THERMOCOUPLE	TC1,TC2,TC3,TC4,TC5,TC6	TP2082-UNGRD	TP2082-UNGRD	TP2082-UNGRD	TP2082-UNGRD
VESSEL MANWAY GASKET	AV1, AV2		FM21216-G	FM21216-G	FM21216-G
HEATER	HT1	TP3618-4	TP3625-4	TP3625-4	TP3630-4-60
PRESSURE TRANSDUCER	PT1,PT2,PT3,PT4,PT5	TP2451	TP2451	TP2451	TP2451
CONTACTOR	C1, C2	ES5050	ES5050	ES5075	ES5075
PLC	PLC1	TP2681-PLC-P1500	TP2681-PLC-P1500	TP2681-PLC-P1500	TP2681-PLC-P1500
HMI DISPLAY	HMI	TP2681-HMI-P1500	TP2681-HMI-P1500	TP2681-HMI-P1500	TP2681-HMI-P1500
POWER SUPPLY		2080-PS120-240V	2080-PS120-240V	2080-PS120-240V	2080-PS120-240V
FUSE, 1 AMP	F1	EF0100-2-TD	EF0100-2-TD	EF0100-2-TD	EF0100-2-TD
FUSE, 2 AMP	F2	EF0200-2-TD	EF0200-2-TD	EF0200-2-TD	EF0200-2-TD
FUSE, 1/4 AMP	F3	EF0025-TD	EF0025-TD	EF0025-TD	EF0025-TD
MEMORY CARD		TP2681-MEM	TP2681-MEM	TP2681-MEM	TP2681-MEM
DEWPOINT PROBE	AE1	TP2190-1-UL	TP2190-1-UL	TP2190-1-UL	TP2190-1-UL
<b>MODELS WITH NEMA 4</b>					
NEMA 4 THERMOCOUPLE	TC1,TC2,TC3,TC4,TC5,TC6	TP2083-N4	TP2083-N4-12	TP2083-N4-12	TP2083-N4-12
<b>MODELS WITH INSTRUMENTATION OPTION</b>					
PRESSURE GAUGE	PI4, P5	LP1020	LP1045	LP1045	LP1045
TEMPERATURE GAUGE	TG1, TG2	LT3250-25	LT3250-25	LT3250-25	LT3250-25

**Externally Heated Spare Parts List (Flow schematic drawing# FS11685)**

MODEL	TWP4001	TWP5001	TWP6001	TWP7501	
<b>DESICCANT</b>	<b>PART ID</b>	<b>PART NUMBER</b>			
DESICCANT 25LB BAGS (QTY)	AV1, AV2	PDA-1/8-25 (232)	PDA-1/8-25 (288)	PDA-1/8-25 (352)	PDA-1/8-25 (456)
<b>FILTER ELEMENTS</b>					
COALESCER ELEMENT (QTY)	PF1, PF2	JE-C1501 (3)	JE-C1501 (4)	JE-C1501 (4)	JE-C1501 (7)
PARTICULATE ELEMENT (QTY)	AF1, AF2	JE-FC4000-HT (1)	JE-FC4000-HT (1)	JE-FC2500-HT (3)	JE-FC2500-HT (4)
CONTROL AIR FILTER ELEMENT (QTY)	CF1	TP2201-PE (1)	TP2201-PE (1)	TP2201-PE (1)	TP2201-PE (1)
<b>REPAIR KITS</b>					
INLET VALVE REPAIR KIT	PV2, PV3	TP7661-BD-HP-RK	TP7661-BD-HP-RK	TP7661-BD-HP-RK	TP7681-BD-HP-RK
INLET VALVE ACTUATOR	PV2, PV3	TP7631-BD-HP-A	TP7631-BD-HP-A	TP7631-BD-HP-A	TP7681-BD-HP-A
EXHAUST VALVE REPAIR KIT	PV1, PV4	TP7631-BD-HP-RK	TP7641-BD-HP-RK	TP7641-BD-HP-RK	TP7641-BD-HP-RK
EXHAUST VALVE ACTUATOR	PV1, PV4	TP7532-B-HP-A	TP7542-B-HP-A	TP7542-B-HP-A	TP7542-B-HP-A
PRE EXHAUST VALVE REPAIR KIT	PV7, PV8	TP7515-P1-RK	TP7520-P1-RK	TP7520-P1-RK	TP7520-P1-RK
OUTLET CHK VALVE REPAIR KIT	CV1, CV2	TP7461-SWRK	TP7461-SWRK	TP7461-SWRK	TP7481-SWRK
PURGE CHK VALVE REPAIR KIT	CV3, CV4	TP7431-SWRK	TP7431-SWRK	TP7431-SWRK	TP7441-SWRK
PURGE CHK VALVE REPAIR KIT	CV5, CV6	TP7420-AB-RK	TP7420-AB-RK	TP7420-AB-RK	TP7420-AB-RK
REPRESS VALVE REPAIR KIT	PV5	TP7610-P1-RK	TP7615-P1-RK	TP7615-P1-RK	TP7615-P1-RK
PURGE STOP VALVE REPAIR KIT	S9	TP7615-P1-RK	TP7620-P1-RK	TP7620-P1-RK	TP7620-P1-RK
<b>REPLACEMENT PARTS</b>					
INLET VALVE	PV2, PV3	TP7661-BD-HP	TP7661-BD-HP	TP7661-BD-HP	TP7681-BD-HP
EXHAUST VALVE	P1, PV4	TP7532-B-HP	TP7542-B-HP	TP7542-B-HP	TP7542-B-HP
PRE EXHAUST VALVE	PV7, PV8	TP7515-P1	TP7520-P1	TP7520-P1	TP7520-P1
OUTLET CHECK VALVE	CV1, CV2	TP7461-SW	TP7461-SW	TP7461-SW	TP7481-SW
PURGE CHECK VALVE	CV3, CV4	TP7431-SW	TP7431-SW	TP7431-SW	TP7441-SW
PURGE CHECK VALVE	CV5, CV6	TP7420-AB	TP7420-AB	TP7420-AB	TP7420-AB
REPRESS CONTROL SOLENOID VALVE	S5	TP8101-D	TP8101-D	TP8101-D	TP8101-D
REPRESS VALVE	PV5	TP7610-P1	TP7615-P1	TP7615-P1	TP7615-P1
PURGE STOP VALVE	PV9	TP7615-P1	TP7620-P1	TP7620-P1	TP7620-P1
CONTROL SOLENOID VALVE	S2A, S2B, S3A, S3B	TP8101-1D	TP8101-1D	TP8101-1D	TP8101-1D
CONTROL SOLENOID VALVE	S1, S4, S7, S8, S9	TP8101-1D	TP8101-1D	TP8101-1D	TP8101-1D
DRAIN VALVE	S10, S11	TP8003	TP8003	TP8003	TP8003
MUFFLER, EXHAUST	ES1, ES2	TP4215-1	TP4220-1	TP4220-1	TP4220-1
FILTER, CONTROL AIR	CF1	TP2201-P	TP2201-P	TP2201-P	TP2201-P
SAFETY RELIEF VALVE	PSV1, PSV2, PSV3, PSV4	TP7120	TP7120	TP7120	TP7120
PRESSURE GAUGE	PI1, PI2	LP1045	LP1045	LP1045	LP1045
PRESSURE GAUGE	PI3	LP1020	LP1020	LP1020	LP1020
PURGE ORIFICE	RO1	TP4475-1530	TP4499-2030-F	TP4499-2030-F	TP4499-2030-F
BACKUP PURGE ORIFICE	RO2	TP4156	TP4463-1525	TP4468-1525	TP4478
THERMOCOUPLE	TC1,TC2,TC3,TC4,TC5,TC6	TP2082-UNGRD	TP2082-UNGRD	TP2082-UNGRD	TP2082-UNGRD
VESSEL MANWAY GASKET	AV1, AV2	FM21216-G	FM21216-G	FM21216-G	FM21216-G
HEATER	HT1	TP3650-4	TP3650-4	TP3660-4	TP3685-4
PRESSURE TRANSDUCER	PT1,PT2,PT3,PT4,PT5	TP2451	TP2451	TP2451	TP2451
FUSE, HEATER		EF3040-F	EF3040-F	EF3050-F	EF3045-F
CONTACTOR	C1,C2,C3,C4,C5,C6,C7,C8	ES5075	ES5075	ES5075	ES5075
PLC	PLC1	TP2681-PLC-P1500	TP2681-PLC-P1500	TP2681-PLC-P1500	TP2681-PLC-P1500
HMI DISPLAY	HMI	TP2681-HMI-P1500	TP2681-HMI-P1500	TP2681-HMI-P1500	TP2681-HMI-P1500
POWER SUPPLY		2080-PS120-240V	2080-PS120-240V	2080-PS120-240V	2080-PS120-240V
FUSE, 1 AMP	F1	EF0100-2-TD	EF0100-2-TD	EF0100-2-TD	EF0100-2-TD
FUSE, 2 AMP	F2	EF0200-2-TD	EF0200-2-TD	EF0200-2-TD	EF0200-2-TD
FUSE, 1/4 AMP	F3	EF0025-TD	EF0025-TD	EF0025-TD	EF0025-TD
MEMORY CARD		TP2681-MEM	TP2681-MEM	TP2681-MEM	TP2681-MEM
DEWPOINT PROBE	AE1	TP2190-1-UL	TP2190-1-UL	TP2190-1-UL	TP2190-1-UL
<b>MODELS WITH NEMA 4</b>					
NEMA 4 THERMOCOUPLE	TC1,TC2,TC3,TC4,TC5,TC6	TP2083-N4-12	TP2083-N4-12	TP2083-N4-12	TP2083-N4-12
<b>MODELS WITH INSTRUMENTATION OPTION</b>					
PRESSURE GAUGE	PI4, P5	LP1045	LP1045	LP1045	LP1045
TEMPERATURE GAUGE	TG1, TG2	LT3250-.25	LT3250-.25	LT3250-.25	LT3250-.25

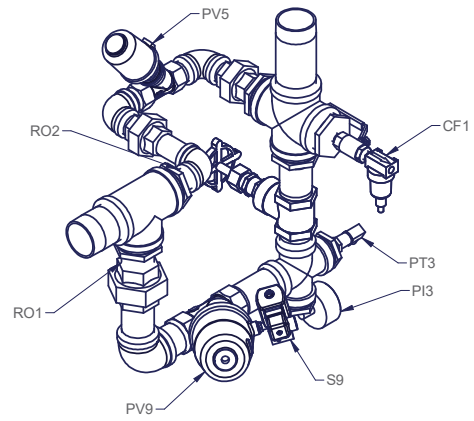
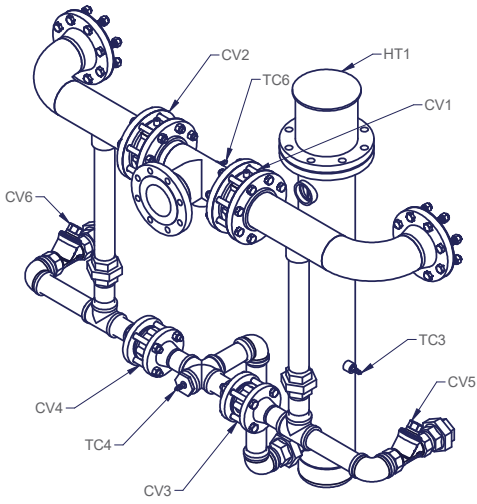
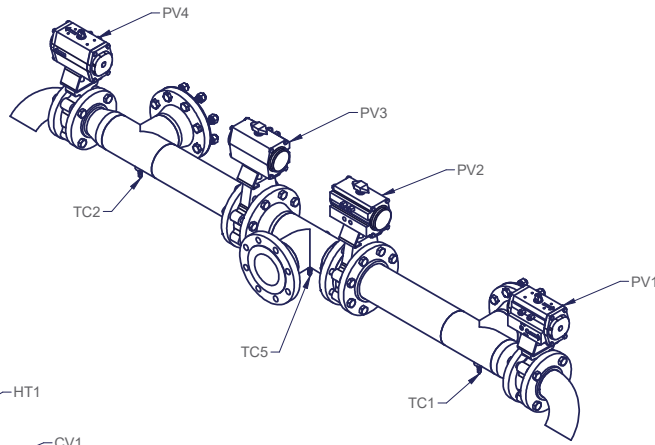
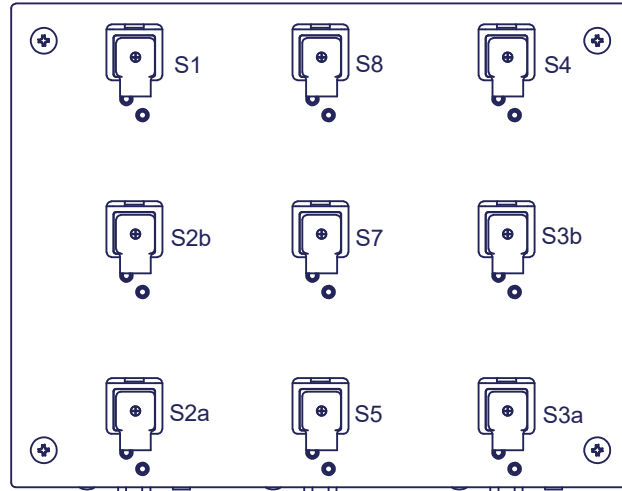

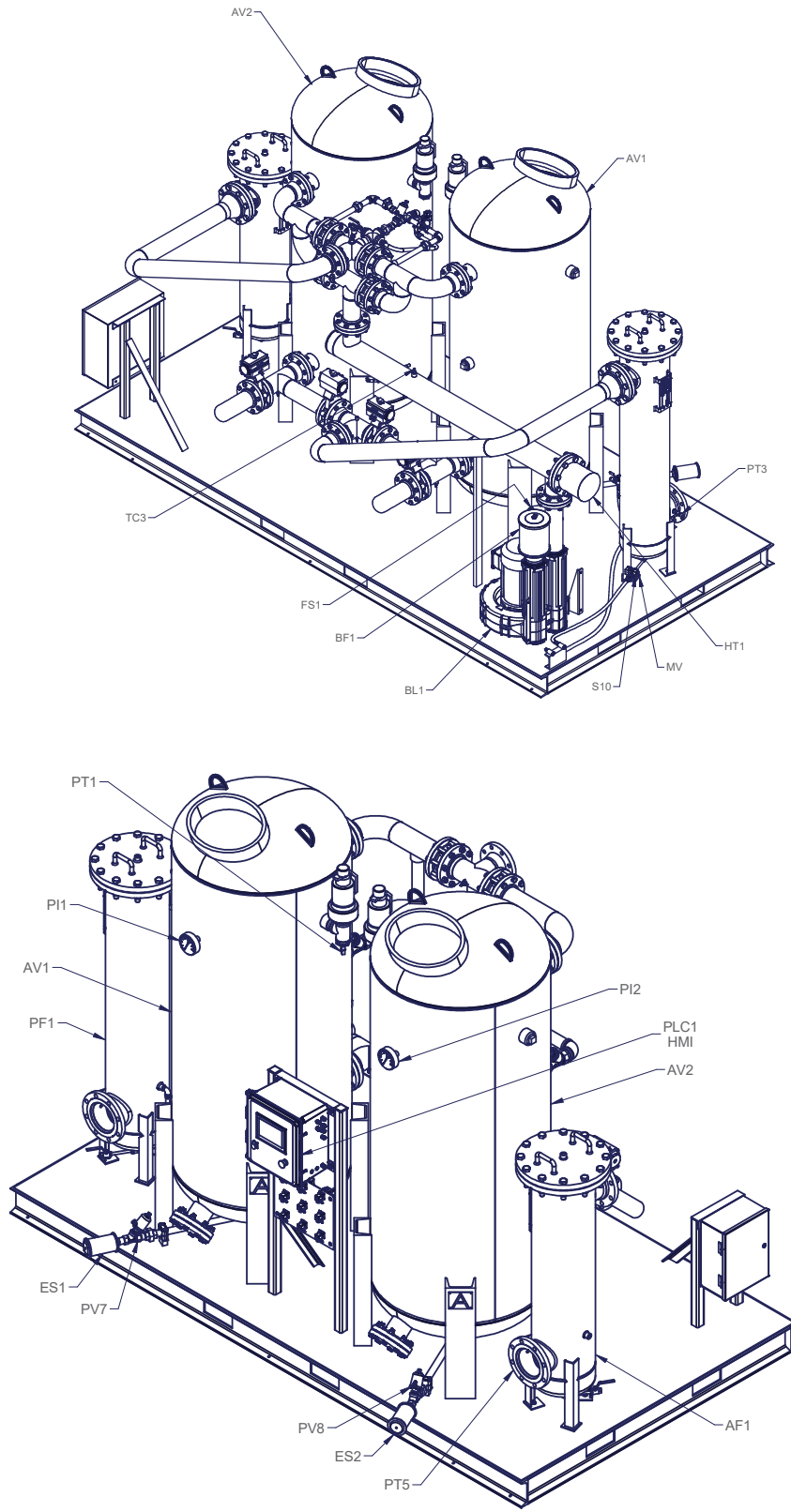

TWP3001FY41NNN-MAN REV-

**Blower Purge Spare Parts List (Flow schematic drawing# FS11686)**

	MODEL	TWB201	TWB301	TWB401	TWB501	TWB601	TWB801
<b>DESICCANT</b>	<b>PART ID</b>	<b>PART NUMBER</b>					
DESICCANT 25LB BAGS (QTY)	AV1, AV2	PDA-1/8-25 (12)	PDA-1/8-25 (20)	PDA-1/8-25 (24)	PDA-1/8-25 (30)	PDA-1/8-25 (36)	PDA-1/8-25 (48)
<b>FILTER ELEMENTS</b>							
COALESCER ELEMENT (QTY)	PF1, PF2	P030AA (1)	P035AA (1)	P040AA (1)	P045AA (1)	P045AA (1)	P050AA (1)
PARTICULATE ELEMENT (QTY)	AF1, AF2	JE-FC0350-HT (1)	JE-FC0350-HT (1)	JE-FC0450-HT (1)	JE-FC0625-HT (1)	JE-FC0625-HT (1)	JE-FC0800-HT (1)
CONTROL AIR FILTER ELEMENT (QTY)	CF1	TP2201-PE (1)	TP2201-PE (1)	TP2201-PE (1)	TP2201-PE (1)	TP2201-PE (1)	TP2201-PE (1)
BLOWER INTAKE ELEMENT	BF1	TP1415-E	TP1415-E	TP1415-E	TP1420-E	TP1420-E	TP1420-E
<b>REPAIR KITS</b>							
INLET VALVE REPAIR KIT	PV2, PV3	TP7615-P1-RK	TP7615-P1-RK	TP7620-P1-RK	TP7620-P1-RK	TP7620-P1-RK	TP7620-P1-RK
EXHAUST VALVE REPAIR KIT	PV1, PV4	TP7515-P1-RK	TP7515-P1-RK	TP7515-P1-RK	TP7520-P1-RK	TP7520-P1-RK	TP7520-P1-RK
OUTLET CHK VALVE REPAIR KIT	CV1	TP7415-SDX-RK	TP7415-SDX-RK	TP7420-SDX-RK	TP7420-SDX-RK	TP7420-SDX-RK	TP7420-SDX-RK
PURGE CHK VALVE REPAIR KIT	CV3, CV4, CV5	TP7415-AB-RK	TP7415-AB-RK	TP7415-AB-RK	TP7420-AB-RK	TP7420-AB-RK	TP7420-AB-RK
<b>REPLACEMENT PARTS</b>							
INLET VALVE	PV2, PV3	TP7615-P1	TP7615-P1	TP7620-P1	TP7620-P1	TP7620-P1	TP7620-P1
EXHAUST VALVE	P1, PV4	TP7515-P1	TP7515-P1	TP7515-P1	TP7520-P1	TP7520-P1	TP7520-P1
OUTLET CHECK VALVE	CV1	TP7415-SDX	TP7415-SDX	TP7420-SDX	TP7420-SDX	TP7420-SDX	TP7420-SDX
PURGE CHECK VALVE	CV3, CV4, CV5	TP7415-AB-0	TP7415-AB-0	TP7415-AB-0	TP7420-AB-0	TP7420-AB-0	TP7420-AB-0
2% COOLING VALVE	S6	TP8003	TP8003	TP8003	TP8003	TP8003	TP8003
REPRESSURIZATION VALVE	S5	TP8003	TP8003	TP8003	TP8003	TP8005	TP8005
CONTROL SOLENOID VALVE	S1, S2B, S3B, S4	TP8101-1D	TP8101-1D	TP8101-1D	TP8101-1D	TP8101-1D	TP8101-1D
DRAIN VALVE	FD1, FD2	PD15NO	PD15NO	PD15NO	PD15NO	PD15NO	PD15NO
MUFFLER, EXHAUST	ES1, ES2	TP4215-1	TP4215-1	TP4215-1	TP4220-1	TP4220-1	TP4230-1
FILTER, CONTROL AIR	CF1	TP2201-P	TP2201-P	TP2201-P	TP2201-P	TP2201-P	TP2201-P
SAFETY RELIEF VALVE	PSV1, PSV2	TP7105	TP7105	TP7105	TP7105	TP7105	TP7110
PRESSURE GAUGE	PI1, PI2, PI3	LP1020	LP1020	LP1020	LP1020	LP1020	LP1020
ORIFICE 2% COOLING	RO1	TP4312	TP4318	TP4318	TP4322	TP4322	TP4325
BACKUP PURGE ORIFICE	RO2	TP4118	TP4122	TP4125	TP4128	TP4431-0515	TP4137-0520
FILTER DP GAUGE	DPI1, DPI2	ZD90GL	ZD90GL	ZD90GL	ZD90GL	ZD90GL	ZD90GL
THERMOCOUPLE	TC1, TC2, TC3, TC4, TC5, TC6	TP2082-UNGRD	TP2082-UNGRD	TP2082-UNGRD	TP2082-UNGRD	TP2082-UNGRD	TP2082-UNGRD
HEATER	HT1	TP3606	TP3606	TP3609	TP3612	TP3612	TP3615
BLOWER	BL1	TP1710-4	TP1720-1	TP1730-4	TP1740-4	TP1740-4	TP1752
PRESSURE TRANSDUCER	PT1, PT2, PT3, PT4	TP2451	TP2451	TP2451	TP2451	TP2451	TP2451
FLOW SWITCH	FS1	DP6010	DP6010	DP6010	DP6010	DP6010	DP6010
HEATER CONTACTOR	C1, C2	ES5050	ES5050	ES5050	ES5050	ES5050	ES5050
BLOWER CONTACTOR	MS1	ES5003-5AF	ES5003-5AF	ES5003-5AF	ES5003-5AF	ES5003-5AF	ES5003-5AF
STARTER OVERLOAD	OL	ES5001-TF-2.3	ES5001-TF-4.2	ES5001-TF-5.7	ES5001-TF-7.6	ES5001-TF-7.6	ES5001-TF-10.0
HEATER FUSE		EF1500	EF1500	EF1500	EF2000	EF2000	EF2500
BLOWER FUSE		EF3002.5	EF3005	EF3006	EF3008	EF3008	EF3015
PLC	PLC1	TP2681-PLC-B800	TP2681-PLC-B800	TP2681-PLC-B800	TP2681-PLC-B800	TP2681-PLC-B800	TP2681-PLC-B800
HMI DISPLAY	HMI	TP2681-HMI-B800	TP2681-HMI-B800	TP2681-HMI-B800	TP2681-HMI-B800	TP2681-HMI-B800	TP2681-HMI-B800
POWER SUPPLY		2080-PS120-240V	2080-PS120-240V	2080-PS120-240V	2080-PS120-240V	2080-PS120-240V	2080-PS120-240V
FUSE, 1 AMP	F1	EF0100-2-TD	EF0100-2-TD	EF0100-2-TD	EF0100-2-TD	EF0100-2-TD	EF0100-2-TD
FUSE, 2 AMP	F2	EF0200-2-TD	EF0200-2-TD	EF0200-2-TD	EF0200-2-TD	EF0200-2-TD	EF0200-2-TD
FUSE, 1/4 AMP	F3	EF0025-TD	EF0025-TD	EF0025-TD	EF0025-TD	EF0025-TD	EF0025-TD
MEMORY CARD		TP2681-MEM	TP2681-MEM	TP2681-MEM	TP2681-MEM	TP2681-MEM	TP2681-MEM
DEWPOINT PROBE	AE1	TP2190-1-UL	TP2190-1-UL	TP2190-1-UL	TP2190-1-UL	TP2190-1-UL	TP2190-1-UL
<b>MODELS WITH NEMA 4</b>							
NEMA 4 THERMOCOUPLE	TC1, TC2, TC3, TC4, TC5, TC6	TP2083-N4	TP2083-N4	TP2083-N4	TP2083-N4	TP2083-N4	TP2083-N4
<b>MODELS WITH OUTDOOR PACKAGE</b>							
BLOWER INTAKE ELEMENT	BF1						
<b>MODELS WITH INSTRUMENTATION OPTION</b>							
PRESSURE GAUGE	PI4, P5	LP1020	LP1020	LP1020	LP1020	LP1020	LP1020
TEMPERATURE GAUGE	TG1, TG2	LT3250-.25	LT3250-.25	LT3250-.25	LT3250-.25	LT3250-.25	LT3250-.25

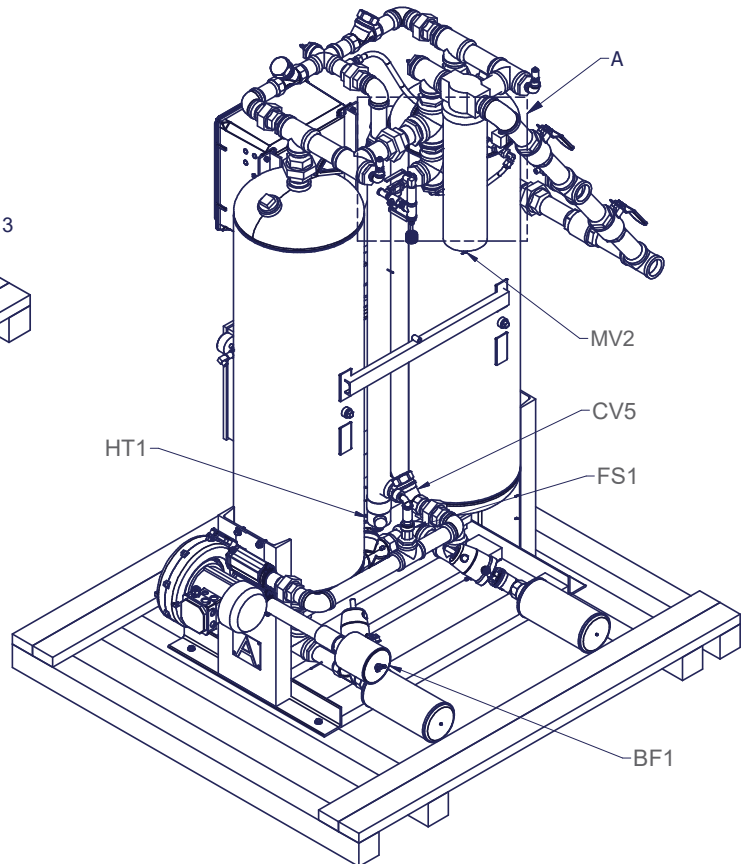
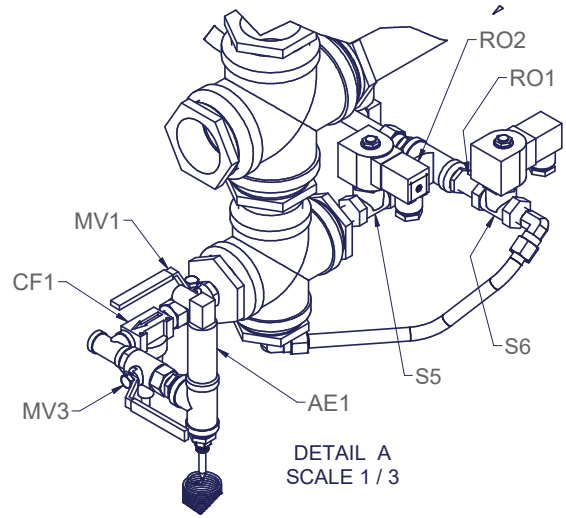
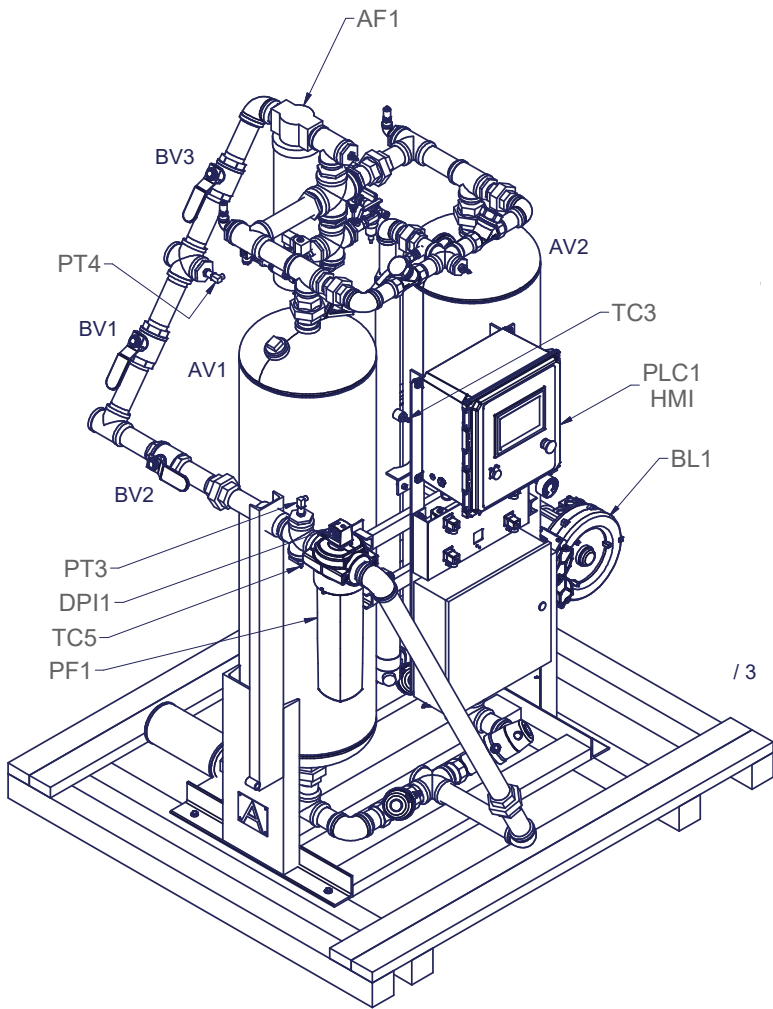

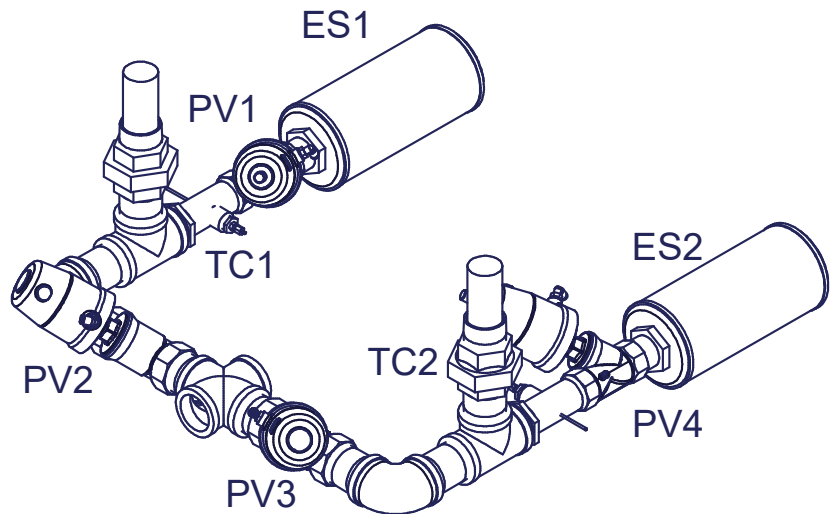
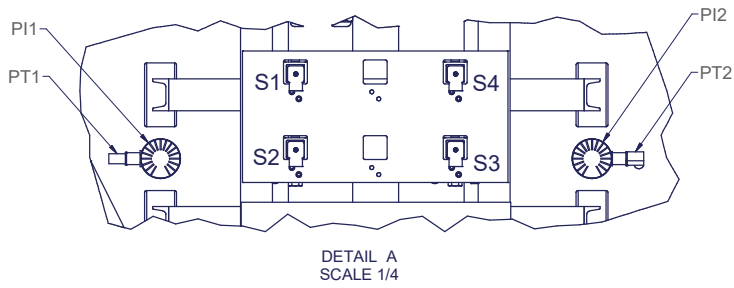
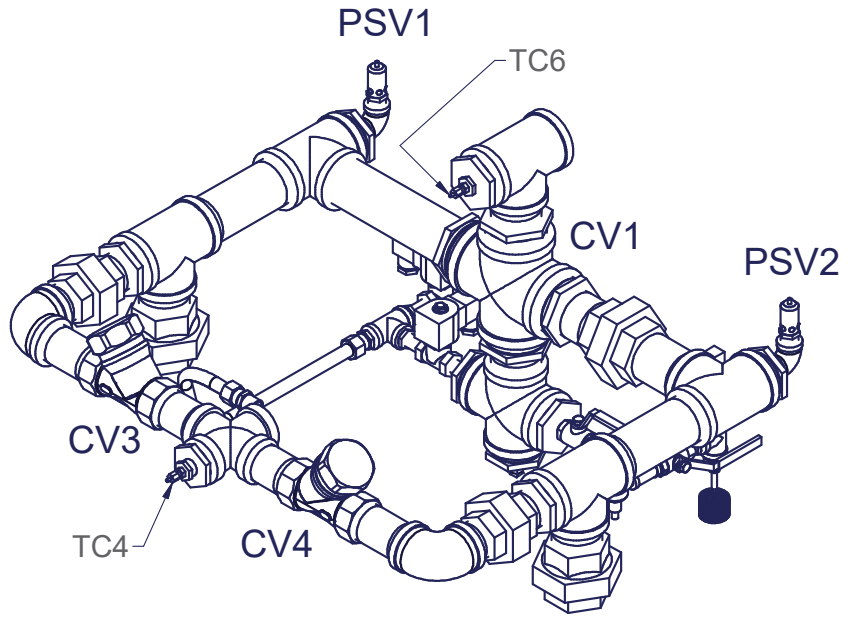

## Blower Purge Spare Parts List (Flow schematic drawing# FS11687)

	MODEL	TWB1001	TWB1201
<b>DESICCANT</b>	<b>PART ID</b>	<b>PART NUMBER</b>	
DESICCANT 25LB BAGS (QTY)	AV1, AV2	PDA-1/8-25 (60)	PDA-1/8-25 (70)
<b>FILTER ELEMENTS</b>			
COALESCER ELEMENT (QTY)	PF1, PF2	P055AA (1)	P055AA (1)
PARTICULATE ELEMENT (QTY)	AF1, AF2	JE-FC1330-HT (1)	JE-FC1330-HT (1)
CONTROL AIR FILTER ELEMENT (QTY)	CF1	TP2201-PE (1)	TP2201-PE (1)
BLOWER INTAKE ELEMENT	BF1	TP1420-E	TP1430-E
<b>REPAIR KITS</b>			
INLET VALVE REPAIR KIT	PV2, PV3	TP7631-BD-HP-RK	TP7631-BD-HP-RK
INLET VALVE ACTUATOR	PV2, PV3	TP7631-BD-HP-A	TP7631-BD-HP-A
EXHAUST VALVE REPAIR KIT	PV1, PV4	TP7520-P1-RK	TP7631-BD-HP-RK
EXHAUST VALVE ACTUATOR	PV1, PV4		TP7532-B-HP-A
PRE EXHAUST VALVE REPAIR KIT	PV7, PV8	TP7510-P1-RK	TP7510-P1-RK
OUTLET CHK VALVE REPAIR KIT	CV1, CV2	TP7431-SWRK	TP7431-SWRK
PURGE CHK VALVE REPAIR KIT	CV3, CV4, CV5	TP7420-AB-RK	TP7431-SWRK
<b>REPLACEMENT PARTS</b>			
INLET VALVE	PV2, PV3	TP7631-BD-HP	TP7631-BD-HP
EXHAUST VALVE	P1, PV4	TP7520-P1	TP7532-B-HP
PRE EXHAUST VALVE	PV7, PV8	TP7510-P1	TP7510-P1
OUTLET CHECK VALVE	CV1, CV2	TP7431-SW	TP7431-SW
PURGE CHECK VALVE	CV3, CV4, CV5	TP7420-AB-0	TP7431-SW
2% COOLING VALVE	S6	TP8005	TP8005
REPRESS CONTROL VALVE	S5	73218BN5VN00NOD100P3	73218BN5VN00NOD100P3
CONTROL SOLENOID VALVE	S2A, S2B, S3A, S3B	TP8101-1D	TP8101-1D
CONTROL SOLENOID VALVE	S1, S4, S7, S8	TP8101-1D	TP8101-1D
DRAIN VALVE	FD1, FD2	PD15NO	PD15NO
MUFFLER, EXHAUST	ES1, ES2	TP4210-1	TP4210-1
FILTER, CONTROL AIR	CF1	TP2201-P	TP2201-P
SAFETY RELIEF VALVE	PSV1, PSV2	TP7110	TP7110
PRESSURE GAUGE	PI1, PI2	LP1020	LP1020
ORIFICE 2% COOLING	RO1	TP4331	TP4331
BACKUP PURGE ORIFICE	RO2	TP4143	TP4143
FILTER DP GAUGE	DPI1, DPI2	ZD90GL	ZD90GL
THERMOCOUPLE	TC1,TC2,TC3,TC4,TC5,TC6	TP2082-UNGRD	TP2082-UNGRD
HEATER	HT1	TP3618-4	TP3625-4
BLOWER	BL1	TP1752	TP1740-5.5
PRESSURE TRANSDUCER	PT1, PT2, PT3, PT4	TP2451	TP2451
FLOW SWITCH	FS1	DP6010	DP6010
HEATER CONTACTOR	C1, C2	ES5050	ES5075
BLOWER CONTACTOR	MS1	ES5003-5AF	ES5003-5AF
STARTER OVERLOAD	OL	ES5001-TF-10.0	ES5001-TF-10.0
HEATER FUSE		EF3000	EF3040-F
BLOWER FUSE		EF3015	EF3015
PLC	PLC1	TP2681-PLC-B1200	TP2681-PLC-B1200
HMI DISPLAY	HMI	TP2681-HMI-B1200	TP2681-HMI-B1200
POWER SUPPLY		2080-PS120-240V	2080-PS120-240V
FUSE, 1 AMP	F1	EF0100-2-TD	EF0100-2-TD
FUSE, 2 AMP	F2	EF0200-2-TD	EF0200-2-TD
FUSE, 1/4 AMP	F3	EF0025-TD	EF0025-TD
MEMORY CARD		TP2681-MEM	TP2681-MEM
DEWPOINT PROBE	AE1	TP2190-1-UL	TP2190-1-UL
<b>MODELS WITH NEMA 4</b>			
NEMA 4 THERMOCOUPLE	TC1,TC2,TC3,TC4,TC5,TC6	TP2083-N4	TP2083-N4
<b>MODELS WITH OUTDOOR PACKAGE</b>			
BLOWER INTAKE ELEMENT	BF1		
<b>MODELS WITH INSTRUMENTATION OPTION</b>			
PRESSURE GAUGE	PI4, P5	LP1020	LP1020
TEMPERATURE GAUGE	TG1, TG2	LT3250-.25	LT3250-.25



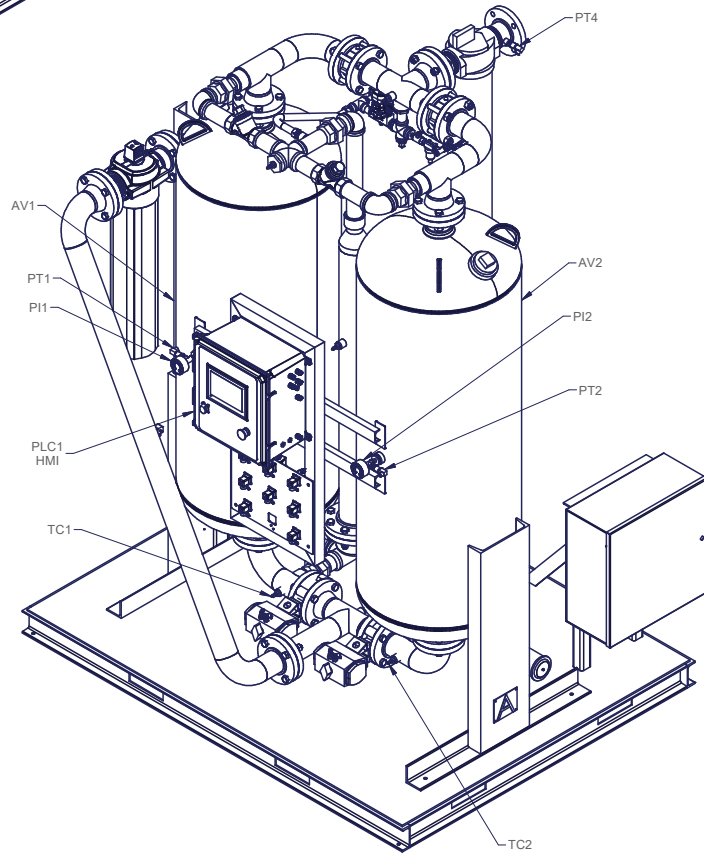
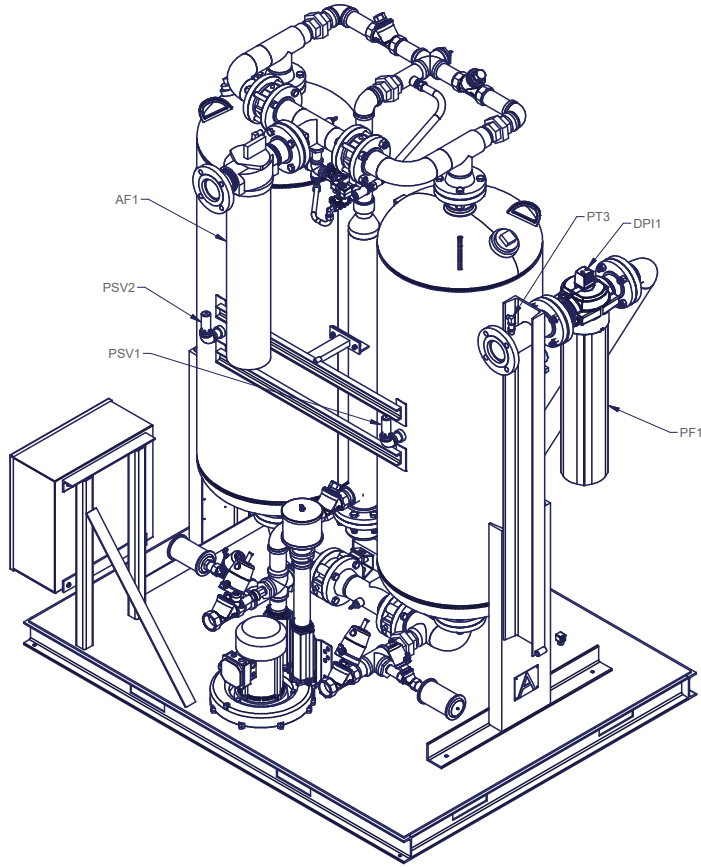

TWB1001FY41NNN-MAN REV-

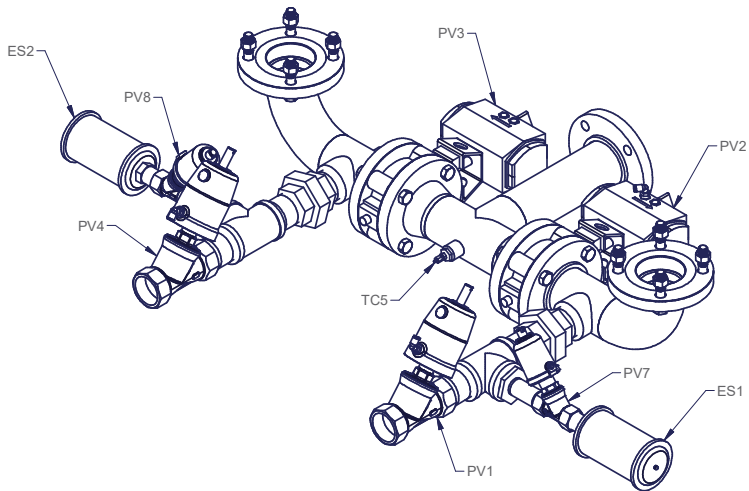
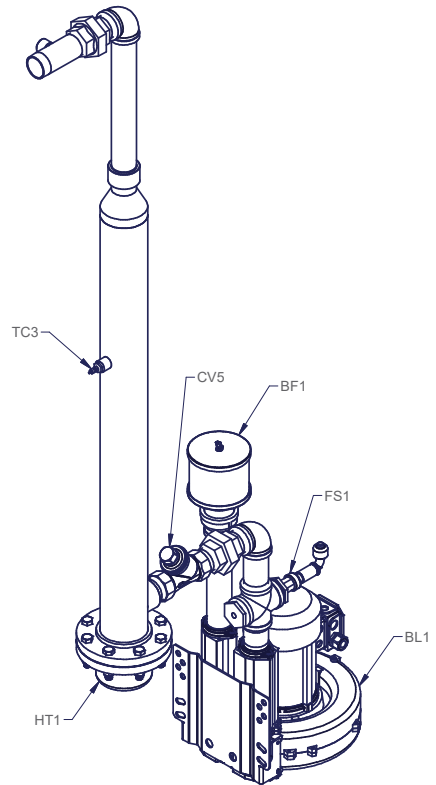
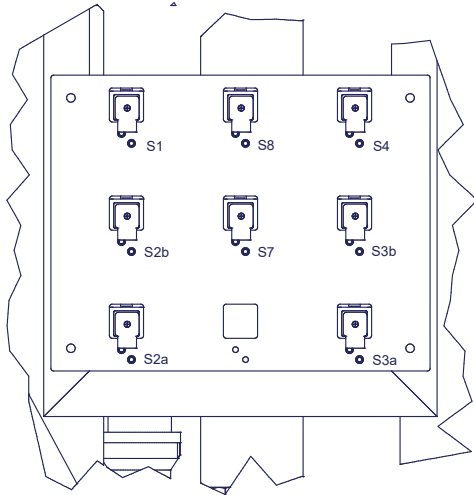
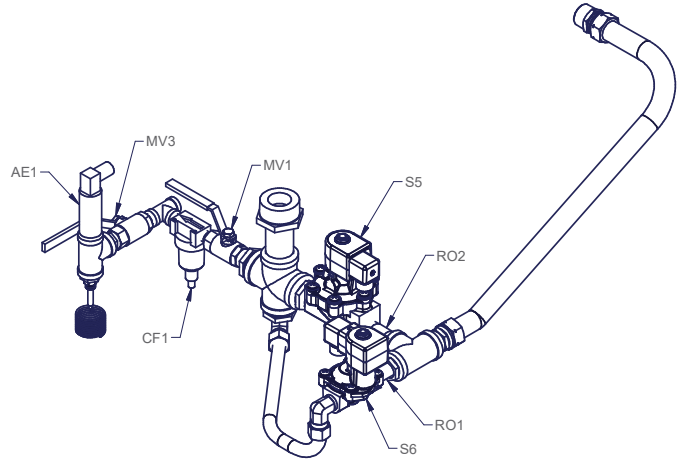
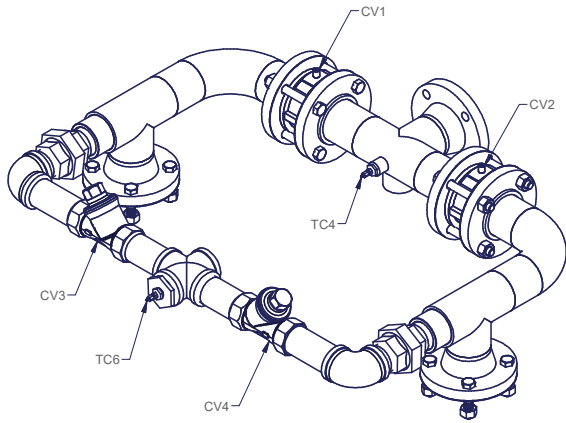

TWB1001FY41NNN-MAN REV-

## Blower Purge Spare Parts List (Flow schematic drawing# FS11688)

	MODEL	TWB1501	TWB2001	TWB2601	TWB3001
DESICCANT	PART ID	PART NUMBER			
DESICCANT 25LB BAGS (QTY)	AV1, AV2	PDA-1/8-25 (88)	PDA-1/8-25 (120)	PDA-1/8-25 (160)	PDA-1/8-25 (176)
<b>FILTER ELEMENTS</b>					
COALESCER ELEMENT (QTY)	PF1, PF2	JE-C1501 (1)	JE-C2001 (1)	JE-C3001 (1)	JE-C3001 (1)
PARTICULATE ELEMENT (QTY)	AF1, AF2	JE-FC2500-HT (1)	JE-FC3320-HT (1)	JE-FC3320-HT (1)	JE-FC3320-HT (1)
CONTROL AIR FILTER ELEMENT (QTY)	CF1	TP2201-PE (1)	TP2201-PE (1)	TP2201-PE (1)	TP2201-PE (1)
BLOWER INTAKE ELEMENT	BF1	TP1430-E	TP1430-E	TP1440-E	TP1440-E
<b>REPAIR KITS</b>					
INLET VALVE REPAIR KIT	PV2, PV3	TP7631-BD-HP-RK	TP7641-BD-HP-RK	TP7641-BD-HP-RK	TP7641-BD-HP-RK
INLET VALVE ACTUATOR	PV2, PV3	TP7631-BD-HP-A	TP7631-BD-HP-A	TP7631-BD-HP-A	TP7631-BD-HP-A
EXHAUST VALVE REPAIR KIT	PV1, PV4	TP7631-BD-HP-RK	TP7631-BD-HP-RK	TP7641-BD-HP-RK	TP7641-BD-HP-RK
EXHAUST VALVE ACTUATOR	PV1, PV4	TP7532-B-HP-A	TP7532-B-HP-A	TP7542-B-HP-A	TP7542-B-HP-A
PRE EXHAUST VALVE REPAIR KIT	PV7, PV8	TP7510-P1-RK	TP7510-P1-RK	TP7510-P1-RK	TP7510-P1-RK
OUTLET CHK VALVE REPAIR KIT	CV1, CV2	TP7431-SWRK	TP7441-SWRK	TP7441-SWRK	TP7441-SWRK
PURGE CHK VALVE REPAIR KIT	CV3, CV4	TP7431-SWRK	TP7431-SWRK	TP7441-SWRK	TP7441-SWRK
2% CHK VALVE REPAIR KIT	CV5, CV6	TP7431-SWRK	TP7410-AB-RK	TP7410-AB-RK	TP7410-AB-RK
REPRESS VALVE REPAIR KIT	PV5		TP7610-P1-RK	TP7610-P1-RK	TP7610-P1-RK
<b>REPLACEMENT PARTS</b>					
INLET VALVE	PV2, PV3	TP7631-BD-HP	TP7641-BD-HP	TP7641-BD-HP	TP7641-BD-HP
EXHAUST VALVE	P1, PV4	TP7532-B-HP	TP7532-B-HP	TP7542-B-HP	TP7542-B-HP
PRE EXHAUST VALVE	PV7, PV8	TP7510-P1	TP7510-P1	TP7510-P1	TP7510-P1
OUTLET CHECK VALVE	CV1, CV2	TP7431-SW	TP7441-SW	TP7441-SW	TP7441-SW
PURGE CHECK VALVE	CV3, CV4	TP7431-SW	TP7431-SW	TP7441-SW	TP7441-SW
2% CHECK VALVE	CV5, CV6	TP7431-SW	TP7410-AB	TP7410-AB	TP7410-AB
2% COOLING VALVE	S6	TP8005	73218BN5VN00NOD100P3	73218BN5VN00NOD100P3	73218BN5VN00NOD100P3
REPRESS CONTROL VALVE	S5	73218BN5VN00NOD100P3	TP8101-D	TP8101-D	TP8101-D
REPRESSURIZATION VALVE	PV5		TP7610-P1	TP7610-P1	TP7610-P1
CONTROL SOLENOID VALVE	S2A, S2B, S3A, S3B	TP8101-1D	TP8101-1D	TP8101-1D	TP8101-1D
CONTROL SOLENOID VALVE	S1, S4, S7, S8	TP8101-1D	TP8101-1D	TP8101-1D	TP8101-1D
DRAIN VALVE	S10, S11	TP8002	TP8002	TP8002	TP8002
MUFFLER, EXHAUST	ES1, ES2	TP4210-1	TP4210-1	TP4210-1	TP4210-1
FILTER, CONTROL AIR	CF1	TP2201-P	TP2201-P	TP2201-P	TP2201-P
SAFETY RELIEF VALVE	PSV1, PSV2	TP7110	TP7120	TP7120	TP7120
PRESSURE GAUGE	PI1, PI2	LP1020	LP1045	LP1045	LP1045
ORIFICE 2% COOLING	RO1	TP4337	TP4343	TP4343	TP4350
BACKUP PURGE ORIFICE	RO2	TP4150-.75	TP4156	TP4162	TP4168
THERMOCOUPLE	TC1,TC2,TC3,TC4,TC5,TC6	TP2082-UNGRD	TP2082-UNGRD	TP2082-UNGRD	TP2082-UNGRD
VESSEL MANWAY GASKET	AV1, AV2		FM21216-G	FM21216-G	FM21216-G
HEATER	HT1	TP3630-1-60-4	TP3638-4	TP3650-4	TP3660-4
BLOWER	BL1	TP1775-1	TP1796-4	TP1798-4	TP1798-4
PRESSURE TRANSDUCER	PT1, PT2, PT3, PT4	TP2451	TP2451	TP2451	TP2451
FLOW SWITCH	FS1	DP6010	DP6010	DP6010	DP6010
HEATER CONTACTOR	C1, C2, C3, C4	ES5075	ES5075	ES5075	ES5075
BLOWER CONTACTOR	MS1	ES5003-10AF	ES5003-10AF	ES5003-10AF	ES5003-10AF
STARTER OVERLOAD	OL	ES5001-TF-13.0	ES5001-TF-16.0	ES5001-TF-24.0	ES5001-TF-24.0
HEATER FUSE		EF3050-F	EF3060-F	EF3040-F	EF3050-F
BLOWER FUSE		EF3020	EF3025	EF3035	EF3035
PLC	PLC1	TP2681-PLC-B9000	TP2681-PLC-B9000	TP2681-PLC-B9000	TP2681-PLC-B9000
HMI DISPLAY	HMI	TP2681-HMI-B9000	TP2681-HMI-B9000	TP2681-HMI-B9000	TP2681-HMI-B9000
POWER SUPPLY		2080-PS120-240V	2080-PS120-240V	2080-PS120-240V	2080-PS120-240V
FUSE, 1 AMP	F1	EF0100-2-TD	EF0100-2-TD	EF0100-2-TD	EF0100-2-TD
FUSE, 2 AMP	F2	EF0200-2-TD	EF0200-2-TD	EF0200-2-TD	EF0200-2-TD
FUSE, 1/4 AMP	F3	EF0025-TD	EF0025-TD	EF0025-TD	EF0025-TD
MEMORY CARD		TP2681-MEM	TP2681-MEM	TP2681-MEM	TP2681-MEM
DEWPOINT PROBE	AE1	TP2190-1-UL	TP2190-1-UL	TP2190-1-UL	TP2190-1-UL
<b>MODELS WITH NEMA 4</b>					
NEMA 4 THERMOCOUPLE	TC1,TC2,TC3,TC4,TC5,TC6	TP2083-N4	TP2083-N4-12	TP2083-N4-12	TP2083-N4-12
<b>MODELS WITH OUTDOOR PACKAGE</b>					
BLOWER INTAKE ELEMENT	BF1				
<b>MODELS WITH INSTRUMENTATION OPTION</b>					
PRESSURE GAUGE	PI4, P5	LP1020	LP1045	LP1045	LP1045
TEMPERATURE GAUGE	TG1, TG2	LT3250-.25	LT3250-.25	LT3250-.25	LT3250-.25

## Blower Purge Spare Parts List (Flow schematic drawing# FS11688)

	MODEL	TWB4001	TWB5001	TWB6001	TWB7501
<b>DESICCANT</b>	<b>PART ID</b>	<b>PART NUMBER</b>			
DESICCANT 25LB BAGS (QTY)	AV1, AV2	PDA-1/8-25 (232)	PDA-1/8-25 (288)	PDA-1/8-25 (352)	PDA-1/8-25 (456)
<b>FILTER ELEMENTS</b>					
COALESCER ELEMENT (QTY)	PF1, PF2	JE-C1501 (3)	JE-C1501 (4)	JE-C1501 (4)	JE-C1501 (7)
PARTICULATE ELEMENT (QTY)	AF1, AF2	JE-FC4000-HT (1)	JE-FC4000-HT (1)	JE-FC2500-HT (3)	JE-FC2500-HT (4)
CONTROL AIR FILTER ELEMENT (QTY)	CF1	TP2201-PE (1)	TP2201-PE (1)	TP2201-PE (1)	TP2201-PE (1)
BLOWER INTAKE ELEMENT	BF1	TP1451-SDB-E	2C040-003	2C040-003	2C040-001
<b>REPAIR KITS</b>					
INLET VALVE REPAIR KIT	PV2, PV3	TP7661-BD-HP-RK	TP7661-BD-HP-RK	TP7661-BD-HP-RK	TP7681-BD-HP-RK
INLET VALVE ACTUATOR	PV2, PV3	TP7631-BD-HP-A	TP7631-BD-HP-A	TP7631-BD-HP-A	TP7681-BD-HP-A
EXHAUST VALVE REPAIR KIT	PV1, PV4	TP7641-BD-HP-RK	TP7641-BD-HP-RK	TP7661-BD-HP-RK	TP7661-BD-HP-RK
EXHAUST VALVE ACTUATOR	PV1, PV4	TP7542-B-HP-A	TP7542-B-HP-A	TP7562-B-HP-A	TP7562-B-HP-A
PRE EXHAUST VALVE REPAIR KIT	PV7, PV8	TP7520-P1-RK	TP7520-P1-RK	TP7520-P1-RK	TP7520-P1-RK
OUTLET CHK VALVE REPAIR KIT	CV1, CV2	TP7461-SWRK	TP7461-SWRK	TP7461-SWRK	TP7481-SWRK
PURGE CHK VALVE REPAIR KIT	CV3, CV4	TP7441-SWRK	TP7461-SWRK	TP7461-SWRK	TP7461-SWRK
2% CHK VALVE REPAIR KIT	CV5, CV6	TP7415-AB-RK	TP7415-AB-RK	TP7415-AB-RK	TP7420-AB-RK
2% COOLING VALVE REPAIR KIT	PV6	TP7610-P1-RK	TP7610-P1-RK	TP7610-P1-RK	TP7615-P1-RK
REPRESS VALVE REPAIR KIT	PV5	TP7615-P1-RK	TP7615-P1-RK	TP7615-P1-RK	TP7620-P1-RK
<b>REPLACEMENT PARTS</b>					
INLET VALVE	PV2, PV3	TP7661-BD-HP	TP7661-BD-HP	TP7661-BD-HP	TP7681-BD-HP
EXHAUST VALVE	P1, PV4	TP7542-B-HP	TP7542-B-HP	TP7562-B-HP	TP7562-B-HP
PRE EXHAUST VALVE	PV7, PV8	TP7520-P1	TP7520-P1	TP7520-P1	TP7520-P1
OUTLET CHECK VALVE	CV1, CV2	TP7461-SW	TP7461-SW	TP7461-SW	TP7481-SW
PURGE CHECK VALVE	CV3, CV4	TP7441-SW	TP7461-SW	TP7461-SW	TP7461-SW
2% CHECK VALVE	CV5, CV6	TP7415-AB	TP7415-AB	TP7415-AB	TP7420-AB
2% COOLING VALVE	PV6	TP7610-P1	TP7610-P1	TP7610-P1	TP7615-P1
2% COOLING CONTROL VALVE	S6	TP8101-D	TP8101-D	TP8101-D	TP8101-D
REPRESS CONTROL VALVE	S5	TP8101-D	TP8101-D	TP8101-D	TP8101-D
REPRESSURIZATION VALVE	PV5	TP7615-P1	TP7615-P1	TP7615-P1	TP7620-P1
CONTROL SOLENOID VALVE	S2A, S2B, S3A, S3B	TP8101-1D	TP8101-1D	TP8101-1D	TP8101-1D
CONTROL SOLENOID VALVE	S1, S4, S7, S8	TP8101-1D	TP8101-1D	TP8101-1D	TP8101-1D
DRAIN VALVE	S10, S11	TP8003	TP8003	TP8003	TP8003
MUFFLER, EXHAUST	ES1, ES2	TP4220-1	TP4220-1	TP4220-1	TP4220-1
FILTER, CONTROL AIR	CF1	TP2201-P	TP2201-P	TP2201-P	TP2201-P
SAFETY RELIEF VALVE	PSV1, PSV2	TP7120	TP7120	TP7120	TP7120
PRESSURE GAUGE	PI1, PI2	LP1045	LP1045	LP1045	LP1045
ORIFICE 2% COOLING	RO1	TP4356	TP4362	TP4368	TP4375
BACKUP PURGE ORIFICE	RO2	TP4175	TP4187	TP41100	TP41112
THERMOCOUPLE	TC1,TC2,TC3,TC4,TC5,TC6	TP2082-UNGRD	TP2082-UNGRD	TP2082-UNGRD	TP2082-UNGRD
VESSEL MANWAY GASKET	AV1, AV2	FM21216-G	FM21216-G	FM21216-G	FM21216-G
HEATER	HT1	TP3685-4	TP37100-8	TP37120-N4	TP37150-N4
BLOWER	BL1	TP1798-SDB	TP1799-SDB	TP1799-SDB	TP1799-25
BLOWER BELT		2A041-539	2A041-539	2A041-539	2A045-533
BLOWER TENSIONER WITH IDLER		B003-429	B003-429	B003-429	
BLOWER IDLER, DUAL BEARING		2C116-001	2C116-001	2C116-001	2C116-002
BLOWER DAMPER		2C111-044	2C111-044	2C111-044	
BLOWER HEAD		2C228-081	2C228-081	2C228-081	2C228-091
PRESSURE TRANSDUCER	PT1, PT2, PT3, PT4	TP2451	TP2451	TP2451	TP2451
FLOW SWITCH	FS1	DP6010	DP6010	DP6010	DP6010
HEATER CONTACTOR	C1,C2,C3,C4,C5,C6,C7,C8	ES5075	ES5075	ES5075	ES5075
BLOWER CONTACTOR	MS1	ES5003-20AF	ES5003-20AF	ES5003-30AF	ES5003-30AF
STARTER OVERLOAD	OL	ES5001-TF-24.0	ES5001-TF-29.0	ES5001-TF-29.0	ES5001-TF-35.0
HEATER FUSE		EF3050-F	EF3040-F	EF3060-F	EF3060-F
BLOWER FUSE		EF3030	EF3045	EF3045	EF3060
PLC	PLC1	TP2681-PLC-B9000	TP2681-PLC-B9000	TP2681-PLC-B9000	TP2681-PLC-B9000
HMI DISPLAY	HMI	TP2681-HMI-B9000	TP2681-HMI-B9000	TP2681-HMI-B9000	TP2681-HMI-B9000
POWER SUPPLY		2080-PS120-240V	2080-PS120-240V	2080-PS120-240V	2080-PS120-240V
FUSE, 1 AMP	F1	EF0100-2-TD	EF0100-2-TD	EF0100-2-TD	EF0100-2-TD
FUSE, 2 AMP	F2	EF0200-2-TD	EF0200-2-TD	EF0200-2-TD	EF0200-2-TD
FUSE, 1/4 AMP	F3	EF0025-TD	EF0025-TD	EF0025-TD	EF0025-TD
MEMORY CARD		TP2681-MEM	TP2681-MEM	TP2681-MEM	TP2681-MEM
DEWPOINT PROBE	AE1	TP2190-1-UL	TP2190-1-UL	TP2190-1-UL	TP2190-1-UL
<b>MODELS WITH NEMA 4</b>					
NEMA 4 THERMOCOUPLE	TC1,TC2,TC3,TC4,TC5,TC6	TP2083-N4-12	TP2083-N4-12	TP2083-N4-12	TP2083-N4-12
<b>MODELS WITH OUTDOOR PACKAGE</b>					
BLOWER INTAKE ELEMENT	BF1				
<b>MODELS WITH INSTRUMENTATION OPTION</b>					
PRESSURE GAUGE	PI4, P5	LP1045	LP1045	LP1045	LP1045
TEMPERATURE GAUGE	TG1, TG2	LT3250-.25	LT3250-.25	LT3250-.25	LT3250-.25

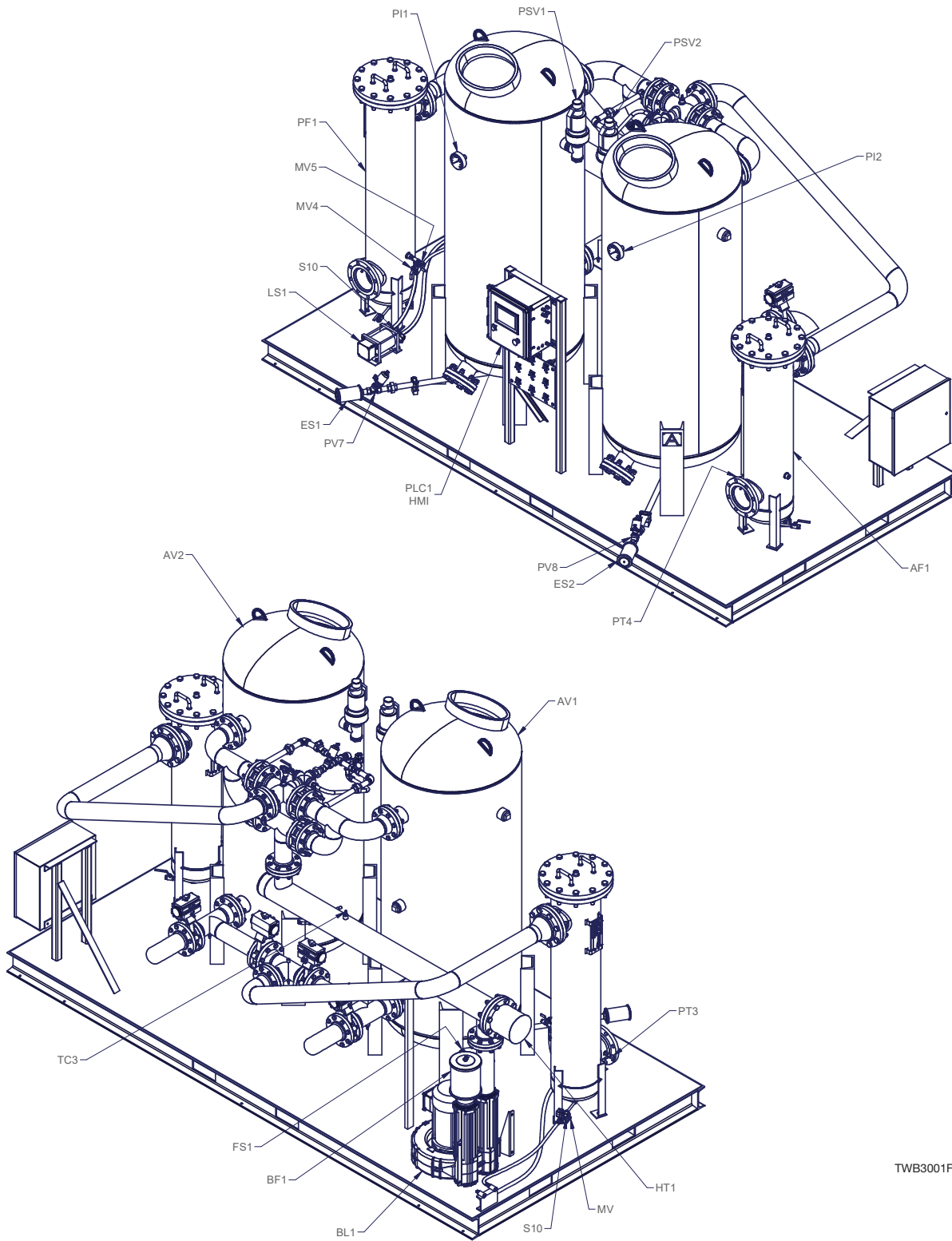

TWB3001FY41NNN-MAN REV-

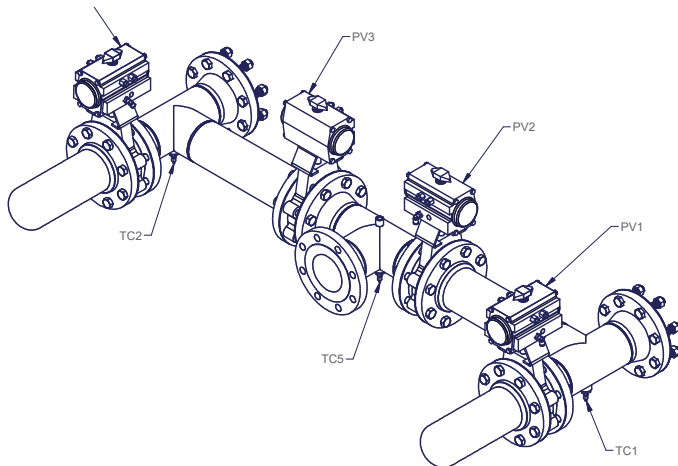
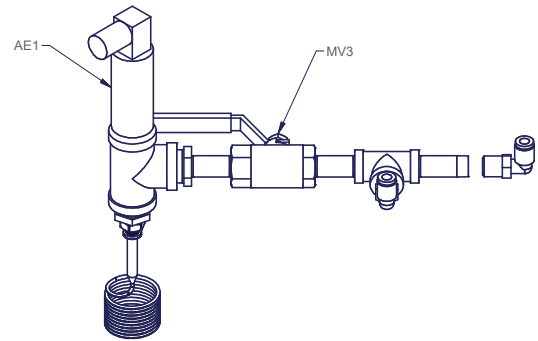
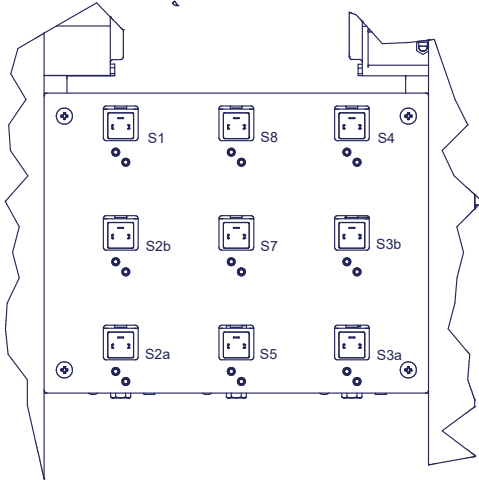
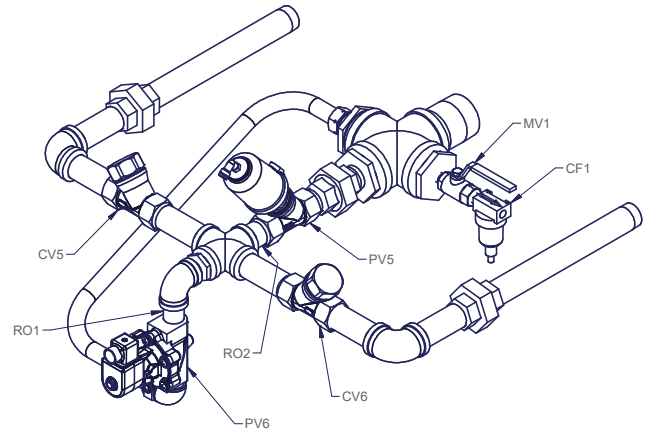
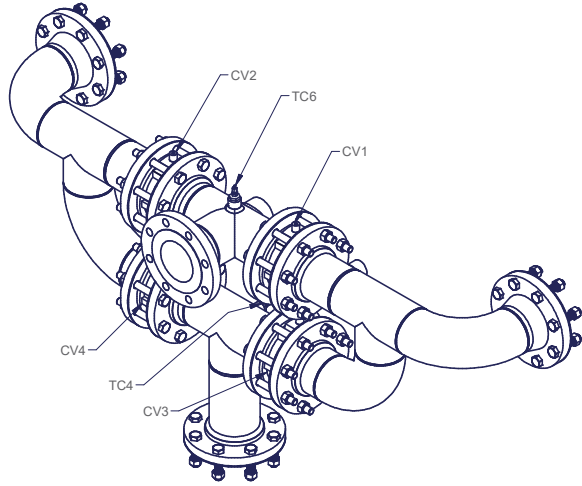

TWB3001FY41NNN-MAN REV-

## TROUBLESHOOTING

### Dryer not operating; no lights on

- Blown control fuse: replace fuse.
- No power: apply correct power, verify quality of power source.
- Controller inoperative: replace controller.
- Control transformer defective: replace transformer.
- Program crashes: replace SD card.

### Power light on, other lights off, dryer does not operate

- Cycle has not been initiated: press start button.

### Dryer not operating; lights on, dryer does not switch

- Control air valve is closed: open control air valve; check condition of control air filter element.
- No air supply to dryer inlet: connect air supply.
- Dryer in Power Saving State: Disable Dewpoint Demand to go back to a standard timing cycle.

### No heat in regenerating bed

- Regenerating tower will not blow down: dryer not sequencing or in dewpoint demand mode: see above.
- Bad output, solenoid, or exhaust: replace part or correct issue.

### Dryer cycles, no heat

- Dryer in heatless backup mode: switch to heated mode and press start button.
- Overtemp shutdown engaged: Check setting and press reset; if overtemp shuts down dryer again consult factory.
- Thermocouple disconnected or defective: reconnect or replace.
- Purge flow set to low: adjust purge setting to spec (TWP dryers only).

### Insufficient Heat

- Low purge flow: adjust purge setting to spec (TWP dryers only).
- Clogged muffler: clean, replace, or remove.
- Moisture load too high: adjust dryer inlet air flow conditions to within spec.
- Defective thermocouple or controller: replace.

### High Outlet Dewpoint or Moisture Downstream

- Dryer not cycling: see dryer not operating.
- Insufficient or no heat: see above.
- Incorrect purge rate: adjust purge setting to value specified on purge tag or manual.
- Capacity of dryer exceeded: adjust inlet flow rate, inlet air temperature, and inlet air pressure to within specified operating conditions for the model.
- Liquid water present at dryer inlet: check water level in separators, receivers, prefilters, and operation of associated y-strainers and auto drains. Check condition of filter elements or check differential pressure gauges.
- Desiccant worn out, contaminated, or insufficient quantity: replace desiccant or add correct amount.
- Reduced regeneration: see **Back Pressure In Regenerating Tower**.
- Leaking bypass valve: replace valve.
- Undried air from another source mixing downstream of dryer: remedy.

### **Excessive Air Loss On Regenerating Tower**

- Purge pressure set too high: check specifications and adjust.
- Repressurization solenoid leaking: repair, clean, or replace.
- Inlet valve leaking or not functioning: See inlet valve not functioning.
- Leaking check valve: repair, clean, or replace.
- Leaking or inoperative control solenoid: repair or replace.
- Defective controller: repair or replace.

### **Exhaust Valve On Drying or Repressurizing Tower Leaking**

- Valve dirty: clean valve.
- Defective diaphragms or seals: rebuild valve or replace.
- Leaking control solenoid: repair or replace.

### **Excessive Pressure Drop**

- Prefilter or afterfilter fully saturated or collapsed: replace element.
- Desiccant contaminated with oil: replace desiccant.
- Excessive flow: reduce air flow rate to within product specs.

### **Unit Does Not Fully Pressurize**

- Purge rate too low: Adjust purge pressure setting.
- Exhaust valve leaking: see exhaust valve leaking.
- Purge orifice or repressurization valve plugged: clean.

### **Back Pressure In Regenerating Tower**

- Clogged mufflers: clean, repair, or replace.
- Check valve leaking: clean, repair, or replace.
- Purge flow too high: adjust purge pressure.
- Leaking inlet valve: See inlet valve not functioning.

### **Inlet or Exhaust Valve Not Functioning**

- Bad seals or solenoid: rebuild valves with available kits or replace.
- No output from controller: replace fuse or controller.
- Valve dirty: rebuild or clean.

### **Blower not operating (TWB dryers only)**

- Overload tripped: clogged blower inlet filter; replace.
- Blower deadheaded: determine cause.
- V-Belts broken: replace.

### **Amp draw is over nameplate rating (TWB4000-9000 onl)**

- Air flow through blower is too high: choke off blower manual control valve.

**Please note: When factory assistance is required, always provide serial number, model number, and full description of problem.**



## TECHNICAL SPECIFICATIONS

### Blower Purge Dryer Technical Specs

Model	Capacity SCFM	Min PSI	Max PSI	Air In/Out Size	Air In/Out Connection	Power	FLA	Heater KW	Blower HP	Dryer Avg KW	LBS Desiccant per Vessel	Operating Weight LBS
201	200	80	150	1 1/2 IN	NPT	460/3/60	11.7	6	1	2.8	150	1500
301	300	80	150	1 1/2 IN	NPT	460/3/60	13.1	6	2	4.5	235	1900
401	400	80	150	2 IN	NPT	460/3/60	18.0	9	3	6.2	300	2180
501	500	80	150	2 IN	NPT	460/3/60	23.0	12	4	7.8	375	2840
601	600	80	150	2 IN	NPT	460/3/60	23.0	12	4	9.0	450	3420
801	800	80	150	2 IN	NPT	460/3/60	28.6	15	5.5	12.1	600	4490
1001	1000	80	150	3 IN	FLG	460/3/60	32.2	18	5.5	14.5	725	5700
1201	1200	80	150	3 IN	FLG	460/3/60	40.6	25	5.5	16.8	850	6300
1501	1500	80	150	3 IN	FLG	460/3/60	48.8	30	7.5	21.3	1100	7165
2001	2000	80	135	4 IN	FLG	460/3/60	61.2	38	10	28.5	1500	9850
2601	2600	80	135	4 IN	FLG	460/3/60	81.8	50	15	37.9	1900	12210
3001	3000	80	135	6 IN	FLG	460/3/60	93.9	60	15	42.7	2200	12650
4001	4000	80	135	6 IN	FLG	460/3/60	122.7	85	15	54.6	2900	18910
5001	5000	80	135	6 IN	FLG	460/3/60	147.1	100	20	68.8	3600	21590
6001	6000	80	135	6 IN	FLG	460/3/60	171.1	120	20	80.7	4400	24890
7501	7500	80	135	8 IN	FLG	460/3/60	212.9	150	25	100.8	5700	29490

Design Conditions of 100 psig at 100°F inlet air, 40° to 100°F ambient air

To obtain dryer capacity at different operating conditions, multiply nominal capacity X temperature correction factor X pressure correction factor

Maximum Inlet Temperature	°F	90	95	100	105	110	115	120
Temperature Correction Factor		1.17	1.15	1.00	0.87	0.76	0.66	0.58
Minimum Inlet Pressure	psig	80	90	100	110	120	130	
Pressure Correction Factor		0.83	0.91	1.00	1.09	1.17	1.26	

Externally Heated Dryer Technical Specs

Model	Capacity SCFM	Min PSI	Max PSI	Air In/Out Size	Air In/Out Connection	Power	FLA	Heater KW	Dryer Avg KW	LBS Desiccant per Vessel	Purge Setting PSI	Purge Air Loss SCFM	Purge Orifice Size	Operating Weight LBS
201	200	80	150	1 1/2 IN	NPT	240/1/60	11.3	2	1.2	150	34	16	3/16"	920
251	250	80	150	1 1/2IN	NPT	240/1/60	11.3	2	1.5	180	46	20	3/16"	1180
301	300	80	150	1 1/2IN	NPT	480/3/60	6.6	3	1.9	235	58	24	3/16"	1370
401	400	80	150	2 IN	NPT	480/3/60	10.2	6	2.5	300	40	32	1/4"	1700
501	500	80	150	2 IN	NPT	480/3/60	10.2	6	3.1	375	54	40	1/4"	2060
601	600	80	150	2 IN	NPT	480/3/60	13.8	9	3.7	450	38	48	5/16"	2350
801	800	80	150	2 IN	NPT	480/3/60	13.8	9	4.9	600	55	64	5/16"	3035
1001	1000	80	150	3 IN	FLG	480/3/60	17.4	12	6.2	725	46	80	3/8"	4195
1201	1200	80	150	3 IN	FLG	480/3/60	17.4	12	7.4	850	58	96	3/8"	5215
1501	1500	80	150	3 IN	FLG	480/3/60	24.7	18	9.3	1100	52	120	7/16"	7765
2001	2000	80	135	4 IN	FLG	480/3/60	33.1	25	12.3	1500	30	160	5/8"	8565
2601	2600	80	135	4 IN	FLG	480/3/60	33.1	25	16.0	1900	46	208	5/8"	11562
3001	3000	80	135	6 IN	FLG	480/3/60	39.1	30	18.5	2200	31	240	3/4"	12002
4001	4000	80	135	6 IN	FLG	480/3/60	63.1	50	24.7	2900	46	320	3/4"	18260
5001	5000	80	135	6 IN	FLG	480/3/60	63.1	50	30.9	3600	30	400	1"	19760
6001	6000	80	135	6 IN	FLG	480/3/60	75.2	60	37.0	4400	37	480	1"	22260
7501	7500	80	135	8 IN	FLG	480/3/60	105.2	85	46.3	5700	50	600	1"	26860

Design Conditions of 100 psig at 100°F inlet air, 40° to 100°F ambient air

To obtain dryer capacity at different operating conditions, multiply nominal capacity X temperature correction factor X pressure correction factor

Maximum Inlet Temper: °F	90	95	100	105	110	115	120
Temperature Correction Factor	1.17	1.15	1.00	0.87	0.76	0.66	0.58

Minimum Inlet Pressure psig	80	90	100	110	120	130
Pressure Correction Factor	0.83	0.91	1.00	1.09	1.17	1.26

# Parker Filtration Group

**Aerospace Filtration Division**  
Greensboro, North Carolina  
336 668 4444

**Bioscience & Water Filtration Division**  
Bioscience Filtration  
Oxnard, California  
877 784 2234

Water Purification  
Carson, California  
310 608 5600

**Engine Mobile Aftermarket Division**  
Kearney, Nebraska  
308 234 1951

**Engine Mobile Original Equipment Division**  
Modesto, California  
209 521 7860

**HVAC Filtration Division**  
Jeffersonville, Indiana  
866 247 4827

**Hydraulic & Fuel Filtration Division**  
Metamora, Ohio  
419 644 4311

**Industrial Gas Filtration & Generation Division**  
Lancaster, NY  
800 343 4048

**Industrial Process Filtration Division**  
Mineral Wells, Texas  
940 325 2575

**Bioscience Engineering Filtration Division EMEA**  
Birtley, United Kingdom  
+44 (0) 191 410 5121

**Engine Mobile Filtration Division EMEA**  
Dewsbury, United Kingdom  
+44 (0) 1924 487 037

**Gas Separation & Filtration Division EMEA**  
Team Valley, United Kingdom  
+44 (0) 191 402 9000

**Gas Turbine Filtration Division**  
Alton, United Kingdom  
+44 (0) 1420 541188

**Hydraulic & Industrial Filtration Division EMEA**  
Arnhem, Netherlands  
+31 (0) 26 376 0376

**Australia Filtration Division**  
Castle Hill, Australia  
+61 2 9634 7777

**China Filtration Division**  
Shanghai, China  
+86 21 2067 2067

**India Filtration Division**  
Chennai, India  
+91 22 4391 0700

**Korea Filtration Division**  
Hwaseon City, Korea  
+82 31 359 0852

**Latin America Filtration Division**  
Sao Paulo, Brazil  
+55 12 4009 3500



© 2021 Parker Hannifin Corporation. Product names are trademarks or registered trademarks of their respective companies.

MAN-TWPB-AB Rev D 052021



Parker Hannifin Corporation  
**Industrial Gas Filtration and Generation Division**  
4087 Walden Avenue  
Lancaster, NY 14086  
phone 800 343 4048  
[www.parker.com/igfg](http://www.parker.com/igfg)

