

Axial Piston Pumps

Series eP2/eP3 - Electronic Controls
Variable Displacement



parker.com/pmde



ENGINEERING YOUR SUCCESS.

Contents

Contents	Page
General Information.....	3
Introduction	3
Technical Features	3
Customer Benefits	3
Ordering Code	4
Electronic Control Options.....	5
Electronic Displacement Controls EC and EF	5
Electronic Control Options	6
Control Functions and Options	6
Control Schematics.....	6
Technical Data	8
Pump Control Module - PCM.....	9
Ordering Code 1450039	9
Technical Data	9
Dimensions.....	10
eP2075.....	10
eP2075 w/ pressure sensor	12
eP2105.....	13
eP2105 w/ pressure sensor	15
eP2145.....	16
eP2145 w/ pressure sensor	18
eP3105.....	19
eP3105 w/ pressure sensor	21
eP3145.....	22
eP3145 w/ pressure sensor	24
General Installation Information.....	25

Conversion factors

1 kg.....	2.20 lb
1 N.....	0.225 lbf
1 Nm.....	0.738 lbf ft
1 bar	14.5 psi
1 l.....	0.264 US gallon
1 cm ³	0.061 cu in
1 mm.....	0.039 in
$\frac{9}{5} \text{ }^\circ\text{C} + 32$	1 $^\circ\text{F}$
1 kW	1.34 hp

Introduction

Parker's P2 / P3 series has been designed to meet the specific demands of heavy duty mobile applications throughout the following markets:

- Material Handling Equipment (e.g Reachstacker, HD Lift Trucks, AT Cranes)
- Construction Equipment (e.g. Articulated Dump Trucks, Wheel Loaders)
- Mining and Drilling (e.g. Dump Trucks, Drill Rigs)
- Forestry Equipment (e.g. Forwarder, Harvester)

By featuring an optimized envelope and a unique port layout the product line provides for a cost saving direct mount on most typical mobile transmissions. High speed ratings enable high flow and productivity levels. With continuous pressure ratings of up to 350 bar P2 / P3 provides a high power density and enables downsizing of mobile machinery. As a standard every P2 / P3 comes with an integrated pre-compression volume which ensures low ripple operation and reduced noise emissions.

After having proven in load-sensing systems for many years Parker's series P2 / P3 is now extended by a new electronic control concept (eP2 / eP3), setting new standards in responsiveness, stability and efficiency.

Technical Features

- Variable displacement, axial piston pumps for open circuit hydraulic systems
- Electronic displacement control with optional pressure limitation, input torque limitation and speed compensation (flow control)
- Electronic displacement feedback
- Optional electronic pressure feedback
- Available as standard (eP2075, eP2105, eP2145) and supercharged version (eP3105, eP3145)



Customer Benefits

- Increased fuel efficiency by considerably reduced control losses
- Opportunity to eliminate LS losses by the introduction of a new electro-hydraulic system approach
- High productivity by outstanding responsiveness and stability of the closed loop displacement control as well as maximized output flow
- Increased machine availability and improved sub-system communication by condition monitoring opportunities
- Cost saving installation by direct PTO mount
- High altitude operation capability
- Low noise level and reduced flow ripple

Technical Data

Series and Pump Size		eP2075	eP2105	eP2145	eP3105	eP3145
Maximum displacement	[cm ³ /rev]	75	105	145	105	145
Self priming speed at 1 bar absolute inlet pressure ¹⁾	[rpm]	2500	2300	2200	2600	2500
Nominal pressure ²⁾	[bar]	320	350	350	350	350
Minimum inlet pressure, absolute	[bar]	0,8	0,8	0,8	0,8	0,8
Maximum inlet pressure, absolute	[bar]	10	10	10	1,5	1,5
Maximum case drain pressure, absolute	[bar]	1,5	1,5	1,5	1,5	1,5
Minimum outlet pressure, absolute	[bar]	15	15	15	15	15
Weight with electronic displacement control (EC, EF)	[kg]	41,6	60,6	75,6	59,6	73,6
Mass moment of inertia (at axis of shaft)	[kg m ²]	0,0101	0,0168	0,0241	0,0177	0,0264

¹⁾ Detailed inlet characteristics (at varying speed, displacement and inlet pressure conditions) can be taken from catalog HY30-2800/UK

²⁾ For maximum operating pressures exceeding above mentioned nominal ratings please consult manufacturer.

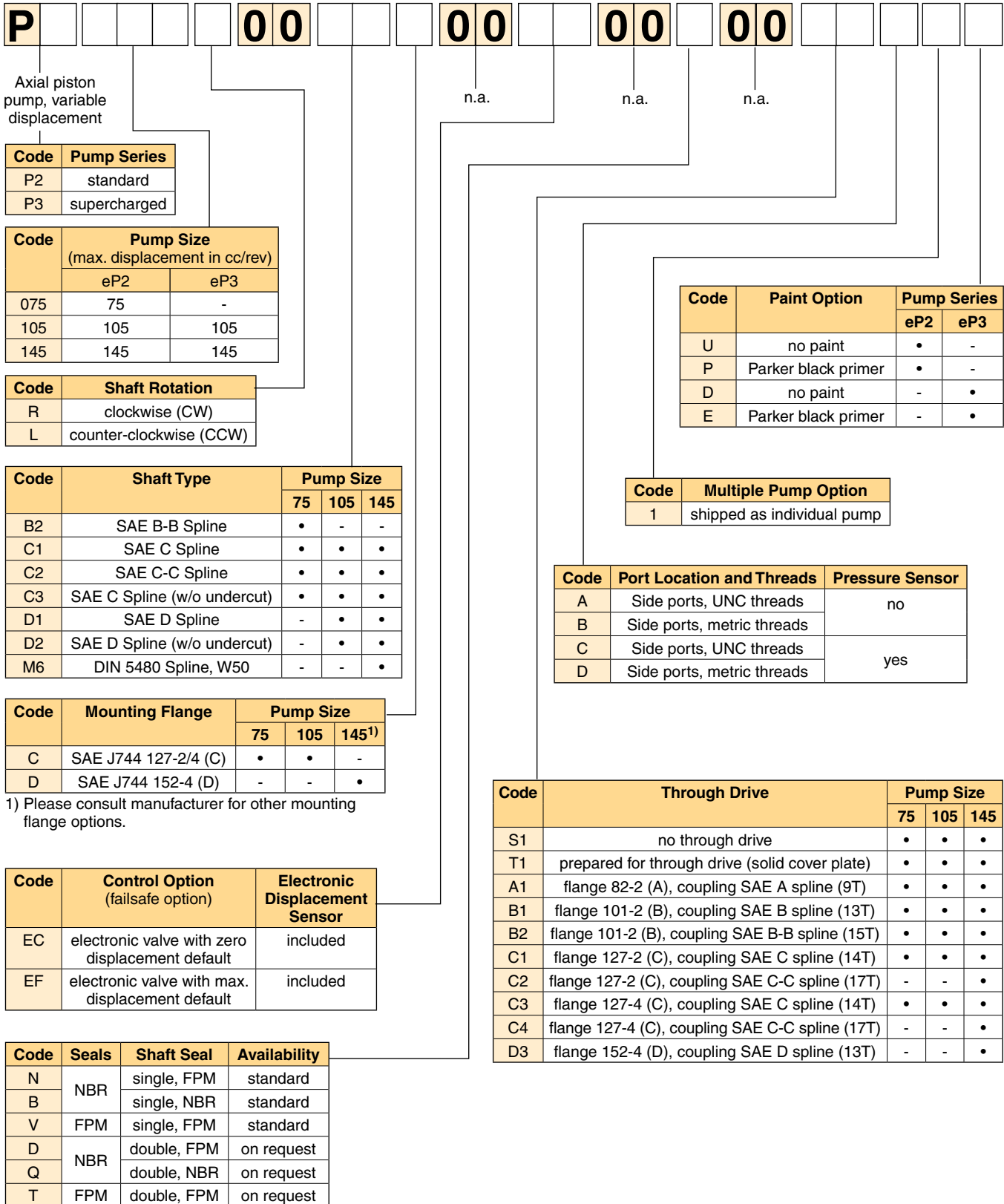

Electronic Displacement Controls EC and EF

Electronically displacement controlled eP2 / eP3 provides an output flow defined by a displacement input command and maintains its swash angle (and thereby output flow level) until a new displacement command is received.

Under static displacement control conditions - i.e. as long as actual pump displacement (actual value) corresponds to displacement command (nominal value) - the control spool of the pump's control valve is held at metering edge (zero point). This is realized by applying a defined holding current (PWM signal) to the valve's proportional solenoid. If commanded displacement changes (actual value ≠ nominal value) the control spool is moved from its zero point. Depending on specified default setting (EC: 0% displacement / EF: 100% displacement) raising the current either results in an increased (EC) or decreased (EF) displacement of the pump. As soon as desired displacement has been achieved (actual value = nominal value) the control spool returns to its zero point.

Default options (behaviour at power loss):

EC 0% (zero displacement)

EF 100% (maximum displacement)

A minimum servo pressure of 15 bar is required to control the pump. Without adequate servo pressure the pump is mechanically biased on stroke. If a system pressure of below 15 bar is required the pump might be equipped with a preload valve. Please consult Parker for further information.

Closed control loop

By featuring both an electro-proportional directional control valve and a swash angle sensor the eP2 / eP3 design takes advantage of a closed control loop which provides for:

- Increased accuracy and system response
- Higher stability and minimized oscillation
- Improved fuel efficiency
- Electronic displacement feedback for analysis and sub-system communication

Closed loop working principle:

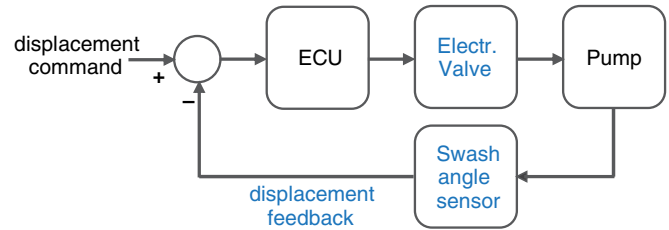

Power savings

Compared to a conventional hydro-mechanical compensator based approach the electronic displacement control of eP2 / eP3 is characterized by a significantly reduced compensator oil consumption and thereby increased volumetric efficiency. Thus eP2 / eP3 provides for considerable power savings (measured values at 1500 rpm):

	100 bar	300 bar
eP2075 power saving compared to LS controlled pump [kW]	0.2	0.85

Fuel saving potentials

Beside providing for improved control characteristics as well as power savings by control design eP2 / eP3 also enables new hydraulic system approaches such as the purely electronic control of single actuator operation, which eliminates the delta p losses of a conventional LS system.

Example:

$\Delta p = 20 \text{ bar}$

$Q = 150 \text{ L/min (75 cc/rev @ 2.000 rpm)}$

Resulting power consumption = 5 kW

Potential fuel saving @ 1.500 h/a and 0,2 l/kWh:

1.500 l/a

Typical response times

(Displacement control)

		100 bar	300 bar
t onstroke (10% to 90% displ.) [ms]	eP2075	120	95
	eP2105 / eP3105	125	100
	eP2145 / eP3145	130	110
t destroke (90% to 10% displ.) [ms]	eP2075	120	155
	eP2105 / eP3105	130	160
	eP2145 / eP3145	145	165

Control Functions and Options

As an option eP2 / eP3 can be equipped with a pressure sensor to either grant for pressure monitoring or to realize electronic pressure limitation. Pressure limitation function as well as secondary control options such as variable input torque limitation and speed compensation / flow control require the usage of a Parker supplied Pump Control Module (PCM). PCM command inputs can be both analog (0..5V) or CAN (J1939).

The following chart shows the range of available control functions (eff. March, 2018):

Control option	
Main	Secondary
D ¹⁾ displacement control	
DP ²⁾ displacement control w pressure limitation	
	T ²⁾ torque limitation
	S ²⁾ speed compensation / flow control

- 1) Can be realized with Parker PCM or customer ECU (closed control loop)
- 2) Requires Parker PCM

Beside pressure limitation (which defines a maximum pressure setting) a variable pressure control function can be made available on request. Please consult manufacturer for further details.

Note:

The hydraulic circuit must be equipped with a main flow relief valve to secure pump and hydraulic components. This main flow relief valve is outside the scope of supply.

Control Schematics

Displacement control w/o Parker supplied PCM

0% default setting (EC), standard valve position

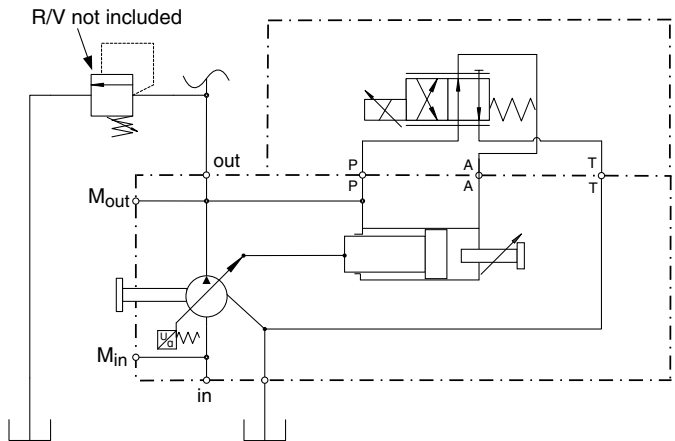

Displacement control w/o Parker supplied PCM

100% default setting (EF), standard valve position

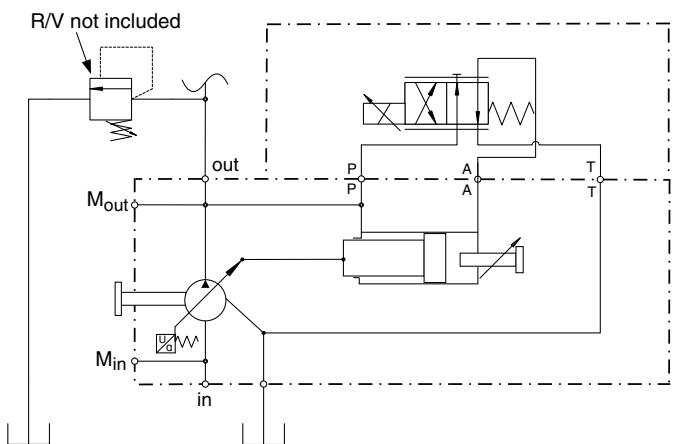

Technical Data

Proportional control valve

General	
Model	Parker D1FB series
Design	Direct operated proportional DC valve (4/2 design)
Connector	Deutsch DT04-2P
Mating connector	Deutsch DT06-2S
Protection class	IP 67 in accordance with EN 60529 (with correctly installed and mounted mating connector)
Wiring recommendation	Stranded wire cable, min. 0.75 mm ² (AWG 18)
Electrical characteristics	
Supply voltage	12 V (standard option)
Current consumption	2,2 A (standard option)
Nominal resistance (at 20 °C)	4,4 Ω
Recommended dither frequency	120 Hz
Recommended dither amplitude	4%
Operating time	100%

Swash angle sensor

General	
Model	Parker RS52 series
Design	Ratiometric hall effect sensor
Connector	Deutsch DT04-3P
Mating connector	Deutsch DT06-3S
Protection class	IP 67 in accordance with EN 60529 (with correctly installed and mounted mating connector)
Wiring recommendation	Stranded wire cable, min. 0.5 mm ² (AWG 20)
Electrical characteristics	
Supply voltage	5 VDC regulated
Current consumption	12 mA max.
Output signal voltage	[2,5...4,5]V (standard control valve position) [2,5...0,8]V (control valve on opposite side of pump)
Max. output voltage drift	0,5mV/°C
Sinusoidal vibration	MIL-STD-202G, method 204D, 10-2kHz, 10G peak, 8 hr/axis
Random vibration	MIL-STD-202G, method 214A, 5-2kHz, 7,68G rms, 8 hr/axis
Approvals	
CE	2014/30/EU, EMC Directive

Pressure sensor

General	
Model	Parker SCP02 series
Design	Ratiometric pressure sensor
Connector	Deutsch DT04-4P
Mating connector	Deutsch DT06-4S
Protection class	IP 67 in accordance with EN 60529 (with correctly installed and mounted mating connector)
Wiring recommendation	Stranded wire cable, min. 0.5 mm ² (AWG 20)
Electrical characteristics	
Supply voltage	5 VDC regulated
Current consumption	14 mA max.
Output signal voltage	[0,5...3,7]V (eP2075)
Max. output voltage drift	0,5 mV/°C
Vibration resistance	IEC 60068-2-6: 20g
Shock resistance	IEC 60068-2-27: 700g
Approvals	
CE	2014/30/EU, EMC Directive

Pump Control Module - PCM

Ordering Code 1450039

- Task oriented controller with eP2 / eP3 specific firmware
- Covers all primary and secondary control functions (see page 6)
- Can be operated as both stand alone module (analog inputs) or CAN module (J1939)
- High reliability connectors system for harsh mobile environment
- CE certified



Technical Data

General	
Model	Parker PCM
Design	IQAN task oriented controller with pump specific firmware
Weight	350 g
Temperature range	[-40...+85]°C
Protection class	IP 65 in accordance with EN 60529
Connector	Molex MX123, 66 pos. Ordering codes: Connector 20085114 Connector + 2.5 m cable 20085124
Electrical characteristics	
Supply voltage	[9...32]VDC
Current consumption at idle	typ. 180mA (24V)
	typ. 250mA (12V)
Network	
CAN buses	2
Protocols	IDP (IQAN diagnostic protocol)
	SAE J1939 for master communication
Approvals	
CE	2014/30/EU, EMC Directive
E-mark	ECE Regulation No. 10.05:2014, approval N° E5 10 R - 05313

Related documents

Further information regarding electronic components, functionality and integration of eP2 / eP3 can be taken from the following related documents:

MSG30-2901-INST (Installation, start up and setup manual - electronic controls)

MSG30-2902-INST (Installation and start up manual - PCM)

MSG30-2903-INST (Installation and start up manual - CAN PlugIn)

eP2075

Pump shown is a CW rotation eP2075 with proportional control valve and swash angle sensor. Dimensions for EC and EF control option are identical.

CCW pump will have inlet and outlet gage port on opposite side of rear cover.

If required by installation the control valve and the swashangle sensor can be positioned at opposite side of the pump. Please consult manufacturer for details.

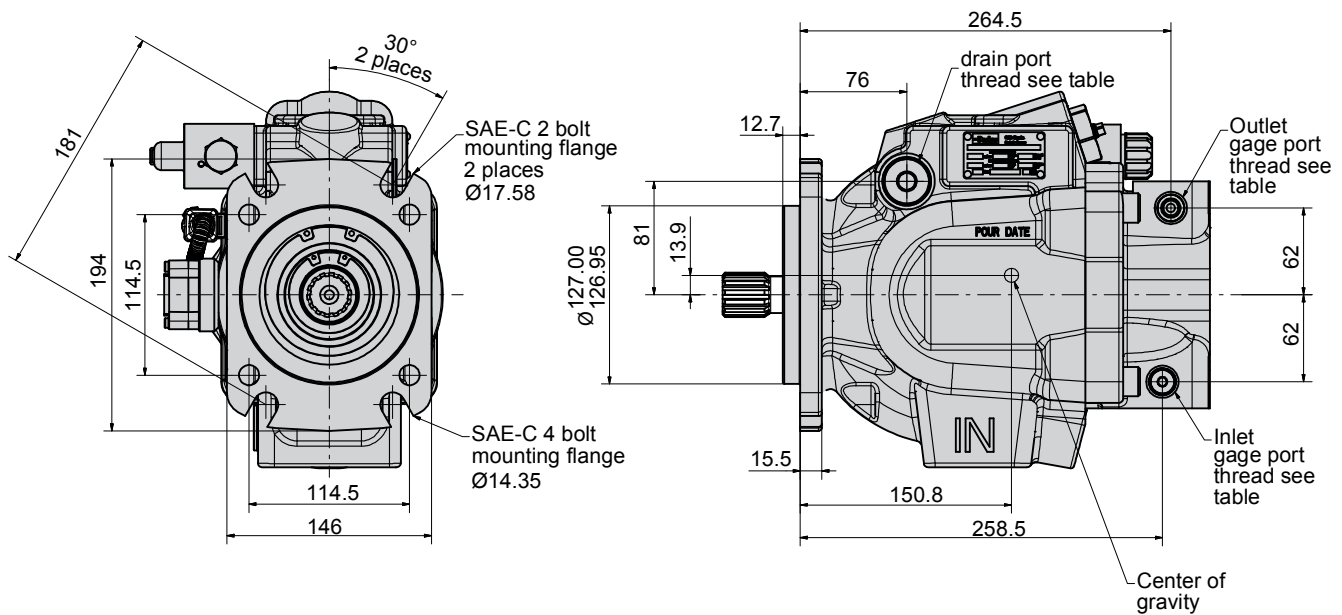

Port & threads option	Drain port	Inlet port	Outlet port	Inlet & outlet gage port
A / C (UNC)	SAE-12 straight thread / O-ring port: 1-1/16-12 thread	1/2-13 UN	7/16-14 UN	SAE-4 straight thread / O-ring port: 7/16-20 UN thread
B / D (metric)	ISO 6149 straight thread / O-ring port: M27 x 2 thread	M12 x 1,75	M12 x 1,75	ISO 6149 straight thread / O-ring port: M12 x 1,5 thread

eP2075

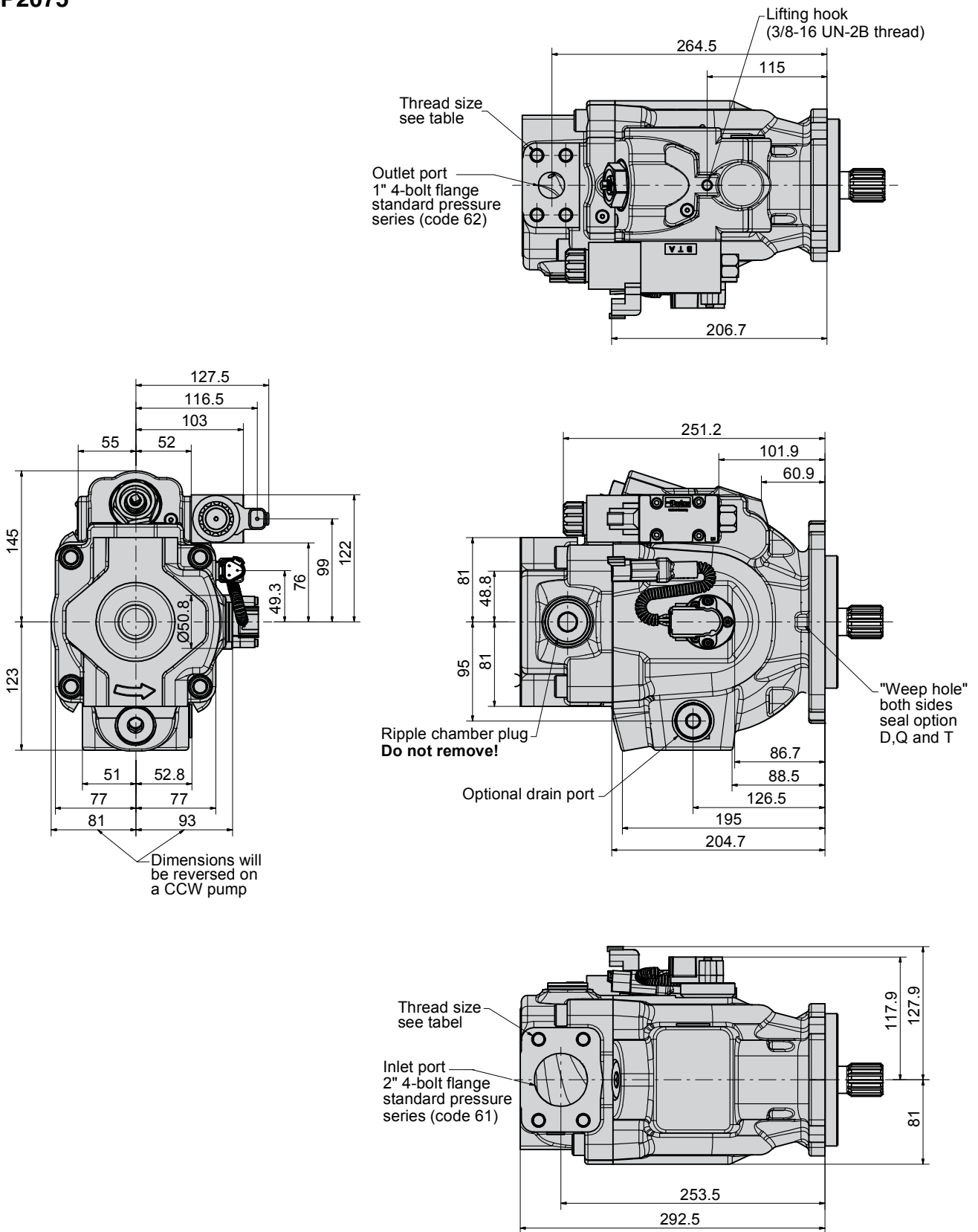

For thru drive dimensions and shaft information please check catalogue **MSG30-2800/UK** (Axial Piston Pumps – Series P2 / P3).

eP2075 w/ pressure sensor

Pump shown is a CW rotation eP2075 with proportional control valve, swash angle sensor and pressure sensor.

Port option C (pump with UNC threads)

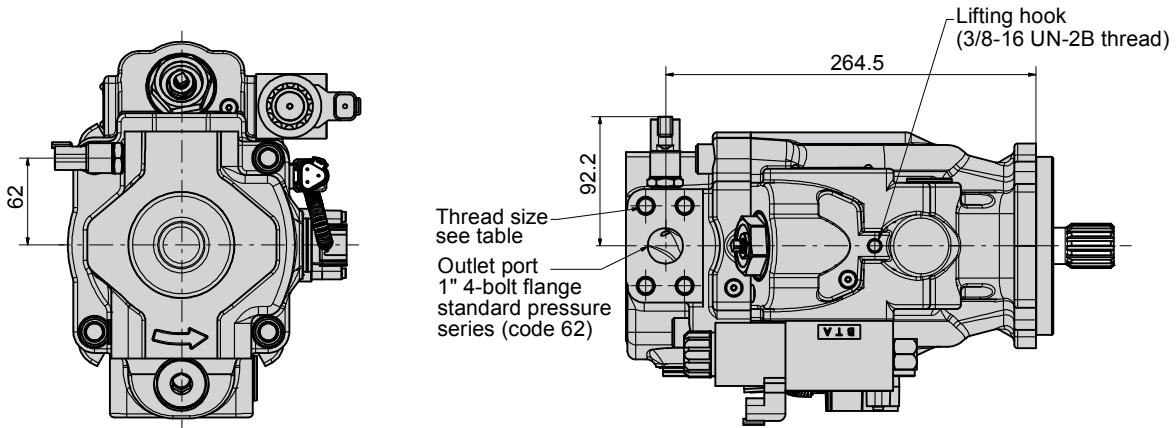

Port option D (pump with metric threads)

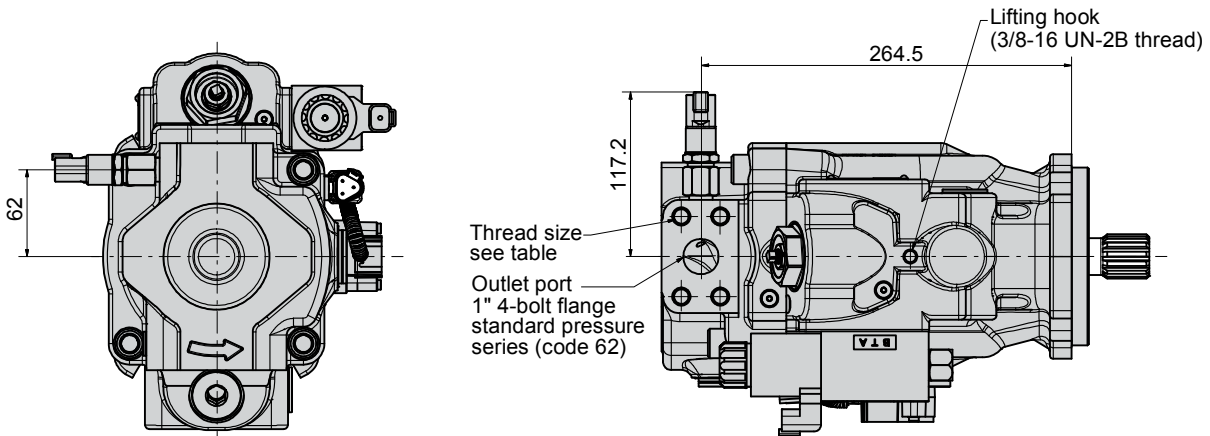

Port & threads option	Drain port	Inlet port	Outlet port	Inlet & outlet gage port
A / C (UNC)	SAE-12 straight thread / O-ring port: 1-1/16-12 thread	1/2-13 UN	7/16-14 UN	SAE-4 straight thread / O-ring port: 7/16-20 UN thread
B / D (metric)	ISO 6149 straight thread / O-ring port: M27 x 2 thread	M12 x 1,75	M12 x 1,75	ISO 6149 straight thread / O-ring port: M12 x 1,5 thread

eP2105

Pump shown is a CW rotation eP2105 with proportional control valve and swash angle sensor. Dimensions for EC and EF control option are identical.

CCW pump will have inlet and outlet gage port on opposite side of rear cover.

If required by installation the control valve and the swash angle sensor can be positioned at opposite side of the pump. Please consult manufacturer for details.

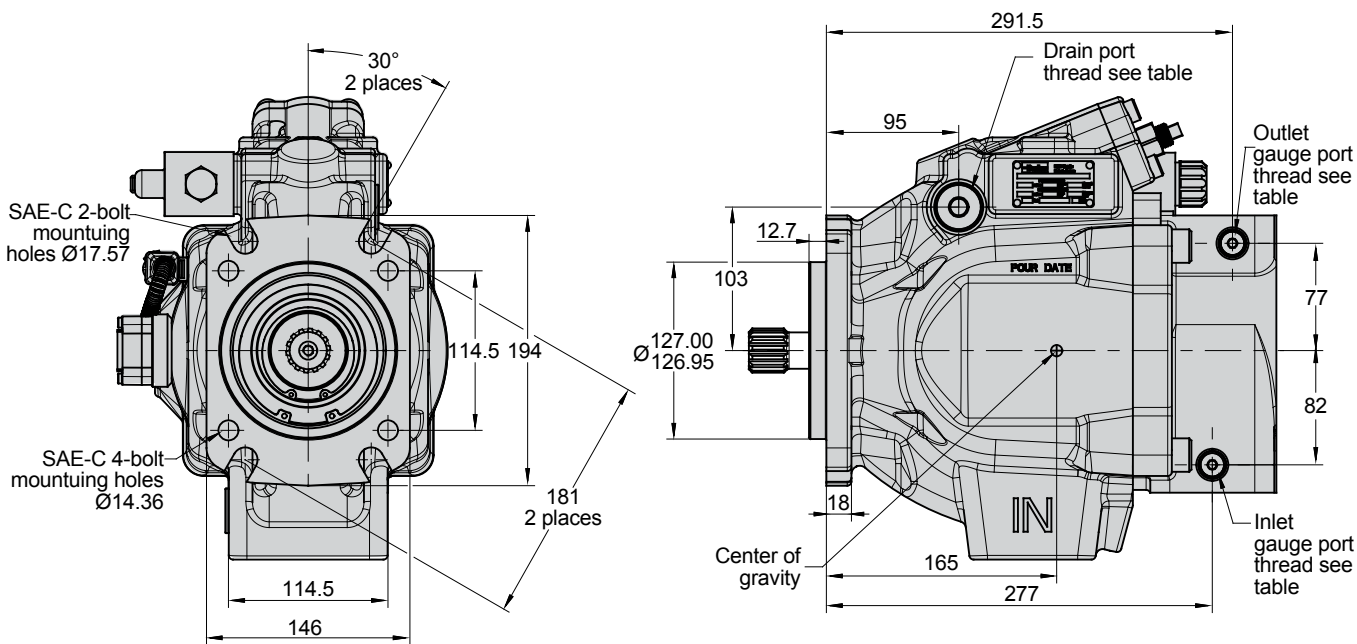

Port & threads option	Drain port	Inlet port	Outlet port	Inlet & outlet gage port
A / C (UNC)	SAE-12 straight thread / O-ring port: 1-1/16-12 thread	1/2-13 UN	1/2-13 UN	SAE-4 straight thread / O-ring port: 7/16-20 UN thread
B / D (metric)	ISO 6149 straight thread / O-ring port: M27 x 2 thread	M12 x 1,75	M12 x 1,75	ISO 6149 straight thread / O-ring port: M12 x 1,5 thread

eP2105

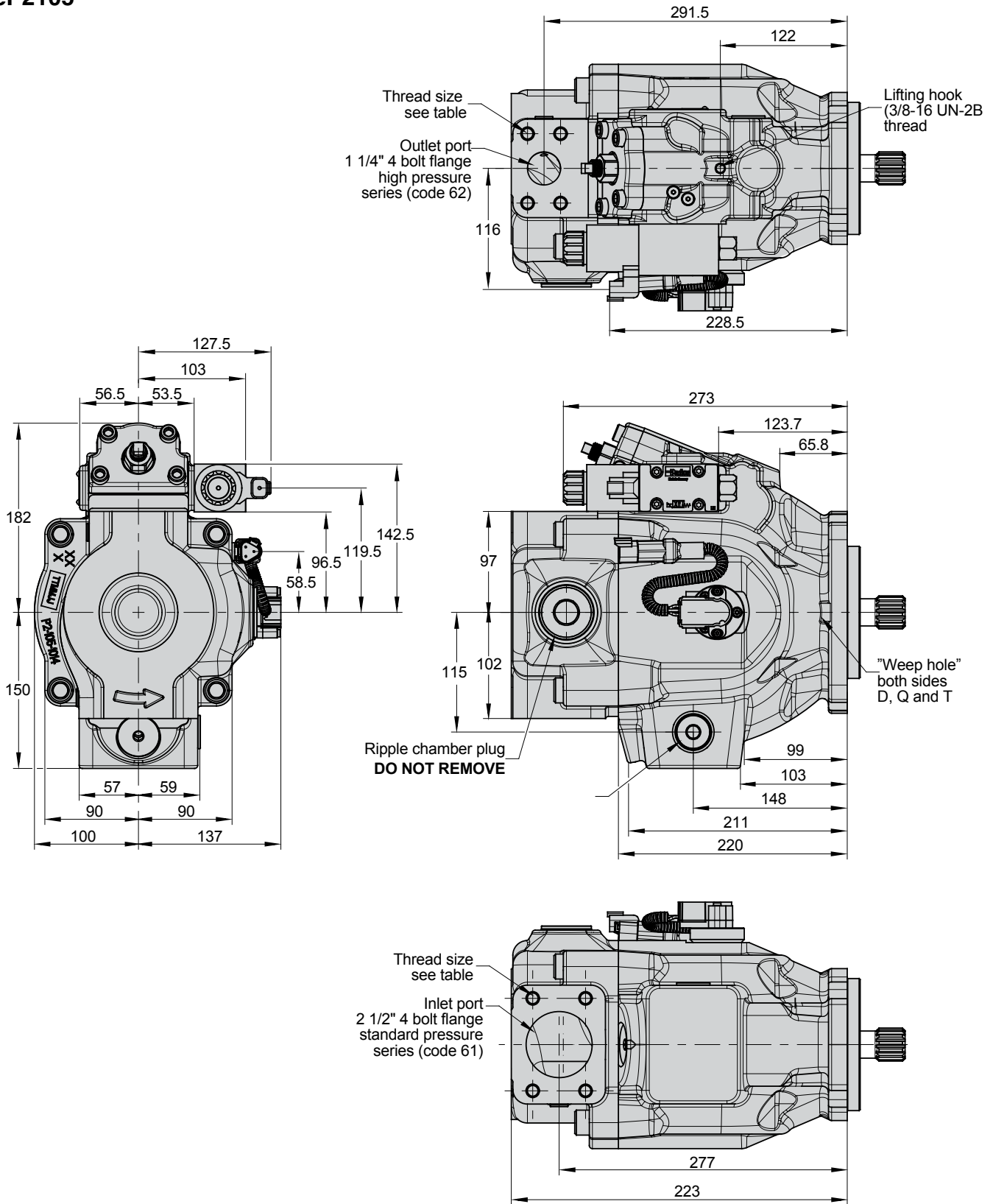

For thru drive dimensions and shaft information please check catalogue **MSG30-2800/UK** (Axial Piston Pumps – Series P2 / P3).

eP2105 w/ pressure sensor

Pump shown is a CW rotation eP2105 with proportional control valve, swash angle sensor and pressure sensor.

Port option C (pump with UNC threads)

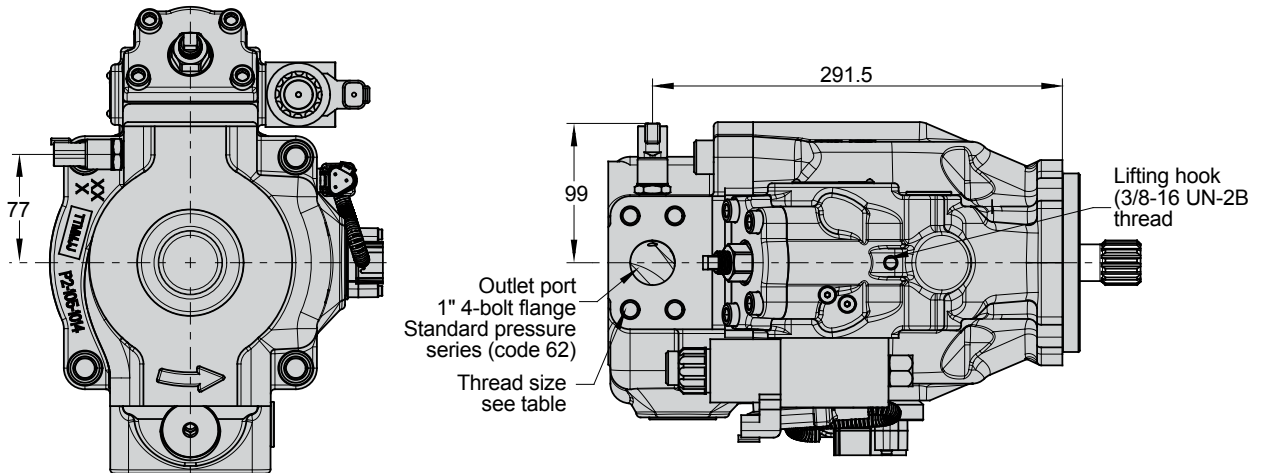

Port option D (pump with metric threads)

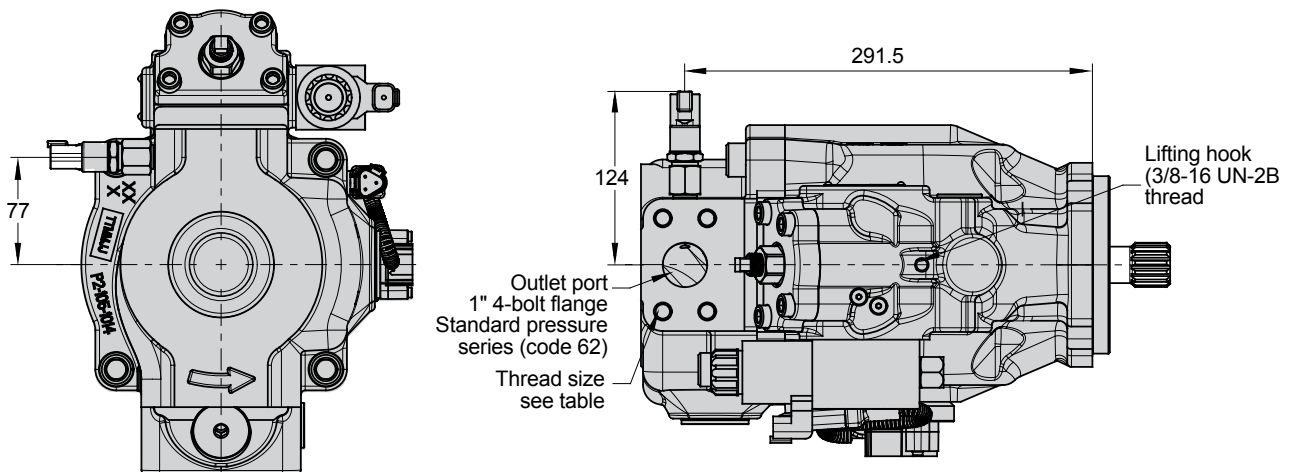

eP2145

Pump shown is a CW rotation eP2145 with proportional control valve and swash angle sensor. Dimensions for EC and EF control option are identical.

CCW pump will have inlet and outlet gage port on opposite side of rear cover.

If required by installation the control valve and the swash angle sensor can be positioned at opposite side of the pump. Please consult manufacturer for details.

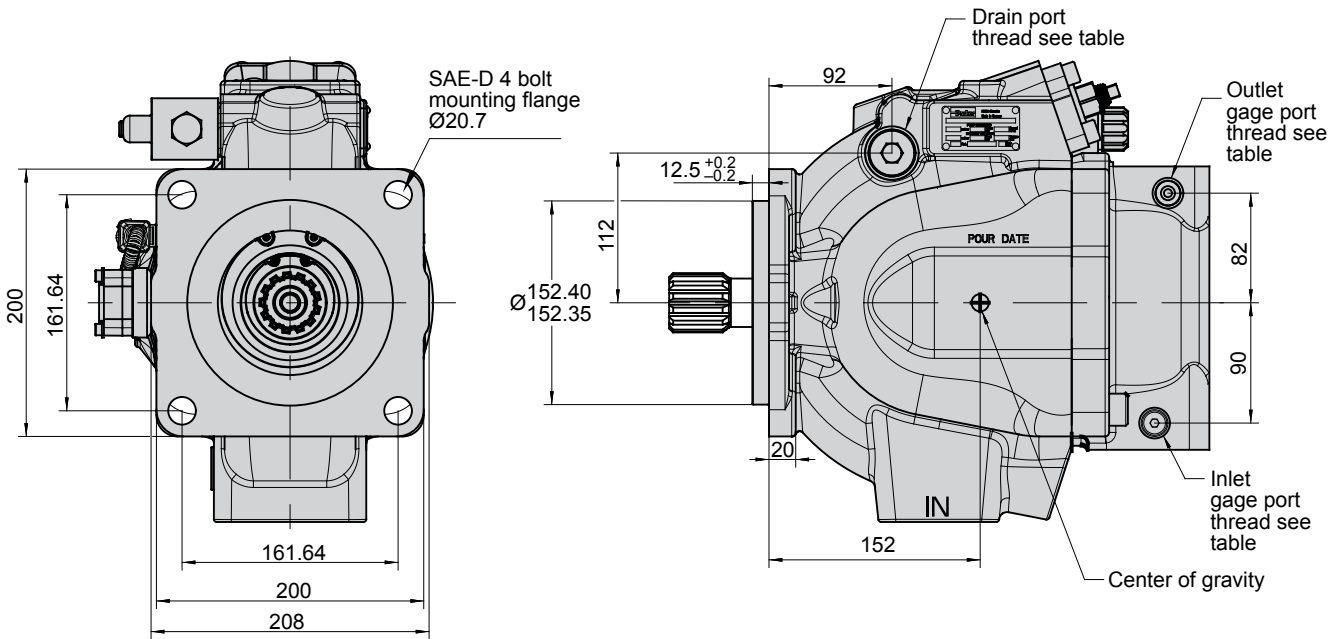

Port & threads option	Drain port	Inlet port	Outlet port	Inlet & outlet gage port
A / C (UNC)	SAE-12 straight thread / O-ring port: 1-1/16-12 thread	1/2-13 UN	1/2-13 UN	SAE-4 straight thread / O-ring port: 7/16-20 UN thread
B / D (metric)	ISO 6149 straight thread / O-ring port: M27 x 2 thread	M12 x 1,75	M12 x 1,75	ISO 6149 straight thread / O-ring port: M12 x 1,5 thread

eP2145

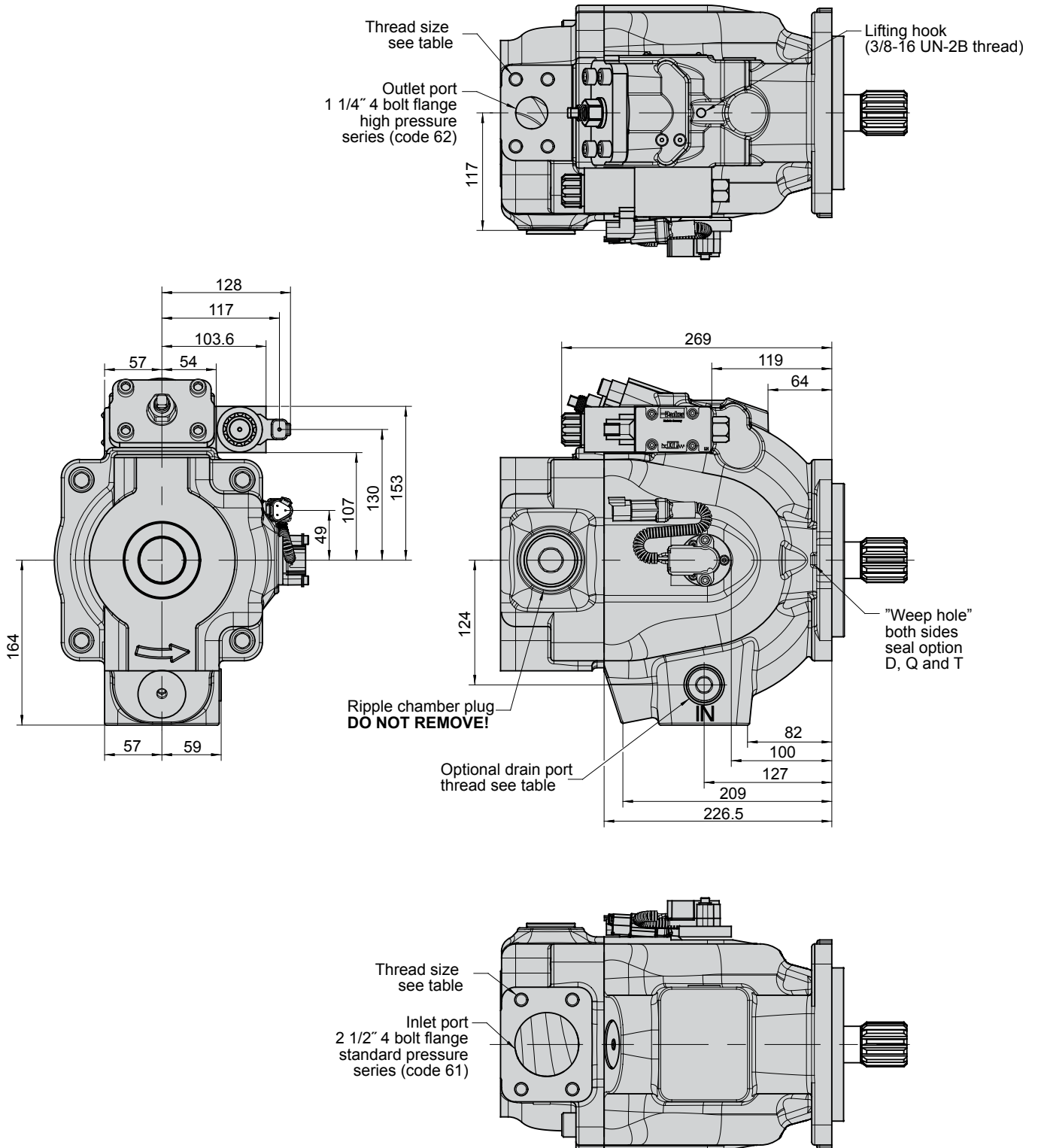

For thru drive dimensions and shaft information please check catalogue **MSG30-2800/UK** (Axial Piston Pumps - Series P2 / P3).

eP2145 w/ pressure sensor

Pump shown is a CW rotation eP2145 with proportional control valve, swash angle sensor and pressure sensor.

Port option C (pump with UNC threads)

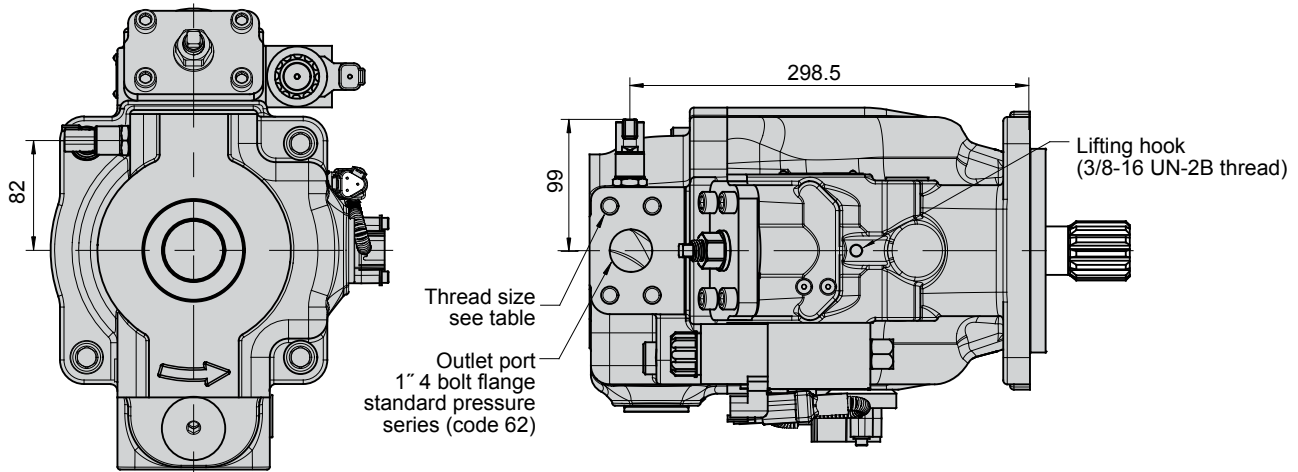

Port option D (pump with metric threads)

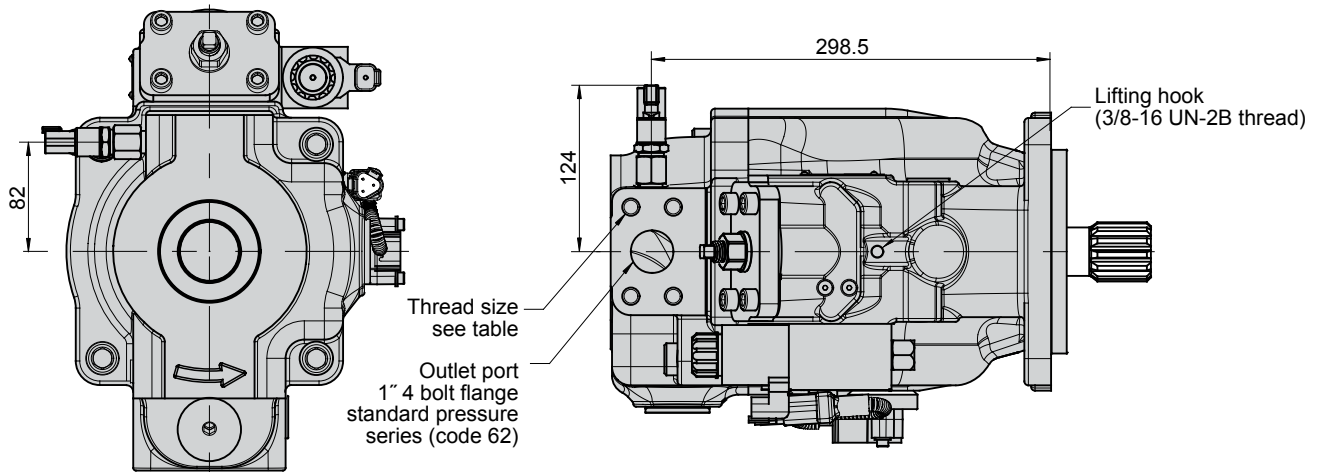

eP3105

Pump shown is a CW rotation eP3105 with proportional control valve and swash angle sensor. Dimensions for EC and EF control option are identical.

CCW pump will have inlet and outlet gage port on opposite side.

If required by installation the control valve and the swash angle sensor can be positioned at opposite side of the pump. Please consult manufacturer for details.

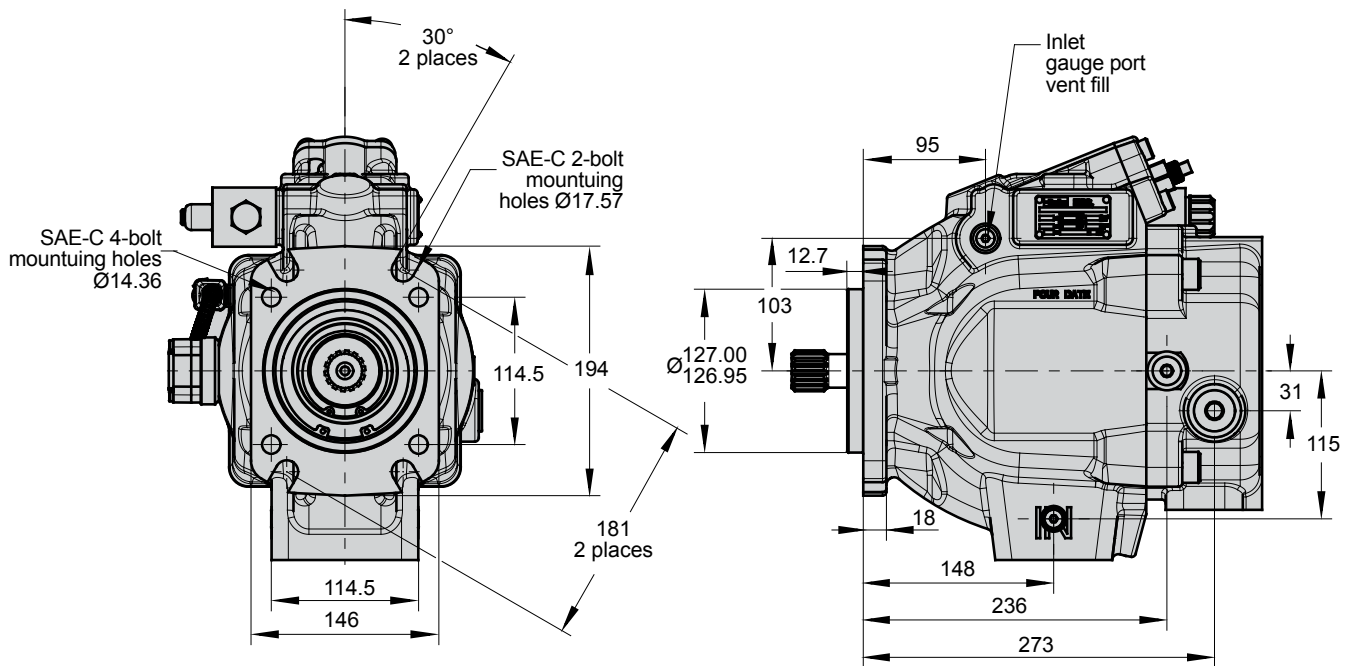

Port & threads option	Drain port	Inlet port	Outlet port	Inlet & outlet gage port
A / C (UNC)	SAE-8 straight thread / O-ring port: 3/4-16 thread	1/2-13 UN	1/2-13 UN	SAE-4 straight thread / O-ring port: 7/16-20 UN thread
B / D (metric)	ISO 6149 straight thread / O-ring port: M18 x 1.5 thread	M12 x 1,75	M12 x 1,75	ISO 6149 straight thread / O-ring port: M12 x 1.5 thread

eP3105

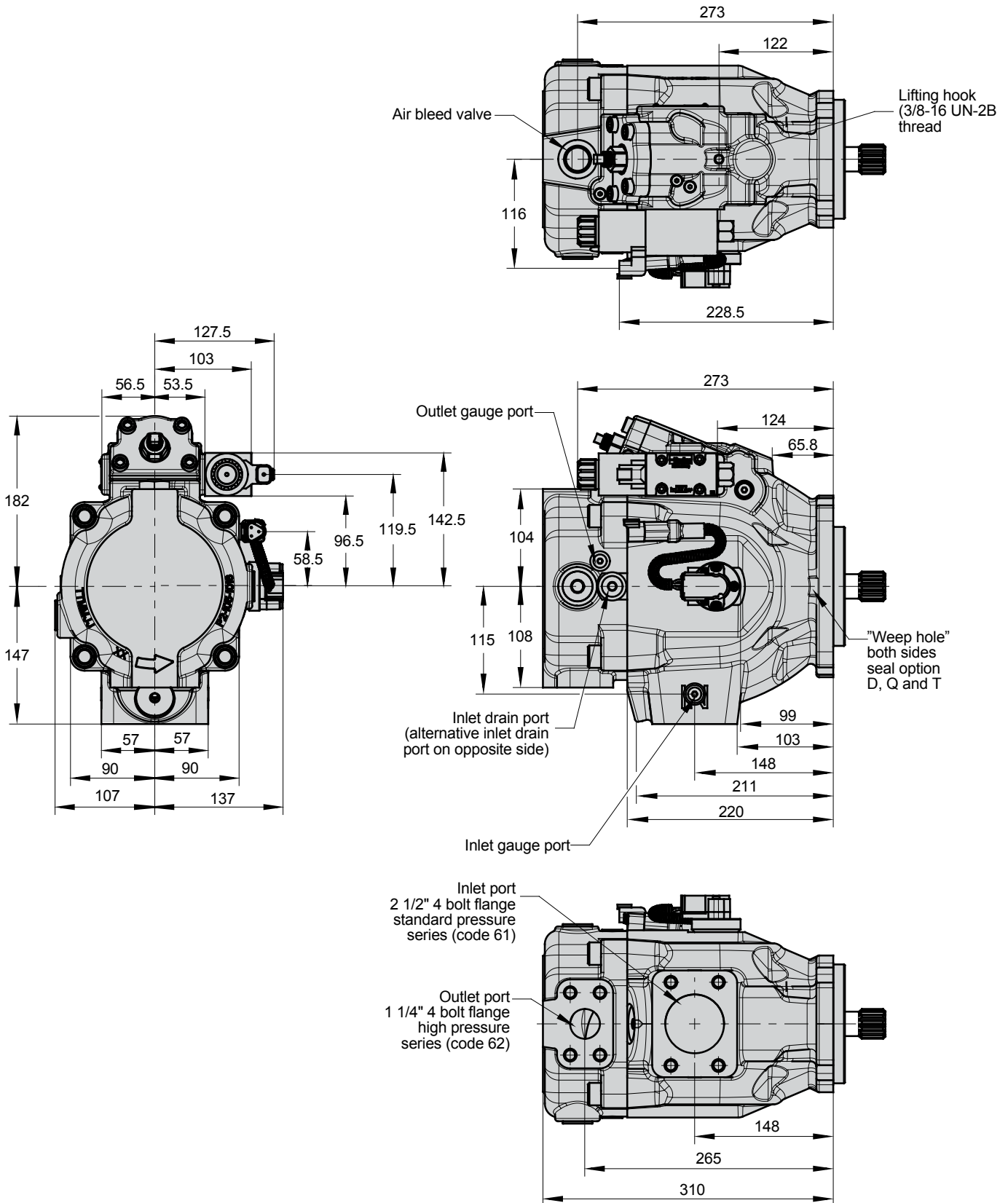

For thru drive dimensions and shaft information please check catalogue **MSG30-2800/UK** (Axial Piston Pumps – Series P2 / P3).

eP3105 w/ pressure sensor

Pump shown is a CW rotation eP3105 with proportional control valve, swash angle sensor and pressure sensor. CCW pump will have inlet and outlet gage port on opposite side.

Port option C (pump with UNC threads)

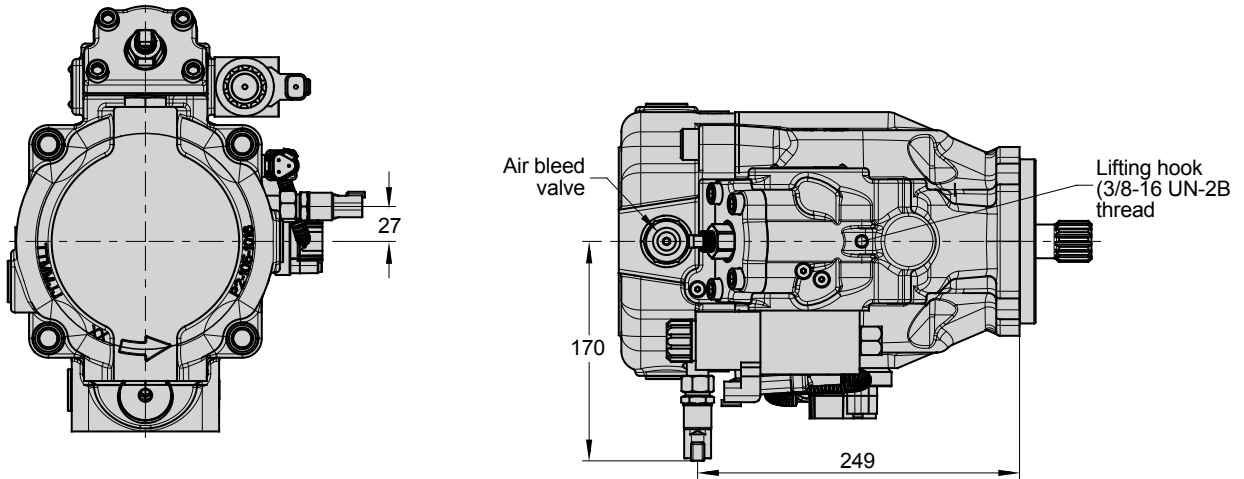

Port option D (pump with metric threads)

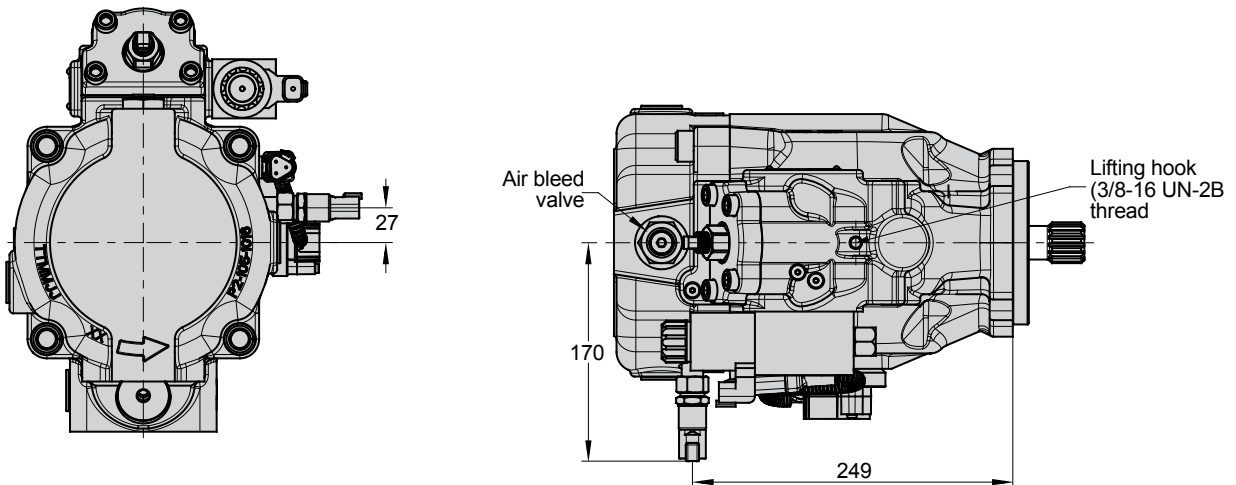

eP3145

Pump shown is a CW rotation eP3145 with proportional control valve and swash angle sensor. Dimensions for EC and EF control option are identical.

CCW pump will have inlet and outlet gage port on opposite side.

If required by installation the control valve and the swash angle sensor can be positioned at opposite side of the pump. Please consult manufacturer for details.

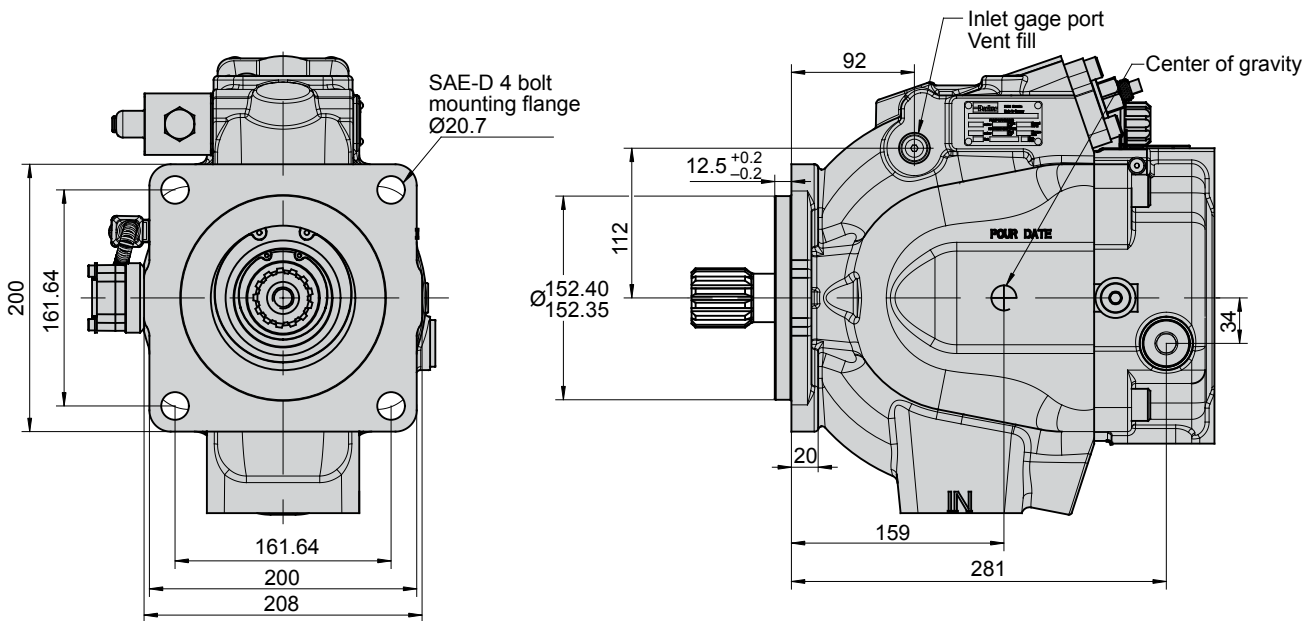

Port & threads option	Drain port	Inlet port	Outlet port	Inlet & outlet gage port
A / C (UNC)	SAE-8 straight thread / O-ring port: 3/4-16 thread	1/2-13 UN	1/2-13 UN	SAE-4 straight thread / O-ring port: 7/16-20 UN thread
B / D (metric)	ISO 6149 straight thread / O-ring port: M18 x 1.5 thread	M12 x 1,75	M12 x 1,75	ISO 6149 straight thread / O-ring port: M12 x 1.5 thread

eP3145

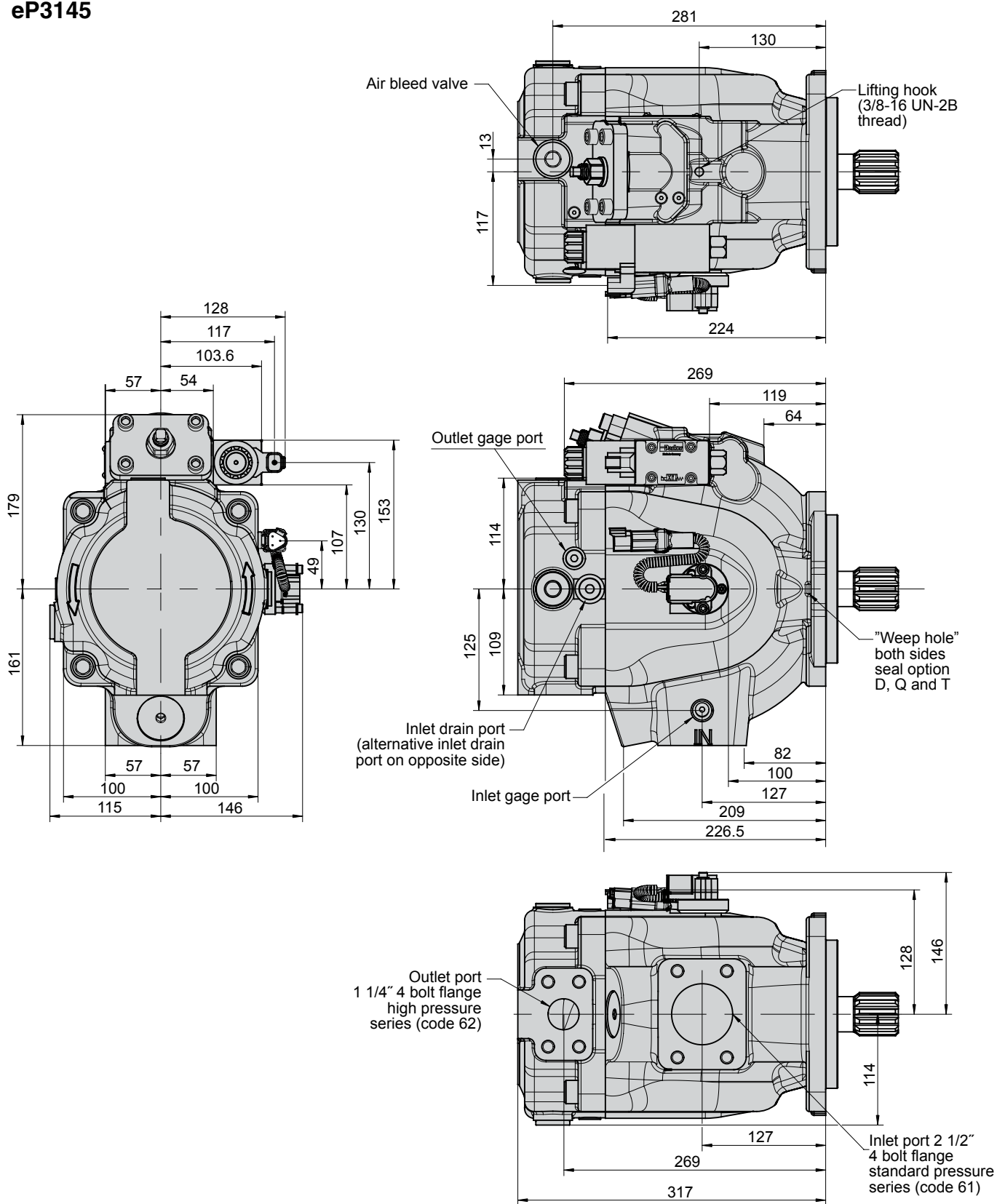

For thru drive dimensions and shaft information please check catalogue **MSG30-2800/UK** (Axial Piston Pumps - Series P2 / P3).

eP3145 w/ pressure sensor

Pump shown is a CW rotation eP3145 with proportional control valve, swash angle sensor and pressure sensor. CCW pump will have inlet and outlet gage port on opposite side.

Port option C (pump with UNC threads)

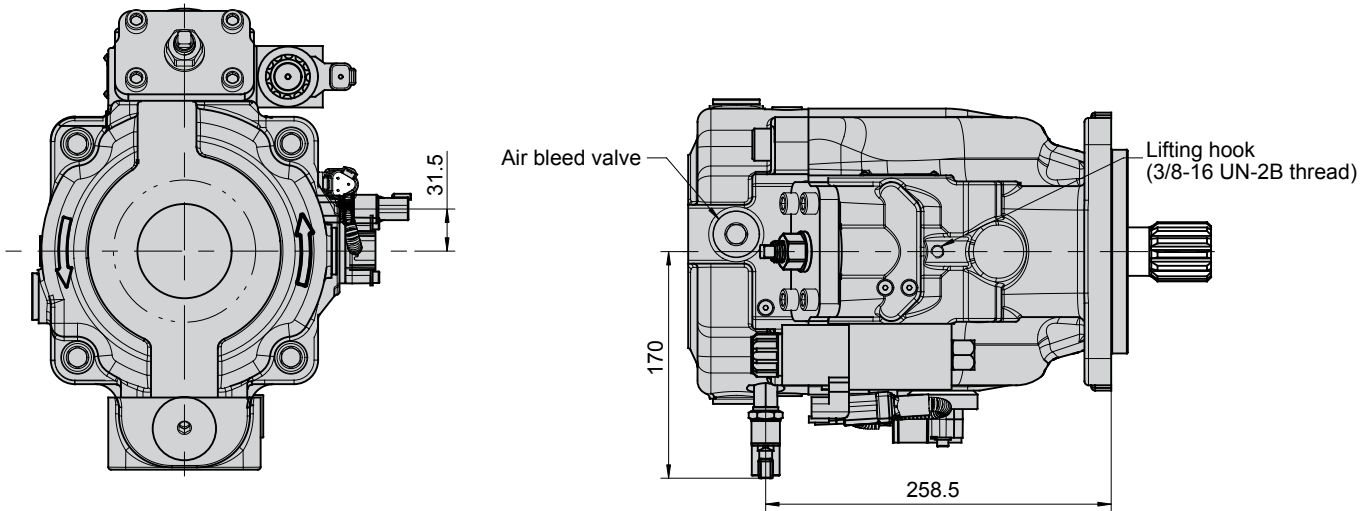

Port option D (pump with metric threads)

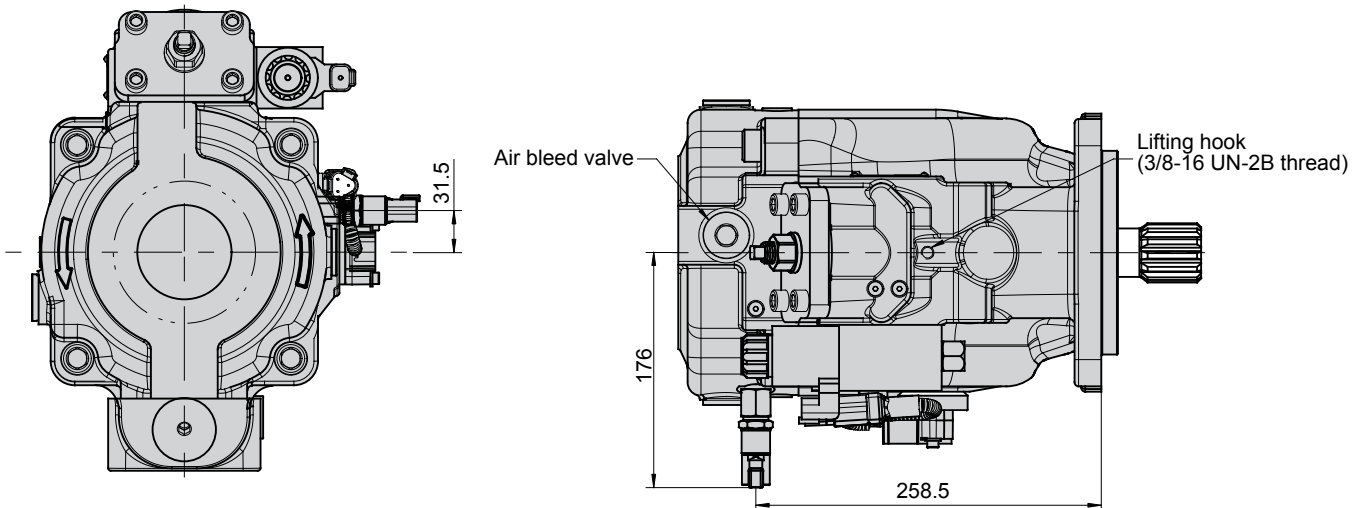

Recommended hydraulic fluids

Hydraulic fluids based on mineral oils acc. to DIN 51524, part 2 and 3 (HLP / HVLP).

Pumps of series P2 / P3 can also be operated with environmentally acceptable (bio-degradable) and synthetic hydraulic fluids. Please consult Parker for further details.

Please check the specification of selected hydraulic fluid for chemical resistance with the pump's sealing material (shaft seal, O-rings).

Hydraulic fluid cleanliness level

For maximum component life and reliability a cleanliness level of 18/16/13 (acc. to ISO 4406) is recommended for eP2 / eP3.

Viscosity

Minimum viscosity for short periods:
10mm²/s (cSt)

Recommended continuous operating viscosity:
[15...40] mm²/s (cSt)

Maximum cold start viscosity:
1000 mm²/s (cSt)

Temperature

Check temperature range of selected seal material and compare with maximum system and ambient temperature.

The following limitations refer to average case drain temperature (measured at drain port), which can be up to 20 °C higher than in the reservoir:

Sealing option	Tmin [°C]	Tmax [°C]
N / D	-25	+80
B / Q	-40	+80
V / T	-25	+80

Shaft Loads

Please strictly follow the instructions of the coupling / PTO supplier regarding axial clearance, axial alignment and angular tolerances. The drive shaft should only carry torque. Units subjected to radial loads require the installation of an outboard bearing. Axial loads are not permitted.

Related Documents

For further information on Installation, start up procedure and trouble shooting please check document **HY30-2901-INST**.



WARNING – USER RESPONSIBILITY

FAILURE OR IMPROPER SELECTION OR IMPROPER USE OF THE PRODUCTS DESCRIBED HEREIN OR RELATED ITEMS CAN CAUSE DEATH, PERSONAL INJURY AND PROPERTY DAMAGE.

This document and other information from Parker-Hannifin Corporation, its subsidiaries and authorized distributors provide product or system options for further investigation by users having technical expertise.

The user, through its own analysis and testing, is solely responsible for making the final selection of the system and components and assuring that all performance, endurance, maintenance, safety and warning requirements of the application are met. The user must analyze all aspects of the application, follow applicable industry standards, and follow the information concerning the product in the current product catalog and in any other materials provided from Parker or its subsidiaries or authorized distributors.

To the extent that Parker or its subsidiaries or authorized distributors provide component or system options based upon data or specifications provided by the user, the user is responsible for determining that such data and specifications are suitable and sufficient for all applications and reasonably foreseeable uses of the components or systems.

Offer of Sale

Please contact your Parker representation for a detailed "Offer of Sale".

Parker Worldwide

Europe, Middle East, Africa

AE – United Arab Emirates, Dubai

Tel: +971 4 8127100
parker.me@parker.com

AT – Austria, Wiener Neustadt

Tel: +43 (0)2622 23501-0
parker.austria@parker.com

AT – Eastern Europe, Wiener Neustadt

Tel: +43 (0)2622 23501 900
parker.easteurope@parker.com

AZ – Azerbaijan, Baku

Tel: +994 50 2233 458
parker.azerbaijan@parker.com

BE/LU – Belgium, Nivelles

Tel: +32 (0)67 280 900
parker.belgium@parker.com

BG – Bulgaria, Sofia

Tel: +359 2 980 1344
parker.bulgaria@parker.com

BY – Belarus, Minsk

Tel: +48 (0)22 573 24 00
parker.poland@parker.com

CH – Switzerland, Etoy

Tel: +41 (0)21 821 87 00
parker.switzerland@parker.com

CZ – Czech Republic, Klecany

Tel: +420 284 083 111
parker.czechrepublic@parker.com

DE – Germany, Kaarst

Tel: +49 (0)2131 4016 0
parker.germany@parker.com

DK – Denmark, Ballerup

Tel: +45 43 56 04 00
parker.denmark@parker.com

ES – Spain, Madrid

Tel: +34 902 330 001
parker.spain@parker.com

FI – Finland, Vantaa

Tel: +358 (0)20 753 2500
parker.finland@parker.com

FR – France, Contamine s/Arve

Tel: +33 (0)4 50 25 80 25
parker.france@parker.com

GR – Greece, Piraeus

Tel: +30 210 933 6450
parker.greece@parker.com

HU – Hungary, Budaörs

Tel: +36 23 885 470
parker.hungary@parker.com

IE – Ireland, Dublin

Tel: +353 (0)1 466 6370
parker.ireland@parker.com

IL – Israel

Tel: +39 02 45 19 21
parker.israel@parker.com

IT – Italy, Corsico (MI)

Tel: +39 02 45 19 21
parker.italy@parker.com

KZ – Kazakhstan, Almaty

Tel: +7 7273 561 000
parker.easteurope@parker.com

NL – The Netherlands, Oldenzaal

Tel: +31 (0)541 585 000
parker.nl@parker.com

NO – Norway, Asker

Tel: +47 66 75 34 00
parker.norway@parker.com

PL – Poland, Warsaw

Tel: +48 (0)22 573 24 00
parker.poland@parker.com

PT – Portugal

Tel: +351 22 999 7360
parker.portugal@parker.com

RO – Romania, Bucharest

Tel: +40 21 252 1382
parker.romania@parker.com

RU – Russia, Moscow

Tel: +7 495 645-2156
parker.russia@parker.com

SE – Sweden, Spånga

Tel: +46 (0)8 59 79 50 00
parker.sweden@parker.com

SK – Slovakia, Banská Bystrica

Tel: +421 484 162 252
parker.slovakia@parker.com

SL – Slovenia, Novo Mesto

Tel: +386 7 337 6650
parker.slovenia@parker.com

TR – Turkey, Istanbul

Tel: +90 216 4997081
parker.turkey@parker.com

UA – Ukraine, Kiev

Tel: +48 (0)22 573 24 00
parker.poland@parker.com

UK – United Kingdom, Warwick

Tel: +44 (0)1926 317 878
parker.uk@parker.com

ZA – South Africa, Kempton Park

Tel: +27 (0)11 961 0700
parker.southafrica@parker.com

North America

CA – Canada, Milton, Ontario

Tel: +1 905 693 3000

US – USA, Cleveland

Tel: +1 216 896 3000

Asia Pacific

AU – Australia, Castle Hill

Tel: +61 (0)2-9634 7777

CN – China, Shanghai

Tel: +86 21 2899 5000

HK – Hong Kong

Tel: +852 2428 8008

IN – India, Mumbai

Tel: +91 22 6513 7081-85

JP – Japan, Tokyo

Tel: +81 (0)3 6408 3901

KR – South Korea, Seoul

Tel: +82 2 559 0400

MY – Malaysia, Shah Alam

Tel: +60 3 7849 0800

NZ – New Zealand, Mt Wellington

Tel: +64 9 574 1744

SG – Singapore

Tel: +65 6887 6300

TH – Thailand, Bangkok

Tel: +662 186 7000

TW – Taiwan, Taipei

Tel: +886 2 2298 8987

South America

AR – Argentina, Buenos Aires

Tel: +54 3327 44 4129

BR – Brazil, Sao Jose dos Campos

Tel: +55 800 727 5374

CL – Chile, Santiago

Tel: +56 2 623 1216

MX – Mexico, Toluca

Tel: +52 72 2275 4200

Ed.: 2018-02-08

EMEA Product Information Centre

Free phone: 00 800 27 27 5374

(from AT, BE, CH, CZ, DE, DK, EE, ES, FI, FR, IE, IL,
IS, IT, LU, MT, NL, NO, PL, PT, RU, SE, SK, UK, ZA)

US Product Information Centre

Toll-free number: 1-800-27 27 537

www.parker.com/pmde

Your local authorized Parker distributor

