

PARKER HANNIFIN CORPORATION
AIRCRAFT WHEEL & BRAKE
AVON, OHIO

PARTS LIST

199-512 SEAL REPAIR KIT FOR
10-30, 10-30A, 10-30C & 10-30D MASTER CYLINDER

<u>PART NUMBER</u>	<u>CODE NO.</u>	<u>DESCRIPTION</u>	<u>QUANTITY</u>
101-00100	101-00100	O-Ring (10-30, 10-30A, 10-30C)	1
101-00800	101-00800	O-Ring (All)	2
101-01100	101-01100	O-Ring (All)	1
095-02600	095-02600	Washer, Stat-o-seal (10-30D)	1
095-01300	095-01300	Wiper, Washer (All)	1
082-02100	082-02100	Spring (All)	1
155-04800	155-04800	Snap Ring (10-30, 10-30A, 10-30C)	1
155-00500	155-00500	Snap Ring (10-30D)	1
155-05000	155-05000	Snap Ring (10-30 & 10-30D)	1

Publication Package (P/N PP199-51200)

199-51200 P/L	-----	Parts List for 199-512 Kit (This Document)	1
CM10-30	-----	Overhaul Instructions for 10-30, 10-30A, 10-30C & 10-30D Master Cylinder Assemblies	1

NOTES:

1. Elastomeric cure date required per ESP3620
2. This Service Kit will overhaul one 10-30, 10-30A, 10-30C, or 10-30D Master Cylinder Assembly
3. CM10-30 Overhaul Instructions for 10-30, 10-30A, 10-30C, & 10-30D Master Cylinder Assemblies is also available on-line at www.clevelandwheelsandbrakes.com

199-512
Rev. NC 03-01-84
Rev. A 05-15-00 (0339-45)
Rev. B 12-09-2003 (0358-40)
Rev. C 01-10-2008 (0378-05)

CM10-30 OVERHAUL INSTRUCTIONS FOR MASTER CYLINDERS

MASTER CYLINDER APPLICABILITY:

P/N's: 10-30, 10-30A, 10-30C, 10-30D

INTRODUCTION:

Refer to IPL, Figure 1 for component identification. A prepackaged kit (199-512) contains the O-rings required for unit overhaul of the above noted master cylinders. For units that have unserviceable wear on the piston rod (3), piston (10), end gland (4), or cylinder body (1), replacement of the complete assembly is recommended in lieu of overhaul.

OVERHAUL:

Overhaul period of each master cylinder is recommended every 1000 hours.

SPECIAL TOOLS: Tools that might not normally be found in a mechanics / technician's toolbox.

- Snap ring pliers (internal and external type) - commercial source
- O-Ring extracting tool – 199-18 Extraction Tool Set, Parker Hannifin Corp., Aircraft Wheel & Brake

DISASSEMBLY: 10-30

Remove unit from aircraft. Remove the snap ring (19), using snap ring pliers. Gently pull the piston rod assembly (2) from the cylinder body (1).

CAUTION: Spring (8) & (11) are under installed load.

Compress the springs (8 & 11) and with snap ring removal tool, carefully remove snap ring (13) that holds spring (11) in place. Release the compressive load slowly and remove bushing (12), spring (11), and piston (10). Remove and discard piston O-ring (5). Remove and discard piston rod O-ring (9). Slide end gland (4) and washer wiper (7) off rod. Discard washer wiper (7). Remove and discard end gland O-rings (5) and (6). Slide spring (8) from piston rod (3). With snap ring removal tool remove the snap ring (14).

DISASSEMBLY: 10-30A

Remove unit from aircraft. Remove the snap ring (19), using snap ring pliers. Gently pull the assembled piston rod (3A) from the cylinder body (1).

CAUTION: Spring (8) & (11) are under installed load.

Compress springs (8 & 11) and with snap ring removal tool, carefully remove snap ring (13) that holds spring (11) in place. Release the compressive load slowly and remove bushing (12), spring (11), and piston (10). Remove and discard piston O-ring (5). Remove and discard piston rod O-ring (9). Slide end gland (4) and washer wiper (7) off rod. Discard washer wiper (7). Remove and discard end gland O-rings (5) and (6). Slide spring (8) off piston rod (3A). Remove check nut (18), clevis (15), flat washer (16) and star washer (17).

DISASSEMBLY: 10-30C

Remove unit from aircraft. Remove the snap ring (19), using snap ring pliers. Gently pull the assembled piston rod (3C) from the cylinder body (1A).

CAUTION: Spring (8A) & (11) are under installed load.

Compress springs (8A & 11) and with snap ring removal tool, carefully remove snap ring (13) that holds spring (11) in place. Release the compressive load slowly and remove bushing (12), spring (11), and piston (10). Remove and discard piston O-ring (5). Remove and discard piston rod O-ring (9). Slide end gland (4) and washer wiper (7) off rod. Discard washer wiper (7). Remove and discard end gland O-rings (5) and (6). Slide spring (8A) off piston rod (3C). Remove check nut (18), clevis (15A), flat washer (16) and star washer (17). Remove screws (21) to remove bracket assemblies (20) from cylinder body (1A).

DISASSEMBLY: 10-30D

Remove unit from aircraft. Remove the snap ring (19), using snap ring pliers.

CAUTION: Spring (8) & (11) are under installed load.

Compress the spring (8) carefully remove snap ring (14) that holds spring (8) with snap ring removal tool. Gently pull the piston rod assembly (2A) from the cylinder body (1B).

CM10-30 OVERHAUL INSTRUCTIONS FOR MASTER CYLINDERS

Insert piston rod (3D) and clamp in support fixture (McMaster Carr # 6325A42). Compress bushing (12A) and spring (11), extract retaining ring (13A). Release the compressive load slowly and remove bushing (12A), spring (11), and piston (10A). Remove and discard piston O-ring (5) and check valve Stat-o-seal (9A). Slide end gland (4A) and washer wiper (7) off rod. Discard washer wiper (7). Remove and discard end gland O-rings (5) and (6).

CLEANING:

Clean all metal parts with filtered Mineral Spirits or equivalent commercially available mineral base solvents. Blow low pressure, clean shop air through all internal passages and ports to ensure they are free of foreign material. Use only clean, dry lint free shop towels, (cloth or paper).

INSPECTION:

Visually inspect all components for wear, scoring, cracks, chips, nicks, burrs, pitting, corrosion, flaws, stripped or scored threads and other obvious signs of damage. Inspect the cylinder body (1) bore area and piston (10) OD for scratches. The piston bore diameter should measure 0.551 inch to 0.553 inch. If piston bore diameters measure larger than 0.553 inch replacement of the complete assembly is suggested. The O-rings may not properly seal in an oversize bore and the performance of the assembly on the aircraft will be compromised. Piston rods (3) that are excessively scratched, bent or have defective threads are to be removed from service.

Measure spring (11) for a minimum free length of 0.490 inch. Measure spring (8) for a minimum free length of 4.55 inch. Measure spring (8A) for a minimum free length of 3.60 inch. Discard bent or corroded springs or if free length is less than minimum specified. Acceptable parts shall be stored in clean plastic covered containers.

REPAIR: Repair is limited to those components listed in **INSPECTION**.

Replace or repair all parts that do not meet requirements. Replace all O-rings. Small scratches may be burnished out with #600 grit or finer, wet or dry aluminum oxide paper. Clean and store acceptable parts as noted above. Treat repaired areas of the aluminum cylinder body with alodine 1200 or equivalent per MIL-C-5541, Class 1A.

REASSEMBLY:

Prior to assembly, coat all O-rings (5), (6), and (9) with Dow Corning 55-O-ring compound to facilitate installation and sealing (not furnished in kit). The installation of O-ring (9) to the piston rod (3), (3A), or (3C) must be accomplished with the aid of an installation bullet (see Figure 3). The bullet, stem, and o-ring must be lubricated with Dow Corning 55 o-ring compound and the seal must be installed with a single rapid stroke to minimize expansion. Lubricate the Stat-o-seal (9A) liberally with o-ring lubricant and slide over piston rod stem in the same manner without using bullet.

CAUTION: Overstretching or creating small scratches will result in a split that will develop into a broken o-ring and loss of pressure.

Apply a coating of hydraulic brake fluid (MIL-H-5606) to bore of cylinder housing. Reassemble in the reverse of disassembly. When installing the end gland (4, 4A), align the gland fluid passage notch with the cylinder ports and install the sharp edge side of the snap rings away from the gland (4, 4A) or bushing (12). Refer to the inset view of IPL Figure 1.

TEST PROCEDURE: Failure of the unit to perform any one of the following tests is cause for rejection.

After assembly, support the unit in an appropriate test fixture. Attach appropriate plumbing, fittings and a pressure gage to the outlet port of the assembly. Service with hydraulic fluid and bleed all air from the assembly.

Actuate the rod manually for full length of stroke a minimum of two [2] times - rod shall return to free length position independently. With rod (3, 3A, or 3C, 3D) in fully relaxed position, connect a pressure source to the outlet port and apply 2 to 10 psi fluid pressure - fluid shall flow freely from the inlet port. Position and restrain rod at approx. ¼ to ½ of the available stroke. Apply proof pressure of 900 psi to the outlet port and hold for 15 seconds - there shall be no leakage from inlet port, from the cylinder body (1 or 1A), or from the rod gland (4, 4A) area. Plug the inlet port and apply 10 to 20 psi to outlet port. Hold for 20 to 30 seconds - there shall be no leakage around the rod or gland area. If cylinder fails to hold pressure or if leakage is seen; disassemble and check O-rings for cuts, scratches, abrasions, dirt or contamination around the O-rings.

CM10-30 OVERHAUL INSTRUCTIONS

ITEM	ASSY	TORQUE SPECIFICATION
NUT (18)	10-30A	35 TO 45 LB-IN (DRY TORQUE)
NUT (18)	10-30C	25 TO 30 LB-IN (DRY TORQUE)
SCREW (21)	10-30C	12 TO 15 LB-IN (DRY TORQUE)
ELBOW (23)	10-30C	FINGER TIGHT PLUS 1 TO 2 TURNS TO OBTAIN ALIGNMENT (DRY TORQUE)
FITTING (24)	10-30C	40 TO 50 LB-IN (DRY TORQUE)

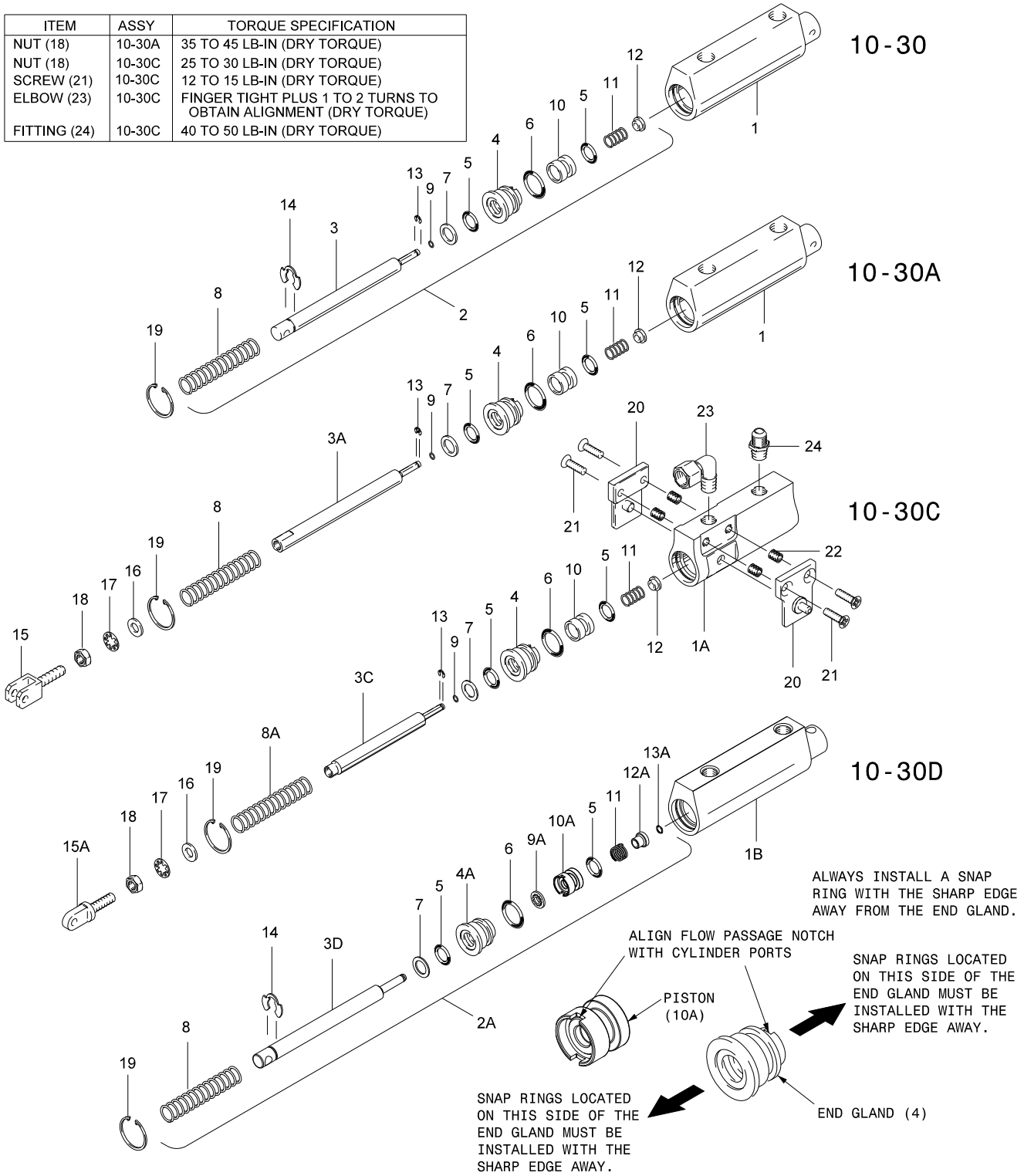

IPL Figure 1

CM10-30 OVERHAUL INSTRUCTIONS

Item No.	Part Number	Description	Qty Per Assembly				
			10-30 (1)	10-30A	10-30C	10-30D	199-512
1	144-03200	Cylinder Body	1	1			
1A	144-12000	Cylinder Body			1		
1B	144-11900	Cylinder Body				1	
2	182-02200	Piston Rod Assembly	1				
2A	182-08500	Piston Rod Assembly				1	
3	142-03900	Piston Rod	1				
3A	142-03700	Piston Rod		1			
3C	142-12000	Piston Rod			1		
3D	142-13700	Piston Rod				1	
4	141-02500	End Gland	1	1	1		
4A	141-09000	End Gland				1	
5	101-00800	O-Ring (MS28775-110)	2	2	2	2	2
6	101-01100	O-Ring (MS28775-113)	1	1	1	1	1
7	095-01300	Wiper Washer	1	1	1	1	1
8	082-14500	Spring	1	1		1	
8A	082-13700	Spring			1		
9	101-00100	O-Ring	1	1	1		1
9A	095-02600	Stat-O-Seal				1	1
10	148-02500	Piston	1	1	1		
10A	148-09200	Piston				1	
11	082-02100	Spring	1	1	1	1	1
12	145-05800	Bushing	1	1	1		
12A	145-01500	Spring Guide				1	
13	155-04800	Snap Ring	1	1	1		1
13A	155-00500	Snap Ring				1	1
14	155-05000	Snap Ring	1			1	1
15	143-00900	Clevis		1			
15A	143-03100	Clevis			1		
16	095-10100	Washer (AN960-616L)		1	1		
17	095-15600	Washer, Star (AN936A416)		1	1		
18	094-03000	Nut, Check (AN316-4)		1	1		
19	155-04700	Snap Ring	1	1	1	1	
20	111-10900	Bracket Assembly			2		
21	102-17500	Screw (MS24694-S49)			4		
22	230-05500	Locking Insert (MS21209F1-15L)			4		
23	104-09300	Elbow, Male			1		
24	104-00300	Tube Fitting (AN816-4D)			1		
	CM10-30	Overhaul Instructions (this document)					1

(1) SB7093-1 Service Bulletin Kit upgrades 10-30 master cylinder to 10-30D configuration per SB7093.

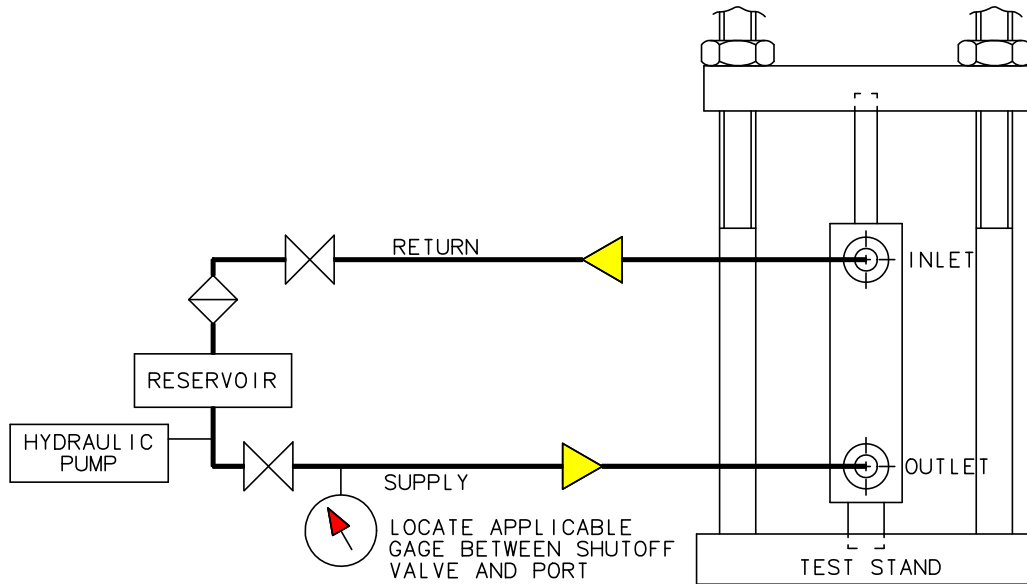

Test Setup - Figure 2

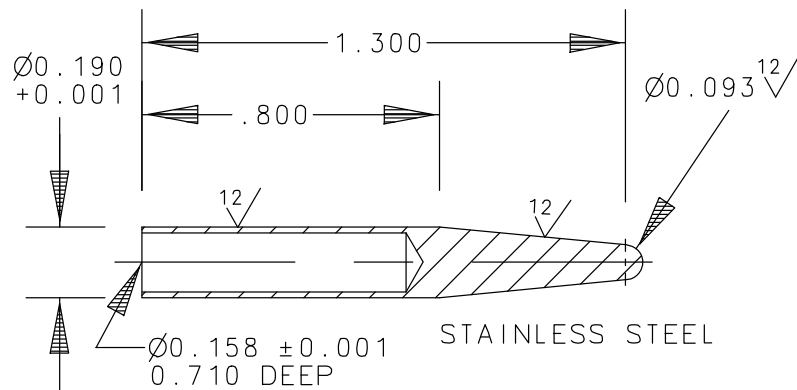

Assembly Bullet – Figure 3