

FUSOR® 123/126 NON-SAG SEAM SEALER (FAST)

Technical Data Sheet

Fusor® 123/126 sealer is a two-component, urethane-based seam sealer used for duplicating factory appearance on truck bed, tooled door skin, floor pan and core support seams.

Fusor 123/126 sealer is used in applications which require a non-sag cosmetic seam sealer with reduced cycle time. Sealer can be applied directly to bare metal or primed surfaces.

Features and Benefits

High Performance: provides excellent adhesion to bare or primed surfaces.

Versatile: bonds bare metal, epoxy or urethane two-component primed surfaces; weld through with minimal burn back.

Excellent Appearance: easily duplicates factory appearance; provides extremely flexible seal with no shrinkage, cracking or sagging.

Environmentally Resistant: provides excellent corrosion protection.

Easy to Finish: can be tooled, wiped clean, sanded and/or painted immediately.

Application

Prepare: Clean the area to be sealed with Fusor 703 adhesion prep/cleaner.

If sealing bare metal, scuff-sand metal with 80-120 grit sandpaper until shiny in appearance.

If sealing painted or primed surface, prime the surface using a two-component catalyzed epoxy or urethane primer. Ensure applied primer has cured according to manufacturer's recommendations, then lightly scuff-sand paint or primer. Re-clean the area to be sealed with Fusor adhesion prep/cleaner.

Note: Do not use acid-etch primers as this may inhibit the curing characteristics of the product.

Apply: Load the cartridge into the applicator and remove the end cap. Level the plungers by expelling a small amount of sealer to ensure that material is coming out of both sides of the cartridge. Attach mixing tip and dispense a small amount of sealer to verify the material is evenly mixed and the color is consistent.

Apply sealer to the seam in a continuous bead (see Figure 1). If tooling is required, shape the bead within 3 minutes after sealer application.

Note: Various applications, cleaners/solvents and coatings may not be compatible with this product and should be tested by the user before proceeding with intended repair procedure.

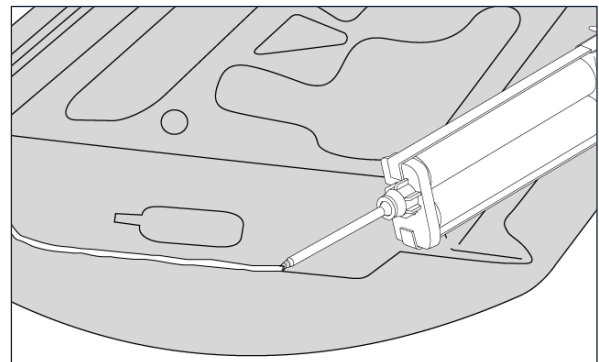

Figure 1. Apply Sealer in Continuous Bead

Typical Properties*

Appearance	White Paste
Base Chemistry	Urethane
Work Time	3 minutes @ 70°F (21°C)
Paint Time**	10 minutes @ 70°F (21°C)
Cure Time	24 hours @ 70°F (21°C)

*Data is typical and not to be used for specification purposes.

** Paint within 24 hours or scuff before painting.

Finish: Prime and paint per manufacturer's recommendations within 24 hours. After 24 hours, lightly scuff.

For more application information, refer to www.Parker.com/APS for standard operating procedures or application training videos.

Shelf Life/Storage

Shelf life is 24 months from date of manufacture when stored at 75°F (24°C) in original, unopened container.

Cautionary Information

Before using this or any Parker Lord product, refer to the Safety Data Sheet (SDS) and label for safe use and handling instructions.

For industrial/commercial use only. Must be applied by trained personnel only. Not to be used in household applications. Not for consumer use.

Fusor® Repair Products Lifetime Guarantee*

LORD Assembly & Protection Solutions Division of Parker-Hannifin Corporation ("Parker Lord") guarantees to the user that Fusor® Repair Products (adhesives, primers, seam sealers and foams only), when used in strict accordance with Parker Lord application and use instructions, will provide a durable repair for the life of the vehicle per the product's technical data sheet. The user is solely responsible for determining the Fusor product and application method for the repair. Application and product guidance can be found on Fusor.com.

THIS EXPRESS WARRANTY IS MADE IN LIEU OF AND EXCLUDES ANY AND ALL OTHER WARRANTIES, EXPRESS OR IMPLIED, BY OPERATION OF LAW OR OTHERWISE, INCLUDING THE IMPLIED WARRANTIES OF MERCHANTABILITY AND FITNESS FOR A PARTICULAR PURPOSE.

Parker Lord shall not be liable under any circumstance for any liability, loss, damage or expense directly or indirectly arising from the application and use of Fusor Products sold hereunder or from any other cause. Parker Lord shall not be liable under any circumstances for consequential, indirect or special damages. **PARKER LORD'S LIABILITY FOR BREACH OF WARRANTY HEREUNDER IS IN ALL INSTANCES LIMITED SOLELY AND EXCLUSIVELY TO THE REASONABLE COSTS OF REPAIR AND/OR REPLACEMENT OF THE BONDED COMPONENTS OF THE VEHICLE.**

This guarantee shall only apply to the above referenced Fusor products sold by Parker Lord on or after January 1, 2001.

Fusor Metal Bonding Adhesives shall only be used for the adhesive-only bonding (no welds or rivets) of metal to metal assemblies (steel or aluminum) in full or partial panel replacements of door skins, roof skins, quarter panels, rear body panels and other outer body sheet metal where approved by the vehicle manufacturer.

Fusor products shall not be used for adhesive-only bonding of any structural component unless specifically recommended by the vehicle manufacturer. Structural panels must be replaced in strict compliance with vehicle manufacturer guidelines. If in doubt as to what is a structural component or the proper installation method, contact the vehicle manufacturer. Further, any Fusor products used in marine composite repair, such as with personal water craft and the like, shall be limited to repairs above the water line.

Parker Lord Engineered Materials Group

111 LORD Drive
Cary, NC 27511-7923
USA
phone +1 877 275-5673
www.parker.com/APS

DS6202 OD 10/24 Rev.4

Information and specifications subject to change without notice and without liability therefor. Trademarks used herein are the property of their respective owners.

© 2024 Parker Hannifin Corporation



Durability Performance*

Lap Shear Strength GM 9751 P	
E-coated Steel	2100 psi (14.4 MPa)
Torsional Impact Resistance GM 9751 P	
E-coated Steel	Coating failure; 98 in-lb (10.88 N-m)
Elongation	166%
Young's Modulus	187 psi (1.29 MPa)

*Data is typical and not to be used for specification purposes.

If you have any questions or need to receive proper use instructions, contact the Parker Lord Customer Support Center at +1 800 234 Fusor (3876) or visit Fusor.com.

To comply with the requirements of the Fusor Repair Products Lifetime Guarantee, attach a copy of this completed page to the repair record, and retain with your files:

Vehicle Make/Model: _____

Vehicle Identification Number: _____

Fusor Product(s) Used for Repair: _____

Lot Number(s) on Cartridge(s) Used for Repair: _____

**This guarantee is void if product is used after the date printed on the cartridge label. Parker Lord Terms and Conditions of Sale shall apply to all sales of Fusor products.*



Continuing Automotive
Service Education
CERTIFIED TRAINING PROVIDER

Values stated in this document represent typical values as not all tests are run on each lot of material produced. For formalized product specifications for specific product end uses, contact the Customer Support Center.

Information provided herein is based upon tests believed to be reliable. In as much as Parker Lord has no control over the manner in which others may use this information, it does not guarantee the results to be obtained. In addition, Parker Lord does not guarantee the performance of the product or the results obtained from the use of the product or this information where the product has been repackaged by any third party, including but not limited to any product end-user. Nor does the company make any express or implied warranty of merchantability or fitness for a particular purpose concerning the effects or results of such use.

WARNING — USER RESPONSIBILITY. FAILURE OR IMPROPER SELECTION OR IMPROPER USE OF THE PRODUCTS DESCRIBED HEREIN OR RELATED ITEMS CAN CAUSE DEATH, PERSONAL INJURY AND PROPERTY DAMAGE.

This document and other information from Parker-Hannifin Corporation, its subsidiaries and authorized distributors provide product or system options for further investigation by users having technical expertise.

The user, through its own analysis and testing, is solely responsible for making the final selection of the system and components and assuring that all performance, endurance, maintenance, safety and warning requirements of the application are met. The user must analyze all aspects of the application, follow applicable industry standards, and follow the information concerning the product in the current product catalog and in any other materials provided from Parker or its subsidiaries or authorized distributors.

To the extent that Parker or its subsidiaries or authorized distributors provide component or system options based upon data or specifications provided by the user, the user is responsible for determining that such data and specifications are suitable and sufficient for all applications and reasonably foreseeable uses of the components or systems.