



---

**CE**

**ViX250AH & ViX500AH  
Digital Servo Drive  
User Guide**

# IMPORTANT INFORMATION FOR USERS

## Installation and Operation of Motion Control Equipment

It is important that motion control equipment is installed and operated in such a way that all applicable safety requirements are met. It is your responsibility as an installer to ensure that you identify the relevant safety standards and comply with them; failure to do so may result in damage to equipment and personal injury. In particular, you should study the contents of this user guide carefully before installing or operating the equipment.

The installation, set-up, test and maintenance procedures given in this User Guide should only be carried out by competent personnel trained in the installation of electronic equipment. Such personnel should be aware of the potential electrical and mechanical hazards associated with mains-powered motion control equipment - please see the safety warning below. The individual or group having overall responsibility for this equipment must ensure that operators are adequately trained.

Under no circumstances will the suppliers of the equipment be liable for any incidental, consequential or special damages of any kind whatsoever, including but not limited to lost profits arising from or in any way connected with the use of the equipment or this user guide.



### SAFETY WARNING

High-performance motion control equipment is capable of producing rapid movement and very high forces. Unexpected motion may occur especially during the development of controller programs. **KEEP WELL CLEAR** of any machinery driven by stepper or servo motors. Never touch any part of the equipment while it is in operation.

This product is sold as a motion control component to be installed in a complete system using good engineering practice. Care must be taken to ensure that the product is installed and used in a safe manner according to local safety laws and regulations. In particular, the product must be enclosed such that no part is accessible while power may be applied.

This and other information from Parker-Hannifin Corporation, its subsidiaries and authorised distributors provides product or system options for further investigation by users having technical expertise. Before you select or use any product or system, it is important that you analyse all aspects of your application and review the information concerning the product in the current product catalogue. The user, through its own analysis and testing, is solely responsible for making the final selection of the system and components and assuring that all performance, safety and warning requirements of the application are met.

If the equipment is used in any manner that does not conform to the instructions given in this user guide, then the protection provided by the equipment may be impaired.

The information in this user guide, including any apparatus, methods, techniques, and concepts described herein, are the proprietary property of Parker Electromechanical Division or its licensors, and may not be copied, disclosed, or used for any purpose not expressly authorised by the owner thereof.

Since Parker Electromechanical constantly strives to improve all of its products, we reserve the right to modify equipment and user guides without prior notice. No part of this user guide may be reproduced in any form without the prior consent of Parker Electromechanical Division.

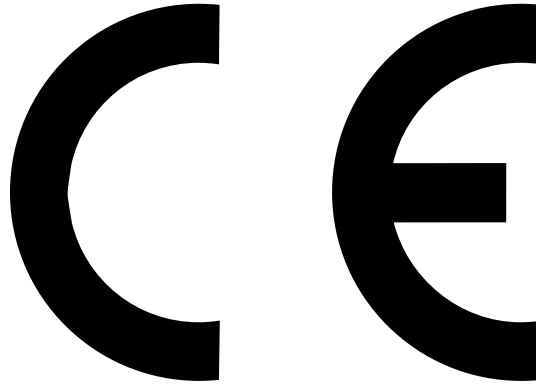

**Product Type:** ViX250AH, ViX500AH

**The above product is in compliance with the requirements of directives**

- **73/23/EEC**                      **Low Voltage Directive**
- **93/68/EEC**                    **CE Marking Directive**
- **89/336/EEC**                  **Electromagnetic Compatibility Directive**

Provided the installation requirements described in this user guide are met, and there are no special requirements of the installation and operating environment so that the application may be considered typical, the ViX servo drive series installation will conform to the protection requirements of Council Directive 89/336/EEC as amended by Directive 92/31/EEC on the approximation of the laws of the Member States relating to Electromagnetic Compatibility when operated and maintained as intended.

In assessing the overall compliance of an installation consideration must also be given to the effects of mains harmonics and flicker when interfacing the total supply system to the public low voltage supply system.

In accordance with IEC 61800-3:1997 (Adjustable speed electrical power drive systems) this product is of the restricted sales distribution class which meets the needs of an industrial environment when installed as directed. However, further measures may need to be taken for use of the product in a domestic environment.

Compliance is demonstrated by the application of the following standards:

BS EN 61800-3 (1997) including Amendment A11	Adjustable speed electrical power drive systems Part 3. EMC product standard including specific test methods
BS EN 61000-6-2 (2001)	Electromagnetic compatibility – Part 6-2: Generic standards Immunity for industrial environments
BS EN 61000-6-4 (2001)	Electromagnetic compatibility – Part 6-4: Generic standards – Emission standard for industrial environments
BS EN 61010-1 (1993) including Amendment A2	Safety requirements for electrical equipment for measurement, control, and laboratory use. Part 1. General requirements

**WARNING – Risk of damage and/or personal injury**

**The ViX drives described in this user guide contain no user-serviceable parts. Attempting to open the case of any unit, or to replace any internal component, may result in damage to the unit and/or personal injury. This may also void the warranty.**

# Contact Addresses

---

**For engineering  
assistance in Europe:**

**Parker Hannifin plc  
Electromechanical  
Division - Digiplan**

21 Balena Close  
Poole, Dorset  
England, BH17 7DX  
Tel: +44 (0)1202-699000  
Fax: +44 (0)1202-695750  
e-mail: sales.digiplan@parker.com  
e-mail: support.digiplan@parker.com  
Website: www.parker-emd.com

**For engineering  
assistance in Italy  
Parker Hannifin SpA  
Divisione SBC**

20092 Cinisello Balsamo  
Milan,  
Italy Via Gounod, 1

Tel: +39 02 6601 2478  
Fax: +39 02 6601 2808

e-mail: sales.sbc@parker.com  
Website: www.parker-emd.com

**For engineering  
assistance in Germany**

**Parker Hannifin GmbH  
Electromechanical  
Division - Hauser**

P. O. Box: 77607-1720  
Robert-Bosch-Str. 22  
D-77656 Offenburg, Germany  
Tel: +49 (0)781 509-0  
Fax: +49 (0)781 509-176  
e-mail: sales.hauser@parker.com  
e-mail: techhelp\_emd\_OG@parker.com  
Website: www.parker-emd.com

**For engineering  
assistance in the U.S.:**

**Parker Hannifin Corporation  
Compumotor Division**

5500 Business Park Drive, Suite D  
Rohnert Park  
CA 94928  
USA

Tel: (800) 358-9070  
Fax: (707) 584-3793  
FaxBack System: (800) 936-6939  
e-mail: CMR\_help@parker.com  
Website: www.compumotor.com

---

Symbols used, have the following meanings:



Caution -  
Refer to the  
accompanying documentation

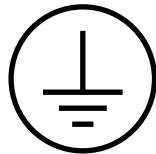

Protective conductor terminal

---

## Contents

---

1. Introduction.....	1
2. Mechanical Installation .....	5
3. Electrical Installation.....	9
4. Control of ViX Drives .....	49
5. EASI-V Software .....	69
6. Command Reference .....	85
7. ViX Maintenance and Troubleshooting .....	105
8. Hardware Reference .....	111
Appendix A.....	115
Appendix B .....	117
Index.....	119

The ViX250AH/500AH Intelligent Digital Servo Drive is UL-Recognised under file E194158. This means it may be incorporated into end-user products that may be eligible for UL Listing, Classification or Certification.



### User Guide Issue Change Summary

This user guide, version 1600.320.01, is the first version of the ViX250AH/ViX500AH Digital Servo Drive.

When a user guide is updated, the new or changed text is differentiated with a change bar in the outside margin (this paragraph is an example). If an entire section is changed, the change bar is located on the outside margin of the section title. For the latest (most up-to-date) changes required by this issue of user guide see the **Latest Changes Sheet** over the page.

---

## Latest Changes Sheet

---

This page lists important changes occurring immediately before publication or between issue updates:

## 1. Introduction

### Product Description

Available in two power ranges, these digital servos use field-oriented control technology to give enhanced dynamic performance with improved efficiency. Housed within an extremely compact case, the drives are suitable for either direct panel or DIN rail mounting.

Using full PWM control with sinusoidal commutation, the two versions of power stage can have continuous current ratings of 2.5A and 5A at motor bus voltages up to 80V. Having high resolution encoder feedback, the drives may be used with a wide range of 3-phase linear and rotary servo motors of different pole counts.

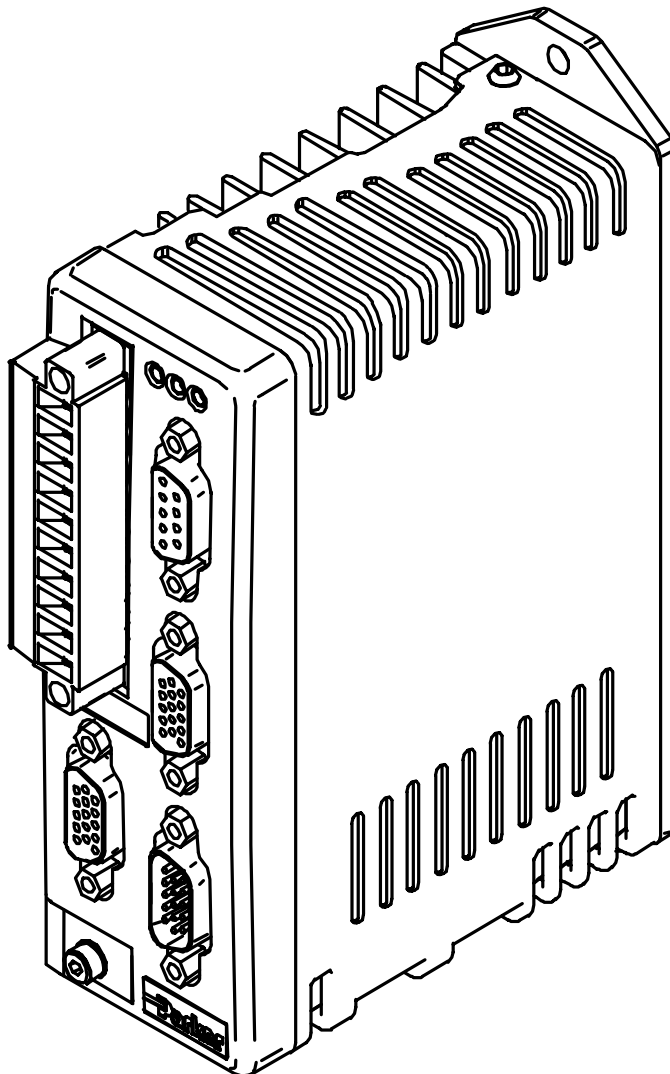

Figure 1-1. ViX250/ViX500 Digital Servo Drive

### Product Variants

Digital servo drives are available in two power versions. Table 1-1 lists the possible combinations:

<b>Product Code</b>	<b>Description</b>
ViX250AH	250VA Servo with high resolution encoder feedback
ViX500AH	500VA Servo with high resolution encoder feedback

**Table 1-1. ViX250/ViX500 Digital Servo Drive Options**

### Product Features

#### Protection Circuits

- Motor short circuits
- Over-voltage
- Under-voltage
- Drive/motor Over-temperature
- 24V reverse supply protection
- Commutation encoder fault
- I<sup>2</sup>t protection

#### Function Indicators

- Drive Status/Feedback Fault (HV/FB)
- Drive Fault (DF)

#### Outputs and Inputs

- 1 Brake input
  - 1 Brake output
  - 1 Analogue monitor output
-



## Fit Kits

Two fit kits are available for ViX drives:

1. VIX-KIT required if you do not purchase motor cables
2. VIX-KIT-NFB required if you do purchase motor cables

VIX-KIT		
Part Number	Quantity	Description
1650.937.01	1	Information sheet
5004.023	1	plastic bag
5006.211	1	Product label
0405.811	1	10-way Flange plug strip
0405.961	1	9-way D-type plug
0405.962	2	15-way HD D-type plug
0405.963	1	15-way HD D-type socket
0409.530	4	9-way D-type cover
0313.020	1	H8FE1115NC ferrite sleeve
4005.218	1	3:1 heatshrink 19mm diam.
4216.101	1	Closed P-clip 9mm ID
4216.102	1	Closed P-clip 10.7mm ID
4216.103	1	Closed P-clip 12.3mm ID

VIX-KIT-NFB		
Part Number	Quantity	Description
1650.937.01	1	Information sheet
5004.023	1	plastic bag
5006.211	1	Product label
0405.811	1	10-way Flange plug strip
0405.961	1	9-way D-type plug
0405.962	1	15-way HD D-type plug
0405.963	1	15-way HD D-type socket
0409.530	3	9-way D-type cover

### **Further Information**

This user guide contains all the necessary information for the effective use of this drive. However, to gain a more in-depth understanding of drive applications and motion control, consider attending one of our world-wide Customer Specific Training Workshops. Details of European based courses are on our web site ([www.parker-emd.com](http://www.parker-emd.com)) under Sales & Services, Training.

Examples of previous courses that have proved to be of benefit include:

- Use and programming of the DIN rail H & L series drives
  - PDFX training
  - Using the 6K controller
  - EASI Tools programming
  - Mechanical product training for ET/ER, XR and HPLA
-

## 2. Mechanical Installation

---

### Installation Requirements

#### Environment

ViX drives operate in a temperature range of 0° to 40°C with natural convection, or 50°C Max with forced-air cooling (see Hardware Reference), at normal levels of humidity (5-95% non-condensing). The drives can tolerate atmospheric pollution degree 2, which means only dry, non-conductive pollution is acceptable.

#### Drive Cooling

Cooling of all drive types is by natural convection up to 40°C. To assist cooling, drives should be installed vertically in an area where there is at least a 50mm (minimum) air gap above and below the package and a 10mm (minimum) gap either side. Avoid mounting heat-producing equipment directly below a drive.

Installers must ensure that the air temperature entering the drive or rising up to the drive is within the ambient temperature restrictions. Under normal use the air temperature leaving the drive and heatsink may be 25°C above ambient.

In the final installation, check that the ambient temperature specification of 40°C Max (without forced air cooling) is not exceeded directly below the top-most drives and that any circulating air flow is not being blocked from reaching the drives. For cabinet cooling calculations, allow 20W per drive.

### Drive Dimensions

ViX250 and ViX500 drives share the same dimensions, shown in Figure 2-1.

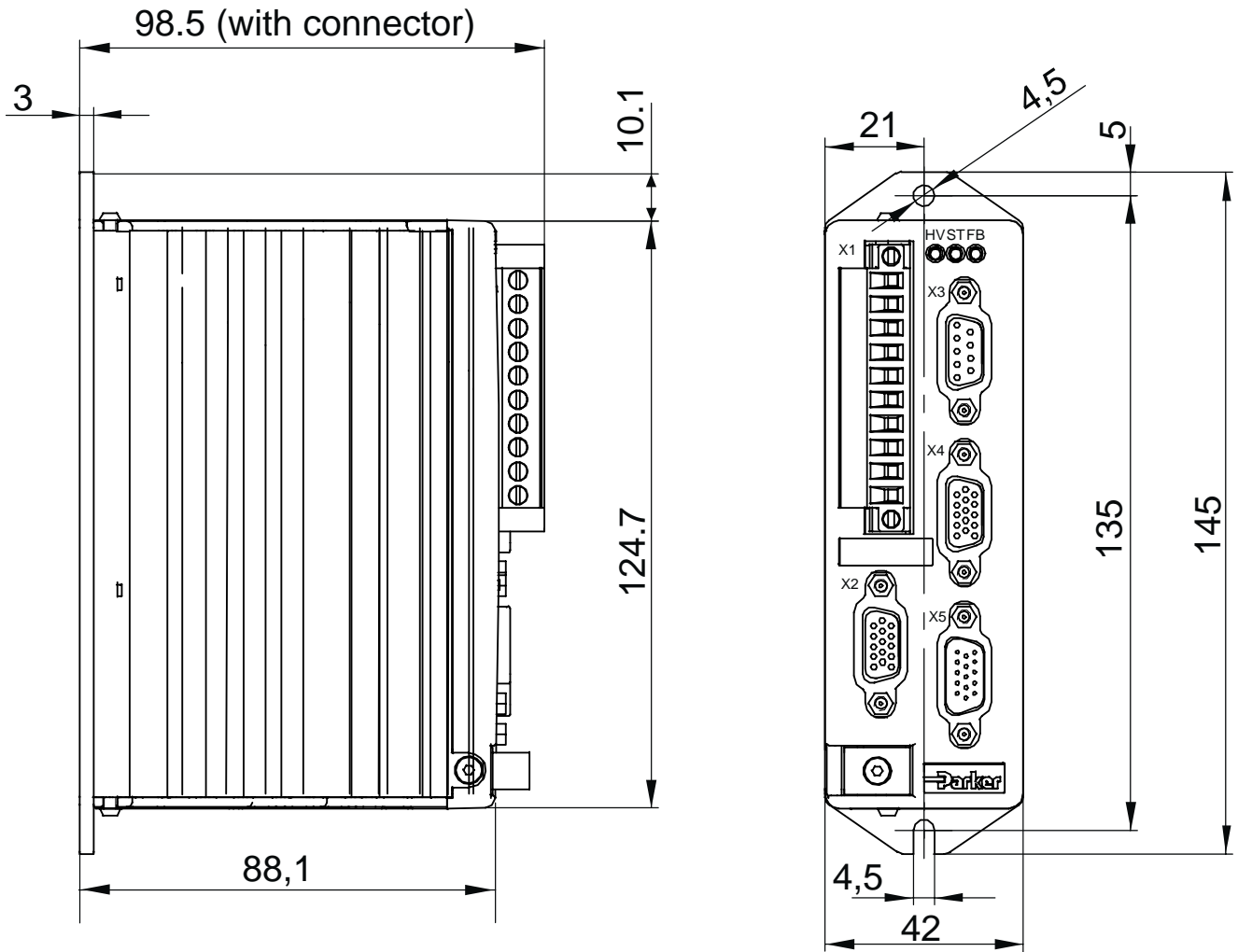
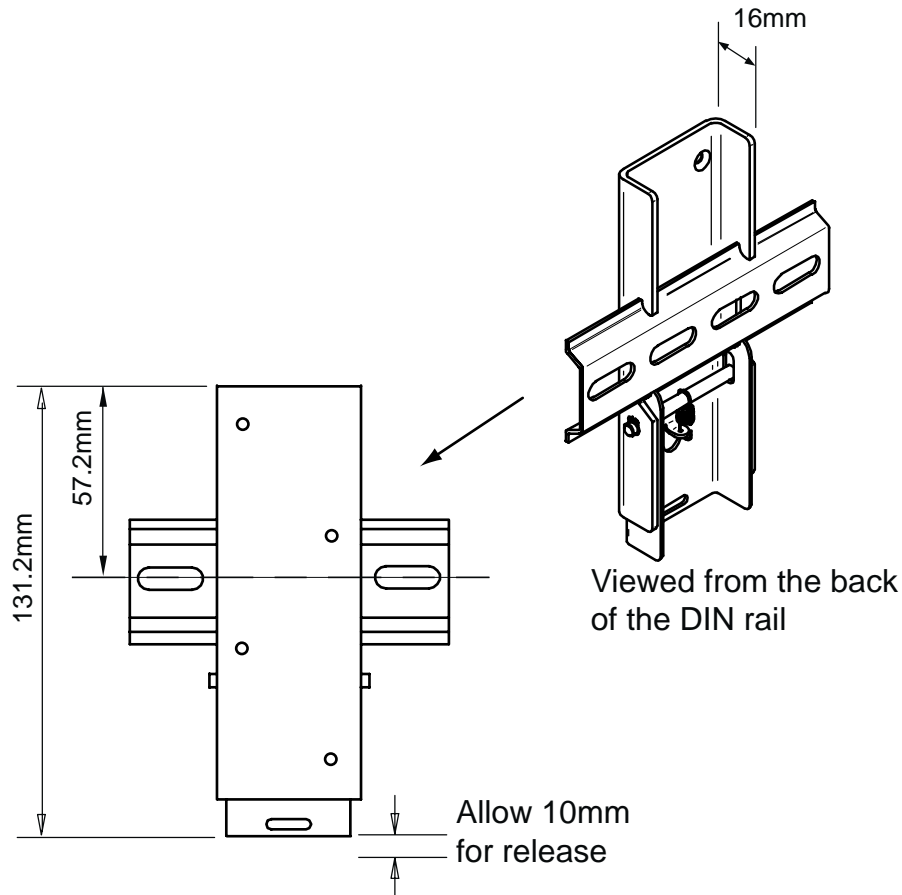

Figure 2-1. ViX250 & ViX500 Dimensions

## Drive Mounting Options

If you require a DIN-Rail mounting ViX drive use the **DIN-Rail clip** adapter bracket shown in Figure 2-2.



**Figure 2-2. DIN-Rail Adapter Bracket**

Remove the panel mounting plate from the back of the drive and attach the bracket to the back of the drive using the screws provided. The drive and bracket can now be fixed to a DIN rail by hooking the top of the bracket over the top of the DIN rail and gently pushing the drive forward to engage the lower section of the bracket. Remove the bracket by inserting a flat bladed screwdriver into the release slot to pull down the bottom of the bracket, releasing it from the DIN rail.

## Thermal Limitations

If you are using DIN rail mounting with natural convection airflow cooling and the drive is working under continuous load, the maximum continuous output torque should be de-rated by 10%. For example, using the drive for reel tensioning rather than point-to-point applications may require torque de-rating when using DIN rail mounting.

### **Motor Mounting Mechanical Considerations**

Keep motors securely fixed in position at all times. Do not test a motor/drive combination without first securing the motor – see the Safety Warning at the front of this user guide.

**CAUTION – risk of equipment damage**

**Do not back drive the motor, that is use the motor in an application that causes mechanical rotation of the motor shaft in a manner uncontrolled by the drive.**

**Back driving the motor at high speed may damage the drive.**

---

## 3. Electrical Installation

---

### Installation Safety Requirements

ViX drives meet the requirements of both the European LVD & EMC directives when installed according to the instructions given within this section. It is recommended the drive be installed in an enclosure to protect it from atmospheric contaminants and to prevent operator access while it has power applied. Metal equipment cabinets are ideally suited for housing the equipment since they can provide operator protection, EMC screening, and can be fitted with interlocks arranged to remove all hazardous motor and drive power when the cabinet door is opened. Do not arrange interlocks to open circuit the motor phase connections while the system is still powered, as this could cause damage to the drive.

### Precautions

During installation, take the normal precautions against damage caused by electrostatic discharges. Wear earth wrist straps. A switch or circuit breaker must be included in the installation, which must be clearly marked as the disconnecting device and should be within easy reach of the machine operator.

### Cabinet Installation

To produce an EMC and LVD compliant installation we recommend that drives are mounted within a steel equipment cabinet. This form of enclosure is not essential to achieving EMC compliance, but does offer the benefits of operator protection and reduces the contamination of the equipment from industrial processes.

A steel equipment cabinet will screen radiated emissions provided all panels are bonded to a central earth point. Separate earth circuits are commonly used within equipment cabinets to minimise the interaction between independent circuits. A circuit switching large currents and sharing a common earth return with another low level signal circuit could conduct electrical noise into the low level circuit, thereby possibly interfering with its operation. For this reason so called 'dirty earth' and 'clean earth' circuits may be formed within the same cabinet, but all such circuits will eventually need to be returned to the cabinet's main star earth point.

Mount the individual drives and EMC filter on a metal earth plane. The earth plane will have its own individual star point earth which should be hard wired (using an insulated copper conductor) back to the cabinet's 'clean earth' connection point.

LVD - Low voltage directive

EMC – Electro Magnetic Compatibility directive

## Power Supply Connections

Power drives from a DC supply derived from an isolating transformer or a DC power supply (See **Power Supply Options** later in this section).

**Note:** Pin 10 is at the top of the connector X1 and pin 1 at the bottom.

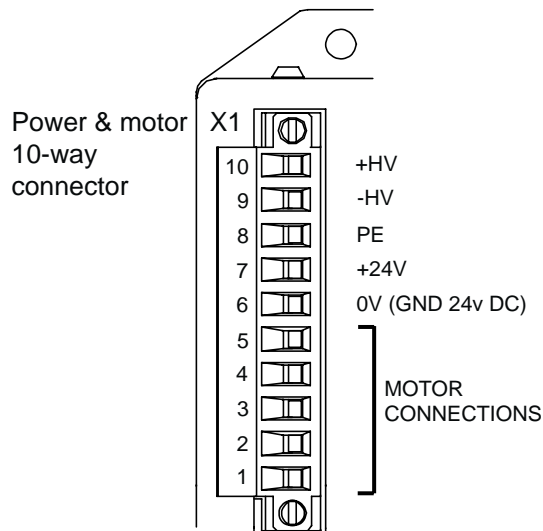

Figure 3-1. X1 Power Connections

### WARNING – Possible drive damage

**If you use Parker XL Series stepper drives do not attempt to use any power wiring harness taken from an XL drive. Although the same mating connector is used for both an XL and a ViX, the ViX wiring is the reverse of the XL and the wrong wiring connection will damage the drive.**

Mating connector type is: Wieland type number 8213B/ . This connector is available in two forms:

1. Part number 25.323.4053.0 (Parker part number 0405.811)
2. UL marked version with part number 25.323.1053.0



## Supply Requirements

Power the ViX drives from DC supplies as specified below:

### Volts

Drive Type	DC Supply Voltage between DC+ and DC-
ViX500	48V to 80V (recommended)
ViX250	24V to 80V

**Table 3-1. Drive Supply Voltages**

### WARNING

**The drive HV supply input is not reverse polarity protected.  
Reverse polarity connections will damage the drive.**

## Current and Capacitance

A supply must have a minimum amount of capacitance to support a drive at peak power draw.

Drive Type	DC Supply Current	Supply Capacitance
ViX500	6.3A RMS	6600 $\mu$ F
ViX250	2.5A RMS	3300 $\mu$ F

**Table 3-2. Drive Supply Currents**

## +24V Requirements

Both drive types require a +24V controller and logic supply. The supply to each drive should be fitted with a time-delay fuse, rated at 3A. Note: The +24V supply used must meet the voltage requirement specification of +24V DC +10% -15%, ripple <1V p-p.

The supply may also be required for an encoder and motor brake.

Absolute voltage range	20 to 27V
Nominal drive current	250mA (excluding encoder & brake)
Extra encoder current	150mA
Extra brake current	500mA

## Safety Earth Requirements

Earth the drive using the earth pin on X1 (pin 8). Also earth the power 0V connector on pin 9.

## Power Supply Options

Using the previous section, estimate the power required for a single drive or for a group of drives. A set of torque curves (Figure 3-2) for various motor/drive combinations can be used for calculating an applications likely power requirements.

A single axis using a ViX250, or possibly a lightly loaded dual-axis application may be powered using an XL-PSU. This switching supply has a power rating of 250W and can supply 3.1A continuous (7.5A peak, depending on supply volts and 24V loading) which could be used for BE230D medium speed applications.

Higher torque/current requirements will need to use the ViX500 drive and a high current linear supply, such as the PL1100. Further power supply information is given in **Appendix A.**

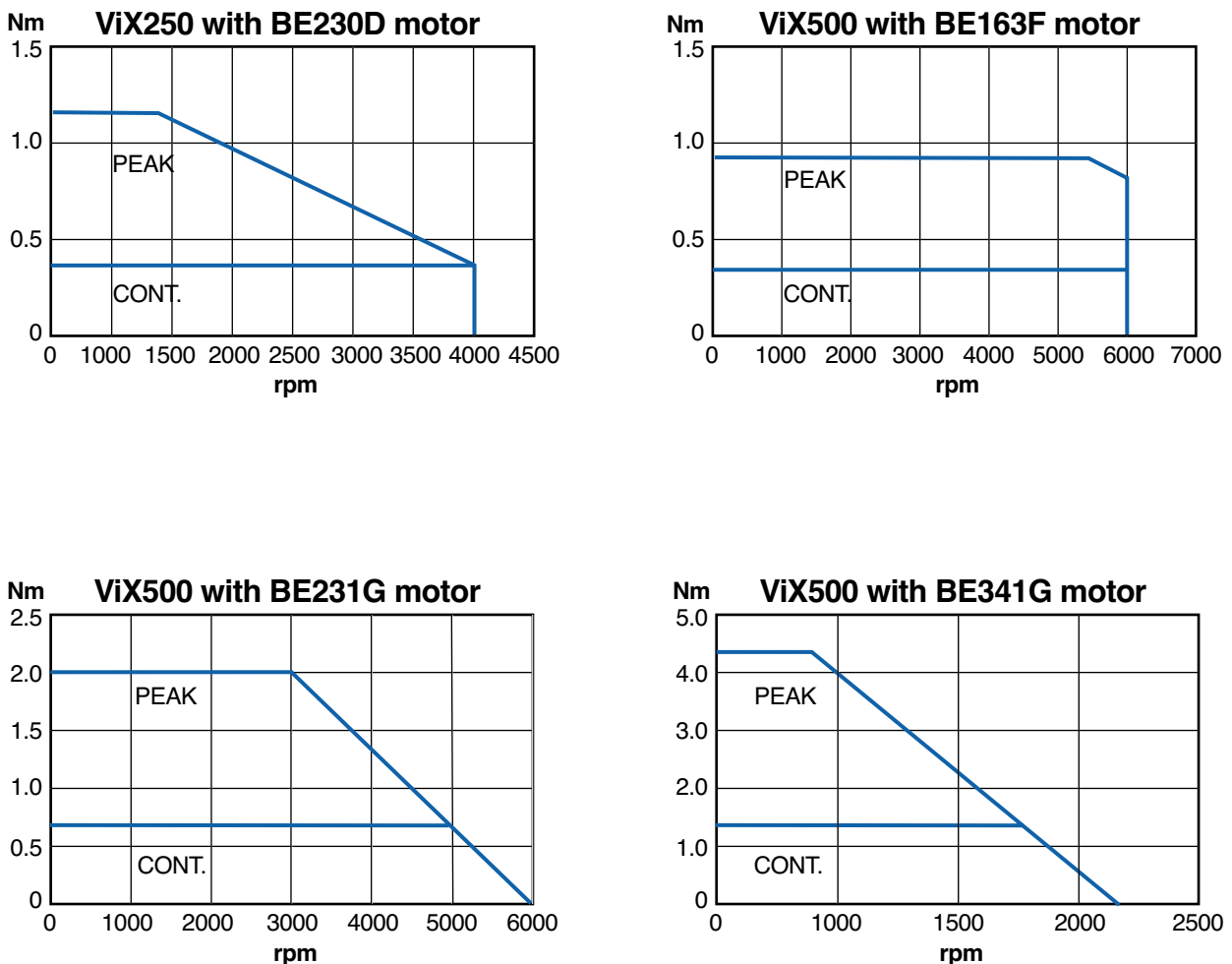

Figure 3-2. Motor Torque/Speed Characteristics

## **XL-PSU Power Supply**

---

The XL-PSU is a 250W, power factor corrected, switched mode power supply. Designed for direct operation from world wide single phase AC input voltages, the supply is capable of powering up to two ViX250 drives without the need for an EMC mains input filter. The use of the XL-PSU offers the following benefits:

- Auto-adapts to supplies between 95 and 264V AC
- No external EMC filter required
- Compact size
- Built-in power dump switch
- Built-in +24V DC supply

Note 1: Check the application's power requirements from the torque/speed curve of the motor used.

Note 2: For drives with up to 30 metre motor leads.

**For full installation instructions see the XL Power Supply leaflet 1600.300.XX.**

### XL-PSU Supply/Drive Connections

When used to supply up to two drives the power supply can be wired as shown in Figure 3-3.

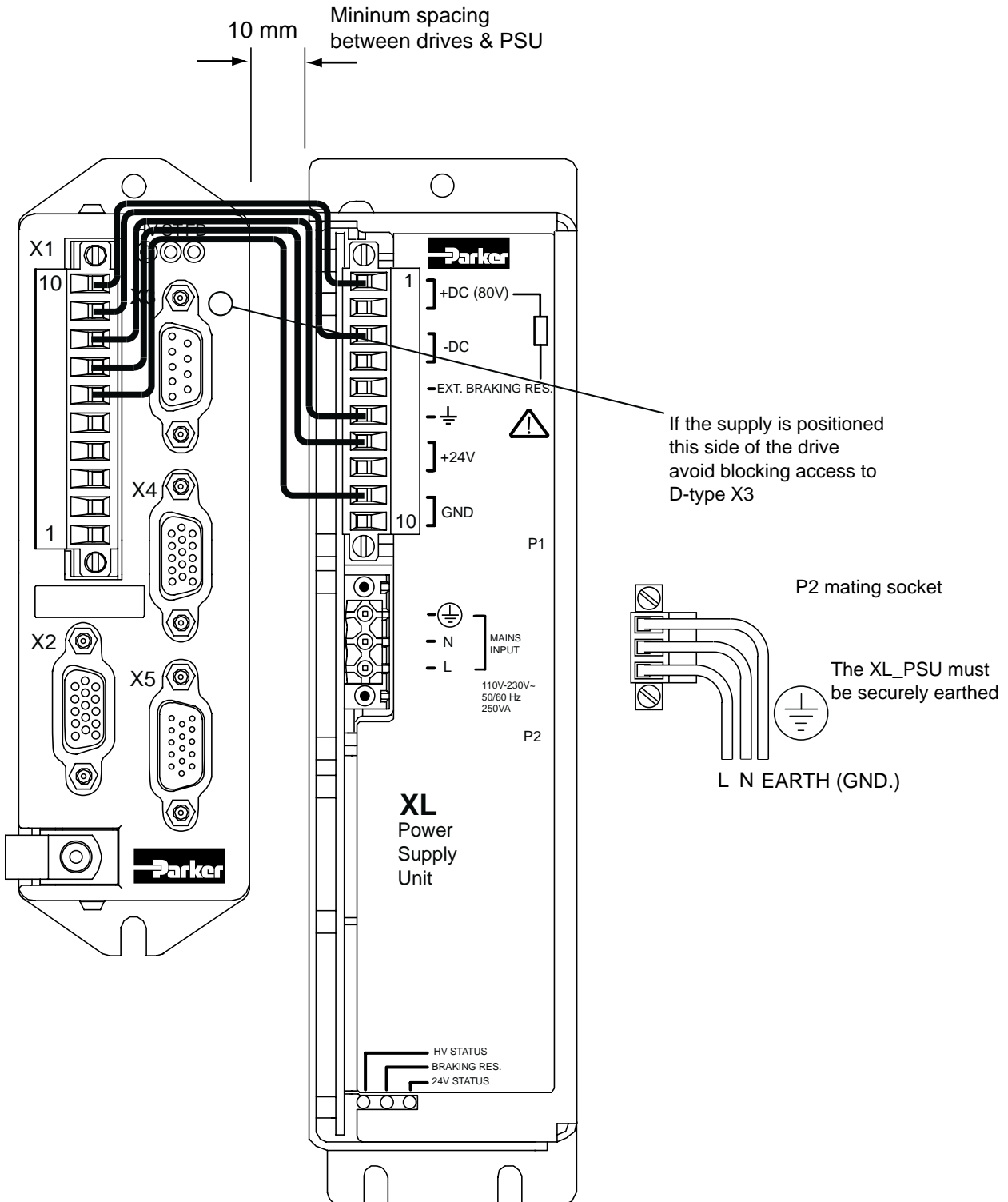

Figure 3-3. XL Power Supply and Drive Connections

***XL-PSU Mounting Information***

Mount the supply vertically, near the drives it will supply. Both the top 4.5mm diameter fixing hole and the bottom two 4.5mm width fixing slots should be used.

Allow a minimum free space of 50mm both below and above its case and 10mm free space on both sides.

Do not mount the supply above or close to other products that generate a significant amount of heat by radiation or convection.

---

## PL1100 Power Supply

### General Description

The PL1100 is a linear power supply with a rated output of 1120W (80V/14A) for use with ViX and XL series drives. The supply requires a suitably rated transformer supplying 50V AC RMS for the HV and 20V AC RMS for the +24V DC. The use of the PL1100 offers the following benefits:

- Provides 80V HV and +24V DC output
- Single or three phase operation
- Built-in power dump switch
- Integral fusing

Figure 3-4 shows the PL1100 output wiring for two ViX drives. This illustrates how to route the main HV supply separately to each drive. The lower current requirements of the +24V logic/brake supply can allow the wiring to be linked between drives.

**For full installation instructions see the PL1100 Power Supply leaflet 1600.323.XX.**

In Figure 3-4 the drives are wired individually to the PL1100, alternative daisy chain wiring can be used.

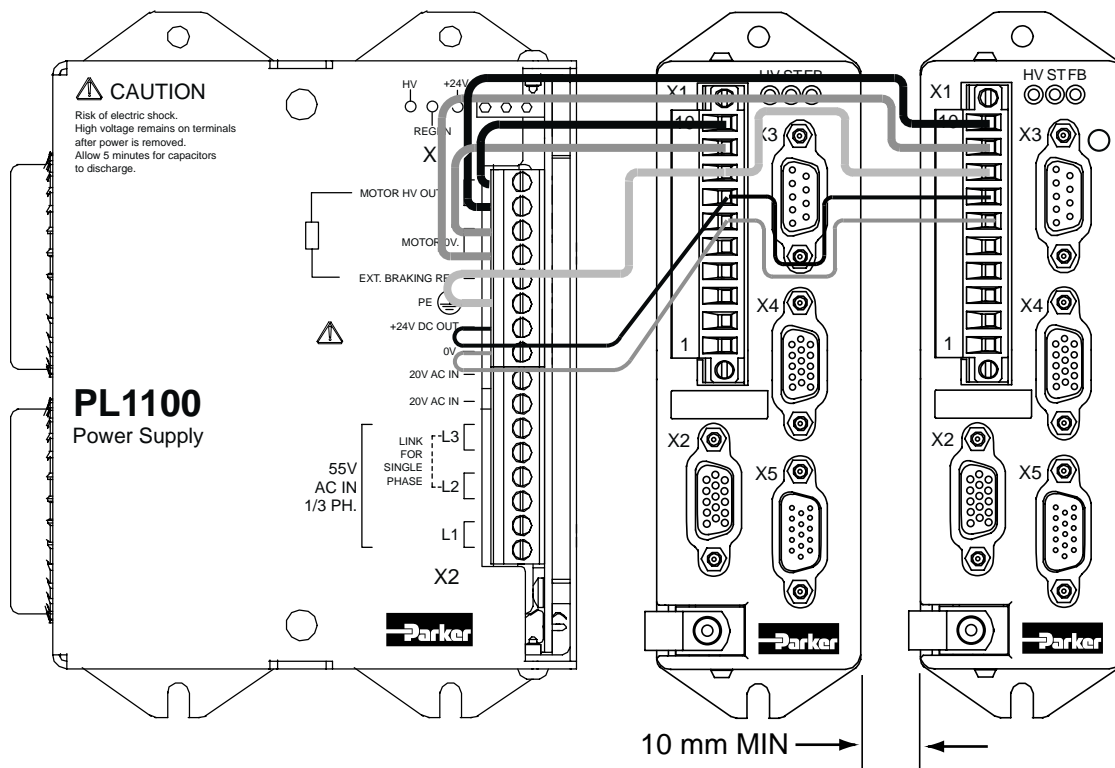

Figure 3-4. PL1100 Power Supply and Drive Connections

## PL1100 EMC Installation Guidelines

These EMC installation recommendations are based on the expertise acquired during the development of compliant applications, which Parker believes are typical of the way, a PL1100 may be used. Provided you have no special installation requirements or untypical operating environment requirements, PL1100 power supplies will conform to current EMC Directives.

If you are using the recommended transformers (TO255 & TO256) both primaries can be fed from a single EMC filter. Use a CORCOM 12FC10 or its equivalent. See Figure 3-5.

Mount the supply on a conductive panel to which the EMC filter and the drive(s) are also attached. If the panel has a paint finish, it will be necessary to remove the paint in certain areas to ensure the filter and supply, make a good large-area metal to metal contact with the panel.

Position the PL1100 as close as possible to the drives it is to supply (less than one metre). Ideally, the EMC filter needs to be close to the transformers, which in turn, should be as close to the PL1100 as can be arranged. Assuming the use of an equipment cabinet, locate the EMC filter and transformers in the base of the cabinet and route AC supply cables up to the PL1100. Attempt to layout the wiring in a way that minimises cross coupling between filtered and non-filtered conductors. This means avoiding running wires from the output of a filter close to those connected to its input. Where you wish to minimise the cross coupling between wires avoid running them side-by-side one another, if they must cross, cross them at 90° to each other. Keep wiring supported and close to cabinet metalwork.

## HV Transformer Specification (TO255)

Power rating	1000VA
Input voltage	230V +15% -10%
Output voltage	2 X 50V RMS full load voltage
Output current	2 X 10A RMS
Regulation	3.5%
Size	162mm diameter, 70mm height
Weight	6.5Kg
Mounting	resin filled centre, drilled to accept an 8mm mounting screw.

See note 1, over the page.

## Suitable Transformer (TO256)

A +24V DC logic supply can use the TO256 120VA toroidal transformer, which has the following specification:

Power rating	120VA
Input voltage	230V +15% -10%
Output voltage	2 X 18V RMS full load voltage
Output current	2 X 3.3A RMS
Regulation	5.5%
Size	93mm diameter, 46mm height
Weight	1.2Kg

Mounting resin filled centre, drilled to accept an 8mm mounting screw.  
 See note 1, over the page.

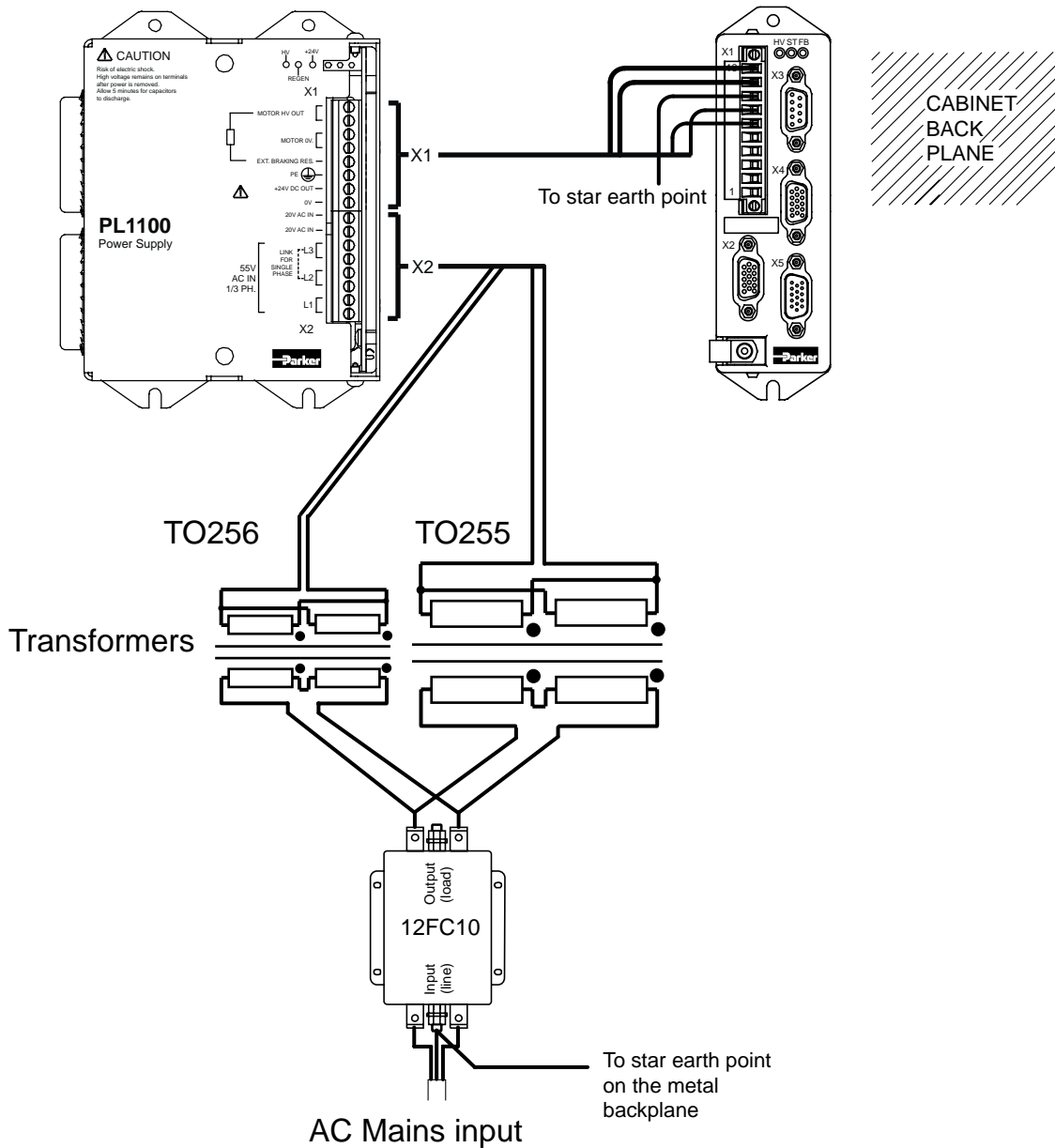

**Figure 3-5. Using a single EMC Filter for PL1100 Supplies**

Note 1: A Neoprene insulating disc is included with the mounting kit to prevent the crushing of transformer windings. This disc provides a 5kV isolation barrier between the transformer and mounting panel.



### SMB Motor Cables

The following motor power and feedback cables are available for ViX drives:

Power cable	Feedback cable
VIX-PWR-XXXX	VIX-FDB-XXXX

**Table 3-3. Motor Power and Feedback Cables**

Where XXXX is the length of the cable in cm, up to a maximum length of 20 metres in 2.5 metre increments. In the case of SMB motor cables the feedback cable can be used for resolver or encoder feedback. **Not required for use with the ViX250/500AH drives.**

### BE & SM Motor Cables

When using BE- or SM-Series motors choose the appropriate connector option to ensure the temperature sensor output is made available on the required connector:

- BE- nMSn
- SM- nGSn

Motor power cables are identified using the number **71-021125-XX**, where **XX** is the length of the cable in feet, up to a maximum of 50ft (15.24m) in 5ft (1.524m) increments.

The form of feedback cable used with both the BE- and SM- range will depend upon the type of feedback transducer:

- Encoder feedback **71-021124-XX**

Once again **XX** defines the length in feet.

Should you require a BE or SM servo motor with a mechanical brake, please contact Parker-EMD. See the front of this user guide for contact details.

### Motor Connections at the Drive

Standard motor power cables are prepared for connection at the drive end as shown in Figure 3-6.

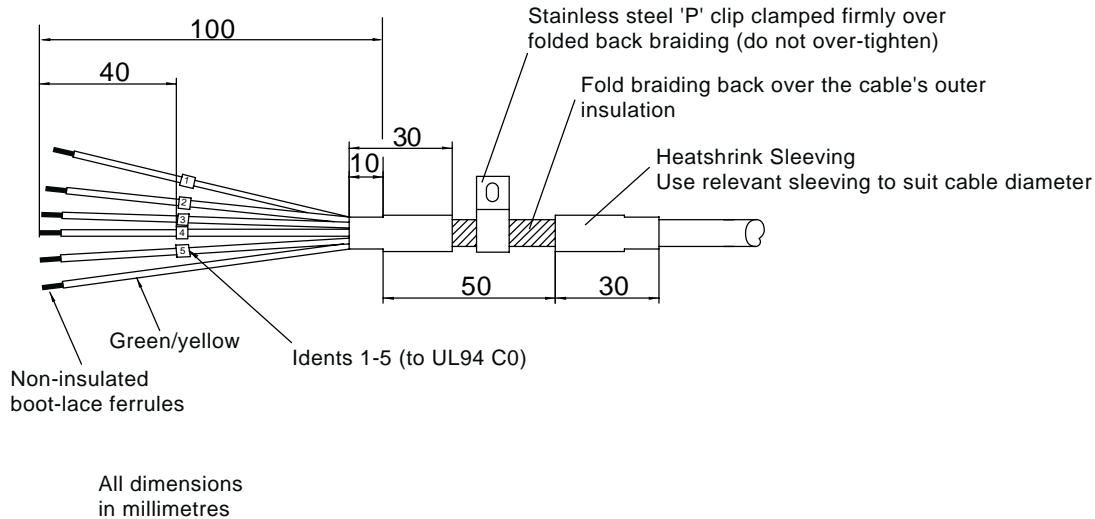

**Figure 3-6. Motor Power Cable, Drive End Preparation**

Note: The cable braiding is folded back over the outer insulation of the motor cable to give a larger diameter contact area and a mechanically strong fixing.

The following P-clips sizes are available:

Size	Parker part number	Comments
12.3mm ID	4216.103	Supplied with standard cables
10.7mm ID	4216.102	-
9mm ID	4216.101	-
4.2mm	4216.106	-
3.7mm	4216.105	-

**Table 3-4. P Clip sizes**

Different size 'P' clips allow the use of a variety of motor power cables from different manufactures.

All motor connections must be made using a high quality braided-screen cable. Cables using a metallised plastic bandage for an earth screen are unsuitable and in fact provide very little screening. Care must be taken when terminating the cable screen, the screen itself is comparatively fragile; bending it round a tight radius can seriously affect the screening performance. The selected cable must have a temperature rating which is adequate for the expected operating temperature of the motor case.

15-way D-type pin reference X2	Encoder
1	Inc Enc Z+
2	Inc Enc Z-
3 (twin)	0V
4	Reserved
5 (twin)	+5V output
6	0V
6	Motor overtemp-
7	Inc Enc A-
8	Inc Enc A+
9	Comm f-b A0
10	Motor Overtemp+
11	Inc Enc B-
12	Inc Enc B+
13	Comm f-b A1
14	Comm f-b A2
15	Reserved

Note: two wires are used for the +5V supply (X2 pin 5) and two wires are used for 0V returns (X2 pin 3), two wires are also taken from X2 pin 6.

**Table 3-5. Motor Feedback Cable Wiring**

The 15-way D-type connector will require the feedback cable screen to be bonded to the metal connector shell, as shown in Figure 3-7.

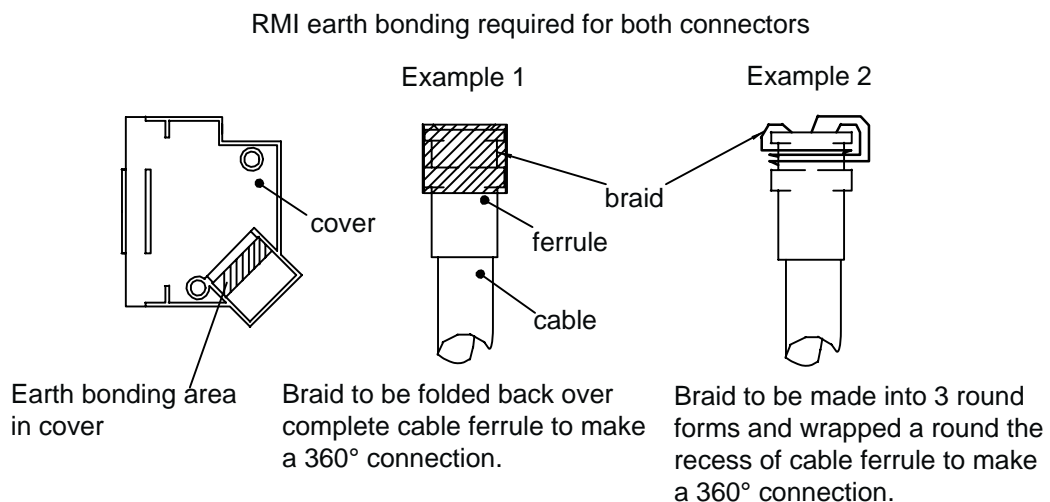

**Figure 3-7. Screen Bonding Methods for D-type Connectors**

A ferrite absorber, with a specification matching that of the Chomerics H8FE-1115-NC, is also required to be positioned on the feedback cable using heat shrink sleeving. The position of the absorber should be within 150mm of the feedback connector, as shown in Figure 3-8.

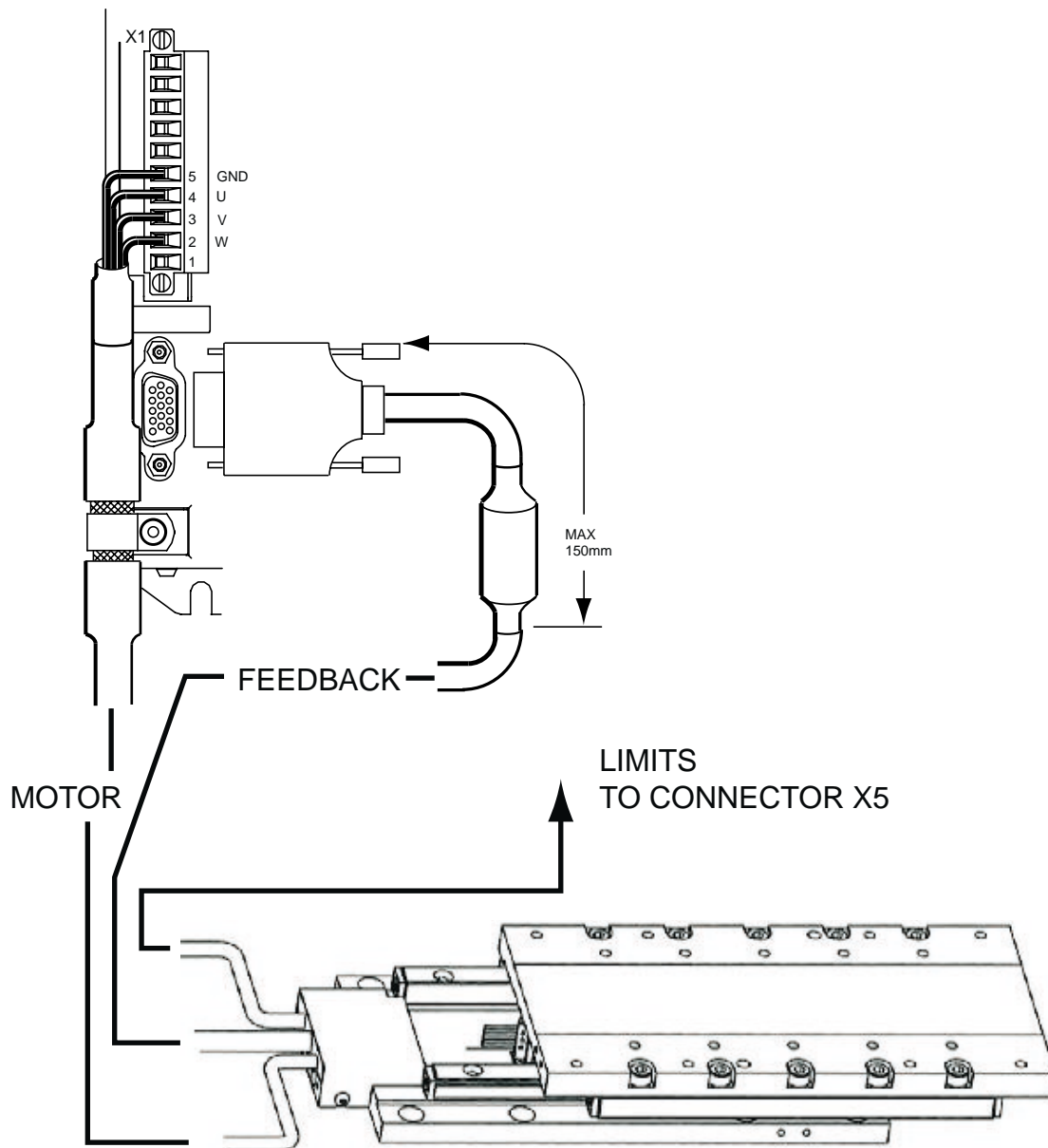

**Figure 3-8. Position of absorbers & motor wiring details**

There must be no break in the 360° coverage that the screen provides around the cable conductors.

Use of a through connector must retain the 360° coverage, possibly by the use of an additional metallic casing where it passes through the bulkhead of the enclosure. We recommend not to bond the cable screen to the cabinet at the point of entry. Its function is to return high-frequency chopping current back to the drive. This may require mounting the connector on a sub-panel insulated from the main cabinet, or using a connector having an insulated internal screen from the connector housing. Within the cabinet itself, all the motor cables should lie in the same trunking as far as possible. Keep the cables separate from any low-level control signal cables. This applies particularly where the control cables are unshielded and run close to the drive.

Note: keep the motor cable routing within the equipment cabinet at least 300mm away from I/O cables carrying control signals.

#### **Motor Phase Contactors**

We recommend that motor phase contactors are not used within the motor power cables. As an alternative, make use of the drive's power stage 'enable' control signal.

#### **Ferrite absorber specifications**

The absorbers described in these installation instructions use a low-grade ferrite material that has high losses at radio frequencies. They therefore act like a high impedance in this waveband. Produced by Parker Chomerics, the recommended component is suitable for use with cable having an outside diameter up to 10mm. The specification is as follows:

Chomerics part number H8FE-1115-NC (Parker part number 0313.020)

Outside diameter 17.5mm

Inside diameter 10.7mm

Length 28.5mm

Impedance at 25MHz 80 ohm

Impedance at 100MHz 120ohm

Curie temperature 130°C (the device should not be operated near this temperature)

---

## Motor Selection and Set Up

Generally, a servo motor is selected together with a drive based on the required speed/torque performance suitable for the intended application. The ViX product catalogue carries details of the performance of the drive when used with a range of recommended servo motor types.

Performance of the ViX is optimised for the following motor types, listed in Table 3-6.

Motor Type	Motor Rated Current in Amps	Motor Inductance in mH per phase	ViX500	ViX250
BE231GX-XXXX	5.3	4.4	✓	✓
BE341GX-XXXX	5.2	16.5	✓	
BE341JX-XXXX	7.4	7.1	✓	

**Table 3-6. Optimum Motor Types**

Configuration information is available for each of the above motor types in the **Guided servo initialisation** part of EASI-V. If you wish to use a motor other than the types listed above, you will need to perform a custom set up. EASI-V allows the use of 55 custom motor types.

### Custom Motor Set Up

Within screen 2 of **Guided servo initialisation**, clicking upon the Setup custom button will open the window shown in Figure 3-9.

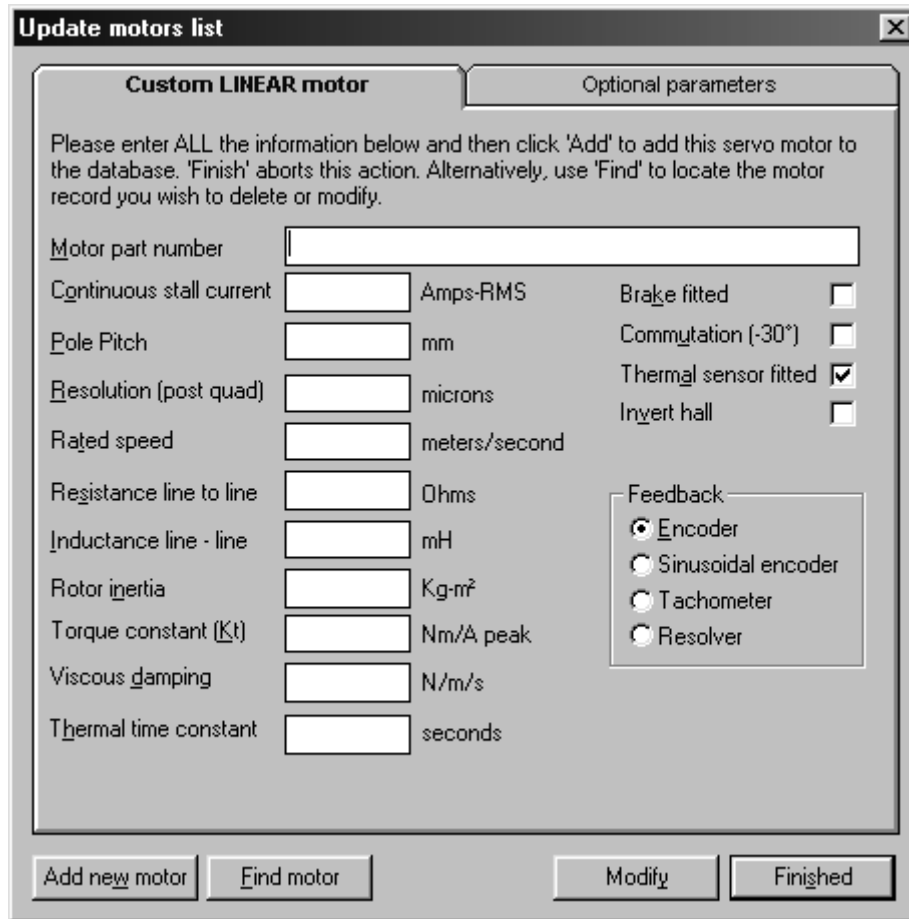
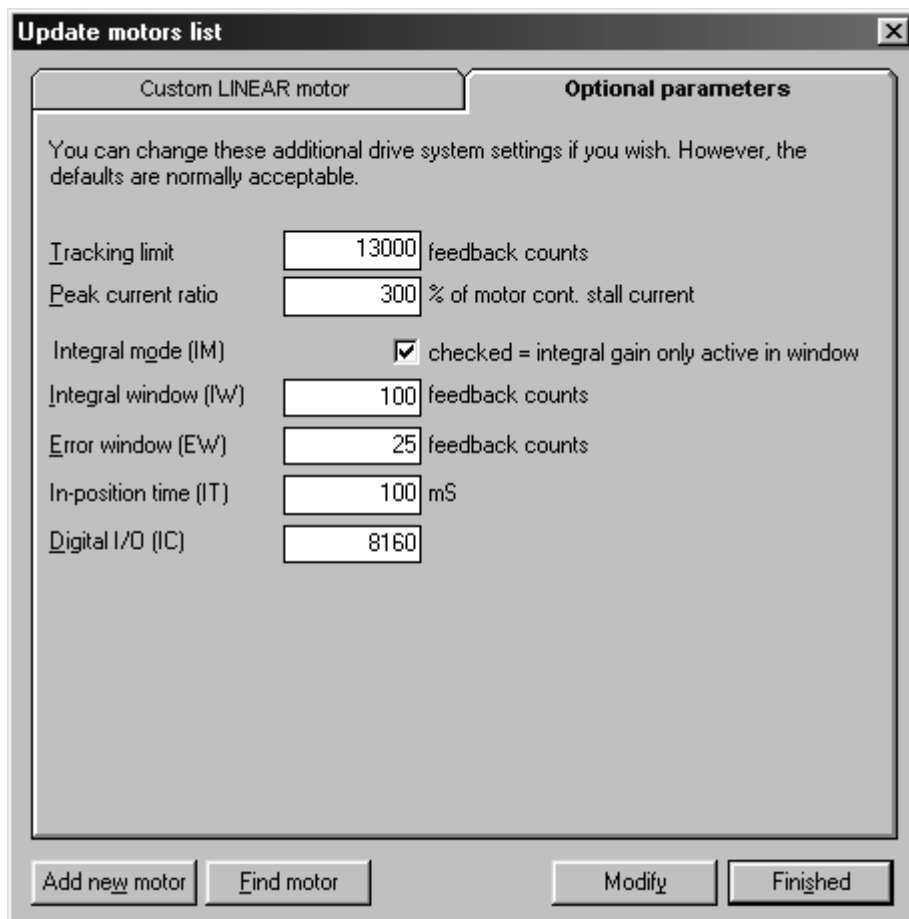

**Figure 3-9. EASI-V Custom Motor Configuration Window**

Motor	the general name/number for the motor.
Nominal current	continuous current rating of the motor in Amps RMS. (0.1 to 14.4)
Number of poles	number of motor poles for a rotary servo (2 pole/pairs = 4 motor poles, so enter 4).
Resolution <b>Note:</b>	post quadrature resolution of a rotary servo. For a resolver use 4096. post quadrature is the number of encoder lines 'seen' by the drive electronics after the encoder signal has been processed.
Rated speed	shaft speed in rpm for a rotary servo.
Resistance	resistance of a single phase winding measured line-to-line in Ohms.
Inductance	inductance of a single phase winding measured line-to-line in mH.
Inertia	inertia of a rotary servo stator measured in Kg <sup>m</sup> ².
Kt	torque constant of the motor (Torque/Current) measured in Nm/A peak.
Damping	viscous damping of the motor caused by such things as iron losses, measured in Nm/Krpm.
Thermal time constant	a constant that determines how slowly or quickly the motor temperature rises to its final steady-state value measured in seconds.

### The Optional Parameters Tab

Selecting the optional parameters tab gives you access to the screen shown in Figure 3-10.



**Update motors list** [X]

Custom LINEAR motor      **Optional parameters**

You can change these additional drive system settings if you wish. However, the defaults are normally acceptable.

Tracking limit	<input type="text" value="13000"/>	feedback counts
Peak current ratio	<input type="text" value="300"/>	% of motor cont. stall current
Integral mode (IM)	<input checked="" type="checkbox"/>	checked = integral gain only active in window
Integral window (IW)	<input type="text" value="100"/>	feedback counts
Error window (EW)	<input type="text" value="25"/>	feedback counts
In-position time (IT)	<input type="text" value="100"/>	mS
Digital I/O (IC)	<input type="text" value="8160"/>	

**Figure 3-10. EASI-V Custom Motor Optional Parameters**



## Motor Related System Variables

Two-system variables control the current supplied to the motor from the drive. Current Clamp (CL) limits the current output of the drive to protect low current motors or to set a particular torque level, and Peak Current (PC) can allow a controlled boost of motor current when required.

CL can be set as a percentage (1 to 100%) of the peak drive current and once set drive output current cannot be exceeded using any other command or system variable.

PC sets the scale factor (100 to 400%) that controls the ratio of maximum output current to continuous output current of the drive. Servo motors can be overdriven for short periods to provide extra torque. PC is calculated as follows:

$$PC = \frac{\text{desired maximum drive current}}{\text{motor continuous stall current}} \times 100$$

A value of 300% is typically used for boosting servo motor performance.

Enter CL and PC values using EASI-V guided servo initialisation or directly, using the **W** command.

## Drive/Motor Overload

The ViX drive uses an I<sup>2</sup>t protection scheme that prevents excessive heat dissipation in the drive and motor. Protection operates by monitoring the level of three separate dissipation parameters and comparing them to their individual I<sup>2</sup>t thresholds. These dissipation parameters are:

- Motor I<sup>2</sup>T – protects the motor from drive output current above the rated motor current that is applied for too long a time.
- Moving I<sup>2</sup>T – protects the drive from output current while moving, that is above the rated drive current for too long a time.
- Stationary I<sup>2</sup>T – protects the drive from output current while stationary, that is above the rated drive current for too long a time.

If any one of these monitored parameters exceeds the set I<sup>2</sup>t threshold, the drive current folds back to 80% of the normal running continuous limit. The status LED will continuously flash red and green and status bit 16 of the system variable ST will be set to '1'. The drive output will remain at the 80% level for 30 seconds, after which the parameter that caused the I<sup>2</sup>t threshold to be exceeded is re-tested. If the re-tested parameter has dropped in value by 50% or greater of its original fault level, the drive output is returned to its normal current level. If the failing parameter is found to be still high (>50%) the drive output remains restricted to its 80% value and continuous checking of the parameter is carried out until the 50% value is reached. When this happens, the drive returns to normal operation, the status LED stops flashing and ST bit 16 is reset.

## **Control of I<sup>2</sup>t Parameters**

The drive internal I<sup>2</sup>t parameters are always enabled and cannot be adjusted by the user. However, the motor I<sup>2</sup>t settings can be influenced by the choice of parameters used for the MOTOR command. To disable the motor I<sup>2</sup>t settings, set the thermal time constant of the motor to zero.

Note: If you select a motor from the list of 'standard motors' using EASI-V, worst case configuration data will be used. This prevents reporting a too optimistic view of the motors thermal performance.

Where a motor is fitted with a temperature sensor built into its windings the motor I<sup>2</sup>t threshold protection will not be required. In this case, set the thermal time constant of the motor to zero (see **MOTOR** command).

### ***Motor Voltage Ratings***

Motors with a withstand voltage rating from phase to earth of 1000V AC should be used. An insulation withstand rating of 500V AC is acceptable if an isolating transformer with earthed screen is used to power the system, and X1 pin9 (0V/GND) input is earthed, as specified.

## **Motor Safety Earth/Ground Connection**

It is recommended that the motor is independently bonded to a local safety earth point. The safety earth lead should be at least 2.5mm<sup>2</sup> in area.

## **Short Circuit Protection**

The motor outputs are protected against overload and short circuits. Overload is protected by the I<sup>2</sup>t circuit, and 300% of continuous drive current rating is only permitted for 2 seconds. A current level just above rated current is only permitted for a maximum of 20 seconds.

### Plots of $I^2t$ Against Drive Current

The following graphs plot drive current against  $I^2t$  time in seconds for a moving and stationary motor for both power versions of the drive.

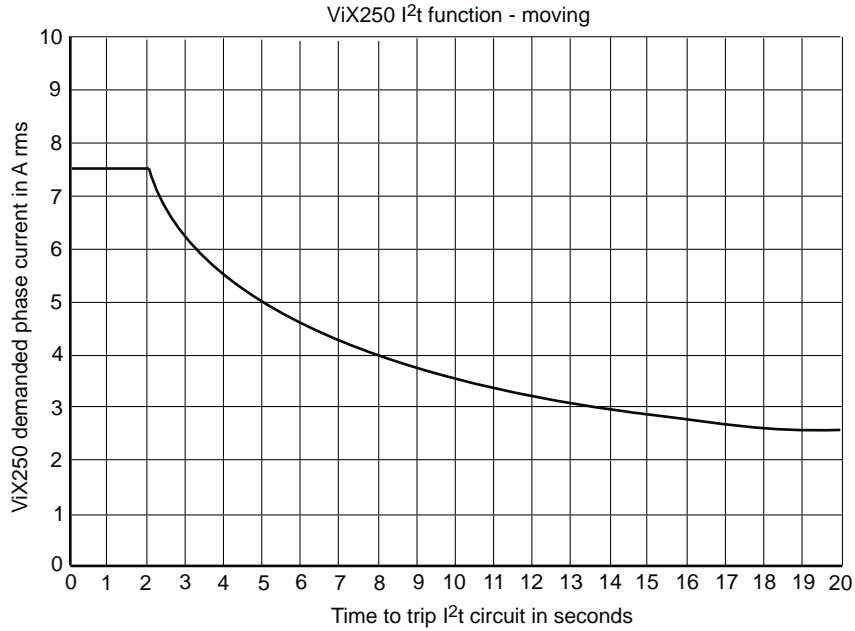

**Figure 3-11. ViX250  $I^2t$  function - moving**

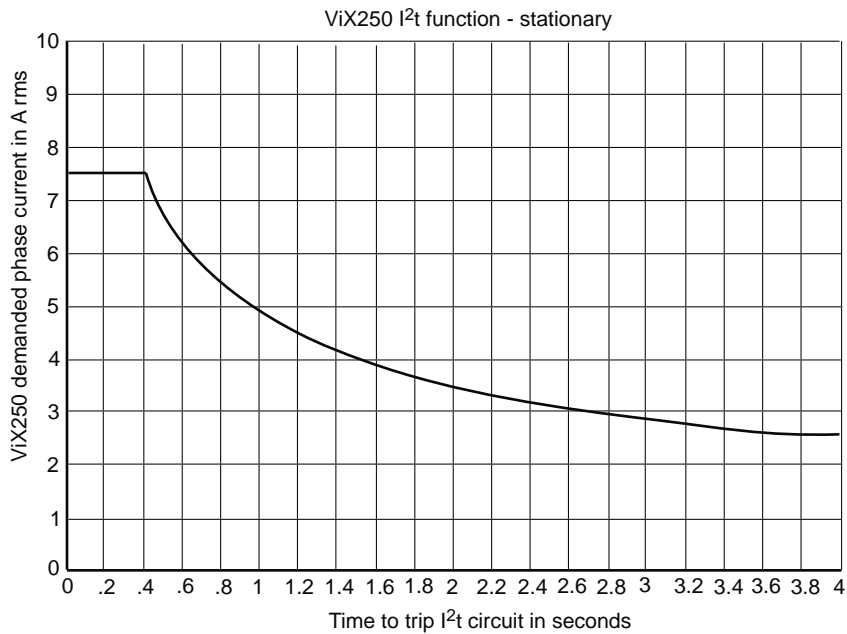

**Figure 3-12. ViX250  $I^2t$  function - stationary**

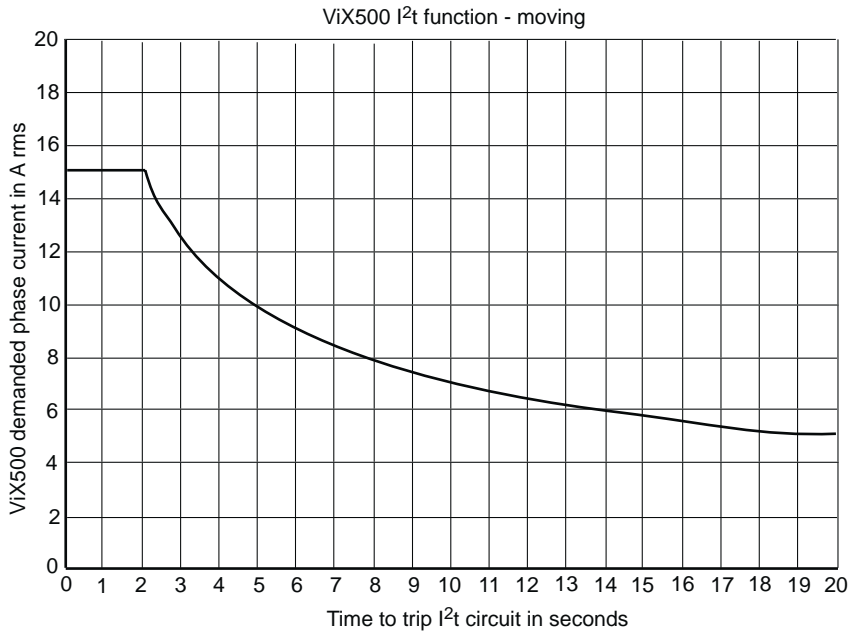

**Figure 3-13. ViX500 I<sup>2</sup>t function - moving**

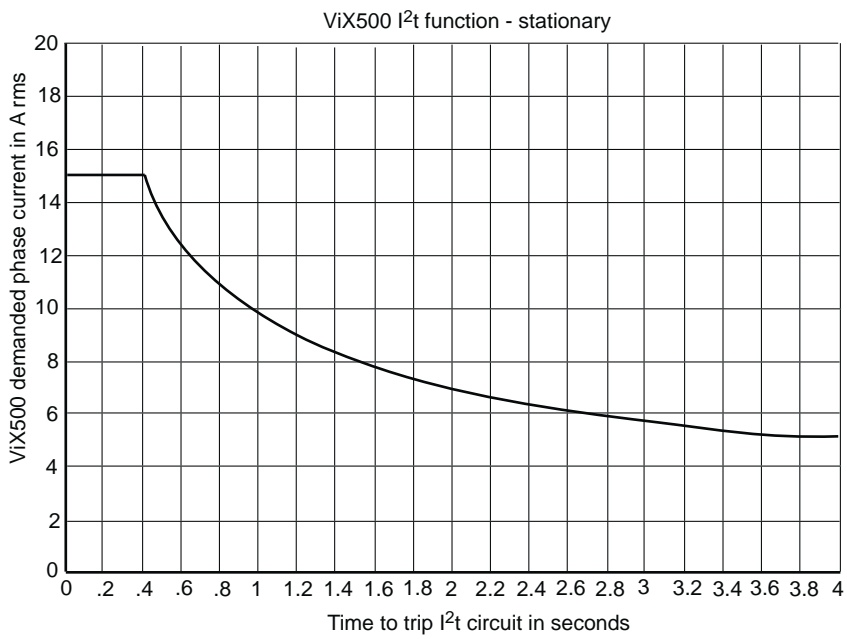

**Figure 3-14. ViX500 I<sup>2</sup>t function - stationary**

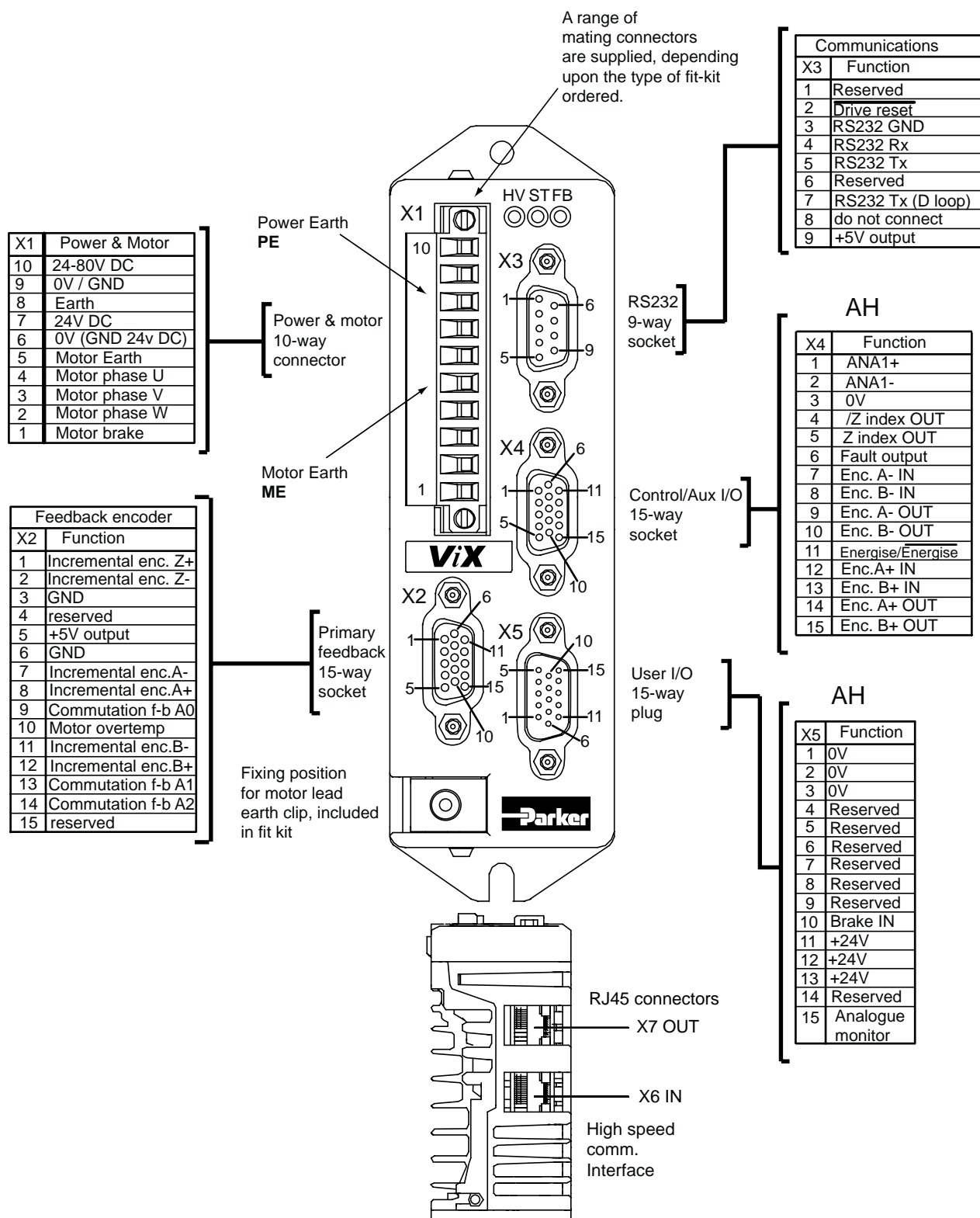

Figure 3-15. ViX Connector Pin Layout

## Terminal Description

### X1 Connector

X1 is the main power and motor connector. Both HV, +24V and the motor phase connections are made to X1. A brake connection is also provided via X1 pin1.

#### **Connector Type**

The mating connector for X1 is a Wieland type 213B/, part number 25.323.4053.0 (Parker part number 0405.811). An approval marked version of this connector has the part number 25.323.1053.0.

#### **Connector Pin Out**

Connector Pin X1	Signal Name
10	24 to 80V DC
9	0V/GND
8	Earth
7	24V DC
6	0V (GND for 24V DC)
5	Motor Earth
4	Motor phase U
3	Motor phase V
2	Motor phase W
1	Motor brake

**Table 3-7. X1 Power and Motor Connections**

#### **Motor Connections at the Drive**

Refer to the EMC installation information earlier in this section.

#### **Motor Brake Output**

The motor brake output on pin 1 is available as a direct control of a 24V motor brake and is capable of sinking a current (up to 4A RMS) to 0V to keep the brake disengaged. A 2A fuse is required to protect against a wiring fault, since no over current protection is provided by X1 pin 1.

Motor brakes are fail safe that is removal of the brake current will apply the brake. A continuous current supply is required to keep a brake disengaged.

## Motor Brake Control Wiring

Certain motors used with the ViX drives can be fitted with a holding brake. This enables vertical (Z-direction) loads to be held whilst the motor is de-energised.

All brakes are fail-safe, that is you need to apply power to the brake to keep it disengaged. Removing power from a brake will engage or activate the brake preventing further shaft motion.

Figure 3-16 shows the connections necessary to control a motor holding brake. Power the brake from the 24V supply, a 2A fuse is recommended to protect the circuit from wiring faults. To release the brake, (allowing the motor shaft to turn) connect pin 1 of X1 to ground, using the manual BRAKE command.

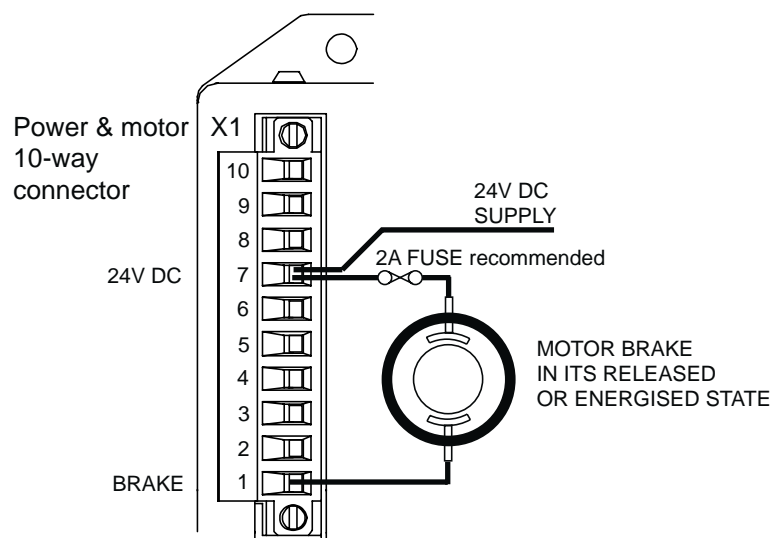

**Figure 3-16. Motor Holding Brake Connections**

See **Section 4. Control of ViX Drives - Brake Operation** for details of how to control its operation.

When a brake is used, the brake supply is dependent upon the value of HV.

For the majority of applications where the HV is greater or equal to 30V, the fused brake supply is taken from the 24V supply at X1 pin 7 (as shown above).

For applications where the HV is less than 30V, the brake supply can be taken from the motor HV supply at X1 pin 10.

Note: Whenever you change the HV supply you will need to run the motor configuration command. If there is no motor HV present, issuing the motor command assumes a value of 80V.

## X2 Connector

X2 provides the primary input connections for the motor feedback device.

### **Connector Type**

Connector type is a high-density 15-way D-type socket.

### **Connector Pin Out**

Connector Pin X2	Encoder
1	Incremental enc. Z+
2	Incremental enc. Z-
3	GND
4	reserved
5	+5V output
6	GND
7	Incremental enc. A-
8	Incremental enc. A+
9	Commutation f-b A0
10	Motor overtemp.
11	Incremental enc. B-
12	Incremental enc. B+
13	Commutation f-b A1
14	Commutation f-b A2
15	reserved

**Table 3-8. X2 Primary Feedback Connections**

## Encoder Compatibility

Devices supported: RENCO, Tamagawa

Signal format: quadrature 5V differential signals (A+, A-, B+, B-), Index mark Z+, Z-\*

Max input frequency: hardware limit 400KHz max. for A or B channel (1.6MHz post quadrature).

Definition of positive motion: A leads B when producing clock-wise motion as viewed at the motor output shaft.

Resolution: 500 to 5000 line devices supported (2000 to 20000 resolution).

### **Support of rotary and linear motors**

AH drives will support both rotary and linear motors with quadrature encoder feedback

For rotary motors with resolutions less than 20000 counts per rev, the alternative AE unit is recommended.



### **Commutation set up**

On energising the drive the commutation encoder input is captured and the torque vector set to be at the middle of the commutation segment..

Whilst rotating as soon as a commutation encoder edge is observed, the torque vector is realigned more accurately . After the first commutation edge is observed the commutation input channels are ignored. Prior to passing a commutation input edge the torque may be restricted to 87% of the peak torque available.

For a rotary motor more accurate alignment is made to the index mark. As soon as the index mark (Z input) is observed for the first time the torque vector is again more accurately set. If the Z mark is seen before the first commutation encoder edge the torque vector is set accurately and subsequent commutation transitions ignored

The above sequence of torque vector alignment is restarted on cycling through de-energising and energising the drive.

A Hall Effect commutation encoder signals are also used (refer to **Appendix B** for commutation details).

### **Following Encoder**

Hardware limit 2.0MHz maximum A/B channel input frequency, (8MHz post quadrature).  
5V differential.

### **Primary/Secondary Encoder 5V Supply**

X2 pin 5, X4 pin5.

Maximum loading 350mA TOTAL, using the above connections.

### **Motor Overtemperature Sensor**

The motor overtemperature switch input is compatible with thermal switches used in Parker SMB, SME, SM and BE servo motors. The input requires a normally closed switch to be connected to GND on X2 pin 3 or 6.

If you use a motor with no overtemperature sensor fitted or one with an incompatible thermistor sensor, make sure you un-check the 'Thermal sensor fitted' check box in **Custom Motor Set Up**, to prevent an overtemperature fault being reported.

### **X3 Connector**

X3 is the RS232 communications connector. RJ45 connectors X6 and X7 may also be used for inter-drive communications where multi-axis systems are used.

### **Connector Type**

Connector type is a 9-way D-type socket.

**Connector Pin Out**

Connector Pin X3	Function
1	Reserved
2	drive reset
3	RS232 GND
4	RS232 Rx
5	RS232 Tx
6	Reserved
7	RS232 Tx (D loop)
8	Do not connect
9	+5V output

**Table 3-9. X3 RS232 Connections****Baud Rate**

Use system variable BR to alter the baud rate of serial communications. Any change made to the baud rate will only take effect following a save (SV) and system reset (Z) or power cycle.

**Reset to RS232 Mode**

To reset the drive to RS232 mode and to return to factory settings, remove power from the drive, connect X3 pin2 to GND and restore power.

**CAUTION**

**This will erase ALL of your user settings and programs in volatile memory. The non-volatile memory will not be overwritten until a save command is issued.**

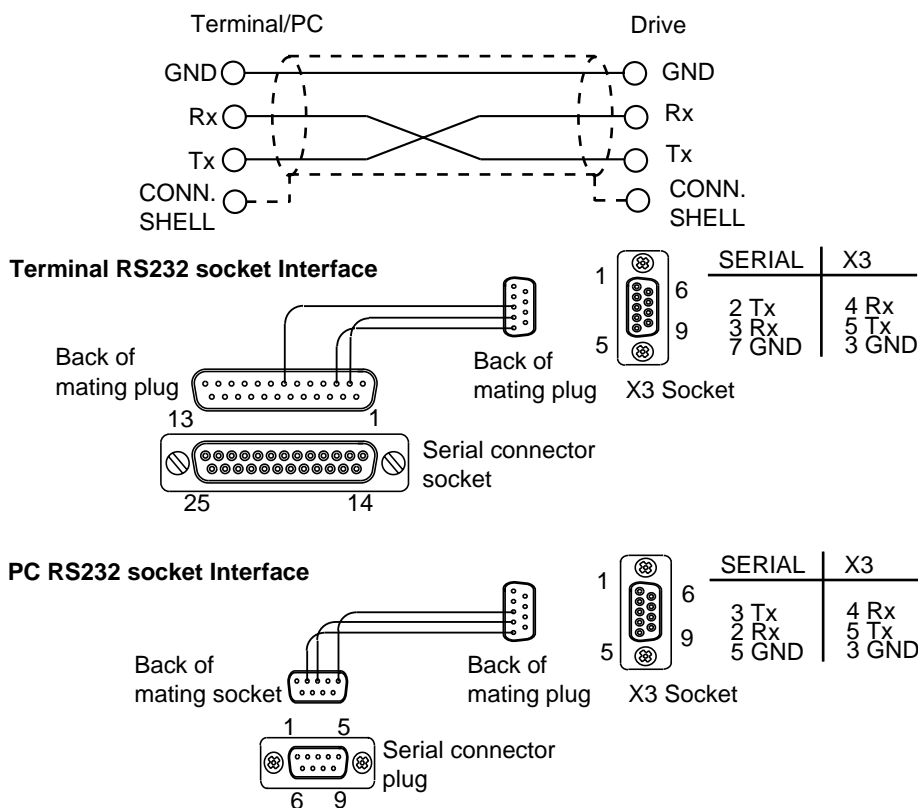

**Figure 3-17. X3 D-type Connector RS232 Connections**

### Inter-drive RS232 Connections

Use the RJ45 connectors X6 and X7 to inter-connect drives, see **RS232 Daisy Chain** later in this section.

#### **RS232 Connecting Leads**

RS232 cables can be ordered from Parker EMD. Various lengths are available as listed in Table 3-10.

<b>Part Number</b>	<b>Length</b>
RS232-EASI-0250	2.5m
RS232-EASI-0500	5.0m
RS232-EASI-0750	7.5m
RS232-EASI-1000	10.0m
RS232-EASI-1250	12.5m
RS232-EASI-1500	15.0m

**Table 3-10. RS232 Connection Lead Types**

## X4 Connector

Connector X4 gives access to the following encoder input and output signals and the differential analogue inputs. Input and output connections are dependent upon the state of system variables EO and EI.

### Connector Type

Connector type is a high-density 15-way D-type socket.

### Connector Pin Out

Connector Pin X4	Encoder I/O
1	ANA1+ (input)
2	ANA1- (input)
3	0V
4	/Z index (output)
5	Z index (output)
6	Fault (output)
11	Energise/* (input) Energise

\*See system variable ES

Table 3-11. X4 Encoder I/O Connections

### Inputs Depending Upon the State of System Variable EI

Connector Pin X4	EI=0	EI=1	EI=2
12	STEP+	CW+	A+
7	STEP-	CW-	A-
13	DIR+	CCW+	B+
8	DIR-	CCW-	B-

### Outputs Depending Upon the State of System Variable EO

Connector Pin X4	EO=0	EO=1	EO=2
14	STEP+	CW+	A+
9	STEP-	CW-	A-
15	DIR+	CCW+	B+
10	DIR-	CCW-	B-

**Encoder Input/Outputs**

Figure 3-18 shows the circuit details of the simulated encoder inputs and outputs. Note: /Z, Z channels have the same I/O circuits as the /A, A & /B, B channels.

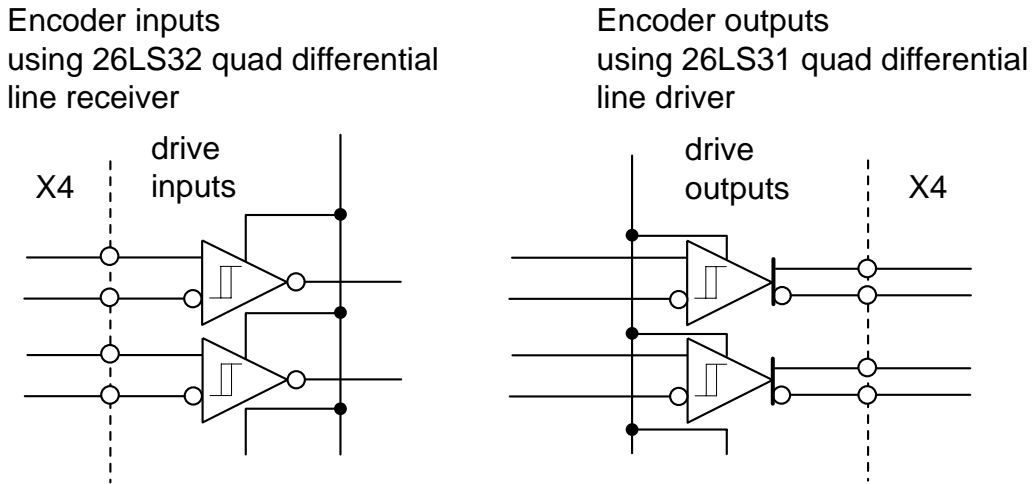

**Figure 3-18. Encoder I/O Circuit Details**

**Differential Analogue Input**

Control of the ViX base drive is via a differential analogue input. The input circuit, shown in Figure 3-19, can interface to an external +/-10V differential signal. Analogue to digital conversion (12-bit resolution) converts the analogue input to a digital value for use within the drive. The value of the analogue input can be read as a count via system variable AI.

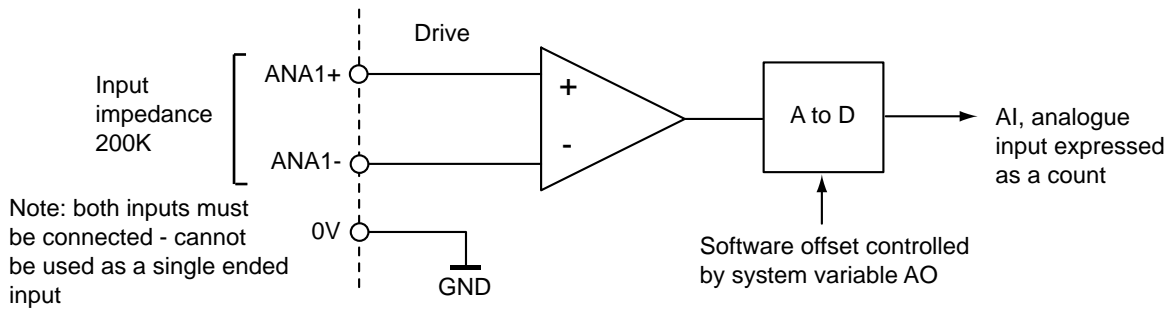

**Figure 3-19. Analogue Differential Input**

Figure 3-20 shows the input characteristic.

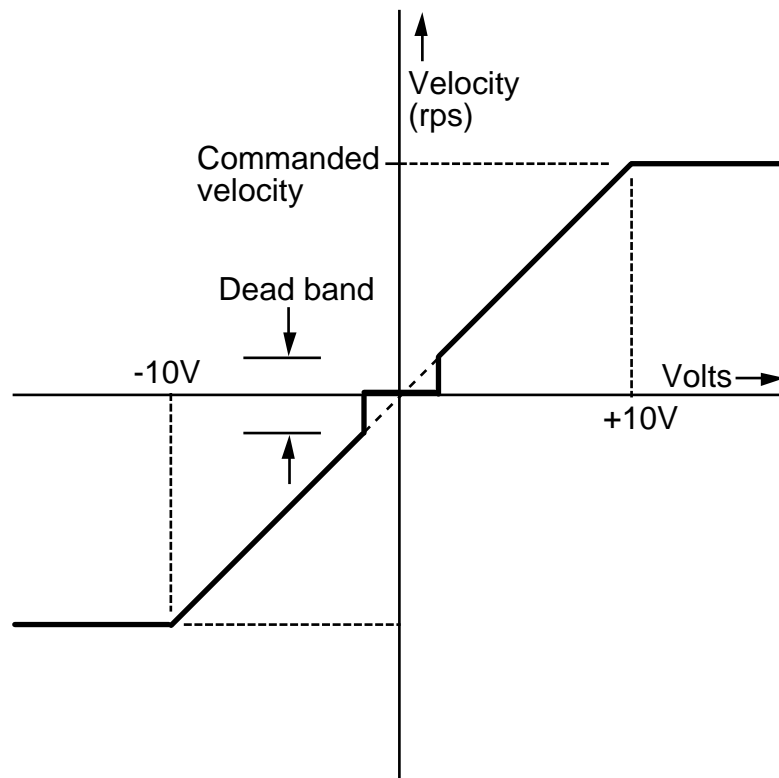

Figure 3-20. Analogue Differential Input Characteristic

### Fault Output

The fault output is an independent NPN open-collector output, which is normally 'low' active 'high'. The output ratings are +30V maximum in the OFF condition and 15mA maximum in the ON condition. Figure 3-21 shows the output circuit.

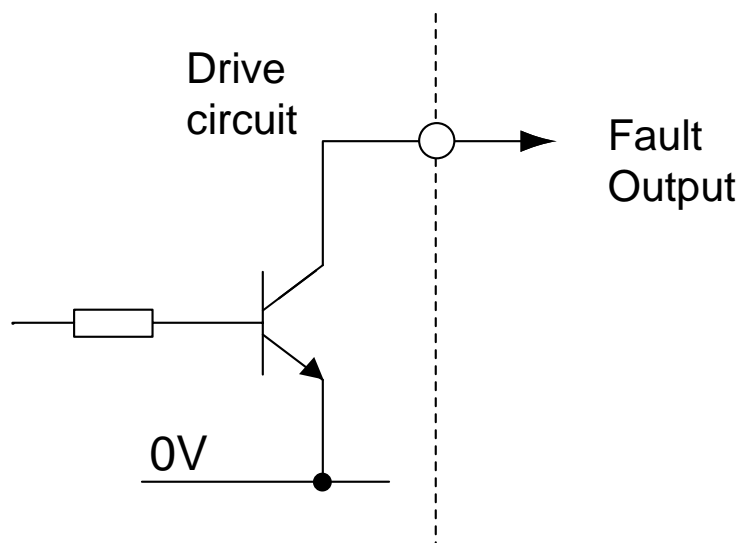

Figure 3-21. Fault Output Circuit

**Energise/Energise**

You can energise the drive by allowing this input pin to float high '1' or by linking the pin to zero volts, depending upon the input's polarity. System variable ES controls the polarity of this input. The default state of ES requires X4 input pin 11 to be connected to 0V to energise the drive.

**X5 Connector**

X5 is the user Input connector. On the base drive, one input is used to control the motor brake, if fitted.

**Connector Type**

Connector type is a high-density 15-way D-type plug.

**Connector Pin Out**

Connector Pin X5	Input/Output
1	0V
2	0V
3	0V
4	Reserved
5	Reserved
6	Reserved
7	Reserved
8	Reserved
9	Reserved
10	Brake IN
11	+24V
12	+24V
13	+24V
14	Reserved
15	Analogue monitor

**Table 3-12. X5 User Input/Output Connections**

**Brake Input Circuit**

Figure 3-22 shows the various input circuit arrangements of the brake control input, configured using system variable IC. You can drive this input from three output logic types:

- High logic level 24V source (IC = 256) (default)
- High logic level 24V sink (IC = 257)
- Low logic level 5V source (IC = 0)

**Do not attempt to drive this input with a low logic level (5V) sink output.**



When driven from a high logic level 24V source, a logic '1' (+24V logic) will engage the brake and a logic '0' (transistor off) will release the brake.

When driven from a high logic level 24V sink, a logic '1' or a high impedance state (transistor off) will engage the brake and an active pull-down to a logic '0' (transistor on) will release the brake.

Driving the input with a low level logic output, a logic '1' (transistor on) will engage the brake and logic '0' (transistor off) will release the brake.

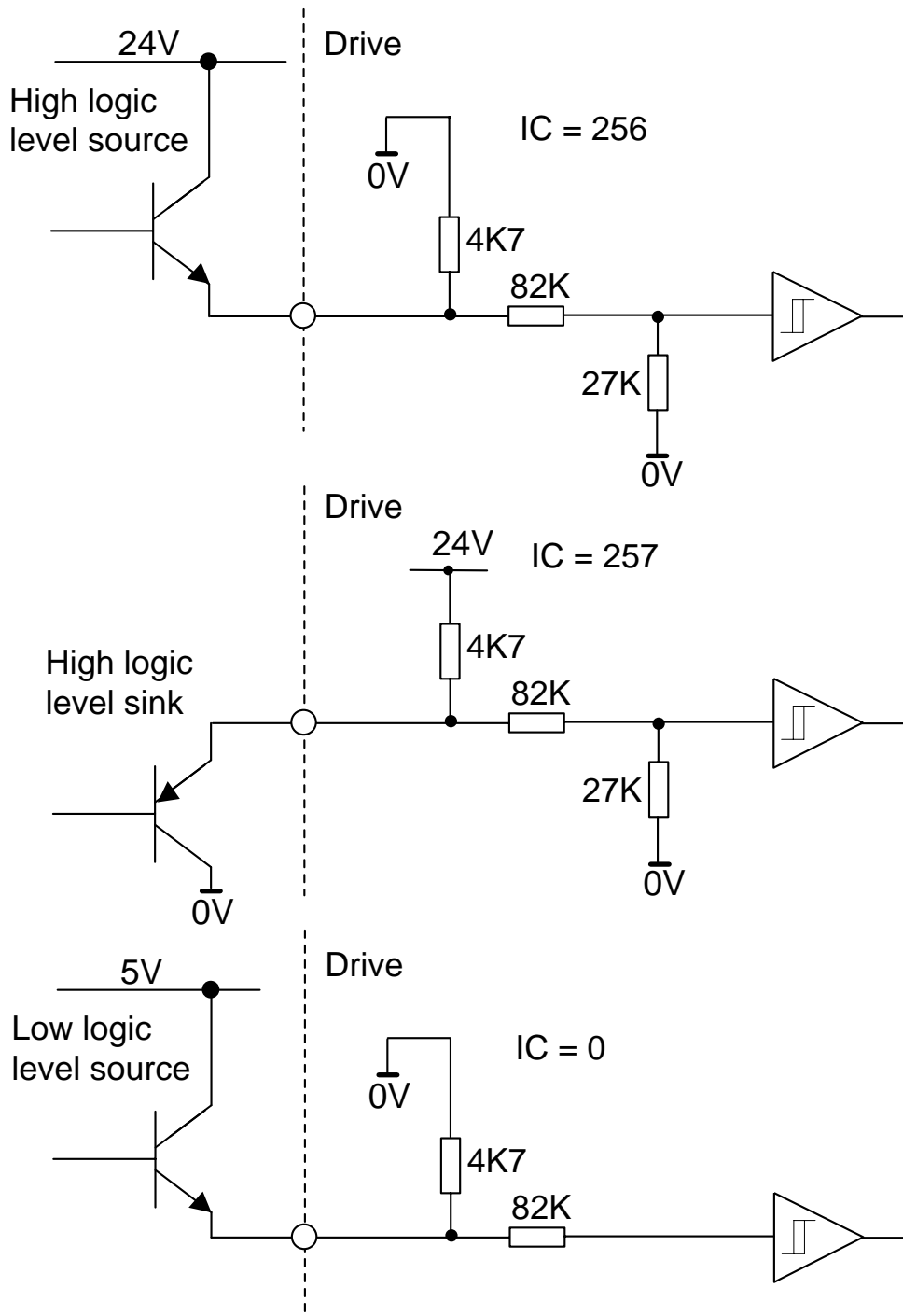
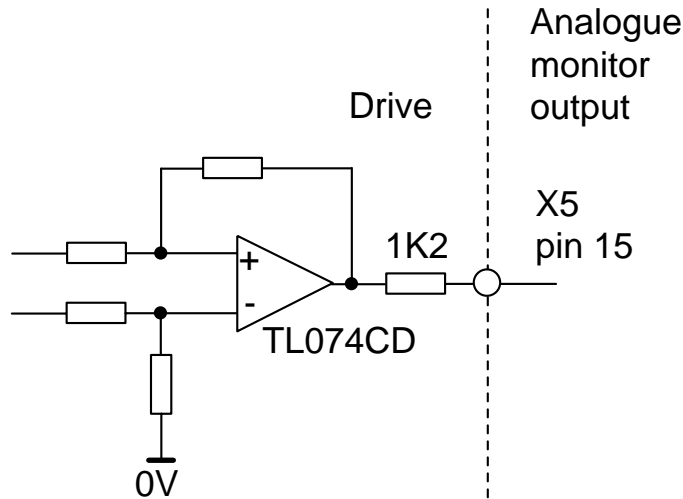

Figure 3-22. Brake Input Circuit

**Analogue Monitor**

The analogue monitor output on X5 pin 15 can be used to examine torque, velocity or a ramp test signal depending upon the setting of system variable AM. Figure 3-23 shows the circuit of the output.



**Figure 3-23. Analogue Monitor Output**

**RJ45 Interfaces**

Positioned beneath the drive are two RJ45 communication interfaces X6 and X7. The two interfaces provide support for daisy chain ports for multi-axis RS232 connections between drives.

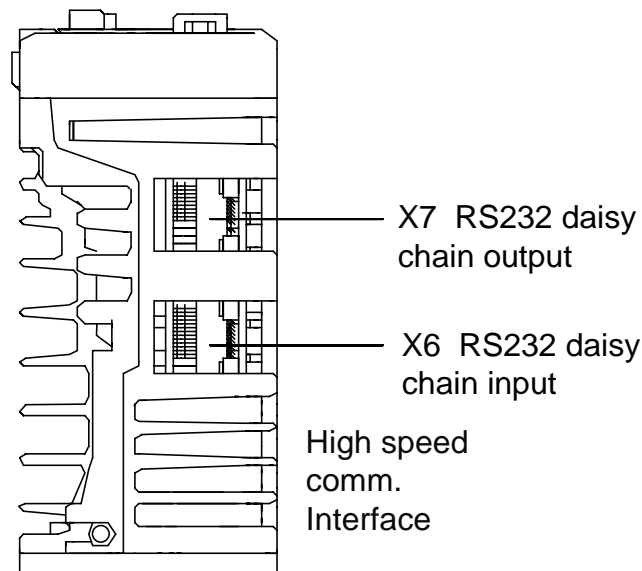

**Figure 3-24. Position of Connectors X6 and X7**

	<b>FEM1</b>	<b>CAT5 cable colours</b>
<b>X6</b>	<b>CANopen/RS485</b>	
1	RX+/TX+ RS485	White/Orange
2	RX-/TX- RS485	Orange
3	Reserved	White/Green
4	RS232 Gnd	Blue
5	RS232 Gnd	White/Blue
6	Reserved	Green
7	RS232 Tx	White/Brown
8	Rs232 Rx	Brown
<b>X7</b>		
1	RX+/TX+ RS485	White/Orange
2	RX-/TX- RS485	Orange
3	Reserved	White/Green
4	RS232 sense	Blue
5	RS232 Gnd	White/Blue
6	Reserved	Green
7	RS232 Rx	White/Brown
8	RS232 Tx	Brown

**Table 3-13. X6/X7 Input/Output Connections**

### Communication Daisy Chain

Drives can be 'daisy-chained' for RS232 operation as shown below. Using this arrangement the drive connected to the controlling PC, via its front panel D-type connector, becomes axis #1. To automatically assign addresses, connect all power, motor, feedback and communication cables then power-up all the drives, see '**#** command' for more details. At the controlling PC, type the following commands:

- #1** ;cause the 1<sup>st</sup> drive to establish the daisy chain  
*in a 3-axis system the response will be #4*
- 0SV** ;save the address configuration
- 0Z** ;reset  
*response should be a single check sum from axis 1  
more than one check sum indicates a problem, possibly no save command*

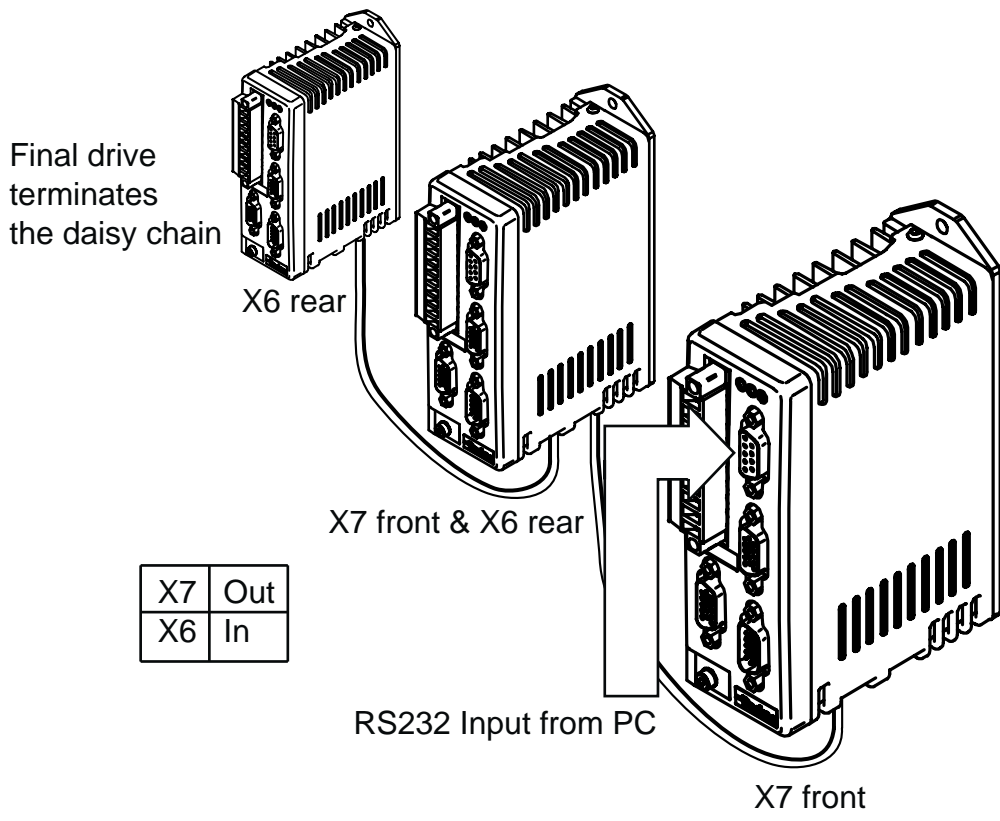

**Figure 3-25. RJ45 RS232 Daisy Chain Connections**

Using the X6/X7 connections on the underside of the drive will allow the last drive in the chain to detect that there are no more connections made to X7 which will close the daisy chain loop back internally.

***RJ45 Connecting Leads***

RJ45 link cables can be ordered from Parker EMD. Various lengths are available as listed in Table 3-14.

<b>Part Number</b>	<b>Length</b>
VIX-RJ45-0025	0.25m
VIX-RJ45-0050	0.5m
VIX-RJ45-0075	0.75m
VIX-RJ45-0100	1.0m
VIX-RJ45-0200	2.0m

**Table 3-14. RJ45 Connection Lead Types**

---



## 4. Control of ViX Base Drives

---

### Overview

This section introduces you to the operation of the ViX base servo drive. The drive uses a sub-set of ViX commands and system variables to support the drive when connected to an external controller or an analogue input. No programs can be stored in a base drive.

The drive uses RS232 serial communication to send commands to the drive and to receive status information back.

### Direct Mode

Direct operation of the drive is possible over a serial link from a PC or PLC. When used directly the drive will accept commands prefixed with the axis address and will action the commands as they are received.

---

### System Variables

System variables are named variables held within the drive's controller that are used for storing a variety of system values and settings. Read system variables using the Report system parameter (R command), but note, you can only write to certain variables using the Write (W command).

**Table of System Variables**

Table 4-1 lists system variables in alphabetic order together with their read/write status and range of values stored.

Var	Name	R	W	Range/default value
AB	Analogue Deadband	Y	Y	0 to +255, default = 0
AI	Analogue Input	Y	N	-2047 to +2047
AM	Analogue Monitor Mode	Y	Y	0 = torque monitor (default) 1 = velocity monitor 2 = outputs a triangular waveform -10V to +10V amplitude, with a 1 second period
AO	Analogue Offset	Y	Y	-2047 to +2047, default = 0
BR	BAUD rate	Y	Y	9600 (default) or 19200 bits per second
CL	Current Clamp	Y	Y	1 to 100% (default) of peak drive current
DF	Drive Fault status	Y	N	See reporting of drive faults DF1,2,3 & 4
EI	Encoder Input	Y	Y	0=step/dir (default), 1=cw/ccw, 2=quad ABZ, de-energise drive to change
EO	Encoder signal Output	Y	Y	0=step/dir, 1=cw/ccw, 2=quad ABZ (default), de-energise drive to change
ES	Energise Sense	Y	Y	Sets the sense of the external energise/energise_bar signal 0=low signal to energise (default) 1=high signal to energise
EX	Comms. Response Style & Echo Control & Physical Interface (RS232)	Y	Y	0= speak when spoken to, echo off, RS232 1= speak whenever, echo off, RS232 2= speak when spoken to, echo on, RS232 3= speak whenever, echo on, RS232 (default)
FT	Filter Time constant	Y	Y	0 to 255 used to filter high gain systems, measured in arbitrary units, default = 0
GF	Feedforward Gain (tracking)	Y	Y	0 to 1023 default = 5

**Table 4-1. List of System Variables**



Var	Name	R	W	Range/default value
GI	Integrator Gain (steady state)	Y	Y	0 to 1023 default depends on motor type
GP	Proportional Gain (stiffness)	Y	Y	0 to 1023 default depends on motor type
GV	Velocity feedback Gain (damping)	Y	Y	0 to 1023 default = 5
IC	Input/Output Configuration	Y	Y	Input pull-up/down, output source/sink configuration 0, 256 (default) or 257, for brake input only
IM	Integral Mode	Y	Y	0=continuous (default)
IW	Integral Window	Y	Y	default 50
IX	Index Pulse	Y	Y	0 to 1023, default=250, motor definition dependent
PA	Position Actual	Y	N*	-2,147,483,648 to 0 to 2,147,483,647, default = 0
PC	Peak Current	Y	Y	Sets maximum drive output value=scaling factor 100-400% of MC, default=300%
PE	Position Error	Y	N	+/- 32767
PF	Position Following	Y	Y	-2,147,483,648 to 0 to 2,147,483,647, default = 0
RV	ReVision of software	Y	N	x.yy major.minor
SN	Serial number	Y	N	Drive serial number
ST	Status of indexing	Y	N	See Reporting the Status of Variables ST1,2,3 & 4
TL	Tracking Limit	Y	Y	0-65535, defaults to Motor Resolution or Motor Resolution/100 if >65535
UF	User program Fault status	Y	N	See Reporting of user faults UF1,2,3 & 4

\*Can be set to 0 only.

**Table 4-1. List of System Variables (Continued)**

***AB, AI and AO Description***

AB controls the dead band and AO the offset of the differential analogue speed/torque control input. See ***Differential Analogue Input*** in the ***Electrical Installation*** section.

***AM Description***

Use output 4 (X5 pin 15) to output an analogue DC voltage between +10V and –10V to represent the velocity or torque being generated by the drive, depending upon the setting of system variable AM. Setting AM to 2 generates a bipolar triangular waveform with a time period of 1 second.

***BR Description***

This sets the Baud rate of serial communications. Enter the required Baud rate directly, for example **aW(BR,19200)** to set the rate to 19200. You will need to save this setting and then reset the drive (Z command) or cycle the power before the change will take effect.

***CL and PC Description***

See ***Motor Related System Variables*** in the ***Electrical Installation section***.

**DF Description**

See drive fault bit description in *Reporting the Status of Variables*.

**EO Description**

Use encoder outputs (connector X4) to supply a step-direction or step-up/step-down signal for use by another drive. System parameter EO determines the output as defined in Table 4-2.

X4	EO=0	EO=1	EO=2
14	STEP+	CW+	A+
9	STEP-	CW-	A-
15	DIR+	CCW+	B+
10	DIR-	CCW-	B-

**Table 4-2. Encoder Output Configuration**

**EI Description**

System parameter EI, controls encoder inputs (connector X4) as defined in Table 4-3.

X4	EI=0	EI=1	EI=2
12	STEP+	CW+	A+
7	STEP-	CW-	A-
13	DIR+	CCW+	B+
8	DIR-	CCW-	B-

**Table 4-3. Encoder Input Configuration**

**CAUTION**

**De-energise the drive before changing EI and EO.**

**ES Description**

System variable ES controls the required polarity of signal on the energise/energise\_bar input (X4 pin 11). The default value of ES is zero (ES=0), therefore to energise the drive connect X4 pin 11 to X4 pin 4 (0V). With ES=1, X4 pin11 may be left open circuit to energise the drive.

**EX Description**

System variable EX controls the style and protocol of the drive's serial communications link.

**FT Description**

Fast positioning systems need high proportional and velocity gains. By limiting the bandwidth, the digital filter prevents a high gain system from becoming too lively. The filter

also serves to average the effects of the digital control loop, reducing the jitter at standstill and the audible noise. The value of FT should be kept as low as possible. The arbitrary units used to set the value of FT cannot be directly related to any time value.

### ***GF Description***

The opposing action of proportional and velocity gains result in a position error which depends on speed. This is called 'following error'. Feedforward gain can be used to offset the following error and improve tracking accuracy. This is important in contouring applications.

### ***GI Description***

Proportional action may be insufficient to overcome static position errors caused by gravitational load effects. Integral action accumulates a steady state error until sufficient torque is produced to move the load. It improves overall positioning accuracy but may produce low frequency oscillation around the commanded position.

### ***GP Description***

Proportional gain determines the amount of torque produced in response to a given position error. It sets the stiffness of the system and affects the following error. A high proportional gain gives a stiff, responsive system but results in overshoot and oscillation that require damping.

### ***GV Description***

Velocity feedback is a signal which increases with shaft speed. It acts in a negative sense opposing the proportional action and helping to stabilise the motion. The damping action of velocity feedback allows a higher proportional gain to be used.

### ***IC Description***

System variable IC sets the configuration of the drive's brake input circuit – see '***Brake Input Circuit***' in the ***Electrical Installation*** section.

### ***IM and IW Description***

Integral mode determines when integral action (GI) is applied, either continuously or within a integral window defined by IW.

### ***IX Description***

System variable IX determines the position of the index pulse relative to phase U (or phase 1) of the drive. Altering the position of the index pulse allows compatibility with different motor types. Incorrect settings will result in uncontrollable motion.

### ***PA Description***

PA reports the actual position of the motor shaft. Although PA is marked as being read only it will accept the value 0 to be written to it for resetting purposes. If you perform a **W(PA,0)** system variables PF, PE and PT will also be set to 0. However, if you immediately perform a read of these system variables non-zero values will be reported due to normal servo action.

**PC Description**

See *Motor Related System Variables* in *Electrical Installation*.

**PE Description**

PE reports the position error, that is, the difference between PT and PA.

**PF Description**

PF reports the position fed-back by a remotely mounted encoder for following applications.

**RV Description**

Reports the revision of software being used by the controller.

**SN Description**

Reports the serial number of a drive.

**ST Description**

See reporting of status bits in *Reporting the Status of Variables*.

**TL Description**

Tracking limit is the maximum amount of position error that can be tolerated, if PE exceeds TL a fault will be reported.

**UF Description**

See reporting of user fault bits in *Reporting the Status of Variables*.





Bit Number	Stop	Type	DF Information
1			Composite fault (anything that causes a drive fault)
2	K	T	+/-15V supply rail
3	K	R	Motor HV under-voltage trip point reached
4	K	R	Motor HV over-voltage trip point reached
5	C	R	V I/O under-voltage trip point reached
6	C	R	V I/O over-voltage trip point reached
7	K	T	Encoder/Auxiliary 5V under voltage trip
8	K	T	Impending power loss (24V – logic supply)
9	K	T	Commutation Fault
10	-	-	N/A
11	C	R	Motor over temperature
12	C	R	Ambient over temperature
13	C	R	Drive over temperature
14	K	T	Incompatible firmware version
15	K	T	Unrecognised power stage
16	K	T	Controller diagnostic failure
17	K	R	Output stage over current
18	C	R	Output driver over current
19	C	R	Tracking limit exceeded while in motion is a latched fault
20	K	R	Velocity exceeded (unstable gains/motor spin-off)
21	C	R	Energise input not set – check energise input and state of ES variable
22-24			Reserved
25	K	T	Watchdog 1
26	K	T	Watchdog 2
27	K	T	Watchdog 3

**Table 4-5. Drive Fault Bit Description**

Key: C: Performs controlled stop  
 K: Performs motion kill – quick stop. Possible instant de-energise depending on fault source  
 R: Recoverable without power cycle  
 T: Terminal (requires power cycle or repair before drive will energise/operate again)

### ***Drive Fault Byte Reporting***

In exactly the same way as the status variable, the drive fault status can be reported a byte at a time, using **DFn** within a read command.



**User Faults**

Programming errors, such as issuing a GO command when the drive is de-energised can cause user faults. The report uses a 32-bit word format the same as Drive Faults.

Performing a read UF command will report the current state of any User Faults listed in Table 4-6.

Bit Number	UF Information
1	Value is out of range
2	Incorrect command syntax, command has wrong format
8	Drive de-energised
16	Transmit buffer overflow*
19	Drive not ready
22	Save/restore error
23	Command not supported by this product
26	Cannot execute motion as the brake is engaged
27 to 32	Reserved

**Table 4-6. User Fault Bit Description**

\*sends an ASCII 'bell' character to indicate a buffer overflow condition.

**User Fault Byte Reporting**

In exactly the same way as the status variable, the user fault status can be reported a byte at a time, using **UFn** within a read command. For example to read or test the first 8 bits (first byte) of the UF variable status word, use UF1. Since the status word consists of 4 bytes the relevant part of the word can be read using UF1 (bits 1 to 8), UF2 (bits 9 to 16), UF3 (bits 17 to 24) or UF4 (bits 25 to 32).

**Resetting User Fault Bits**

The User Fault variable (UF) is cleared to all zeroes once it has been read by issuing a **aR(UF)** command. Reading individual bytes of the User Faults variable will not clear any particular byte, so issuing a **R(UF2)** command will keep byte 2 bits intact. Also testing a particular byte using the **IF** or **TR** command will keep bits intact.

Note: sending the drive an **ON** command will immediately clear the User Fault variable, setting all four bytes to 00000000.

### Servo Control Loop

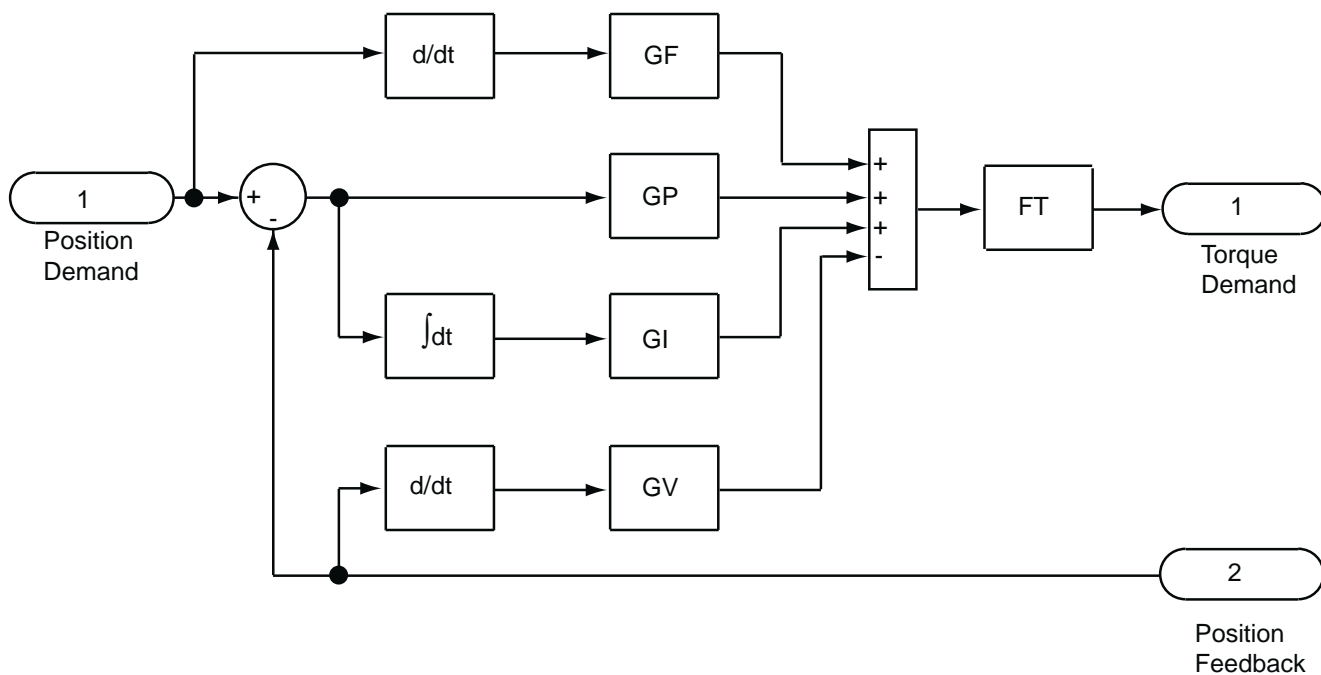

Figure 4-1. ViX Servo Control Loop

## Controlling the Drive's Mode of Operation

### Mode

Operation of the ViX base drive is possible in three different modes, controlled by the M (Mode) command. These are:

- Base servo position mode
- Base servo torque mode
- Base servo velocity mode

### **Base servo position mode**

This mode uses the servo step and direction inputs to control the drive. Figure 4-2 shows a 6K controller, used for step/direction purposes. A single multi-core cable links the 6K and ViX with the connections listed in Table 4-7.

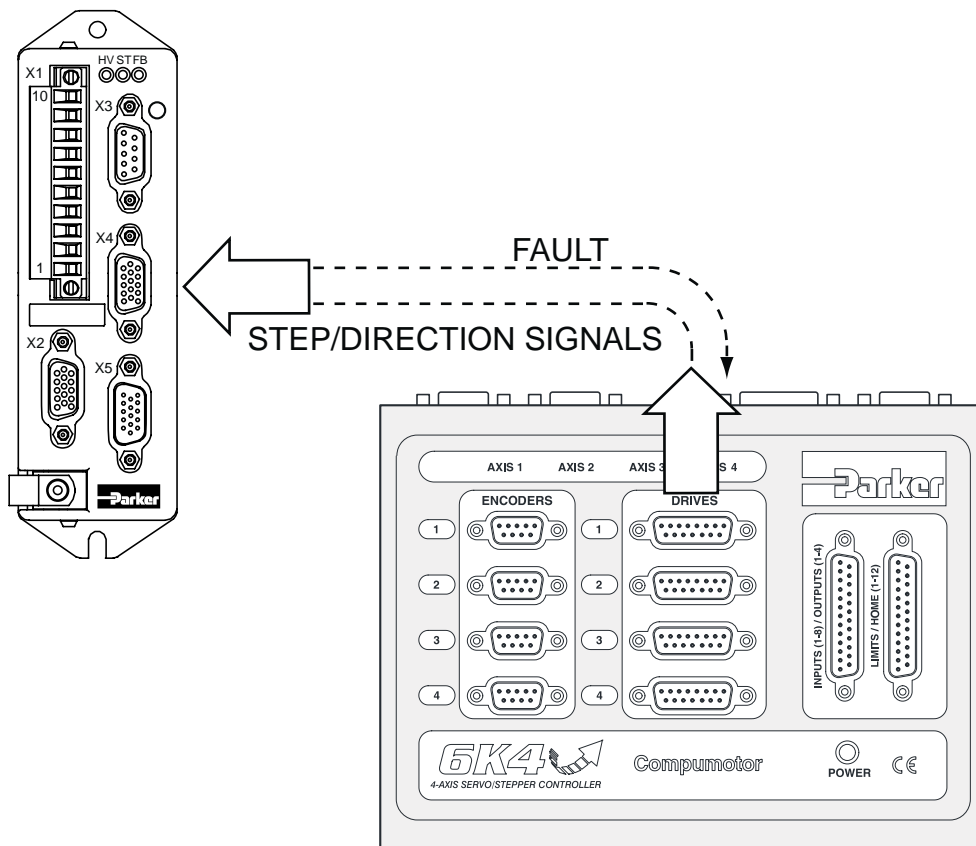

Figure 4-2. Base Servo Mode Using Step/Direction Control

**Connections**

6K Drive connector	Description	ViX X4 connector	Description
1	Step +	12	A +
2	Direction +	13	B +
5	Fault	6	Fault
7	Shutdown (NO)	11	Energise
9	Step -	7	A -
10	Direction -	8	B -
*13/14	Isolated Gnd/Shutdown (COM)	3	Gnd

\*Pins 13 and 14 should be connected together at the 6K

**Table 4-7. Step/Direction Connections**

The CNTRL-P terminal on the 6K should be connected to +24V DC.

**Commands**

For the ViX drive issue the following commands:

```

1MP                ;Mode Position (Step & Direction)
1W(ES,0)           ;Energise input active level
1W(EI,0)           ;Set input for step/direction
1SV                ;Save settings
    
```

A valid MOTOR command is required.

GAINS all need to be used to tune the PIVF loop.

For the 6K4 issue the following commands:

```

AXSDEF0000           All axes are steppers
ERES8000,8000,8000,8000  Should match ViX motor resolution
DRES8000,8000,8000,8000  Should match ViX motor resolution
DRFLVL1111          Drive fault active level
DRFEN1              Enable drive fault detection
LH0,0,0,0           Disable limits (optional)
    
```

```

A...
V...
D...
GO1                  Execute move
    
```

**Base servo torque/velocity mode**

This mode uses the servo analogue inputs to control the drive. Figure 4-3 shows a 6K controller, used for control purposes. A double multi-core cable links the 6K and ViX with the connections listed in Table 4-8.

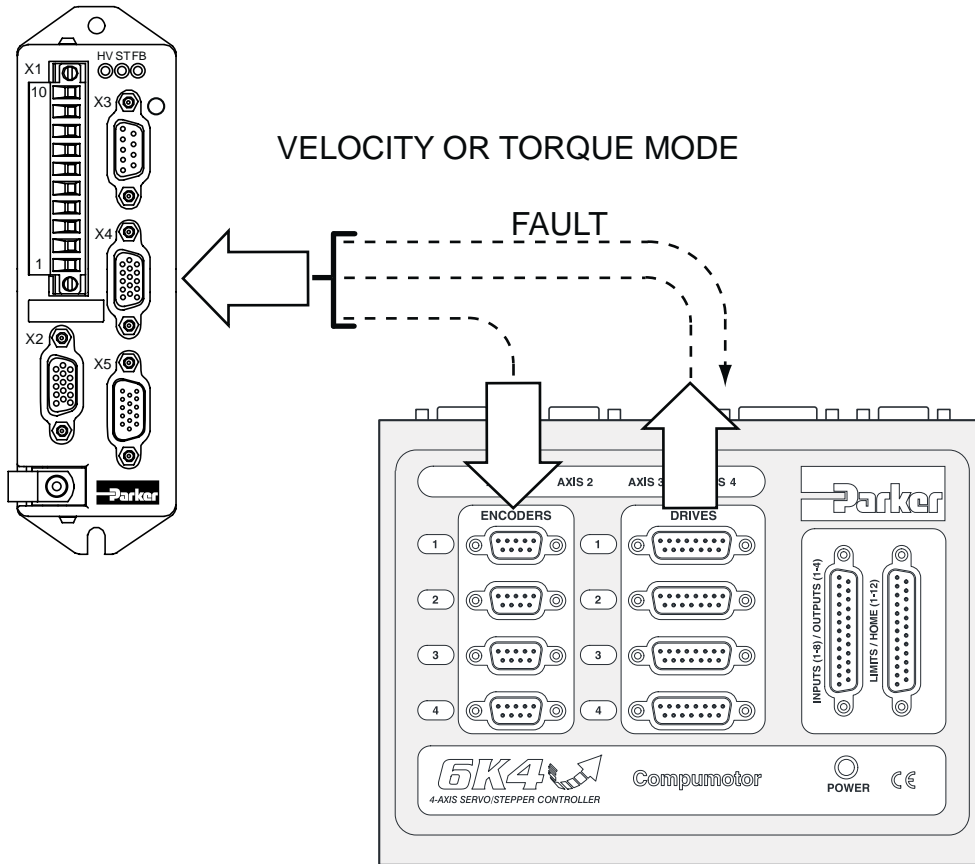

**Figure 4-3. Base Servo Mode Using Analogue Input Control**

**Connections**

ViX X4 connector	Description	6K connectors	Description
1	Ana1+	3 - Drive	Command +
2	Ana1-	6 - Drive	Command -
3	0V	9 - Drive	Isolated Gnd
6	Fault	5 - Drive	Fault
9	A- out	3 - Encoder	A -
10	B- out	5 - Encoder	B -
11	Energise	7 - Drive	Shutdown (NO)
14	A+ out	2 - Encoder	A +
15	B+ out	4 - Encoder	B +

**Table 4-8. Velocity/Torque Mode Connections**

\*Pins 13 and 14 on the 6K DRIVE connector should be connected together.

The CNTRL-P terminal on the 6K should be connected to +24V DC.

**Velocity Mode Commands**

For the ViX drive issue the following commands:

```

1MV           ;Mode Velocity
1W(ES,0)      ;Energise input active level
1SV           ;Save settings
    
```

A valid MOTOR command is required.

At least some feed-forward and velocity gain needs to be used to tune the PIVF loop, that is GF=GV=5.0.

For the 6K4 issue the following commands:

```

AXSDEF1111      All axes are steppers
ERES8000,8000,8000,8000  Should match ViX motor resolution
DRFLVL1111     Drive fault active level
DRFEN1         Enable drive fault detection
LH0,0,0,0      Disable limits (optional)
TGAIN          Read all gains
SGP            Set proportional gain
SVG           Set velocity gain

A
V
D
GO1           Execute move
    
```

**Torque Mode Commands**

For the ViX drive issue the following commands:

<b>1MT</b>	;Mode Torque
<b>1W(ES,0)</b>	;Energise input active level
<b>1GAINS(0,0,0,0,0)</b>	;Zero all gains
<b>1SV</b>	;Save settings

A valid MOTOR command is required.

All GAINS need to be 0.0

For the 6K4 issue the following commands:

<b>AXSDEF1111</b>	All axes are steppers
<b>ERES8000,8000,8000,8000</b>	Should match ViX motor resolution
<b>DRFLVL1111</b>	Drive fault active level
<b>DRFEN1</b>	Enable drive fault detection
<b>LH0,0,0,0</b>	Disable limits (optional)
<b>TGAIN</b>	Read all gains
<b>SGP</b>	Set proportional gain
<b>SVG</b>	Set velocity gain

A

V

D

GO1

Execute move

## Brake Operation

ViX drives have the ability to control a motor holding brake via the X1 pin 1 motor brake output. Note, special conditions apply to the brake wiring depending upon the brake supply used, see **Motor Brake Control Wiring** in the **Electrical Installation** section.

Before describing the various braking modes, note the following assumptions:

- The automatic brake functions only operate if a motor with a brake has been set up using the MOTOR command.
- The brake output is not controllable by software when the drive is initially powered-up, whilst in the process of resetting or when powered off. Under these conditions the brake output should be off and the brake, therefore applied.

The automatic part of the brake command uses two timers ED and RD to make sure the drive holds position while the brake is released and the brake holds position before the drive is de-energised. Figure 4-4 shows the operation of the two timers.

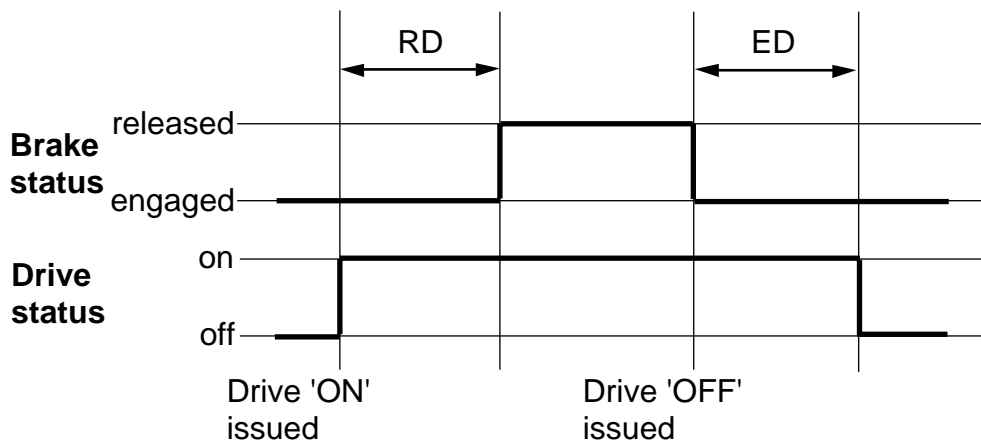

Figure 4-4. Brake Command Operation of Timers RD & ED

### Automatic Braking (Holding Brake)

Energising the drive starts a timer that counts down to a pre-determined count RD (Delay to Release) at which point the brake disengages leaving the drive to hold position. When you instruct the drive to de-energise the controller will engage the brake and start a further counter ED (Delay from Engage). Once ED times out, the drive de-energises leaving the brake to hold position.

### Automatic Braking (Dynamic Brake)

This option works in a similar way to the automatic holding brake. In this case, a drive fault that de-energises the drive's power stage under hardware control will apply the brake as soon as the software detects the fault condition. The pre-programmed delay time is ignored.



## External Brake Control

The base drive (AE version) has a dedicated input (X5 pin10) used for external control of the brake. This input can be driven from a high-level logic source or sink, or a low-level logic source, see ***Brake Input Circuit*** in ***Electrical Installation*** section. A logic high input is required to apply or engage the brake, the brake will react immediately with no delay or check for motor movement. Select mode E using the BRAKE command to make use of this external input.

Use this form of brake control with caution, since careless or accidental application of the brake could lead to physical damage of the brake components.

### ***Default Brake Command***

For the base drive, the BRAKE default setting is all brake modes disabled.

## Other Factors that Influence Braking Operation

In addition to the modes of brake operation, certain drive conditions influence brake behaviour, these are:

- State of enable input
- Resetting the drive
- 24V power failure
- Drive fault

## Enable Input

Even if the motor is moving, setting the enable input to disable would immediately disable the drive's power stage. If the automatic dynamic brake mode is set, the brake is applied as soon as the controller detects the drive is de-energised (nominally within 500 microseconds). If the input is subsequently re-enabled, the brake remains applied until released by a valid control method.

## **Reset (Z)**

Issuing a reset will engage the brake, at least momentarily, as the system fails safe. Subsequently, the following will happen:

- The brake will remain applied in automatic mode until the drive is re-energised.
- The brake will be released if the MOTOR command indicates no brake is fitted.

## **24V Power Failure**

A dip in the +24V supply will turn off the drive's controller, which in turn will apply the brake. Cycle the 24V supply to re-start the controller.

If you expect this to happen during motion, use dynamic brake control, assuming that a dynamic brake is fitted.

## **Drive Fault**

You may program application of the brake during a fault routine.

For both automatic brake modes, if a fault generates a controlled stop, the brake is applied when commanded motion stops, and before the drive is de-energised.

---

## 5. Easi-V Software

---

### Computer Requirements

To be able to run Easi-V software, necessary for the control and programming of the ViX, you will require an IBM™ compatible PC running Windows 95/98/2000/XP™, NT4 or ME.

The PC needs to be specified to run Windows™ with at least 16MB of RAM, a VGA monitor, Windows™ compatible mouse, CDROM drive. The installed program size is approximately 1.3MB. Easi-V is supplied on a CD or may be downloaded free of charge from our Website ([www.parker-emd.com](http://www.parker-emd.com)).

### Serial Link Lead

You will need a **2-wire plus ground** lead which has the **Rx and Tx wires crossed over**. Wiring details are given in the *Electrical Installation* section.

**Note:** The information contained within this section applies to Easi-V software version 3.0 or greater. If you have an earlier version of Easi-V software please request the latest version from Parker EMD using the contact numbers given at the beginning of this user guide or download a copy from our web-site ([www.parker-emd.com](http://www.parker-emd.com)).

### Compatibility of EASIV

Always use the latest version of Easi-V, available from our web-site or supplied with the product.

## Establish Communications

Before attempting communication with the drive the supplied software needs to be installed on to the PC's internal hard disk drive. Once software installation is complete, commands can be downloaded from the PC to the drive to confirm its operation. If Easi-V has already been loaded you may skip the following Installation and Operation sections up to **Confirming Drive Operation**.

## Software Installation

Before attempting to install the EASI-V software supplied with your drive check that your PC meets the requirements previously defined under **Computer Requirements**.

EASI-V software is supplied on a CDROM and installs in the usual manner common to Window™ applications.

## Installation Procedure

This procedure takes you quickly through the steps necessary to install Easi-V on your PC. The entire installation process takes less than 10 minutes. Before starting the installation, terminate all applications currently running.

A step by step installation of Easi-V software follows:

1. Place the Easi-V CD in your PC's CDROM drive.
2. Once loaded the CD should auto-start. If this does not happen, open the CD's folder and double-click the **EMD.exe** icon.
3. Follow the on-screen instructions to load Easi-V.
4. The screen will display the Easi-V program banner and will prepare an installation setup program.
5. The banner screen is automatically replaced by a Welcome dialogue box advising you of the need to exit any programs currently running. To abandon setup in order to exit other programs, select CANCEL. This in turn displays an Exit Setup dialogue box giving you the options of Exit Setup, which returns you to Windows™ or Resume which takes you back to the Welcome box.
6. Selecting NEXT> displays a 'Choose Destination Location' dialogue/selection box that provides the option of installing Easi-TOOLS in the directory of your choice. The default directory is **c:\program files\parker\EasiV** in the UK, but the exact path name is country dependent, other buttons are described within the dialogue box, see Figure 5-1.



**Figure 5-1. Choosing Where to Install Easi-V**

6. Once you have selected a destination for Easi-V or have decided to use the default directory, select NEXT to begin file transfer.

7. Once Easi-V has been loaded, the screen will display a message dialogue box, stating 'Setup is complete. You may run the installed program by double-clicking on the program icon.' When you click the OK button, the window shown in Figure 5-2 will appear. Note: Easi-V may also be run from the Start menu.

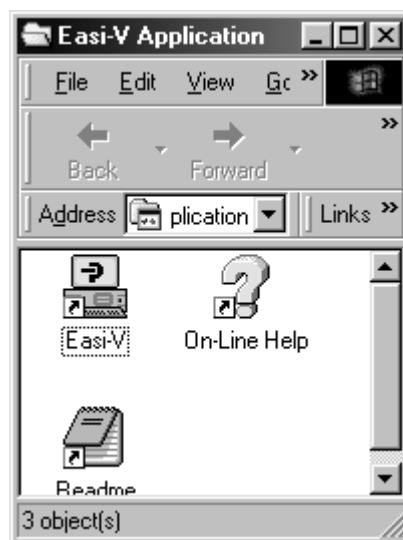

**Figure 5-2. Easi-V Application Window**

## Uninstalling Easi-V

To uninstall Easi-V software, use Windows™ uninstall software facilities available within the Control Panel. All components are removed.

## Software Operation

Once installed, Easi-V can be started from the start menu or by double clicking its application icon. At startup Easi-V displays the product selection screen shown in Figure 5-3. When using rotary motors make the selection shown.

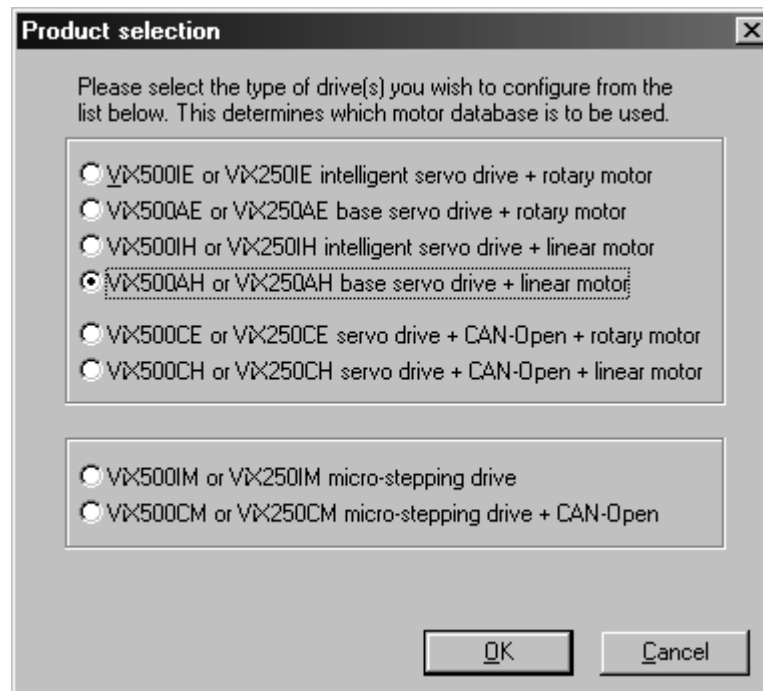

**Figure 5-3. Easi-V Product Selection**

Selecting Product from the Utilities menu will also display the product selection screen.

Selecting OK will display the main application window, entitled 'Parker Hannifin EMD – Easi-V', and seven pull-down menus become available:

File, Edit, Search, Terminal, Utilities, Windows, Help

The majority of options available within each menu are familiar to Window™ users and will not be fully described here, but options available within Terminal and Utilities are specific to drive control and will be fully described.

## Menu Overview

### File

<u>N</u> ew	Ctrl+N
<u>O</u> pen...	Ctrl+O
<u>S</u> ave	Ctrl+S
Save <u>A</u> s...	
<u>P</u> rint...	Ctrl+P
<u>C</u> lose Window	
<u>E</u> xit	Alt+F4

### Filing Operations

- Creates a new editor file, or .prg program file
- Opens an existing editor file or program
- Save an editor file
- Save an editor file specifying the file name
- Print the editor file or contents of terminal buffer
- Close current active window
- Exit Easi-V

### Edit

<u>U</u> ndo	Ctrl+Z
<u>C</u> ut	Ctrl+X
<u>C</u> opy	Ctrl+C
<u>P</u> aste	Ctrl+V
<u>C</u> lear	Del
<u>S</u> elect All	
<u>G</u> o to line	Ctrl+G

### Editing Operations

- Undo a previous edit (1 level of undo only)
- Remove highlighted text to clipboard
- Copy highlighted text to clipboard
- Paste contents of clipboard to current cursor location
- Delete highlighted text
- Highlight all text in active editor file window
- Go to a particular line within a file\*

### Search

<u>F</u> ind...	
Find <u>N</u> ext	F3
<u>R</u> eplace...	

### Editor search & replace operations

- Find specified text (top down from cursor position)
- Repeat search again
- Find and replace text (top down from cursor position)

\* Selecting 'Go to line' from the edit menu will generate the following dialogue box, which allows the required line number to be entered. This is useful for locating errors when loading a program.

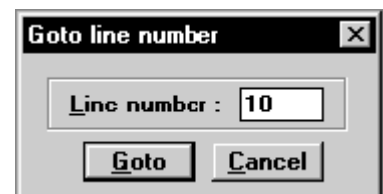

## Terminal

<u>S</u> ettings	
<u>C</u> onnect	
Configure terminal <u>b</u> uttons	F2
<u>E</u> dit buffer	
<u>L</u> og to file	

### Terminal on-line operations

- Configure the serial communications
- Open/close the terminal (after testing the connection)
- Configure test buttons
- [Edit buffer]** Create an editor file window or terminal buffer
- [Log to file]** Open/close file logging terminal buffer actions

## Utilities

<u>P</u> roduct	
<u>G</u> uided servo setup	
<u>S</u> ervo setup	
<u>A</u> xis <u>s</u> tatus	
<u>D</u> ownload program to drive	F4
<u>U</u> pload program from drive	F5
<u>D</u> rive <u>L</u> EDs	

### Specific tools

- Displays Product Selection screen
- Help screens guide you through servo setup
- Similar to above, but uses tabbed text boxes
- Display status bits or messages
- [Download program to drive F4]** Download program
- Upload program
- Displays LED diagnostics sheet, colour & flash rate

## Windows

<u>T</u> ile	F6
<u>C</u> ascade	F7
<u>N</u> ext	F8
Arrange <u>I</u> cons	
Close <u>A</u> ll	
✓ <u>1</u> Editor - EXAMPLE5.PRG	

### Window controls

- Share program desktop space between open windows
- Cascade all open windows on program desktop
- Select/activate the next window
- Arrange all minimised windows on program desktop
- Close all active windows on program desktop

## Help

<u>C</u> ontents	F1
<u>S</u> earch for...	
<u>I</u> ndexer commands	
Visit <u>P</u> arker-EMD online	
<u>T</u> echnical support	
<u>S</u> ales support	
<u>A</u> bout...	

### Program help facilities

- Open help file at the main contents (start)
- Prompt for topic string and search help file
- Open help for individual EASI-V commands
- Visit Parker web-site
- E-mail Parker technical support
- E-mail Parker sales support
- EASI-V version number and copyright



## Terminal Menu Selections

Terminal menu selections control the setup and configuration of communication between a PC and drive.

## Communicating with a Drive

The default settings of a new drive from power-up are RS232 communications with an address setting of #1. Wire the RS232 communication lead as described in the Electrical Installation section.

### WARNING

**To avoid causing damage to a PC serial port the drive must be earthed before making any serial connections.**

Connect the RS232 lead between the drive's X3 socket and the controlling PC's RS232 connector.

## Configure the serial communications

From the Terminal menu choose Settings to display the following Communications port configuration dialogue box.

The default settings used are:

Port	COM1
BAUD rate	9600
Options	Auto wrap

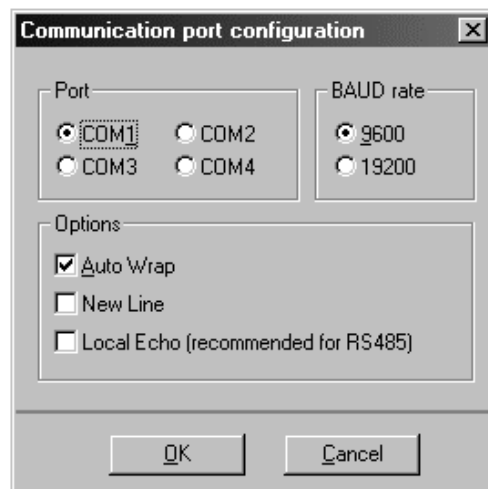

Figure 5-4. Comms Port Configuration

Select the required configuration and, click OK. Then, again from the Terminal menu select Connect to start communications. Every time Connect is issued the communications link is tested to establish it is working correctly and the message box 'Testing communications integrity' is flashed on the screen, followed by 'Now on-line to controller' if the Connect is successfully made. If the link fails, refer to the Troubleshooting Section. Note: The baud rate selected must agree with the drive's hardware selected value.

### **Configure Terminal Buttons**

The Terminal menu has a 'Configure terminal buttons F2' command which generates a terminal buttons configuration window.

This allows you to add buttons to the base of the Terminal window and assign a keyboard shortcut to each button added, depending upon where it appears in the list order. This facility enables a group of commonly used commands to be sent to a drive(s) by clicking a single button in the Terminal window or pressing a Shift/Function key combination from the keyboard.

## Utilities Menu Selections

Utilities menu selections control the way drives are setup and configured for use with a particular motor type. The menu offers two levels of setup, depending upon the skill and experience of the operator.

- Guided servo setup (guides you through setup for a particular motor type – quick and simple)
- Servo setup (allows text entry of motor parameters – for experienced users)

From the Utilities menu select 'Guided servo setup'.

Select the axis address of the drive to be initialised. In this case the default value of #1 can be used for initial testing.

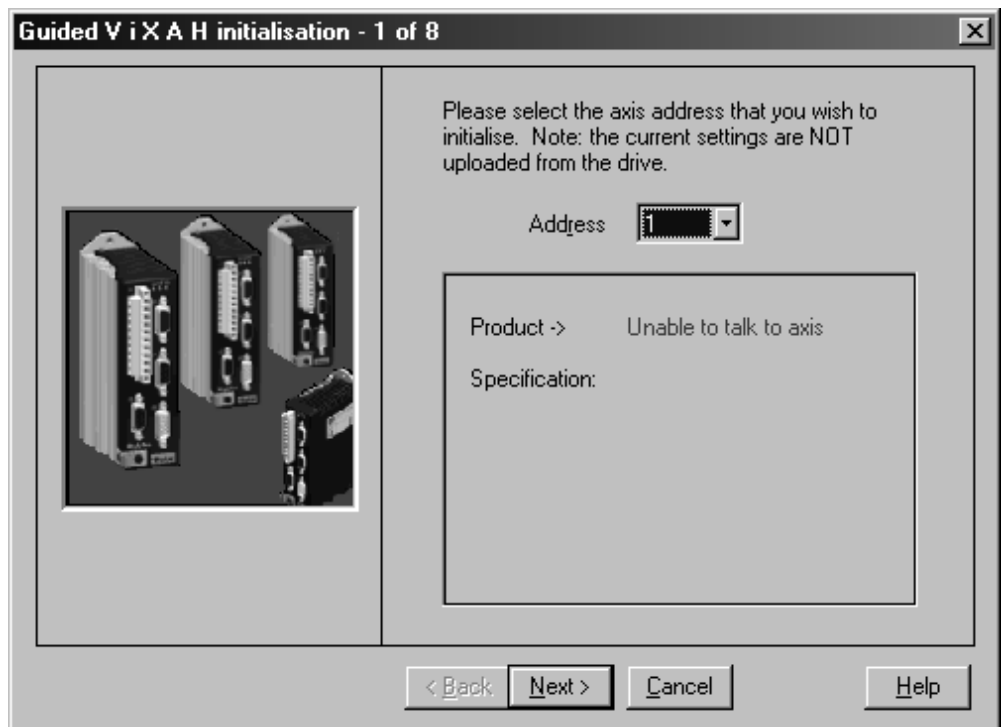

Click 'Next>'.

From the drop-down menu select your motor type or perform a custom set-up.

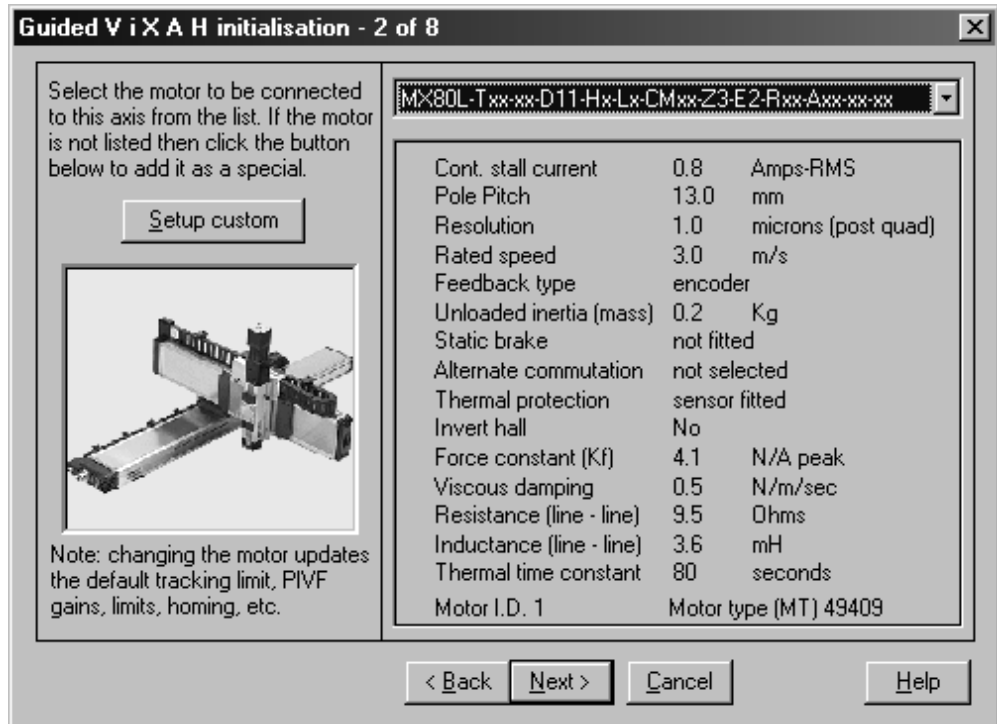

Click 'Next>'.

Select the operating mode of the drive and the direction of rotation required for a rotary motor.

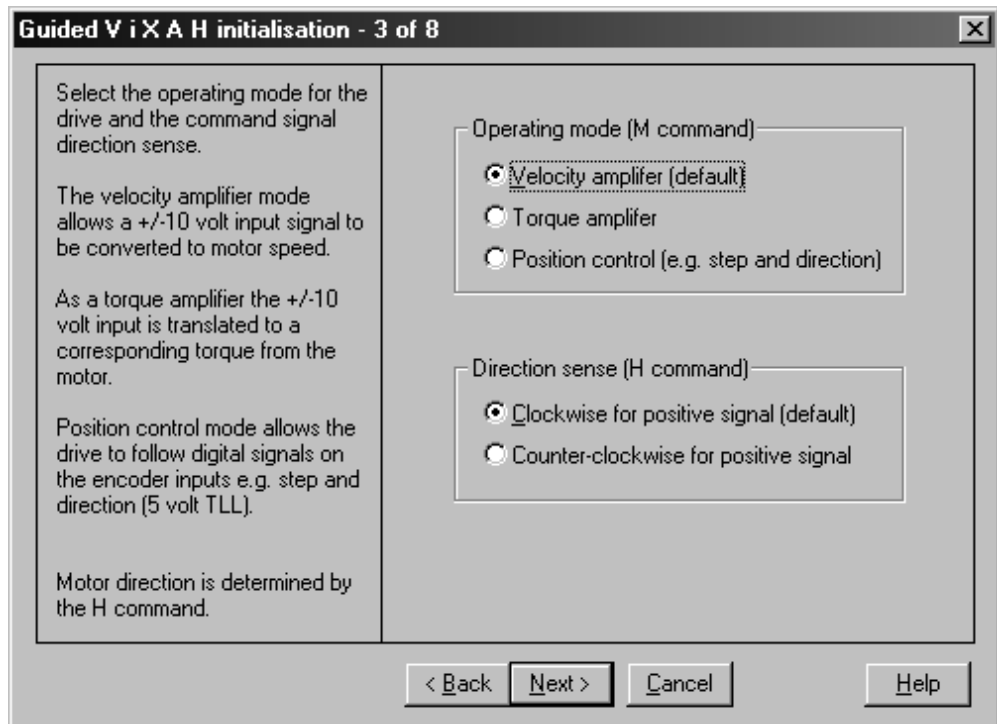

Click 'Next>'.

Use this screen to adjust the value of the Peak Current ratio (PC). For a pre-defined motor type use the default value displayed.

Keep the Current Clamp (CL) value as 100%.

Click 'Next>'.

**Guided V i X A H initialisation - 4 of 8**

Tracking limit (TL) determines when the axis sees a motor stall and is normally set to the same value as the motor resolution (to prevent nuisance faults). Only applicable for position mode.

Peak current ratio (PC) is used to match drive peak output to that of the motor. It is important to set this correctly to prevent excessive motor current.

Current clamp (CL) limits drive peak output current. This setting over-rides the value of PC and so can limit the output current to a value less than the motor normally requires. CL = 100% means full peak output.

Tracking limit (TL)

$\% \text{ Peak current ratio} = \frac{\text{desired maximum drive current}}{\text{motor nominal current (MC)}}$

$\% \text{ Peak current ratio (PC)}$

$\% \text{ Drive current clamp (CL)}$

< Back   Next >   Cancel   Help

This screen allows adjustment of the drive's gain parameters.

For drive testing purposes keep the default values suggested by the motor type.

Click 'Next>'.

**Guided V i X A H initialisation - 5 of 8**

These gain parameters can be adjusted to improve the dynamic response of the system.

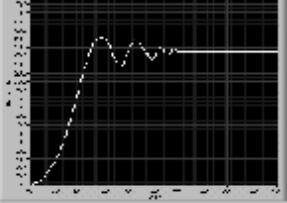

The operating mode determines which of the servo gains can or need to be adjusted.

Feedforward (GF)

Integral (GI)

Proportional (GP)

Velocity (GV)

Filter time (FT)

< Back   Next >   Cancel   Help

Use this screen to configure the brake input to match the output generating the brake signal.

The screen also allows selection of the type of simulated encoder output or input required.

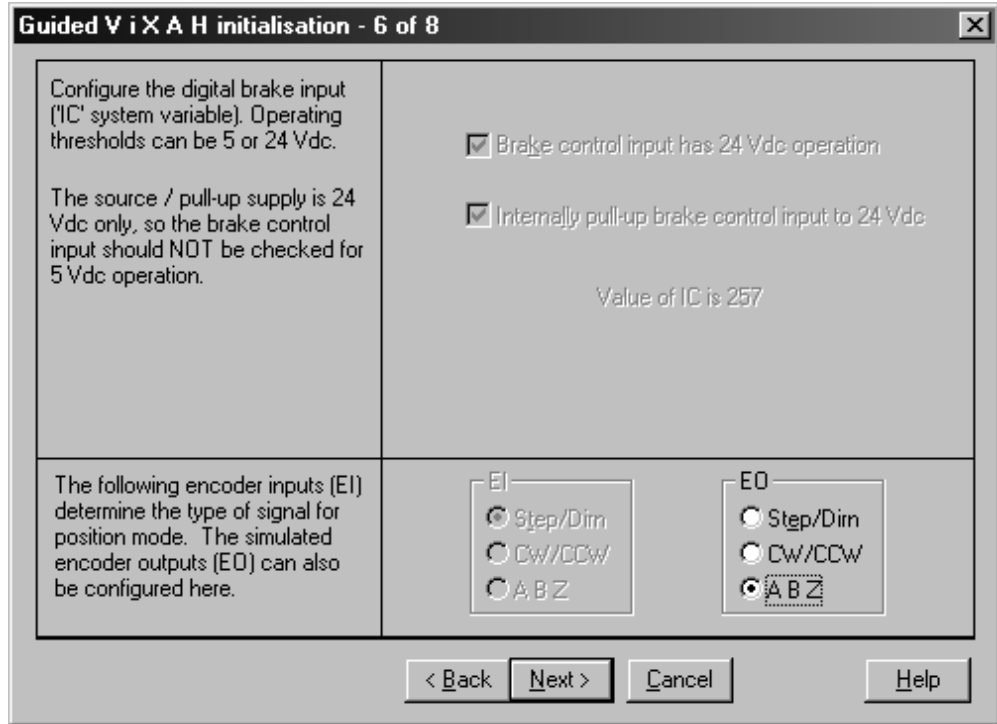

Click 'Next>'.

- High logic level 24V source (IC = 256) [upper box ticked lower blank] (default)
- High logic level 24V sink (IC = 257) [upper and lower boxes ticked]
- Low logic level 5V source (IC = 0) [no boxes ticked]

Note: Upper box blank and lower box ticked is a non-valid configuration, see WARNING below.

**WARNING – risk of equipment damage**

**Do not attempt to drive the brake input with a low logic level (5V) sink output. Internally, the drive pull-up voltage is 24V.**

The general configuration screen allows adjustment of motor brake settings, communication settings, analogue input control and defines what is monitored by the monitor output.

The state of system variable ES can also be set via this screen.

Click 'Next>'.

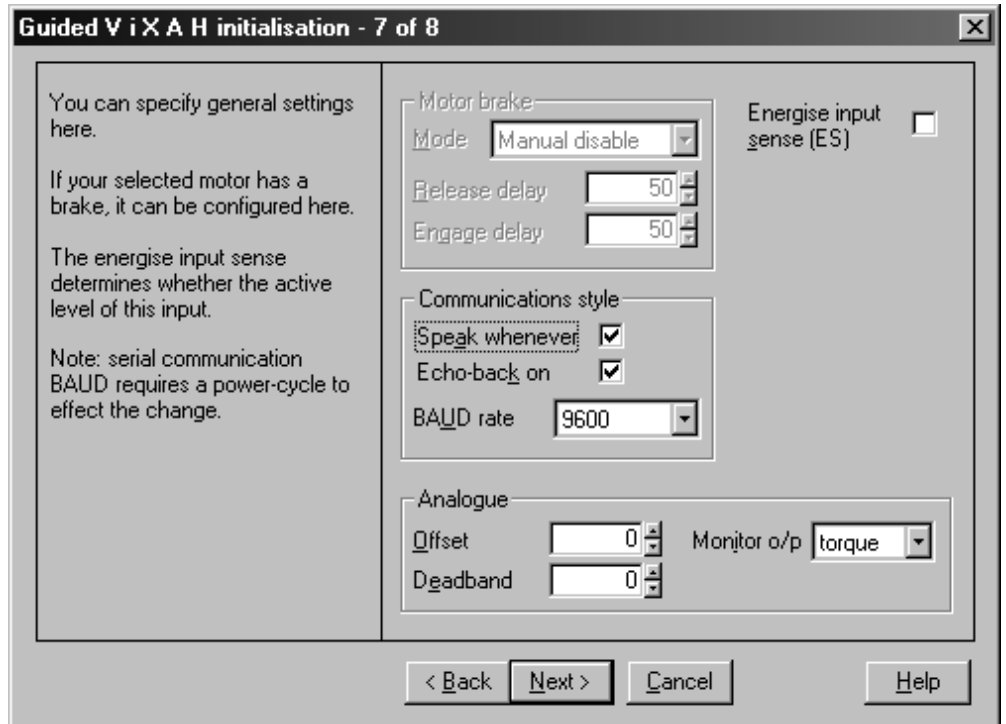

With ES ticked (ES=1) the drive is energised without any connection being made between X4 pin 11 and X4 pin 3 or 4.

This screen indicates the completion of the guided servo setup.

Clicking on the 'Create a setup program' creates a configuration file which may be saved to disk on the controlling PC. Clickin on 'Download immediately' downloads the configuration file to the drive.

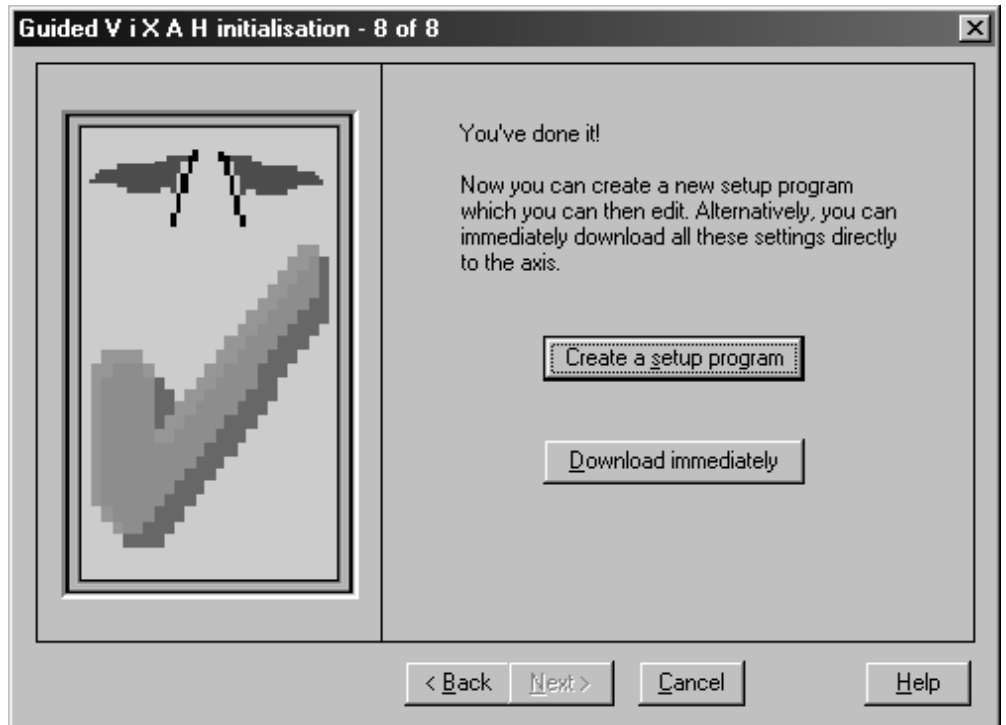

**NOTE**

**ANY CHANGES TO THE MOTOR COMMAND MUST BE FOLLOWED BY A SAVE (SV) AND RESET (Z) OR CYCLING POWER TO THE DRIVE.**

## Servo Setup

This facility gives easy access to setting system variables in a more direct manner than Guided Servo Setup. Figure 5-5 shows a sample screen.

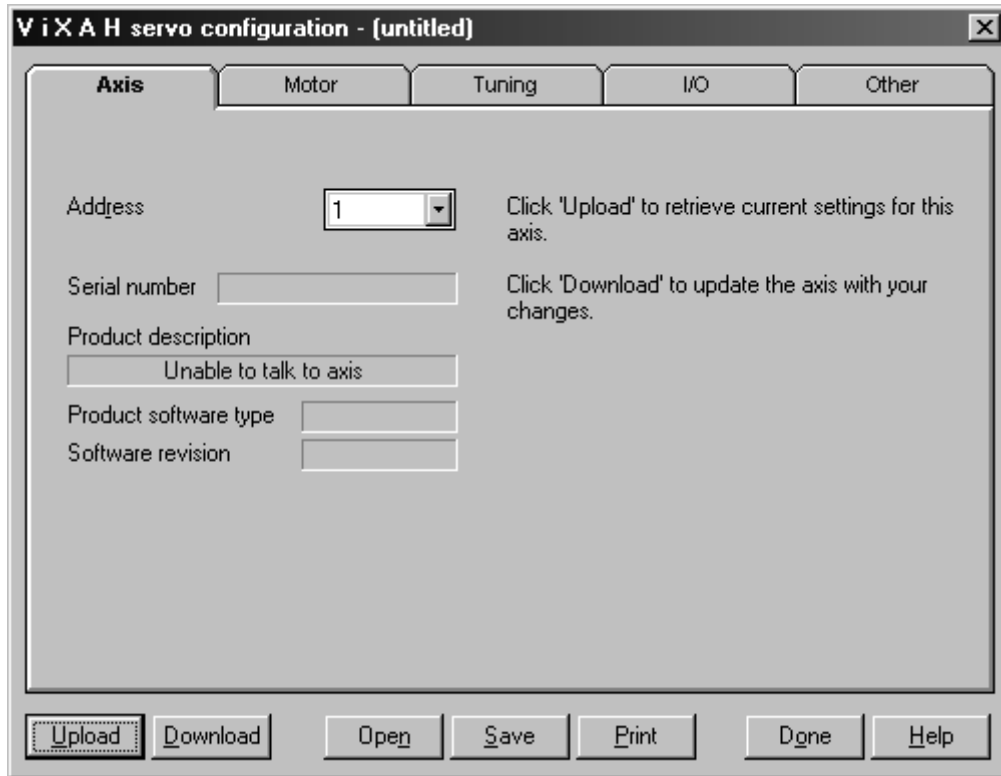

**Figure 5-5. Other Tab of Servo Setup**

The buttons displayed along the base of this screen can be used as follows:

**Upload** retrieves the current settings for the selected axis

**Download** updates the current axis with your latest changes

**Open** opens a stored .cfg file

**Save** save the file to disk as a .cfg file

**Print** prints the value of all the settings of all the tabs

**Done** closes the set-up window

**Help** accesses the help file



## Status

The Utilities menu axis Status provides a convenient method of examining the double word status bits. The tool gives access to the status of User Faults, Status bits and Drive Faults using a series of tabs, as shown in Figure 5-6.

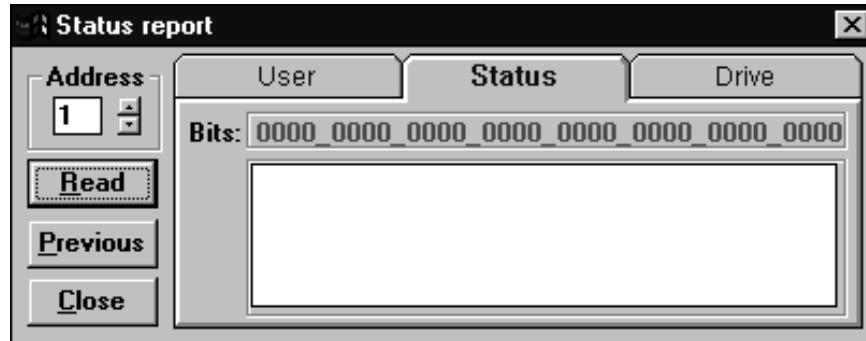

**Figure 5-6. Status Reporting**

The Status Report can be permanently displayed during program development or testing to monitor the operation of the drive. The double word status bits are decoded and displayed as text messages within the Status Report window, as shown in Figure 5-7. This eliminates manual decoding errors and gives an immediate update of the drive's status.

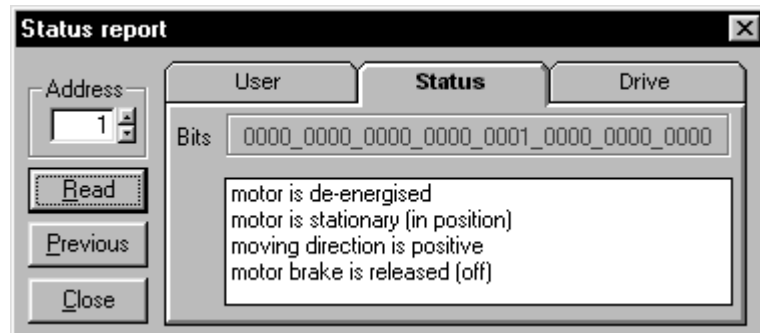

**Figure 5-7. Reporting Status of Drive**

### **Read**

The Read button is used to update all of the Status Reports and is a useful aid when debugging an application.

### **Previous**

Selecting Previous allows the previous status to be re-displayed - useful for comparing the results of programming actions. The Previous reading is only stored to a depth of one, that is, you cannot trace the history of status bits by continually selecting the button.

### **Close**

Selecting Close will exit the Status Report window.

## Help

EASI-TOOLS has extensive on-line help facilities, which allows you to search for help on a particular topic either within the main contents or by entering a topic string. All the commands listed within this user guide are available on-line by selecting Controller Commands from the Help menu.

---

## 6. Command Reference

### Command Description

Each command has a simple 1 to 7 character name usually an abbreviation of its full descriptive title. Listed commands are in alphabetic order with any non-alphabetic symbols appearing last.

Each individual description will include a one-line header giving the abbreviated name followed by its full name. The following lines give the command syntax, units of measurement, range of values, any default value and a reference to other related commands. Where commands contain a list of parameters, a simple layout displays only the syntax of the command.

**Every command requires an address.** Where several drives need to respond to a common set of global commands, prefix each command with the address 0. To prevent spurious feedback any report or read command using address 0 will be ignored. Note a drive will ignore a command missing an address prefix.

Where commands (such as R, and W) include a system variable, it is treated as a command parameter. System variables store internal drive values and settings. Each variable is capable of being read and tested, and some may be written to, but they are all dedicated for a particular use by the system.

### Command Syntax

Generally, a command's syntax consists of an address 'a' followed by the command name. Parenthesis containing the commands' parameters or simply the range parameter 'n' follows this. Within the parenthesis form of command, a comma separates each parameter and italics indicate any optional parameters.

Commands not requiring any parameter string have the syntax shown in Figure 6-1.

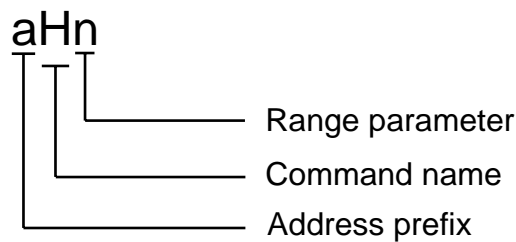
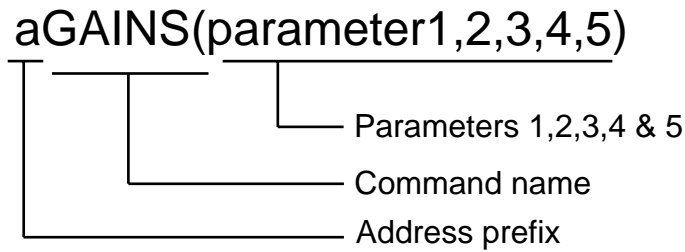

Figure 6-1. Simple Command Syntax

A multi-parameter command can take the form shown in Figure 6-2.



Note: optional parameters are displayed in italics

**Figure 6-2. Parameter Commands**

### Attention

- [1] Terminate all commands with a carriage return. A space is not valid.
- [2] A command must not contain any space characters.
- [3] All commands are device specific, that is, they always need an address.
- [4] For reasons of clarity, program examples appear as if being downloaded via Easi-V, that is they contain comments and line feeds etc.

## Command Properties

Each command has a particular set of properties that govern the way the command can be used.

Commands can have the following properties:

- Immediate only
- Immediate or buffered
- Saved by SV
- Not saved by SV

**Immediate Only**

Immediate only commands are:

K, R(UF), R(DF) and R(ST)

The controller acts upon these commands as soon as they are received.

**Immediate or Buffered**

Immediate or buffered commands are immediate unless command execution is being delayed, in which case the command is buffered. When command execution is being delayed whilst waiting to finish a previous command, interrogation commands can be sent and get executed immediately. Consequently, the report of such commands as 1R(ST), 1R(UF) etc. is correct. However, if a buffered type of command is sent the buffered command just sent and any other interrogation commands get buffered and will not report back until the current function is finished. In this situation 'Immediate only' commands can be executed.

**Saved by SV**

A command that has the property of being 'saved by SV' means data associated with that command is capable of being stored in non-volatile memory. The saved value will become the default value on power-up or following a Z command.

**Not Saved by SV**

If the command does not change data, such as K or Z, the commands' properties are listed as 'not saved by SV'.

**Automatic Checking of Valid Commands and Parameters**

All commands and parameters are checked for syntax and parameter limits at data entry.

For example:

**1BRAKE(2)**

Upon entry, this will cause a \*E, *value is out of the valid range* type error report.

---

## BRAKE Brake configuration

---

**Syntax****aBRAKE***n*(*mode*,*RD*,*ED*)

---

**Description** *n* is used to release a brake and to cancel any previously selected automatic mode.

**mode** selects the way the brake is used

- A** automatic holding brake mode
- D** automatic dynamic brake mode
- E** external input used for brake (AE variant only)
- M** brake modes disabled (default)

**RD** is the time in milliseconds for the brake to release **after** the drive has energised. Range is 0 to 5000 milliseconds (default 50ms).

**ED** is the time in milliseconds for the brake to engage **before** the drive de-energises. Range is 0 to 5000 milliseconds (default 50ms).

**Properties** Immediate, saved by SV

**Note** This command configures the brake. Before you can execute a brake command, you must send the drive a valid motor command where the motor type has a brake fitted.

The brake input will only be active in mode E.

### WARNING

**In mode E, control of the motor brake is immediate with no delays. You must ensure this form of direct control is safe and appropriate for your application.**

---

# GAINS Gain configuration

---

**Syntax**
**aGAINS(GF,GI,GP,GV,FT)**

---

**Description** Issuing a GAINS command with no parameters, produces a verbose list of all current gains. Parameters may be set up all together in one command. Alternatively, gains may be individually set/reported by using the read and write variable commands.

GP : Gain Proportional  
 GV : Gain Velocity feedback  
 GF : Gain Feedforward  
 GI : Gain Integral action  
 FT : Filter time constant

For ranges see the system variables list.

**Properties** Immediate, saved by SV

**Notes** The only gains used in calculating the positioning control are those appropriate to the particular mode of operation

	<b>MODE</b>		
	<b>Torque</b>	<b>Velocity</b>	<b>Position</b>
<b>GAIN TYPES</b>			
<b>Feedforward</b>	No	Yes	Yes
<b>Intergral action</b>	No	No	Yes
<b>Proportional</b>	No	No	Yes
<b>Velocity</b>	No	Yes	Yes
<b>Filter time</b>	No	Yes	Yes

You can write to all gains types, any irrelevant parameters will be ignored.

Individual gain variables may include decimal values, such as 1.2.

---

## H Change direction

Syntax	Units	Range of 'n'	Default	See also
aHn	-	+ or -	+	STATUS

**Description** The **H** command changes the direction of motion according to a positive demand signal. A blank value following the H command will be reported as an error.

**Properties** Immediate, saved by SV

**Note** The drive must be de-energised for the H command to be executed. If the command is issued whilst the drive is energised, an error message will be generated and the command will be ignored.

Specifying H+ sets the direction to clockwise for a positive analogue input voltage and H- produces counter clockwise rotation for a positive input voltage.

The direction assigned to H can be reported using the STATUS command.

---



# K Kill

Syntax	Units	Range of 'n'	Default	See also
aK	-	-	-	OFF, SETUPFB

**Description** The KILL command will perform the following functions:

- Abort a SETUPFB command.
- Execute an OFF command
- Set the fault output

*This command is used as an immediate stop and does not attempt to control deceleration.*

**Properties** Immediate, not saved by SV

**Note** Aborting SETUPFB will prevent an energise state from happening and will flag the motor as being undefined

Motion may only be commanded once the energise input has been cycled following a **KILL** command.

*Care must be taken that the demand is removed before re-energising as the drive will respond immediately to the demand.*

A drive enable error will be indicated which, together with the fault output, will be reset on a successful energise state.

---

# M Mode

Syntax	Units	Range of 'n'	Default	See also
aMn	-	see below	-	-

**Description** The mode command sets up the mode of operation of the drive.

The values of n are:

- P – base servo position mode (step and direction input)
- T – base servo torque mode (analogue torque input)
- V – base servo velocity mode (analogue velocity input)

**Properties** Immediate, saved by SV

**Example 1** The code below sets up for torque demand.

```
3MT ;mode torque
```

To check the current mode, type..... **3M**

The response will be ..... *\*MT*

**Note** The drive must be de-energised for the **M** command to be executed. If the command is issued whilst the drive is energised, an error message will be generated and the command will be ignored.

**When re-energising the drive will respond immediately to the new demand.**

See GAINS command for gain parameters relevant to the particular mode.

---

# MOTOR Motor Settings

---

<b>Syntax</b>	<b>aMOTOR(Type,Current,Resolution,Max_vel,Thermal_const,Resistance,Inductance,KT)</b>
---------------	---

---

**Description** This command describes the characteristics of the motor being used to the rest of the drive. The parameters used are:

**Type** – 0 to 65535 number code, which includes pole count, feedback type, brake and any other particular requirements (refer to EASI-V).

**Current** – RMS continuous stall current (0.1 to 14.4 A in 0.1 A increments). Default setting depends upon motor type. RFS default setting is 0.1 A.

**Resolution** – Rotary servo 2000, 4000, 4096, 8000, 20000 in steps/rev (post-quad) Linear servo 2,000 to 4,200,000 in steps per pole pitch

**Max\_vel** 1 to 12,000 rpm

**Thermal\_const** – Thermal time constant of the motor 0 to 65000 seconds

**Resistance** – Winding resistance in Ohms\*

**Inductance** – Winding inductance in mH\*

**KT** – Torque constant of the motor (Nm/A)

Note: Thermal time constant – is the time in seconds for the motor to reach two-thirds of its rated temperature while operating at its continuous current rating

\*Measured line-to-line across the motor terminals.

The command sets all of the motor parameters and then calculates the optimum settings for the digital torque amplifier.

If there is no HV present when the motor command is issued, the HV is assumed to be 80V, and this figure is used for the calculation of the digital torque amplifier optimum settings. When operating the drive at a voltage other than 80V DC, make sure the HV is present when issuing the motor command. Otherwise, the settings of the digital torque amplifier will not be optimised.

**IT IS IMPORTANT TO RE-ISSUE THE MOTOR COMMAND IF YOU CHANGE THE HV.**

**ANY CHANGES TO THE MOTOR COMMAND MUST BE FOLLOWED BY A SAVE (SV) AND RESET (Z) OR CYCLING POWER TO THE DRIVE.**

**Properties** Immediate, saved by SV

**Note** [1] If the thermal time constant is set to zero, the I<sup>2</sup>t protection for the motor is disabled.

[2] **The motor command can take up to 10 seconds to finish execution.**

[3] The drive will not be allowed to energise without a valid motor command being executed.

## R Report system parameter

Syntax	Units	Range of 'n'	Default	See also
aR(system_variable)	-	-	-	W, R

**Description** The R command allows the user to read the specified **system variable**.

**Properties** Immediate, not saved by SV

**Example**

```
2W(TL,4000) ;set variable TL (Tracking Limit) to be 4000
2R(TL) ;report the current value of variable TL
The response will be ..... *4000
```

**Note** See table of system variables.

# RFS

## Return to factory settings

Syntax	Units	Range of 'n'	Default	See also
aRFS	-	-	-	SV

**Description** Issuing an **RFS** command initialises the drive to factory default settings. The drive must be de-energised (OFF) for the **RFS** command to be executed.

**Properties** Immediate, saved by SV

**Note** The address is set to axis 1 after performing an RFS command.

The command takes effect immediately but a SV command must be executed to make the reset values permanent for future power cycles.

## SETUPFB SETUP motor FeedBack

Syntax	Units	Range of 'n'	Default	See also
aSETUPFB	-	-	-	K

**Description** For a correctly wired Parker motor, this command is not required. However, when commissioning problems occur with a motor/drive system, the SETUPFB command can be used to troubleshoot motor wiring problems in encoder and resolver units and to temporarily compensate for these errors.

The command reports wiring errors to the user:

**Correct these errors in hardware before shipping any system.**

If the command cannot correct an error it will display a message indicating the nature of the problem, followed by a FAIL message.

### CAUTION

**DO NOT COUPLE ANY MACHINERY TO THE MOTOR SHAFT WHILE RUNNING THIS COMMAND AS SHAFT MOVEMENT WILL OCCUR.**

Correct your wiring, as this will prevent future problems if you replace your motor or drive, since the software correction cannot be uploaded from a drive. Note, if you do use SETUPFB to permanently correct errors in non-standard motor/drive systems, you will need to run the MOTOR command followed by SETUPFB on every system.

**Properties** Immediate, saved by SV

**Example** 1SETUPFB ;commission a new motor attached to the drive

**Note** You can abort this command using the KILL command. Under these circumstances, energising cannot take place until SETUPFB is correctly executed .

# STATUS STATUS of Drive

Syntax	Units	Range of 'n'	Default	See also
aSTATUS	-	-	-	

**Description** Use this command to check the state of a drive. It is intended for set-up purposes rather than for use when a program is running.

**Properties** Immediate or buffered, can't be used in a labelled block, not saved by SV

**Example** `1STATUS` ;checking the configuration and state of a drive

```

1STATUS
*ViX500AH-Servo Copyright 2002 Parker-Hannifin
*Firmware: REV 2.2D Dec 03 2002 17:11:23 Map No: 114
*Serial number: ..541935.00.1.4. -ViX500xx
*Control card revision 2 Servo drive
*Power card revision 3 Servo power stage E500
*Motor type undefined
*
*FPGA_ID (read)..... 0 FPGA_ID (file)..... 0
*
*MOTOR TYPE ..... 0 RESOLUTION ..... 42000
*CONT. STALL CURRENT ... 0.1 Amps POLES ..... 2
*PEAK CURRENT (PC)..... 300 % TRACKING LIMIT (TL).. 420
*INDEX POSITION (IX).... 10500
*
*MOTOR SUPPLY..... 81 V AUX SUPPLY..... 5.1 V
*I/O SUPPLY..... 23 V I/O CONFIGURATION... 256
*INTERNAL TEMPERATURE... 28 C HEATSINK TEMPERATURE. 25 C
*
*ANALOGUE VELOCITY CONTROL (MV)
*CURRENT POSITION (PA)... 0.00 DIRECTION OF H (CW.... +ve
*ACCELERATION (AA)..... 10.0 ERROR (PE).... 0.0
*POSITION MODULUS (PM).. 0
*
*AXIS: READY
*DRIVE FAULTS (DF): 1010_0010_1000_0000_0000_0000_0000_0000
*DRIVE STATUS (ST): 0000_0000_0100_0000_0001_0000_0000_0000
*USER FAULTS (UF): 0000_0000_0000_0000_0000_0100_0000_0000

```

Note: Motor type has not been defined.

## SV Save configuration

---

Syntax	Units	Range of 'n'	Default	See also
aSV	-	-	-	Z

---

**Description** When the **SV** command is issued, the current drive system variables and configuration are stored in non volatile memory. Following a reset or power-cycle the settings held in the non-volatile memory will be restored into the drive.

Wait 1-2 seconds before sending any other command following an SV.

**Properties** Immediate

**Example**

<b>1RFS</b>	;return drive to factory settings
<b>1MP</b>	;set drive to position mode (step/direction control)
<b>1SV</b>	;save current settings
<b>1Z</b>	;reset drive
<b>1M</b>	;report current drive mode
<i>*MP</i>	

**Note** This command will not operate whilst the motor is being commanded to move.

---



## W Write system variable

---

<b>Syntax</b>	<b>aW(system_variable,value)</b>
---------------	----------------------------------

---

**Description** The **W** command allows you to set a specified **system variable** to a particular **value**.  
Refer to the table of system variables for more information.

**Properties** Immediate not saved by SV

**Example** Set system variable TL (Tracking Limit) to 4000      **2W(TL,4000)**  
Report the current value of system variable TL      **2R(TL)**  
The controller responds with..... \*4000

**Note** The drive will need to be de-energised before certain system variables can be written to.

See also R command.

See table of allowable variables for individual parameter details.

---

## Z Reset

---

<b>Syntax</b>	<b>Units</b>	<b>Range of 'n'</b>	<b>Default</b>	<b>See also</b>
<b>aZ</b>	-	-	-	<b>SV</b>

---

**Description** The **Z** command resets the drive. This is similar to power cycling the drive.  
Wait 1-2 seconds before sending any other command following a Z.  
Following the issue of the Z command, any configuration which has been made but not saved, with the SV command, will be lost.

**Properties** Immediate, not saved by SV

**Example** To reset all drives, type..... **0Z**

---

## System Variables

Var	Name	R	W	Range/default value
AB	Analogue Deadband	Y	Y	0 to +255, default = 0
AI	Analogue Input	Y	N	-2047 to +2047
AM	Analogue Monitor Mode	Y	Y	0 = torque monitor (default) 1 = velocity monitor 2 = outputs a triangular waveform -10V to +10V amplitude, with a 1 second period
AO	Analogue Offset	Y	Y	-2047 to +2047, default = 0
BR	BAUD rate	Y	Y	9600 (default) or 19200 bits per second
CL	Current Clamp	Y	Y	1 to 100% (default) of peak drive current
DF	Drive Fault status	Y	N	See reporting of drive faults DF1,2,3 & 4
EI	Encoder Input	Y	Y	0=step/dir (default), 1=cw/ccw, 2=quad ABZ, de-energise drive to change
EO	Encoder signal Output	Y	Y	0=step/dir, 1=cw/ccw, 2=quad ABZ (default), de-energise drive to change
ES	Energise Sense	Y	Y	Sets the sense of the external energise/energise_bar signal 0=low signal to energise (default) 1=high signal to energise
EX	Comms. Response Style & Echo Control & Physical Interface (RS232)	Y	Y	0= speak when spoken to, echo off, RS232 1= speak whenever, echo off, RS232 2= speak when spoken to, echo on, RS232 3= speak whenever, echo on, RS232 (default)
FT	Filter Time constant	Y	Y	0 to 255 used to filter high gain systems, measured in arbitrary units, default = 0
GF	Feedforward Gain (tracking)	Y	Y	0 to 1023 default = 5

Var	Name	R	W	Range/default value
GI	Integrator Gain (steady state)	Y	Y	0 to 1023 default depends on motor type
GP	Proportional Gain (stiffness)	Y	Y	0 to 1023 default depends on motor type
GV	Velocity feedback Gain (damping)	Y	Y	0 to 1023 default = 5
IC	Input/Output Configuration	Y	Y	Input pull-up/down, output source/sink configuration 0, 256 (default) or 257, for brake input only
IM	Integral Mode	Y	Y	0=continuous (default)
IW	Integral Window	Y	Y	default 50
IX	Index Pulse	Y	Y	0 to 1023, default=250, motor definition dependent
PA	Position Actual	Y	N*	-2,147,483,648 to 0 to 2,147,483,647, default = 0
PC	Peak Current	Y	Y	Sets maximum drive output value=scaling factor 100-400% of MC, default=300%
PE	Position Error	Y	N	+/- 32767
PF	Position Following	Y	Y	-2,147,483,648 to 0 to 2,147,483,647, default = 0
RV	ReVision of software	Y	N	x.yy major.minor
SN	Serial number	Y	N	Drive serial number
ST	Status of indexing	Y	N	See Reporting the Status of Variables ST1,2,3 & 4
TL	Tracking Limit	Y	Y	0-65535, defaults to Motor Resolution or Motor Resolution/100 if >65535
UF	User program Fault status	Y	N	See Reporting of user faults UF1,2,3 & 4

\*Can be set to 0 only.

## Drive Faults

Bit Number	Stop	Type	DF Information
1			Composite fault (anything that causes a drive fault)
2	K	T	+/-15V supply rail
3	K	R	Motor HV under-voltage trip point reached
4	K	R	Motor HV over-voltage trip point reached
5	C	R	V I/O under-voltage trip point reached
6	C	R	V I/O over-voltage trip point reached
7	K	T	Encoder/Auxiliary 5V under voltage trip
8	K	T	Impending power loss (24V – logic supply)
9	K	T	Commutation Fault
10	-	-	N/A
11	C	R	Motor over temperature
12	C	R	Ambient over temperature
13	C	R	Drive over temperature
14	K	T	Incompatible firmware version
15	K	T	Unrecognised power stage
16	K	T	Controller diagnostic failure
17	K	R	Output stage over current
18	C	R	Output driver over current
19	C	R	Tracking limit exceeded while in motion is a latched fault
20	K	R	Velocity exceeded (unstable gains/motor spin-off)
21	C	R	Energise input not set – check energise input and state of ES variable
22-24			Reserved
25	K	T	Watchdog 1
26	K	T	Watchdog 2
27	K	T	Watchdog 3

Key: C: Performs controlled stop  
 K: Performs motion kill – quick stop. Possible instant de-energise depending on fault source  
 R: Recoverable without power cycle  
 T: Terminal (requires power cycle or repair before drive will energise/operate again)

## Status Bits

Bit Number	Status Information
9	Motor energised
10	Motor undefined, use MOTOR command
16	Duty cycle too high, excessive motor current ( $I^2t$ )
23	Tracking limit is greater than max. allowed position error
24	Last SETUPFB command failed
25	In motion, 0 for positive motion, 1 for negative motion
26	Brake applied, goes to a 1 if the brake is engaged

## User Faults

Bit Number	UF Information
1	Value is out of range
2	Incorrect command syntax, command has wrong format
8	Drive de-energised
16	Transmit buffer overflow*
19	Drive not ready
22	Save/restore error
23	Command not supported by this product
26	Cannot execute motion as the brake is engaged
27 to 32	Reserved

\*sends an ASCII 'bell' character to indicate a buffer overflow condition.

**Command List**

<b>Command</b>	<b>Description</b>
<b>BRAKE</b>	Brake configuration
<b>GAINS</b>	Gains configuration
<b>H</b>	Change direction
<b>K</b>	Kill
<b>M</b>	Mode
<b>MOTOR</b>	Motor settings
<b>R</b>	Report system parameter
<b>RFS</b>	Return to factory settings
<b>SETUPFB</b>	Setup motor feedback
<b>STATUS</b>	Report status of drive
<b>SV</b>	Save configuration
<b>W</b>	Write system variable
<b>Z</b>	Reset

## 7. ViX Maintenance and Troubleshooting

---

### Maintenance

ViX drive systems do not require any routine maintenance, but occasional checking of the following points is recommended.

### Motor inspection

Periodically check the motor to ensure that the mounting bolts and couplings are tight. Check that the motor cables are not being damaged by moving parts and are not being pulled or forced into tight bends during machine operation. Check all cable connectors and particularly the safety earth connection.

### Drive inspection

Check that the drives are clear of loose material and that there is adequate clearance to allow a free flow of air through the ventilation slots. Check that drive fixings are tight and that the motor screen connection is secure.

---

### Troubleshooting

**IMPORTANT NOTE** - ensure that power is turned off before any connections are removed or changed. Removing a drive with power applied can turn a recoverable fault situation into a major problem.

**WARNING – Risk of damage and/or personal injury**

The ViX drives described in this user guide contain no user-serviceable parts. Attempting to open the case of any unit, or to replace any internal component, may result in damage to the unit and/or personal injury. This may also void the warranty.

## Communication Problems

When attempting a Connect from the Terminal menu, if the connection fails with the following error message:

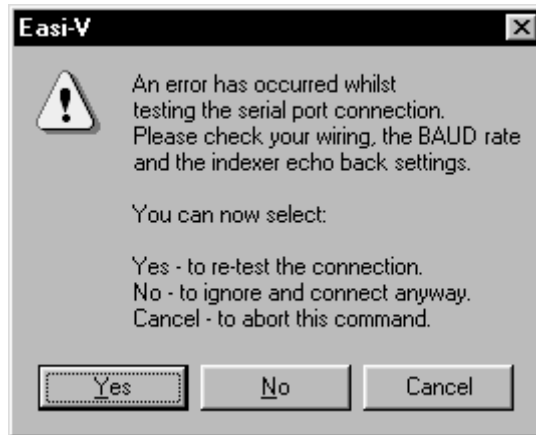

**Figure 7-1. Communications Failure Error Message**

Check the following:

1. Ensure the serial port configuration is set correctly in EASI-V and you select the correct serial COM port.
2. An RS232 communications link can be loop tested by removing the communications D-type plug where it connects to the drive and placing a short between pins 4 and 5. In this condition, any command sent from the terminal window should be echoed back, confirming the integrity of the overall RS232 link. If this does not happen, check the RS232 lead connections and the PC serial port.

Note: wiring of the RS232 lead must conform to that recommended in the Hardware Installation section, a null modem cable cannot be used.



Drive LED Indicators

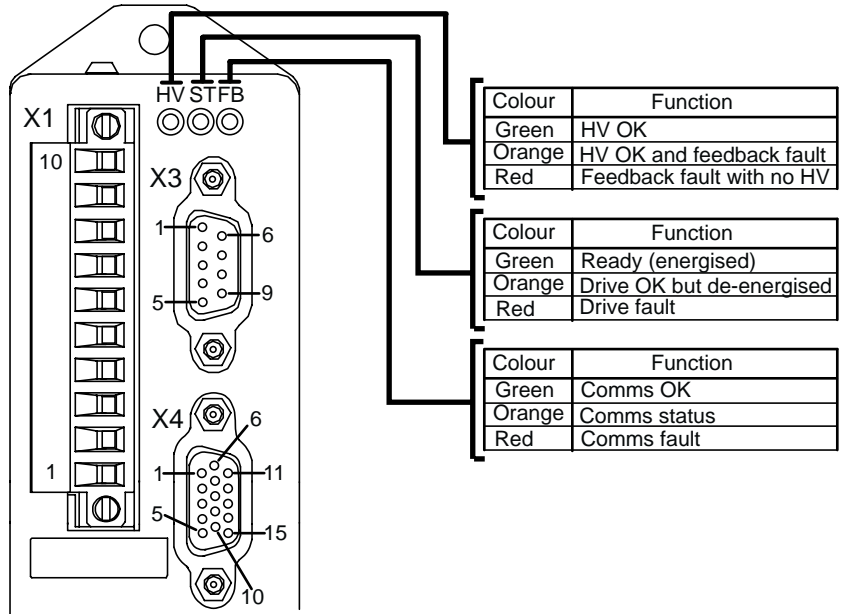

Figure 7-2. Drive LED Indicators

## Complete LED Diagnostics

An EASI-V version of this table is available for quick on-line viewing.

LED	Colour(s)	Flash rate	Functional description
HV	green	none	motor supply OK
HV	orange	none	motor supply under voltage (<16V)
HV	red	none	motor supply over voltage (>96V)
HV	off	-	no motor supply
ST	green	none	drive OK and motor is energised
ST	orange	none	drive OK but motor is de-energised
ST	red	none	drive fault (see DF report for more information)
ST	red/green	1 second	I <sup>2</sup> t duty cycle too high. Bit 16 of ST system variable set to 1.
ST	red/green	0.25 second	communications receive buffer over-flow. Only a power-cycle clears this condition.
ST	red/off	0.5 second	only on power-up following a flash upgrade. Indicates bad truncated FPGA file.
ST	red/off	1 second	only on power-up following a flash upgrade. Indicates a CRC error.
ST	off	-	no logic supply. All other LEDs will also be off.
FB	green	none	fieldbus communications OK. Operational state.
FB	green	1 second	fieldbus communications OK. Pre-operational state.
FB	red	none	fieldbus communications fault
FB	off	-	no fieldbus option

**Table 7-1. Status Bits Description (continued)**

### **Forcing a Hardware RFS**

Pin 2 of serial communications D-type connector X3 is for use as a hardware method of forcing a return to factory settings. It may be used when it is not possible to perform an OFF or RFS command.

To force a hardware RFS follow the procedure detailed below, note you will lose any program in memory and system variables will return to their default values:

1. Connect X3 pin 2 (MODE input) to X3 pin 3 (0V).
2. Cycle the power to the drive - on power-up, any program present in memory is cleared and ALL system variables are set to their initial factory default value.
3. Establish RS232 communications using Easi-V and type in 1SV and press [Enter] to store the changes.

## **Returning the System**

If a drive module is found to be faulty, you should contact your Parker Automation Technology Centre or the machinery manufacturer who supplied the product. Equipment for repair should NOT be returned directly to Parker without prior authorisation. Repairs will be carried out by Parker but will be processed via your supplier.

Parker may at their discretion authorise direct shipment to and from Poole, Offenburg or Rohnert Park, but only by prior arrangement with your supplier. Existing UK, European and USA customers who purchase equipment directly from Parker should contact Poole, Offenburg or Rohnert Park for further information (contact numbers are at the front of this User Guide).

---

## 8. Hardware Reference

### Drive Functional Specification – ViX250AH, ViX500AH

Parameter	Value
Maximum output current	ViX500: 5A RMS continuous 15A RMS peak (2 seconds max.)* ViX250: 2.5A RMS continuous 7.5A RMS peak (2 seconds max.)*
Maximum continuous power drawn from the supply	6.3A at 80V (500VA)
Motor HV supply input <b>(No reverse polarity protection, HV reversal WILL damage the drive)</b>	ViX500: 48 – 80V DC +5% -15% ViX250: 24 – 80V DC +5% -15%
Minimum PSU capacitance	ViX500: 6,600 $\mu$ F ViX250: 3,300 $\mu$ F
Controller supply input	24V DC +10% to –15%
Protection	Short circuit (phase-to-phase, phase-to-ground) Motor HV over and under voltage trip (HV over voltage 98V nominal) Drive over-temperature Motor over-temperature (motor dependent) 24V reverse polarity Commutation encoder fault Resolver fault
Temperature protection (motor protection depends upon the type used) see Note 1.	I <sup>2</sup> t circuit protects motor and drive from excessive dissipation
Motor current limit	Selectable by software
Motor inductance range	0.5 to 10 mH For lower inductance motors consult Digiplan
Fault output	NPN open-collector output, normally low, active high
Enable input	24V input with pull-up resistor (can be software set to be active high or active low)
LED status indicators (tri-colour)	HV/feedback fault Drive fault Comms. status

\* 2 sec rotating 0.4 sec stationary – see **Plots of I<sup>2</sup>t Against Drive Current**

**Table 8-1. Functional Specification**

Note 1 – See **Motor Overtemperature Sensor** in **Electrical Installation** section.

**Controller Specification**

<b>Parameter</b>	<b>Value</b>
Communication	
Data format	8 data bits, 1 start bit, 1 stop bit, no parity, optional echoback, Xon/Xoff supported
Baud rate	9600, or 19,200
Address setting range	1 -255 by software
RS232 connection	2 wire plus ground
Brake Input	
Input levels	Logic high 14 - 24V, logic low 0 - 4V
Input impedance	4K7
Fault Output	
Fault Output	open collector 30V max. 15mA sink

**Table 8-2. Controller Specification**

## Drive Environment Specification

Parameters	All drive types
Environment	Pollution degree 2
Operating temperature range	0 to 40°C ambient for natural convection cooling 40°C to 50°C with forced air cooling of minimum 0.5m/s entering the base of the drive (approximately 3.5m <sup>3</sup> /h or 2cfm airflow through the cabinet)
Storage temperature range	-20 to 70°C
Humidity	95% max. non-condensing
Cooling	Natural convection 0 to 40°C, forced air cooling 40 to 50°C
Housing	Plastic/Aluminium heatsink
Protection class	IP20
Weight	0.55kg

**Table 8-3. Drive Environment Specification**





## Appendix A

### Discrete Power Supply Recommendations

If the XL\_PSU is not being used individual ViX drives can be powered from transformer/bridge rectifier power supplies of the type shown in Figure A-1. This design suggests suitable component values for powering particular drive types, but can be adapted to power more than one drive provided component power ratings are not exceeded.

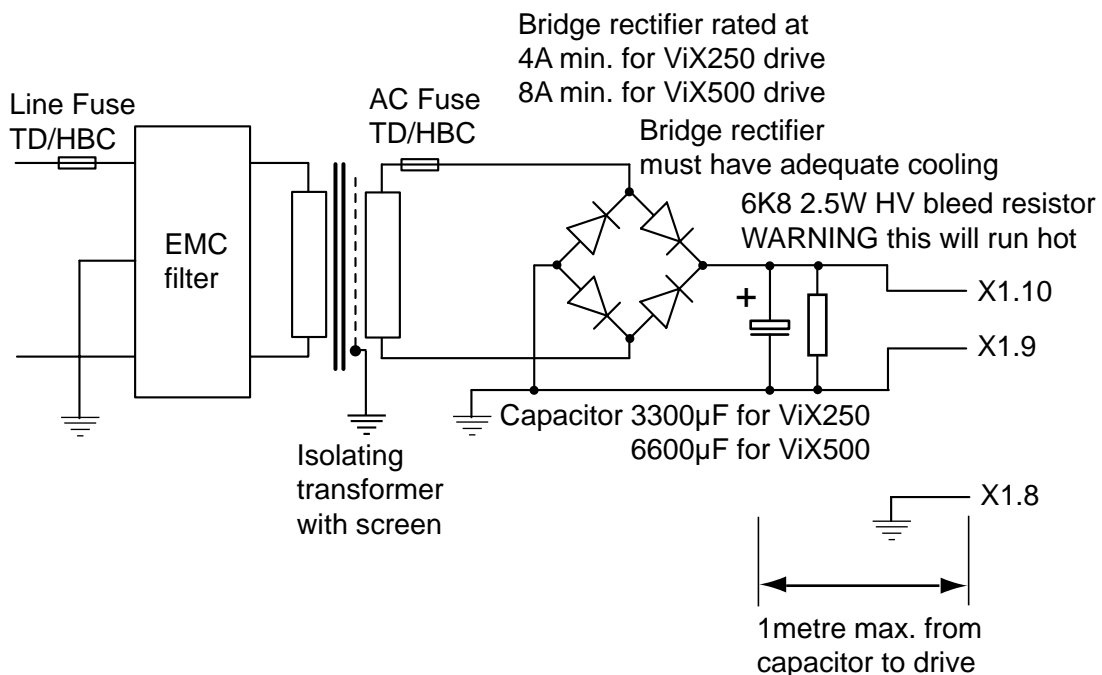

Figure A-1. Drive Power Supply

**Note:** The safety earth must be reliably earthed at X1.8. The –DC input should also be connected to earth at a convenient point.

### Supply Wiring

Use approved mains cable (at least 0.75mm<sup>2</sup>) for primary wiring and route it away from secondary and signal wiring. Power input wiring must have a voltage withstanding rating of at least 1000V AC RMS. Note this figure is a test voltage, not the rated working voltage of the cable. Power input and motor wiring must be kept separate from signal wiring and insulated from operator access.

Note: secondary wiring must have a current rating in excess of the AC fuse rating.

### Transformer Sizing for the DC Supply

A DC input is required by the drive, which can be generated by rectifying and smoothing the secondary voltage of a transformer. This is an unregulated supply so do not select a secondary voltage which generates a DC output greater than 80V.

The size of transformer required for a servo drive installation depends very much on the application and on the maximum shaft power delivered by individual motors.

It is worth noting that in a one-off or low volume application it is usually preferable to be slightly generous in sizing the transformer, rather than spend a great deal of engineering effort trying to calculate the minimum possible rating. In low-power systems the potential savings in transformer cost are not large, although size and weight may also be a consideration. In a higher volume application the same principles apply to the prototype installation, but measurements of the supply current drawn under working conditions will give a useful guide to the final specification required.

### **Fuses**

Fuses should be time delay, high breaking capacity and should be rated for the number of drives and expected in-rush current.

### **AC Fuse**

The secondary AC fuse is intended to protect power supply components and should have a value twice that of the bridge rectifier current rating.

### **Line Fuse**

Fit line fuses to protect the transformer primary and associated wiring. If you cannot identify the live wire, fuse both phase conductors. Calculate the fuse value using:

$$\frac{1.5 \times VA}{\text{supply volts}}$$
 in amps, but needs to be a minimum of 2A to cope with the in-rush current.

Fuse types should be anti-surge HBC (High Breaking Capacity).

Note: If the application requires a power dump, use a Digiplan power supply such as the PL1100.

### **CAUTION**

**Ensure that all power supply components are mounted away from operator access, as high voltages and hot surfaces are present in normal operation.**

---

## Appendix B – Encoder Phasing

### Encoder Phasing Diagrams for the ViX AH

Phasing is shown for clockwise rotation when the motor is viewed from the motor mounting flange.

Line voltage W-V is defined as X1 pin 2 with respect to X1 pin 3

Line voltage V-U is defined as X1 pin 3 with respect to X1 pin 4

Line voltage U-W is defined as X1 pin 4 with respect to X1 pin 2

Positive encoder rotation is defined as when incremental encoder channel A leads incremental encoder channel B by 90deg

There is only one index mark per mechanical revolution

Incremental channel A is “true” when X2 pin 8 is positive with respect to X2 pin 7

Incremental channel B is “true” when X2 pin 12 is positive with respect to X2 pin 11

Commutation channel A0 is at X2 pin 9

Commutation channel A1 is at X2 pin 13

Commutation channel A2 is at X2 pin 14

With respect to encoder GND

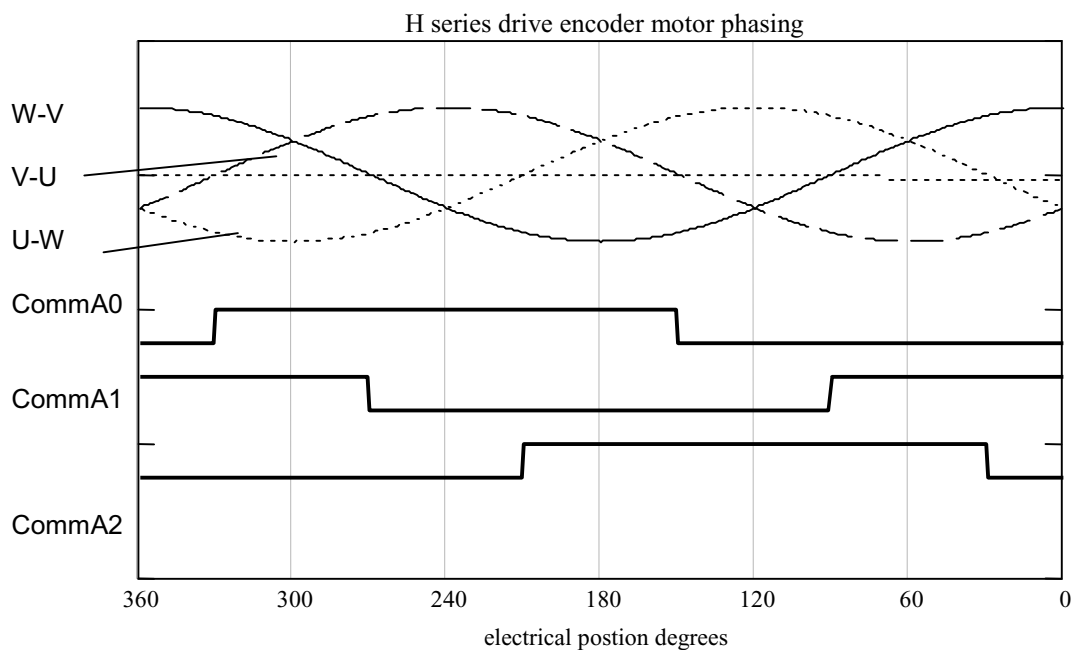



## Index

### 2

24V supply requirements, 11

### A

A to D converter, 40

AB, AI & AO system variables, 52

Absorber ferrite, 23

AI system variable, 40

AM system variable, 44, 52

ANA1 inputs, 40

Analogue input, 40

Analogue monitor output, 44

AO system variable, 40

### B

Baud rate changing, 36

Baud rate selection, 76

BE motor

cables, 19

BR system variable, 52

Brake

24V failure, 68

default setting, 67

drive fault, 68

enable, 67

input, 43

operation, 66

reset, 68

BRAKE command, 88

Brake control external, 67

Brake control wiring, 33

Brake fail safe, 32

Brake fuse, 33

Brake input specification, 112

Brake output, 32

Brake supply options, 33

Braking

automatic, 66

dynamic, 66

### C

Cabinet installation, 9

Cable part numbers, 19

Cable screening, 20

Capacitance of supply, 11

Clean earth, 9

Command

address requirements, 85

label & multi parameter syntax, 86

presentation, 85

reference, 85

simple syntax, 85

Command checking, 87

Command list, 104

Command properties, 86

Communication daisy chain, 46

Communication problems, 106

Communications specification, 112

Control of I<sup>2</sup>t parameters, 28

Controller specification, 112

Cooling, 113

Cooling requirements, 5

### D

DC supply amps, 11

DC supply capacitance, 11

DC supply volts, 11

Default directory, 70

DF bit order, 57

DF word, 57

Differential input, 40

Dimensions, 6

DIN rail mount, 7

Direct mode, 49

Disconnecting device, 9

Dissipation parameters, 27

Drive

cooling, 5

dissipation, 5

fault reporting, 58, 102

Drive fault

byte reporting, 58

Drive faults, 57

Drive inspection, 105

Drive types, 2

### E

Earth arrangements, 9

Earth connections, 11

Easi-V

communicating with drive, 75

help, 84

installation directory, 71

- menu overview, 73
- running, 71
- software file size, 69
- startup, 72
- status reporting, 83
- uninstall, 72
- ED operation, 66
- Edit menu, 73
- EI system variable, 53
- Electrostatic precautions, 9
- EMC
  - Installation, 17
- Encoder
  - input configuration, 53
  - output configuration, 53
- Encoder simulated I/O, 40
- Encoder specification, 34
- Energise input, 42
- Environment specification for drive, 113
- EO system variable, 53
- ES system variable, 53
- EX system variable, 53
- External brake control, 67
- F**
  - Fault output, 41
  - Fault output specification, 112
  - Fault status reporting, 57
  - Feedback connector screen bonding, 21
  - Feedforward gain, 54
  - Ferrite absorber
    - Curie temperature, 23
    - impedance, 23
    - part number, 23
    - size, 23
  - Ferrite absorber specification, 23
  - File menu, 73
  - Filter time constant, 54
  - Following encoder specification, 35
  - Forcing a hardware RFS, 109
  - FT system variable, 54
  - Function indicators, 2
  - Functional specification, 111
- G**
  - GF system variable, 54
  - Goto line number box, 73
  - GP system variable, 54
  - Guided servo setup, 77
  - GV system variable, 54
- H**
  - H change direction, 90
  - Hardware reference, 111
  - Help menu, 74
  - Housing material, 113
  - Humidity, 113
- I**
  - I<sup>2</sup>t operation, 27
  - I<sup>2</sup>t protection scheme, 27
  - IM system variable, 54
  - Immediate commands, 87
  - Immediate or buffered commands, 87
  - Immediate properties, 87
  - Inputs & outputs, 2
  - Installation, 9
  - Installation safety requirements, 9
  - Installation setup program, 70
  - Installation time for S/W, 70
  - Integrator gain, 54
  - IW system variable, 54
  - IX system variable, 54
- L**
  - LED flash codes, 108
  - Line fuse type, 116
  - Line fuse values, 116
  - LVD requirements, 9
- M**
  - Maintenance, 105
  - Maintenance & troubleshooting, 105
  - Mode
    - position, 92
    - torque, 92
    - velocity, 92
  - Motor
    - brake control, 33
    - cable lengths, 19
    - cables, 19
    - connections at drive, 20
    - connections at the drive, 20
    - default settings, 28
    - feedback connector wiring, 21
    - phase contactors, 23
    - power cable drive-end preparation, 20
    - safety earth connection, 28

- selection, 24
- system variables, 28
- wire size, 20

Motor inspection, 105

Motor mounting precautions, 8

MOTOR settings, 93

Motors

- optimum types, 24
- voltage rating, 28

## N

Not saved by SV, 87

## O

Overload of outputs, 28

Overtemperature switch connection, 35

## P

P clip part numbers, 20

P clip sizes, 20

PA system variable, 54

Parameter checking, 87

Parameter value checking, 87

PC requirements, 69

PC system variable, 55

PE system variable, 55

PF system variable, 55

PL1100

- product description, 16

Pollution degree, 113

Port configuration, 75

Power input cable size, 115

Power wiring precautions, 115

Product

- description, 1
- features, 2
- variants, 2

Properties

- immediate, 87
- save, 87

Properties of commands, 86

Proportional gain, 54

Protection circuits, 2

Protection class, 113

PSU discrete design, 115

## R

R report system parameter, 94

RD operation, 66

Reset to RS232 mode, 37

Returning the system, 110

RFS return to factory settings, 95

RJ45 connecting leads, 47

RJ45 patch cables, 47

RS232 cables, 38

RS232 connecting leads, 38

RS232 daisy chain, 44

RS232 mode forced reset, 37

RV system variable, 55

## S

Safety earth connections, 11

Save properties, 87

Saved by SV, 87

Search menu, 73

Serial communications configuration, 75

Serial link lead, 69

Servo control loop, 60

Servo setup, 82

SETUPFB setup motor feedback, 96

Short circuit protection, 28

Simulated encoder I/O, 39

Simulated encoder I/O circuits, 40

SM motor

- cables, 19

SN system variable, 55

Software installation, 70

Software requirements, 69

ST

- bit order, 56
- system variable, 56
- word, 56

Star point, 9

STATUS, 97

Status Bit description, 56, 103

Status report example, 83

Status variable

- byte reporting, 56

Status variable reporting, 56

Step direction inputs, 53

Step direction outputs, 53

Step up step down inputs, 53

Step up step down outputs, 53

Supply

- connections, 10
- current, 11
- volts, 11

SV save configuration, 98

Syntax checking, 87

System variables, 49, 85

  reading, 49

  reporting status, 56

  table of, 50

  writing, 49

## **T**

Temperature

  ambient, 113

  storage, 113

Terminal menu, 74

Thermal limitations of DIN rail mount, 7

TL system variable, 55

Torque de-rating, 7

Transformer

  sizing for applications, 116

Transformer selection guide, 116

## **U**

UF byte, 59

User fault

  byte reporting, 59

  clear conditions, 59

  descriptions, 59, 103

  reporting, 59

User faults, 57

Utilities menu, 74

## **V**

Velocity gain, 54

ViX

  supply current, 11

  supply volts, 11

ViX250/500 drive

  dimensions, 6

## **W**

W write system variable, 99

Weight, 113

Welcome box, 70

Windows menu, 74

Windows™, 69

Wire size of motor earth, 28

Withstanding voltage rating, 115

## **X**

X1 connector, 32

X1 connector pin-out, 32

X1 mating connector type, 32

X2 connector, 34

X2 connector pin-out, 34

X2 connector type, 34

X3 connector, 35

X3 connector pin-out, 36

X3 connector type, 35

X4 connector, 39

X4 connector pin-out, 39

X4 connector type, 39

X5 connector, 42

X5 connector pin-out, 42

X5 connector type, 42

X6 & X7 connections, 45

X6 & X7 position, 44

XL-PSU

  product description, 13

XL-PSU drive wiring diagram, 14

XL-PSU mounting information, 15

## **Z**

Z reset, 99

---



---

## Customer Feedback

---

If you have spotted any errors, omissions or inconsistent information within this user guide please let us know. Either use this page (or a photocopy) to describe the error and Fax. it to the number given below. Alternatively, you may phone or email the correction.

**Name of user guide:**

**Part number:** 1600. \_ \_ \_ . \_ \_ Found on the title page in the bottom left corner.

**Your name:**

**Contact number or email address:**

**Description of the error: (Please include page number)**

Errors can be reported  
by Fax:

**+44 (0)1202 695750**

By phone, via a technical  
support engineer:

**+44 (0)1202 699000**

Or by email:

**support.digiplan@parker.com**



# VIX AH SERVO DRIVE USER GUIDE

