



How to Get Oil Free Compressed Air from an Oil Free Compressor

A White Paper By Mark White - Compressed Air
Treatment Applications Manager



ENGINEERING YOUR SUCCESS.

www.parker.com/gsf

Oil Free Compressed Air

In this white paper, Mark White, Compressed Air Treatment Applications Manager at Parker Hannifin, explains the misconceptions that accompany the installation of an oil-free compressor, the contamination risks associated with oil-free compressors, and how to mitigate those risks by installing the correct purification equipment required to deliver clean, “Technically Oil Free Compressed Air”.

In today’s modern production facilities, the use of compressed air is often pivotal to manufacturing processes. Irrespective of whether the compressed air comes into direct contact with the product or is used to automate a process, provide motive power, package products, or even to generate other gases on-site, a clean, dry, reliable compressed air supply is essential to maintain efficient and cost effective production.

There are many different types of air compressor available today, and most compressor technologies are now available as an oil-free variant.

Due to its efficiency and reliability, the rotary screw compressor has firmly established itself as the technology of choice for many industries and applications.

In order to promote oil-free compressors, marketing messages are often aimed specifically at industries such as food, beverage, pharmaceutical, and electronics and play on the fear that oil is the biggest contamination threat they face from compressed air. A threat that can be eliminated simply by installing an oil-free compressor.

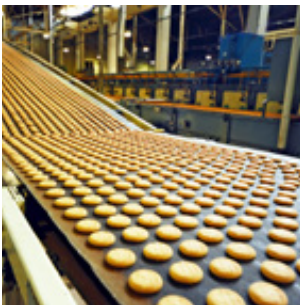

Unfortunately, during selection, purchase and installation of an oil-free compressor, the downstream air treatment system is often neglected or overlooked completely. For this reason, many users are disappointed to find that oil contamination and water are still present after the installation of their new compressor.

This paper has been developed to provide the reader with an understanding of where oil and other contaminants originate in a compressed air system and how to achieve clean, oil-free compressed air for critical applications.

Where does oil come from in a compressed air system?

The oil found in a compressed air system will enter from two main sources:

- Contamination Source 1 - the ambient air (oil vapour)
- Contamination Source 2 - the air compressor (liquid oil / oil aerosols / oil vapour)

Left untreated, oil in one or more of the 3 phases will contaminate the air receiver and distribution piping. It can therefore be said that indirectly, the air receiver and piping are additional sources of oil contamination (3 & 4).

- Source 3 – The Air Receiver
- Source 4 – The Distribution Piping

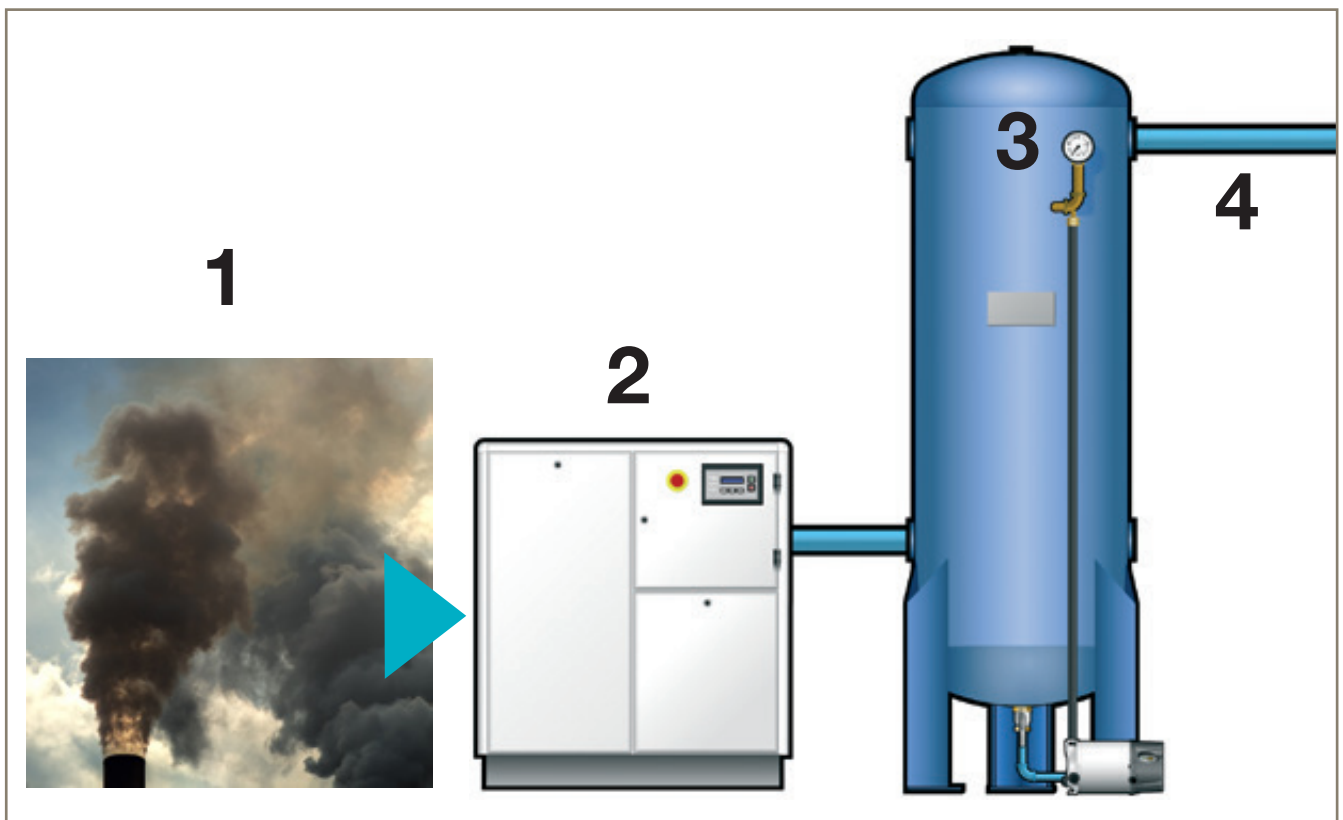

Contamination Source 1 - The Ambient Air

Ambient air contains oil in a gaseous form (oil vapour). The oil vapour in ambient air is actually a combination of hydrocarbons and VOC (Volatile Organic

Compounds) which come from natural sources as well as from vehicle exhausts and inefficient industrial processes.

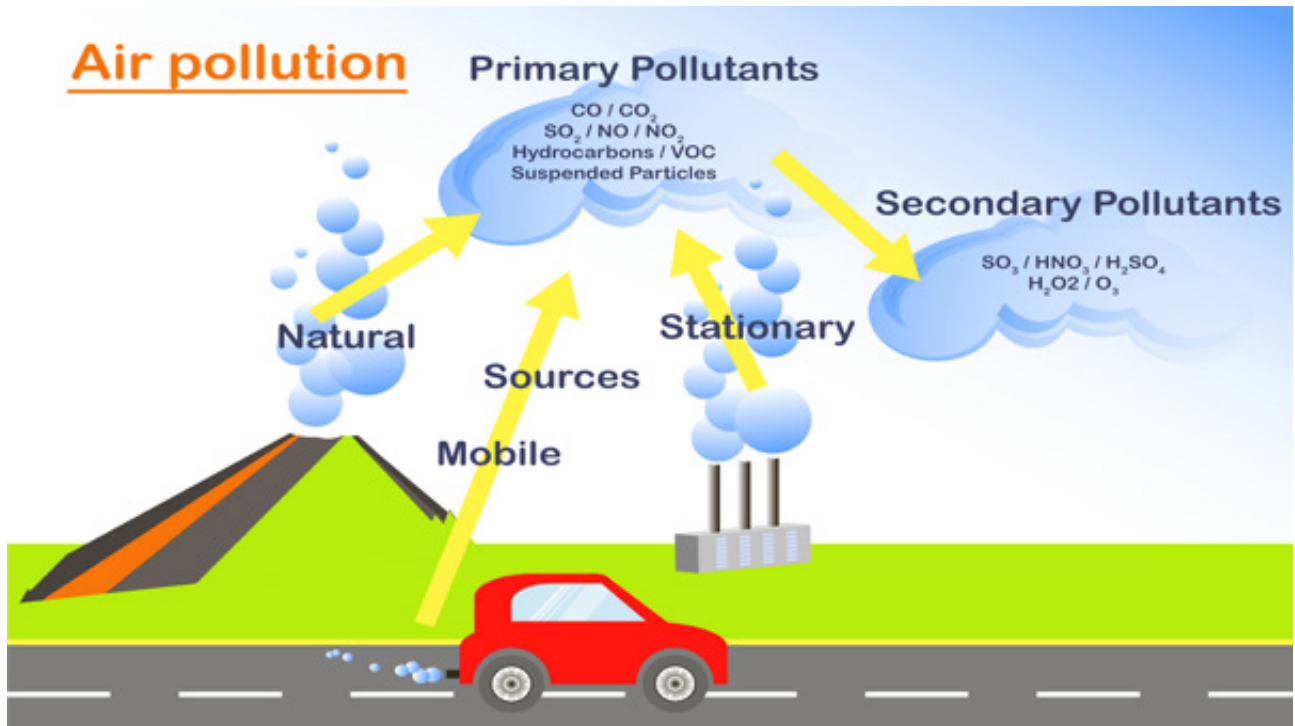

How much “Oil Vapour” is in the ambient air?

Typical values quoted for oil vapour contamination state that 1 cubic meter of ambient air typically contains between 0.05mg/m³ and 0.5mg/m³ of oil vapour.

This however can be higher in dense, urban or industrial environments or next to car parks and busy roadways.

Oil vapour levels are difficult to measure as there is no single “oil” in air test available (at least not a very accurate one). Therefore for accuracy, one must test the ambient air for the different compounds and combine the test results.

Global targets to improve air quality has led to many air quality sample stations being set up. These typically test for the compounds which are more harmful to human health (NO_x, SO_x, CO, CO₂ & Ozone).



A number of these facilities also test for additional compounds, especially the VOC. We can therefore use this data to verify the presence of “Oil Vapour” in the ambient air.

Independent Test Data

In the United Kingdom, DEFRA (Department for Environment, Food and Rural Affairs) freely publishes data obtained from their UK sampling facilities. Most of these sites (30+) use manual sampling and test methods, looking for specific hazards, whilst 4 sites (2

rural & 2 urban) use sophisticated automated thermal desorption with in situ gas chromatography and FID detection equipment. At these sites, automatic hourly measurements are made of 29 different “target” compounds.

Totals for the 29 Compounds of Interest	Maximum Hourly Concentration - Year 2012			
	Auchencorth Moss	Harwell	Eltham	Marylebone Rd
Totals (mg/m ³)	0.37	0.16	0.44	0.86

Totals for the 29 Compounds of Interest	Maximum Hourly Concentration - Year 2013			
	Auchencorth Moss	Harwell	Eltham	Marylebone Rd
Totals (mg/m ³)	0.34	0.12	0.44	0.57

Totals for the 29 Compounds of Interest	Maximum Hourly Concentration - Year 2014			
	Auchencorth Moss	Harwell	Eltham	Marylebone Rd
Totals (mg/m ³)	0.26	0.20	0.64	0.74

Totals for the 29 Compounds of Interest	Maximum Hourly Concentration - Year 2015			
	Auchencorth Moss	Harwell	Eltham	Marylebone Rd
Totals (mg/m ³)	0.16	0.08	0.40	0.51

As can be seen in the tables above, when the recorded data for all 29 compounds is combined, it corroborates the typical industry figures used for oil (hydrocarbons) in ambient air of between 0.05 mg/m³ - 0.5 mg/m³.

Important Notes Regarding DEFRA results:

- Global and EU reports only target substances of concern or those which are hazardous to human health.
- They do not necessarily measure compounds hazardous to process health e.g. the taste of a product that is in direct contact with compressed air during manufacture).
- Many species (compounds) which are less (or not) harmful to human health, slip through the detection net, as the chemist / analyst isn't looking for them and has no interest in them.
- These chemicals still exist in the ambient air and their contribution to the “true” total VOC level is lost (but must always be considered).
- The reported VOC level is therefore much lower than reality.
- From the summary tables, we can see that some sites are within the typical values of between 0.05mg/m³ and 0.5mg/m³, whilst one exceeds these typical values.
- As the test sites used by DEFRA and highlighted in their reports are not testing for every VOC, only those of interest, the values in the summary tables should therefore be viewed as “best case”.

How does the ambient oil vapour contaminate the compressed air?

As the compressor is running, large volumes of ambient air are drawn into the compressor intake. This ambient air may look clean, but it is not as the gaseous contaminants often cannot be seen.

The invisible oil vapour present in the ambient air is therefore sucked into the air compressor intake along with other contamination.

Once in the compressed air distribution system, some of the oil vapour will cool and condense to form liquid oil and oil aerosols.

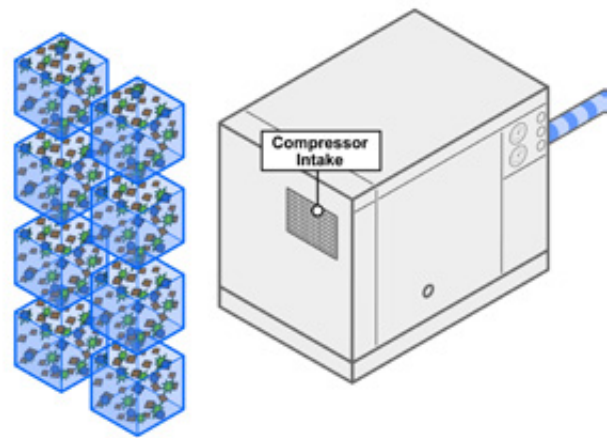

When Compressing Air, The Problem Increases

To many, the ambient levels of 'oil vapour' may be considered "negligible", however when we talk about oil vapour in the compressed air, we must also consider the effect that compressing the air has on the ambient contamination, the amount of air flowing into the compressed air system and the length of time the compressor is operating.

Compression = Concentration

When the ambient air is compressed, it is "squeezed" down into a smaller volume. Unfortunately, this does not apply to the contaminants in the ambient air which instead are concentrated. The higher the pressure the air is compressed to, the higher the concentration of contamination.

Typical values quoted by the compressed air industry for oil vapour in ambient air are between 0.05 mg/m³ & 0.5 mg/m³

Recorded values are shown to confirm these values or are in fact higher.

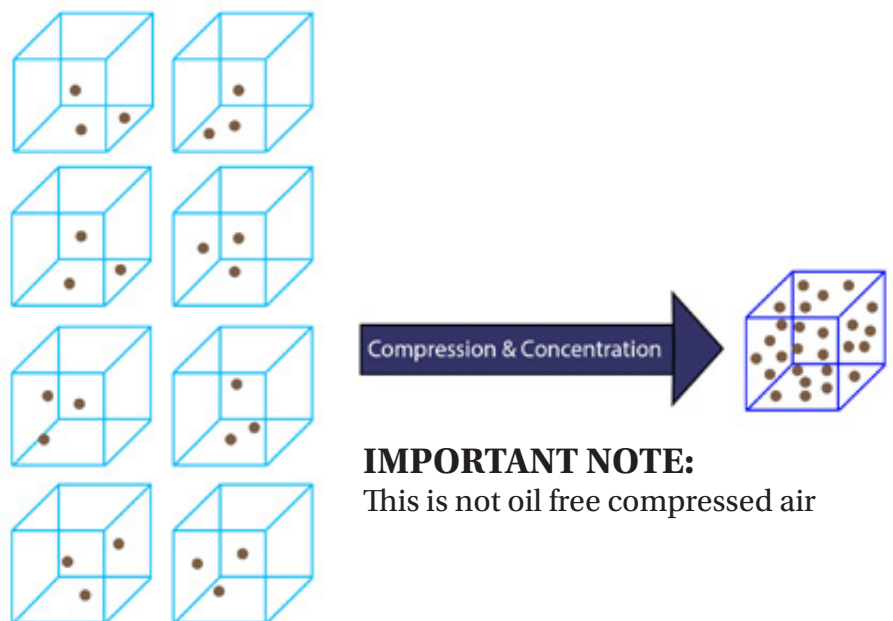

IMPORTANT NOTE:
This is not oil free compressed air

Concentration Examples

To highlight the effect of concentration, the table below contains the maximum hourly oil vapour concentration values from page 5 (averaged from the values recorded over the 4 years).

Recorded Contamination Levels in 1 Cubic Meter of Ambient Air Before Compression

Pressure	Industry Values		Recorded Ambient Values (Averages over 4 years)			
	Min	Max	Auchencorth Moss	Harwell	Eltham	Marylebone Rd
0 bar g	0.05	0.5	0.29	0.14	0.48	0.67

The table below highlights the increased 'oil vapour' contamination levels that 1 cubic meter of *compressed* air would contain (at industry typical operating pressures).

Oil Vapour Contamination Levels 1 Cubic Meter of Compressed Air

Pressure	Industry Values		Effect of Compression on Recorded Ambient Values			
	Min	Max	Auchencorth Moss	Harwell	Eltham	Marylebone Rd
7 bar g	0.40	4.00	2.32	1.12	3.84	5.36
10 bar g	0.55	5.50	3.19	1.54	5.28	7.37
13 bar g	0.70	7.00	4.06	1.96	6.72	9.38
40 bar g	2.00	20.0	11.6	5.6	19.2	26.8
All Concentration Values in mg/m ³						

Negligible Values

So, what may appear as negligible values in the ambient air, are no longer negligible once the concentrating effects of compression is taken into consideration.

Volumetric Flow & Time

Another consideration is the volumetric flow rate of the air compressor. Most people look at the figures per cubic metre of ambient air and forget to work out how many cubic metres per hour their air compressor is delivering into their distribution piping system. Air compressors are constantly operating, constantly drawing in the contaminated air and constantly adding to the concentration of contamination.

Compressor Intake Location

We have discussed the levels of oil vapour in the ambient air, however there is also another factor to consider and this is the proximity of the compressor intake to car parks and roads. It is extremely common to find air compressors installed next to a car park, site transportation hubs (goods in / out) or major roads & motorways. The effect of vehicular movement next to the compressor intake raises the risk associated with harmful VOC considerably, especially if a vehicle can park or wait with its engine running right next to the compressor intakes.



Contamination Source 2 - The Air Compressor

Overview of Screw Compressor Operation

Oil Free

The obvious thought is that the term 'Oil free compressor' describes a compressor containing no oil. Unfortunately, that is not the case for most oil free compressors. An oil free compressor is the term used to describe a compressor that does not use oil in its compression stage.

Basic Operation - Oil Free Rotary Screw Compressor

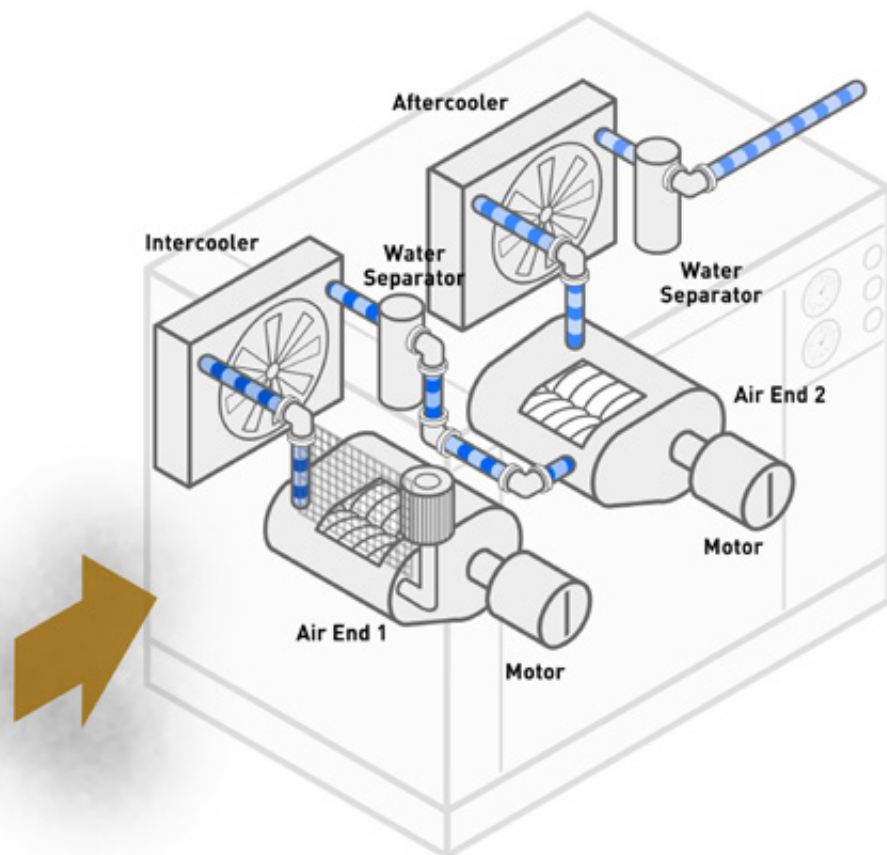

Drive

Oil free rotary screw compressors are typically multi stage, driven by a single drive motor. This motor will drive a gear which in turn distributes the power to each air end. Some oil free screw compressors are now available where each compression stage driven by an individual motor

Compression

Unlike the oil injected screw compressor which uses oil to seal the gaps between the rotors and provide compression, oil free variants achieve compression in an alternative way.

Rotor elements are manufactured in pairs with extremely tight tolerances to decrease the gap between them. During operation, rotors are spun at much higher speeds than an equivalent oil injected compressor. Specialist coatings are often applied to the rotors to give some of the protection from water and heat usually provided by oil.

The rotors operate extremely close to each other, however as there is no oil in the compression stage to prevent the rotors from touching, the distance between each rotor is maintained by additional gearing.



Cooling

As there is no oil in the compression chamber to provide direct cooling, indirect cooling is used. The air end housings of oil free compression stages typically contain galleries in which cooling water (on water cooled machines) or oil (on air cooled machines) can be circulated. This process is not as efficient as direct cooling as it only cools the casing and not the compressed air or the rotors.

Due to the lack of direct cooling in an oil free compressor, the compressed air and rotors reach much higher temperatures. Oil-free compressors therefore obtain their final discharge pressure in stages (as opposed to oil injected machines which typically use only 1 stage). Between stages they will cool the compressed air with an inter-cooler. This keeps typical air end temperatures between 180°C & 200°C.

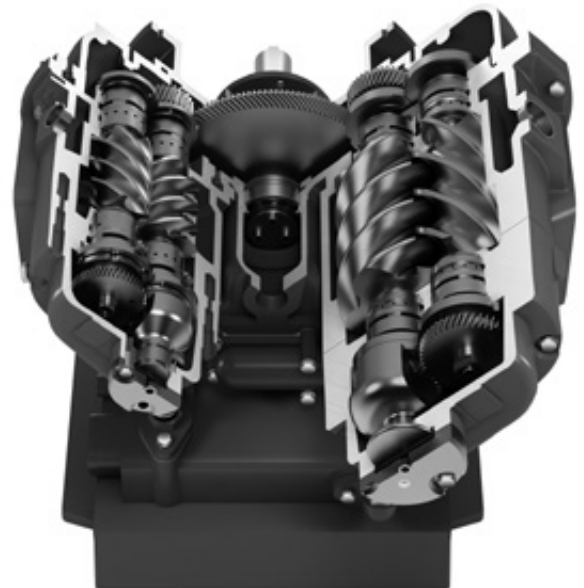

For example, on a typical oil free rotary screw compressor with 2 compression stages, an intercooler and aftercooler. Stage 1 will typically compress the air up to a pressure around 3.5 bar g, stage 2 will then compress the air to the discharge pressure of 7 bar g.

Lubrication

On an oil free screw compressor, it is not only important that the individual rotors in each air end are synchronised with gears, with only one drive motor, additional gearing is also required to drive each of the air ends. All of the gearing and bearings require lubrication.

So although the name implies that an oil free compressor is “oil less,” for most oil free compressors sold, this is not the case. Oil is not used in the compression stages; however, oil is still required for lubrication and cooling of other components. This oil is pumped around the compressor forming a closed loop system which lubricates bearings and gears, is filtered, cooled and recirculated.

Oil Reclamation (Air / Oil Separator)

As there is no oil used in the compression stage, there is no requirement for an air / oil separator on an oil free compressor.

Overview of Screw Compressor Operation

Oil Free

Oil Carryover (from the ambient air)

It is often thought that an oil free compressor will provide oil free compressed air (due to the fact it does not use oil in the compression of the air). Unfortunately this is not true.

Oil vapours in the ambient air are drawn into the compressor intake, compressed and concentrated. The concentrated vapours then enter the compressed air distribution system where they can cool and condense. This results in the presence of oil contamination (in a liquid, aerosol and vapour phase).

The amount of oil in the compressed air downstream of an oil free compressor is primarily dependent upon the ambient air quality.

The table (right) highlights the increased 'oil vapour' contamination levels that 1 cubic meter of compressed air would contain (at typical industry operating pressures).

Additionally, many compressor intakes are sited in industrial areas and / or next to car parks and roads, where the ambient contamination levels can be significantly higher, leading to higher concentrations once compressed.



Pressure	Industry Values	
	Min	Max
Ambient	0.05	0.50
7 bar g	0.40	4.00
10 bar g	0.55	5.50
13 bar g	0.70	7.00
40 bar g	2.00	20.0

All Concentration Values in mg/m³

Oil Carryover (from the compressor)

The oil used in the closed loop system of the oil free compressor to cool and lubricate the bearings and gears heats up and vaporises during operation.

The compressor is fitted with a simple 'breather' filter to prevent over pressurisation of the oil circuit.

This breather filter allows aerosols and vapours to exit the casing and be drawn into the compressor intake, which in turn increases the amount of oil contamination going downstream.

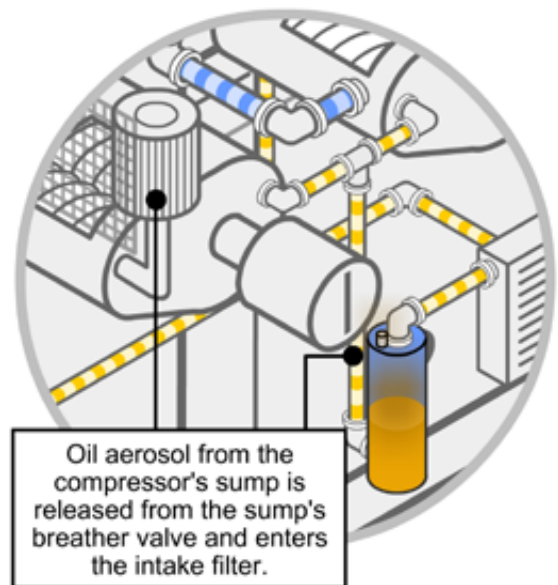

Inter-cooling / After cooling

Without the ability to provide direct cooling with oil, oil free machines typically use two compression stages. Placed in between the two stages is an inter-cooler which cools the air down. The air then enters the second compression stage where it again heats up due to compression. Before exiting the compressor, the compressed air passes through an aftercooler to cool it to a more usable level.

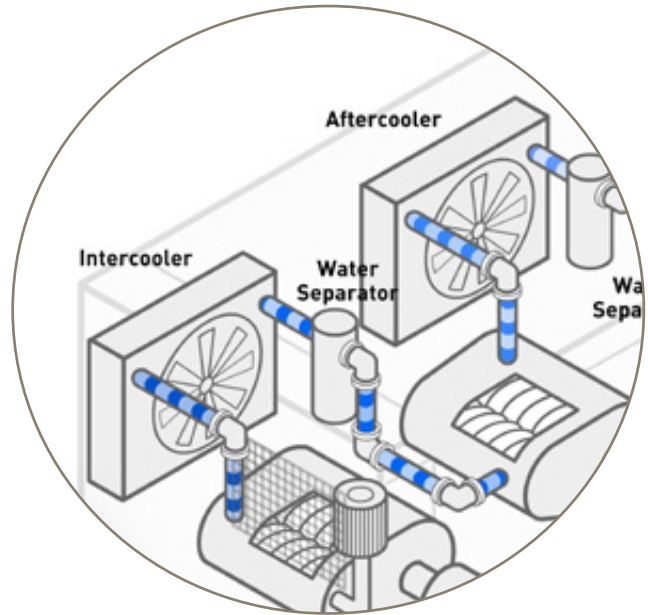

Liquid & Aerosol Introduction

As the inter-cooler and aftercooler cool the compressed air, it reduces the air's ability to hold water and oil vapours. Cooling condenses the vapours into liquid water and liquid oil which is carried along in the air at high velocity. Rough internal surfaces of the piping, bends, elbows, fittings, etc. all disrupt the flow of condensed liquids. This disruption causes the condensed liquids to 'shear' or atomise, producing fine droplets or aerosols of water and oil.

Liquid Reduction

Many air compressors are fitted with an integrated water separator at the inter-cooler and at the outlet of the aftercooler to reduce liquids. Some compressor designs rely on an external water separator or use a wet air receiver for liquid reduction.

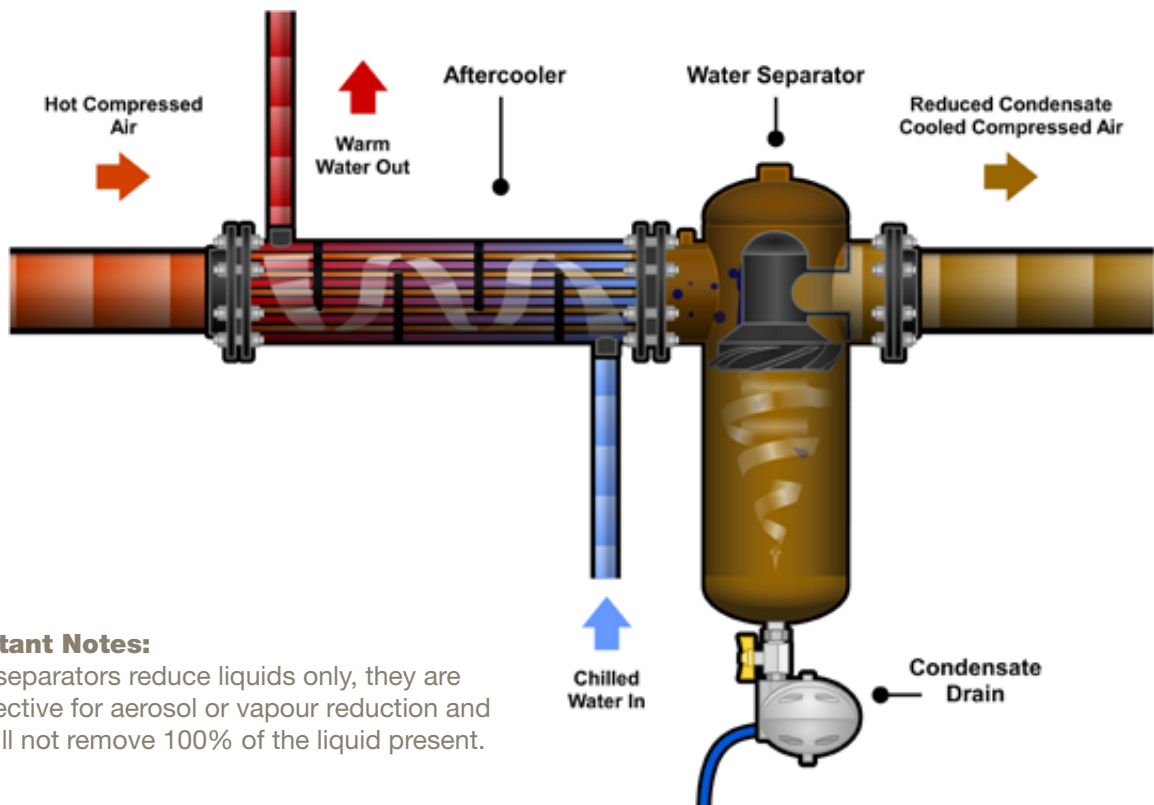

Important Notes:

Water separators reduce liquids only, they are not effective for aerosol or vapour reduction and they will not remove 100% of the liquid present.

Using International Standards to Specify Oil Free Compressed Air

ISO8573 series

ISO8573 series is the most commonly used standard for compressed air. It is made up of 9 separate parts. Part 1 refers to air purity (quality), whilst parts 2 to 9 provide details on the equipment and methodology to be used to accurately measure for different contaminants in a compressed air system (and meet the air purity classifications shown in part 1).

In ISO8573-1, compressed air contaminants are grouped into Particulate, Water and Total Oil (ISO8573 parts 2 to 9, looks at test methods by phase, i.e. water as liquid or vapour and oil as liquid, aerosol & vapour). Different levels of contamination are then assigned "Purity Classes". When using ISO8573-1 to define the air quality required at a usage point, the specification should be written as follows:

ISO8573-1 – International Standard Relating to Compressed Air Purity

ISO8573-1 provides the user a way of specifying an air purity (quality) required for the entire compressed air system and / or for individual usage points (based upon application requirements). It also allows equipment manufacturers to easily show product performance and specify purification equipment to meet the end users air purity specification.

First the standard (ISO8573-1) must be written, then the year (revision) stated then the purity classes (Separated with a colon), e.g. ISO8573-1:2010 [A:B:C]

Where:

A is the purity class for particles

B is the purity class for humidity (vapour) and liquid water

C is the purity class for total oil (aerosol, liquid and vapour)

Compressed Air Purity Classes

ISO8573-1:2010 CLASS	Solid Particulate			Mass Concentration mg/m ³	Water		Oil Total Oil (aerosol liquid and vapour) mg/m ³
	Maximum number of particulates per m ³				Vapour Pressure Dewpoint	Liquid g/m ³	
	0.1 - 0.5 micron	0.5 - 1 micron	1 - 5 micron				
0	As specified by the equipment user or supplier and more stringent than Class 1						
1	≤ 20,000	≤ 400	≤ 10	—	≤ -70°C	—	0.01
2	≤ 400,000	≤ 6,000	≤ 100	—	≤ -40°C	—	0.1
3	—	≤ 90,000	≤ 1,000	—	≤ -20°C	—	1
4	—	—	≤ 10,000	—	≤ +3°C	—	5
5	—	—	≤ 100,000	—	≤ +7°C	—	—
6	—	—	—	≤ 5	≤ +10°C	—	—
7	—	—	—	5 - 10	—	≤ 0.5	—
8	—	—	—	—	—	0.5 - 5	—
9	—	—	—	—	—	5 - 10	—
X	—	—	—	> 10	—	> 10	> 10

Class Zero / Class 0

What Is It?

Almost all oil-free rotary screw compressors are sold under the banner of Class 0. But what is it and what does it mean?

Class 0 (or Class Zero) is actually a reference to an ISO8573-1 air purity classification, although this is not always stated. It is also often referred to as an 'oil' contamination classification, when in fact it can also be applied to solid particulate and water.

When ISO8573-1 was first developed, the classification for each contaminant (particulate / water / total oil) had a value associated to it. However, in 2001, the standard was updated and Class 0 was introduced for all 3 contaminants (this carried through to the 2010 update). It was introduced as a "customisable" specification for users or manufacturers to use should the air purity requirement (users) or delivered air quality (for equipment manufacturers) be more stringent (cleaner) than Class 1.

ISO8573-1:2010 CLASS	Solid Particulate			Mass Concentration mg/m ³	Water		Oil
	Maximum number of particulates per m ³				Vapour Pressure Dewpoint	Liquid g/m ³	
	0.1 - 0.5 micron	0.5 - 1 micron	1 - 5 micron				
0	As specified by the equipment user or supplier and more stringent than Class 1						
1	≤ 20,000	≤ 400	≤ 10	—	≤ -70°C	—	0.01
2	≤ 400,000	≤ 6,000	≤ 100	—	≤ -40°C	—	0.1

Unfortunately, the ISO8573-1 Class 0 classification is often misunderstood and / or misapplied to air compressors or treatment products. It is important to remember:

- Class 0 does not mean zero contamination
- Class 0 does not mean oil-free air
- Class 0 does not solely refer to oil contamination
- A Class 0 specification must be 'cleaner' than the Class 1 specification for the contaminant chosen
- The contamination levels stated for a Class 0 specification must also be within the measurement capabilities of the test equipment and test methods shown in ISO8573 Pt 2 to Pt 9
- The Class 0 specification must clearly state which contaminant it refers to
 - i.e. "Solid Particulate", "Water" or "Total Oil (aerosol, liquid & vapour)"
- Class 0 requires the user or the equipment supplier to show a contamination level as part of a written specification

Example of a correctly written Class 0 specification

"When preceded by OIL-X Grade AO General Purpose & Grade AA High Efficiency Coalescing Filters, OIL-X OVR Grade Adsorption Filters provide a delivered air quality in accordance with ISO8573-1:2010 Class 0 (≤0.003 mg/m³) for total oil (oil aerosol & oil vapour)"

- The agreed Class 0 specification must be written on all documentation to be in accordance with the standard
- Stating Class 0 without an accompanying contaminant specification is meaningless and not in accordance with the standard

“Oil Free” Compressed Air

What does “oil free” mean and is it achievable?

“Oil-free” Compressed Air

The term oil free implies “compressed air which is free of oil” or “compressed air without traces of oil”. It is a misleading term to use and one difficult to prove or guarantee in practice.

Accurate Measurement of Oil in Compressed Air

It is not possible to accurately measure oil in compressed air down to a zero value and state that compressed air is “oil free”. A review of the relevant ISO 8573 standards will confirm this. To measure “total oil” in compressed air requires the user to test for oil aerosol & oil vapour in accordance with the methodology, and using the test equipment shown in ISO8573-2 & ISO8573-5 respectively and combine the results. The limit of accurate measurement for “total oil” is 0.003 mg/m^3 .



“Technically Oil Free Air”

What is “Technically Oil Free Air”?

Technically Oil Free Air is the term given to compressed air that has been treated to reduce the liquid oil, oil aerosol and oil vapour content to extremely low (but measurable) levels.

Technically oil free compressed air is as close to oil free compressed air as is possible, with total oil levels down to 0.003 mg/m^3 being achievable.

It is sometimes used to imply an inferior quality of compressed air compared to the so called “oil free” air delivered by an oil free compressor, when in fact the treated air will be of a higher quality.

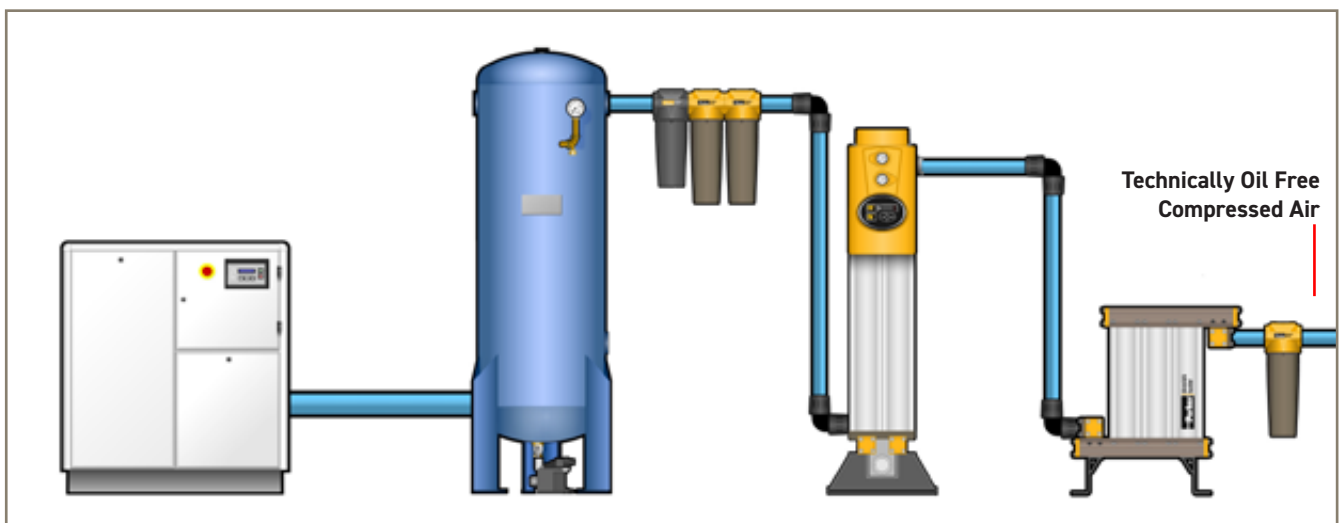

Can Oil Free Compressors Without Treatment Equipment Guarantee Oil Free Air?

Simply, no. Let's look at the facts regarding oil in a compressed air system.

Ambient Air Contamination:

Air compressors are constantly drawing in large volumes of ambient air and compressing it. The ambient air contains contamination which includes oil in a vapour phase (hydrocarbons and VOC). As the air is compressed, the contamination is not, and it is therefore concentrated. Even if ambient levels of oil vapour were low, the concentration is higher in the compressed air. Untreated, this can cool and condense in the compressed air system and point of use to produce oil in a liquid, aerosol & vapour phase at the application.

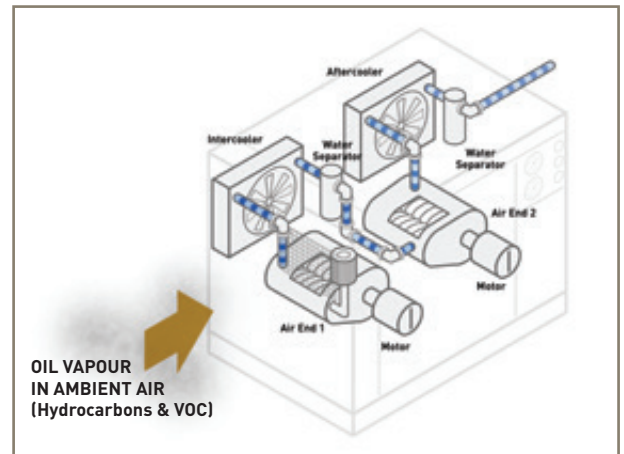

Contamination from the Oil Free Compressor:

Most oil free compressors are not "oil less", they require lubricating oil for gearboxes and bearings. Whilst the oil is not used in the compression stages, it can still find its way into the compressed air. Oil systems need to be vented and the crank case vent filter is unable to stop lubricating oil from entering the compressor intake in a vapour phase. The compressor will also use seals around bearings, however as seals wear, there is the possibility for oil to by-pass and enter the compressed air stream.

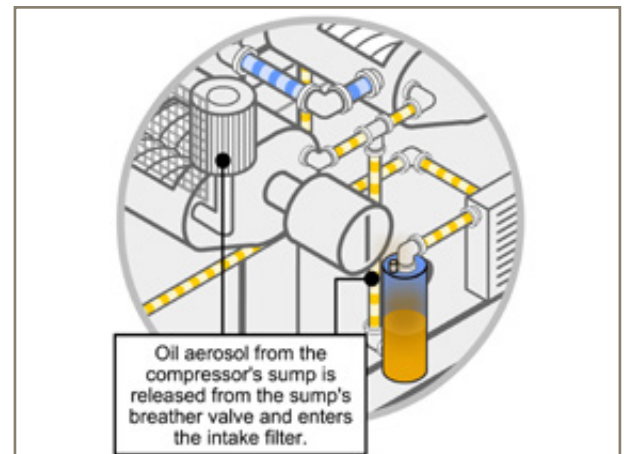

Contamination Already in the Distribution Piping System:

Even if we were to assume that the compressed air leaving the compressor was totally free from oil (which it is not), it could not be guaranteed to be so at the point of use. Piping systems will store contamination including oil and even after the installation of a new compressor and purification system, contaminants can be present at applications unless treated at the point of use. If ISO8573-1 Class 1 or Class 0 for total oil is required for an application, it is more sensible to provide this at the point of use, not in the compressor room (and often more cost effective too).



Oil free Compressor or Technically Oil Free Compressed Air?

What should I specify to protect my products, processes and brand reputation?

There are many production facilities where the compressed air directly or indirectly contacts production equipment, products or packaging materials (especially in the food, beverage,

pharmaceutical and electronics industries) and in these instances, contaminants from untreated compressed air can have a serious impact on product quality, consumer safety and brand reputation.

Common Mistakes with Specifications

It is not uncommon for manufacturers and auditors in these industries to insist that an “oil free” compressor or “Class 0” compressor be installed. This is often in the mistaken belief that the oil free compressor will guarantee oil free or contaminant free compressed air.

Offsetting Cost

These specifications often also reduce the compressed air filtration requirements (or eliminate them) as they believe the compressed air delivered by the oil free compressor has fewer contaminants or is actually free of contamination. This is also done to offset the additional cost of the oil free compressor.

Changing a facility to an oil free compressor can impose a huge cost burden which is often hidden up front. And most importantly, it is self-imposed, there is no legislation or standard for any industry stating that only oil free compressors should be installed.



Specifying Correctly

What should be specified is “Technically Oil Free Compressed Air”, i.e. ISO8573-1:2010 Class 1 for total Oil or ISO8573-1:2010 Class 0 (0.003 mg/m³) for Total Oil.

How Do You Achieve 'Technically Oil Free' Compressed Air?

When using an oil free compressor, if the user wishes to achieve 'Technically Oil Free' compressed air in accordance with ISO8573-1:2001 or ISO 8673-1:2010 Class 0 or Class 1 for Total Oil, purification equipment is required downstream of the compressor.

Installing purification equipment such as liquid separators, coalescing filters and adsorption filters, will ensure treatment of the 'oil' vapour drawn into the compressor intake (including the vapour which condenses to form liquid oil and oil aerosols).

Additionally, they will also treat other contaminants present in the compressed air.

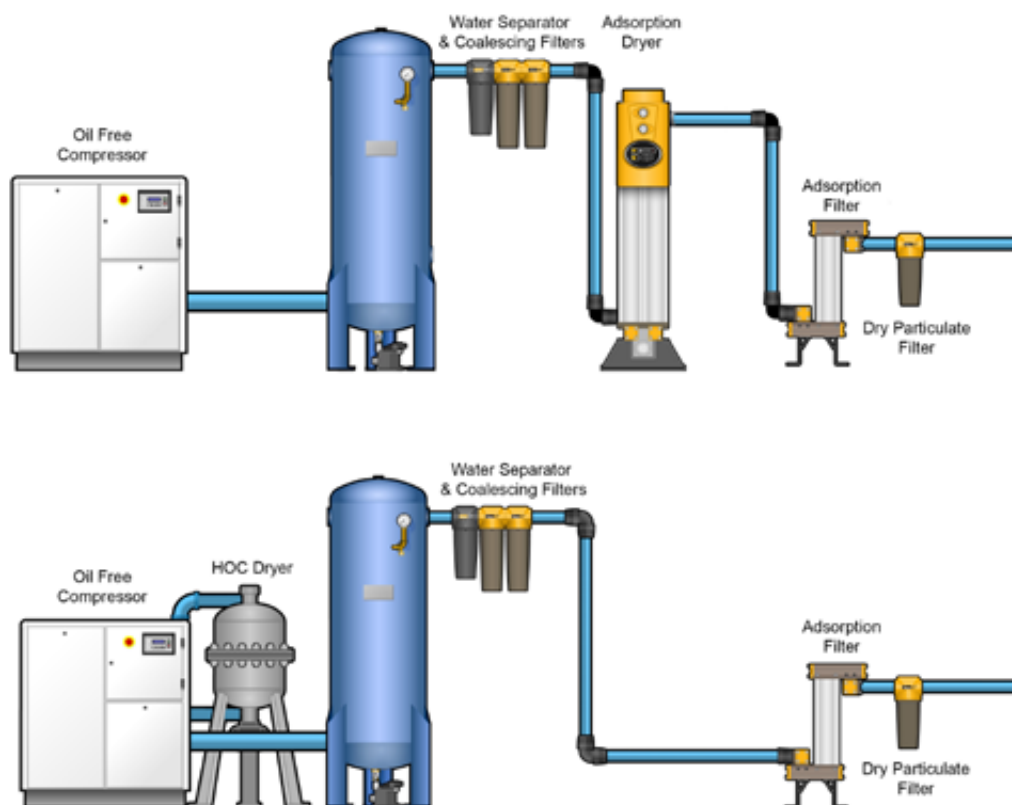

Where to Specify Technically Oil Free Compressed Air

Where should I specify my highest air quality requirements, in the compressor room or at the point of use?

To achieve “Technically Oil Free Compressed Air” requires a careful approach to system design. Any air quality specification should look at treating the air both in the compressor room (to a level enough to

protect the distribution piping from contamination and provide general purpose air) and include additional treatment at each point of use (to protect critical applications).

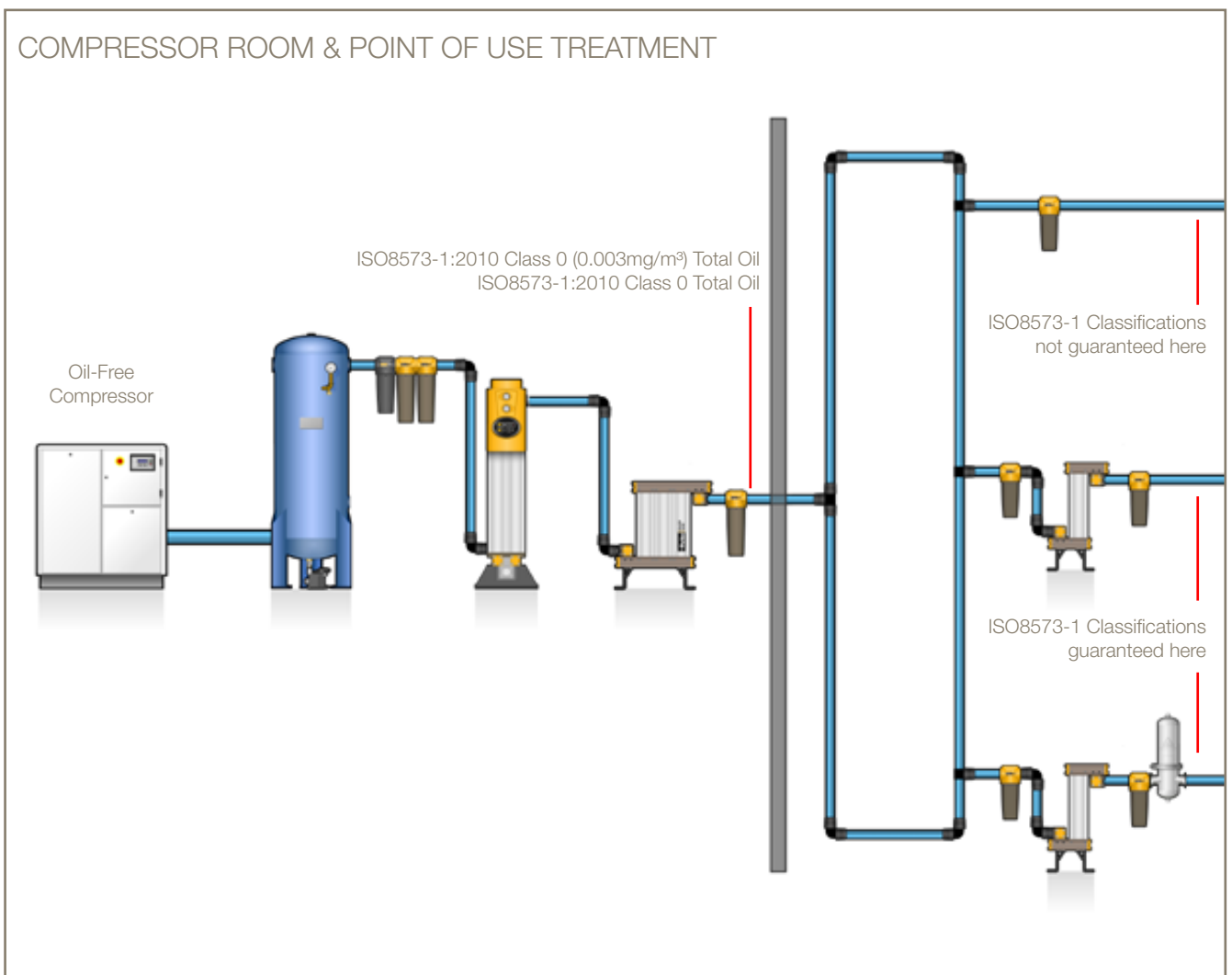

Important Note: Compressor room air purity can be equal to the desired point of use air purity (as shown above) or of a lower specification and brought up to the desired specification with point of use purification equipment.

Treatment only in the compressor room will allow the compressed air to pick up contamination in the piping system (including oil, particulates and micro-

organisms). The ISO air purity specified will be at the last filter only and not at the point of use.

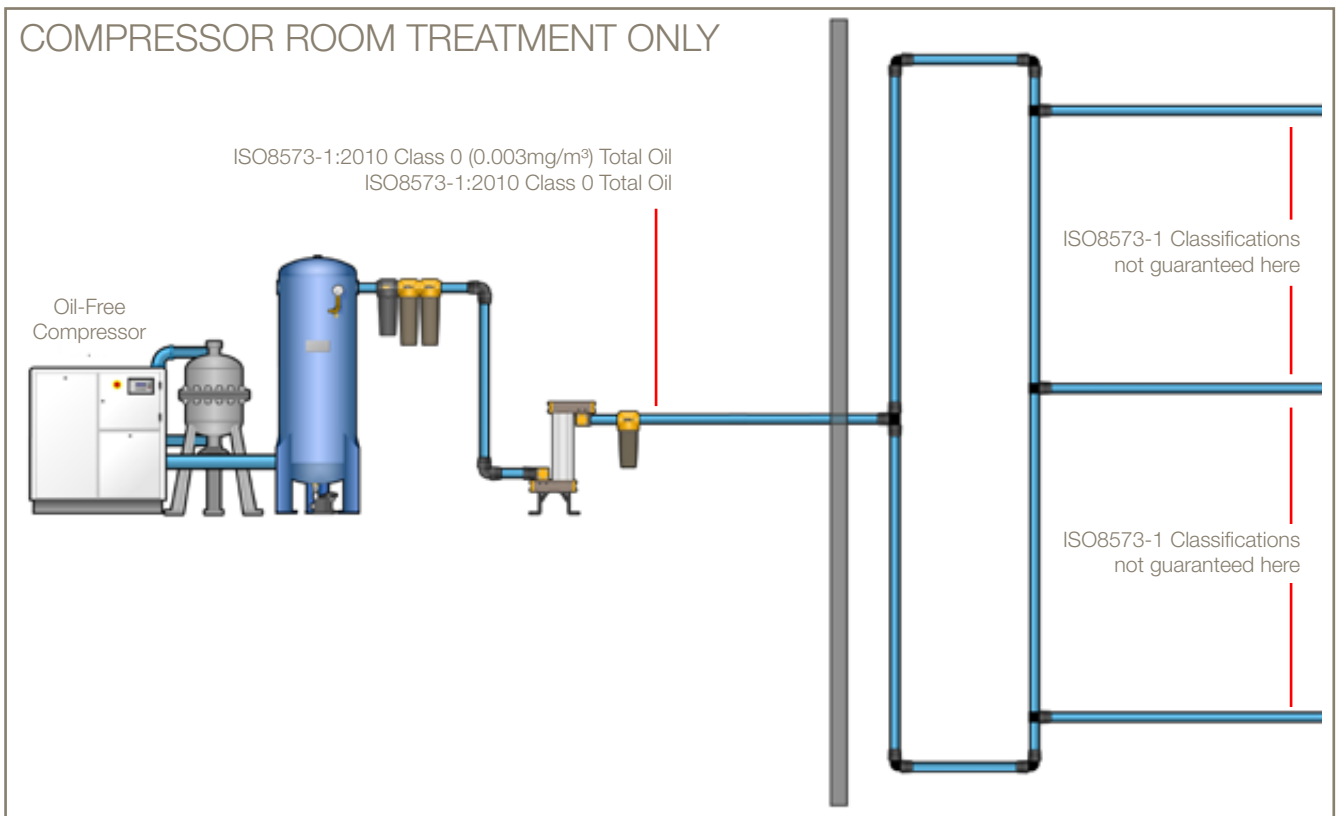
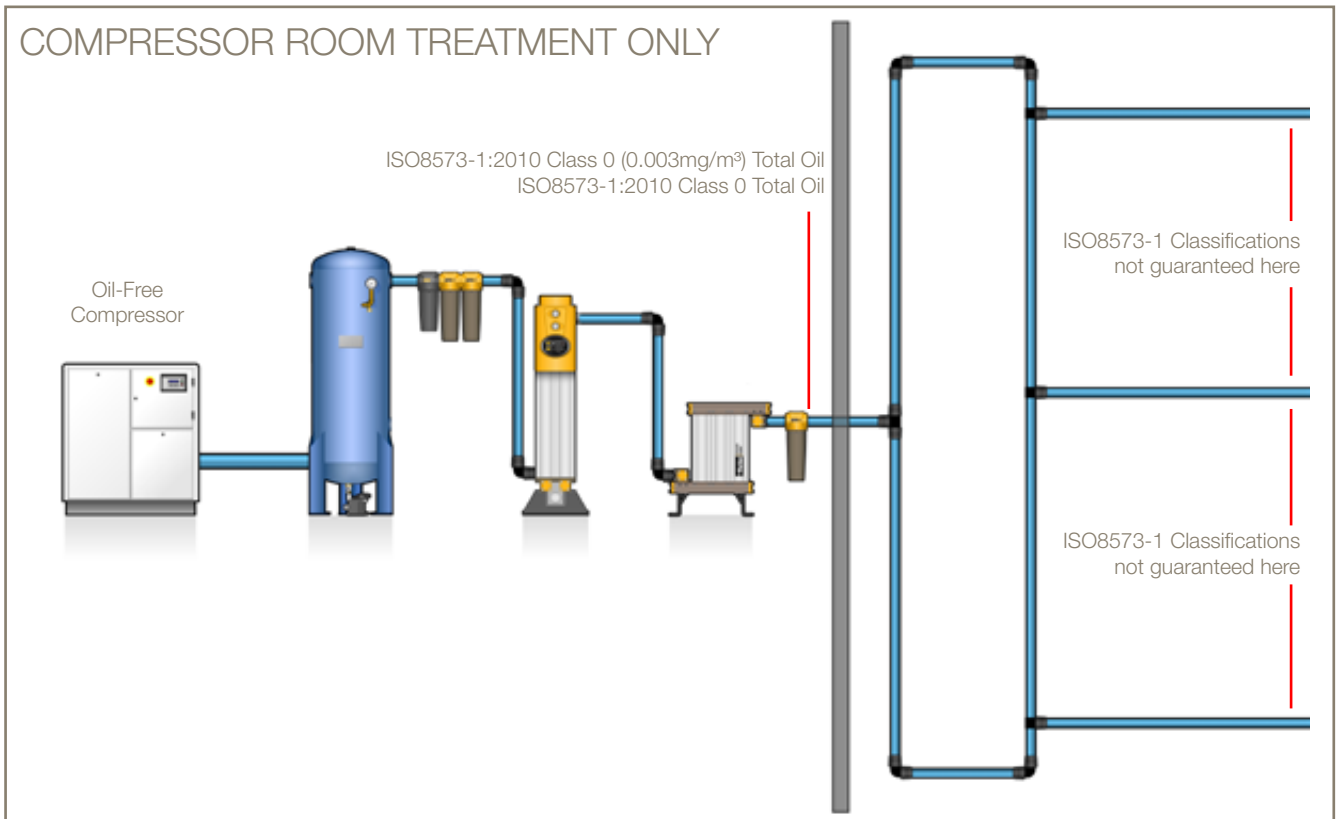

It's Not All About Oil

Oil in a compressed air system is not the biggest concern for users. There are a minimum of 10 contaminants found in a compressed air system that require treatment and they come from four different sources (not solely from the compressor).

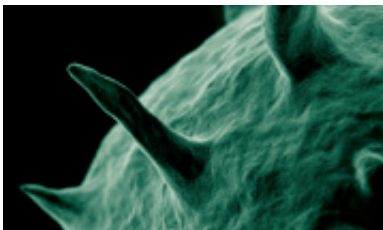
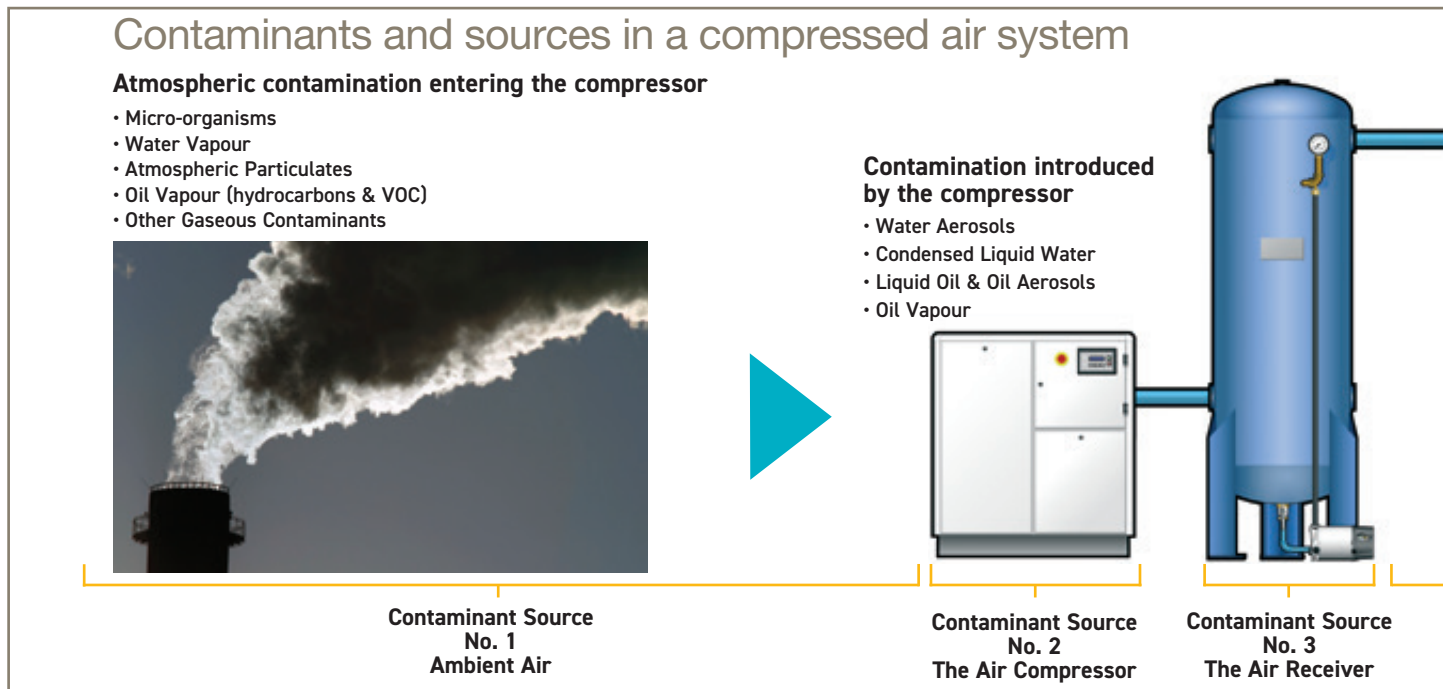

Micro-organisms

Ambient air can contain up to 100 million micro-organisms per cubic metre. Due to their small size, bacteria, viruses, fungi, yeast and spores will all pass through the intake filter and into the compressed air system. The warm moist environment inside the air

receiver and distribution piping provides an ideal environment for their rapid growth. Microbial growth is significant in compressor condensate and care must be taken when discharging condensate.

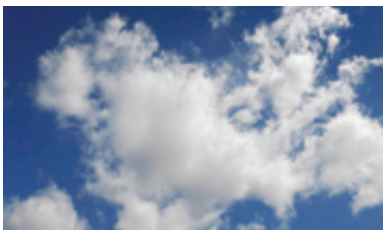

Water vapour

Water enters the compressed air system as a vapour (gas). The ability of air to hold water vapour is dependent upon its pressure and its temperature. The higher the temperature, the more water vapour can be held by the air, the higher the pressure, a greater amount of

water vapour is squeezed out. As ambient air is compressed, the temperature of the air increases significantly allowing the heated air to easily retain all of the water vapour entering the compressor.



Oil vapour

Vehicle emissions and inefficient industrial processes lead to oil vapour contamination in the ambient air. Typical concentrations in ambient air can seem low (between 0.05 and 0.5mg per cubic metre), however values measured in compressed air increase significantly after compression when

contaminants become concentrated. Once in a compressed air system, oil vapour can taint ingredients, finished products and packaging with an oily smell. Cooling also causes oil vapour to condense into liquid oil and form oil aerosols.

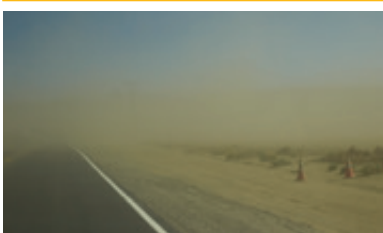

Atmospheric particulate

Ambient air in industrial and urban environments will typically contain between 140 & 150 million dirt particles in every cubic metre. As 80% of these particles are less than 2 microns in size, they are therefore too small

to be captured by the compressor air intake filter and will travel unrestricted into the compressed air system.

Ambient air is laden with many unseen contaminants which are drawn into the compressor intake. Once in the compressed air system, many of the hazards found in ambient air change phase, leading to the creation of additional contaminants.

Contamination introduced by the air receiver and distribution piping

- Rust
- Pipescale

Total contamination entering the compressed air distribution system

- Micro-organisms
- Water Vapour
- Atmospheric Particulates
- Oil Vapour (hydrocarbons & VOC)
- Water Aerosols
- Condensed Liquid Water
- Liquid Oil
- Oil Aerosols
- Rust
- Pipescale

**Contaminant Source
No. 4
The Distribution Piping**



Liquid water and water aerosols

After compression, compressed air is cooled to a usable temperature by an after-cooler. This cooling reduces the air's ability to retain water vapour, resulting in condensation of water vapour into liquid water. The presence of liquid also causes aerosols to be formed. After-coolers typically incorporate a water separator to reduce the amount of liquid entering the compressed air system (these do not remove 100% of the condensed liquid and have no effect on aerosols).

The air leaving the after-cooler and entering the compressed air system is now 100% saturated with water vapour. Any further cooling of the compressed air will result in more water vapour condensing into liquid water and the generation of more aerosols. Condensation occurs at various stages throughout the system as the air is cooled further by the air receiver, the distribution piping and the expansion of air in valves, cylinders, production equipment.



Liquid oil and oil aerosols

As with water, oil vapour drawn in with the ambient air is cooled and condensed within the after-cooler leading to the formation of liquid oil and oil aerosols (even with oil-free compressors) which carry downstream. The majority of air compressors in use today use oil in their compression stage for sealing, lubrication and cooling.

Even though the oil is in direct contact with the air as it is compressed, due to the efficiency of modern air / oil separators built into the compressor, only a small proportion of this lubricating oil is carried over into the compressed air system as a liquid or aerosol (typically no more than 5mg/m³ for a well maintained screw compressor) or as oil vapour.



Rust and pipescale

Rust and pipescale can be directly attributed to the presence of water in the compressed air system and is usually found in air receivers and distribution piping. Over time, the rust and pipescale breaks away to cause damage or blockage in production equipment which can also contaminate final product and

processes. Rust and pipescale problems often increase for a period of time after the installation of dryers into older piping systems which were previously operated with inadequate or no purification equipment.

Contaminant Reduction

To operate any compressed air system, safely and cost effectively, contamination must be reduced to acceptable limits.

Poor compressed air quality and failure to control contamination can cause numerous problems for an organisation, many of which are not immediately associated with contaminated compressed air.

Product

- Contaminated raw materials
- Contaminated products
- Contaminated packaging
- Spoiled products

Consumer

- Potentially unwell / seriously ill consumers
- Unhappy customers

Manufacturer

- Brand damage
- Legal actions
- Financial loss
- Potential imprisonment (in certain industries)

Manufacturing Process

- Inefficient production processes
- Reduced production efficiency
- Increased manufacturing costs
- Failed quality audits (in certain industries)

Compressed Air System

- Growth, storage & distribution of microbiological contamination
- Corrosion within storage vessels and the distribution system
- Contaminated / damaged production equipment
- Blocked or frozen valves & cylinders
- Premature unplanned desiccant changes for adsorption dryers
- High operational and maintenance costs

Contaminant control

Ensuring effective control of compressed air contamination, requires a number of purification technologies. To many compressed air users, the realisation that there are ten major contaminants in a compressed air system is somewhat of a surprise. It is often thought that only three contaminants are present (Dirt / Water / Oil), however as those contaminants

can be found in many phases, they therefore require a specific purification technology for efficient reduction.

The table below highlights filtration & drying technologies that comprise the purification system and the contaminants they reduce.

Purification Technologies	Contaminants								
	Atmospheric Particles	Rust & Pipescale	Micro-organisms	Liquid Water	Water Aerosol	Water Vapour	Liquid Oil	Oil Aerosol	Oil Vapour
Water Separator				●			●		
Coalescing Filters	●	●	●		●			●	
Adsorption Filters									●
Dryer						●			
Dry Particulate Filters	●	●	●						
Sterile Filters*			●						



A solution for every contaminant

Compressor Room

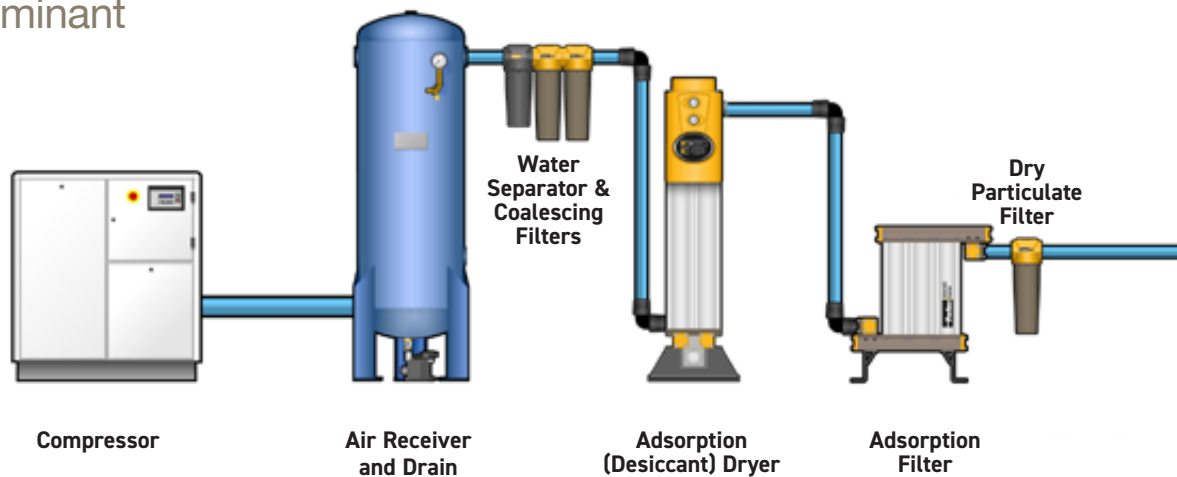

Water separators

Although called water separators, they reduce the content of all liquids at the point of installation. Liquid in a compressed air system is usually a mixture of oil and water (even when using an oil free compressor).

Water separators are usually the first piece of purification equipment installed downstream of an after-cooler or wet air receiver and should be used to protect coalescing filters from liquid contamination. They will only reduce liquids and will have no effect on water or oil in an aerosol or vapour phase.

Coalescing filters

When considering purification equipment, coalescing filters are vital for the cost effective operation of any compressed air system, regardless of the type of compressor installed.

A purification system will normally consist of two coalescing filters installed in series to remove water aerosols, oil aerosols, atmospheric particulate, micro-organisms, rust and pipscale.

Compressed air dryers

Water vapour is water in a gaseous form and will pass through water separators and coalescing filters just as easy as the compressed air. Water vapour is therefore removed from compressed air using a dryer. The water vapour removal efficiency of a dryer (its performance) is expressed as a Pressure Dewpoint or PDP.

- Dewpoint refers to the temperature at which condensation will occur.
- Pressure Dewpoint or PDP refers to the dewpoint of air above atmospheric pressure.
- Dewpoint is expressed as a temperature (however this is not the temperature of the air).
- Compressed air with a PDP of -20°C , would need the temperature to drop below -20°C for any water vapour to condense into a liquid.
- A PDP of -40°C is recommended for all food, beverage & pharmaceutical applications where air is directly or indirectly contacting production equipment, ingredients, packaging or finished products because a PDP better than -26°C will not only stop corrosion, it will also inhibit the growth of micro-organisms.

Adsorption dryer

Adsorption dryers reduce water vapour in compressed air by passing air over a regenerative desiccant material which strips the moisture from the air. This method of drying is extremely efficient. A typical pressure dewpoint specified for an adsorption dryer is -40°C as it not only prevents corrosion, more importantly it also inhibits the growth of micro-organisms.

There are many types of adsorption dryer available and whilst they all use the same principle to remove moisture from compressed air, there are a number of different methods used for

the regeneration of the wet adsorbent material. For food and beverage applications, care should be taken when selecting an adsorption dryer as some regeneration methods used may have an impact on the contamination levels of the compressed air.

Refrigeration dryers (not shown)

Refrigeration dryers work by cooling the compressed air further and condensing the water vapour into a liquid for removal by a water separator.

Refrigeration dryers are limited to positive pressure dewpoint to prevent freezing of the condensed liquid and are typically used for general purpose industrial applications with indoor piping. They should also not be used in any facility where piping is installed in ambient temperatures below the dryer dewpoint i.e. systems with external air receivers or piping.

Adsorption filter

To ensure 'technically oil free air', adsorption filters are employed which utilise a large bed of activated carbon adsorbent for the effective reduction of oil vapour.

The combination of coalescing filters and adsorption filters will provide compressed air to the highest air quality classifications of ISO8573-1, the international standard for compressed air quality.

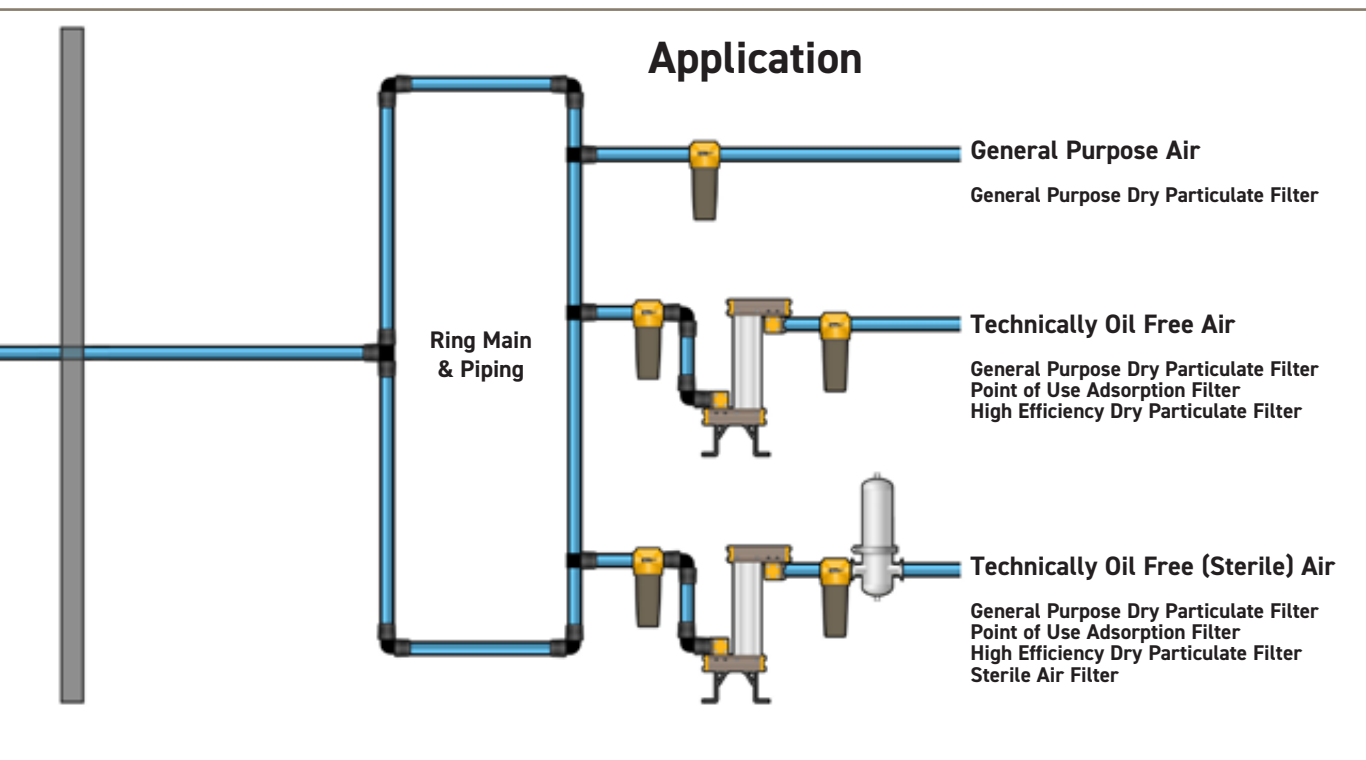

Dry Particulate filters

Dry particulate filters provide identical particulate removal performance to the equivalent grade coalescing filter. Relying on mechanical filtration techniques, high efficiency dry particulate filters can provide particle reduction down to 0.01 micron with a removal efficiency of 99.9999%. When coupled with a -40°C Pressure Dewpoint, to inhibit and control the growth of micro-organisms, they can provide significant reduction of microbiological contaminants.

Sterile filters

Absolute (100%) removal of solid particulates and micro-organisms is performed by a sieve retention or membrane filter. They are often referred to as sterile air filters as they also provide sterilised compressed air. Filter housings are manufactured from stainless steel to allow for in-situ steam sterilisation of both the filter housing and element. It is important to note that the piping between the sterile filter and the application must also be cleaned and sterilised on a regular basis.

Important Notes:

As adsorption or refrigeration dryers are only designed to reduce water vapour and not water in a liquid or aerosol form, they require the use of coalescing filters to work efficiently.

Suppliers of oil-free compressors will often state that one of the coalescing filters is a particulate filter and the other is an oil removal filter, therefore, in oil-free compressor installations, there is no need for the oil removal filter. This is not correct.

In reality, both filters remove exactly the same contaminants. The first filter is a general purpose filter which protects the second, high efficiency filter from heavy contamination.

Omitting one of the filters in the belief that it is an oil removal filter will result in poor air quality due to contaminant bypass (carryover), high operational costs due to the pressure loss across the filter and more frequent filter element changes. Most importantly, omitting one of the filters will also invalidate performance guarantees.

The dual coalescing filter installation ensures a continuous supply of high quality compressed air with the additional benefits of lower operational costs and minimal maintenance compared to a single high efficiency filter.

Refrigeration dryers are not recommended for food and beverage applications where compressed air comes into direct contact (or in-direct contact) with ingredients, production equipment, finished products or packaging as the dewpoints provided are unable to inhibit microbiological growth.

Refrigeration dryers are commonly available with quoted dewpoints of +3°C, +7°C or +10°C, however care must be taken when selecting this type of dryer as unlike adsorption dryers, the dewpoint quoted is not always provided constantly. Integrated dewpoint meters are typically just temperature gauges and do not indicate a true pressure dewpoint, which is often in the range of 8°C to 15°C.

Other Gaseous Contaminants of Concern

Sulphur Dioxide (SO₂)

Sulphur Dioxide is produced as a by-product of the burning of fossil fuels and is also present in the ambient air drawn into the compressor intake. The oil in an oil lubricated compressor also provides additional benefits as it can also neutralise sulphur dioxide (SO₂) drawn in through the compressor intake.

In an oil free compressor there is no oil to neutralise harmful vapours such as SO₂. As the intercooler and aftercooler in an oil-free compressor condenses water vapour into liquid water, the SO₂ from the air reacts with condensed water vapour to form sulphurous acid (like acid rain). Measurements from compressed air systems show that the resulting condensate has a pH value between 3 and 6 attacking the downstream air receivers, piping and purification equipment more aggressively than condensate from a lubricated compressor.

Atmospheric Pollutants

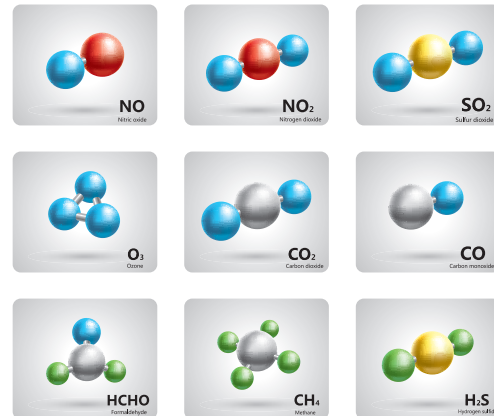

Ozone

Another factor to consider is ozone. Oil-free screw compressors, whilst using oil to lubricate bearings and gearboxes, do not inject oil into the compression stage for cooling. This means the temperature during compression becomes extremely high (above the safe operating temperature of many materials), therefore they typically compress in two stages, unlike an oil lubricated machine which does it in a single stage. An intercooler is placed between the first and second stages to help reduce the temperature, however the compressed air temperature can be in the range of 180°C - 200°C (on oil lubricated screw machines, the compressed air temperature is typically around 80°C).

Formation of Ozone

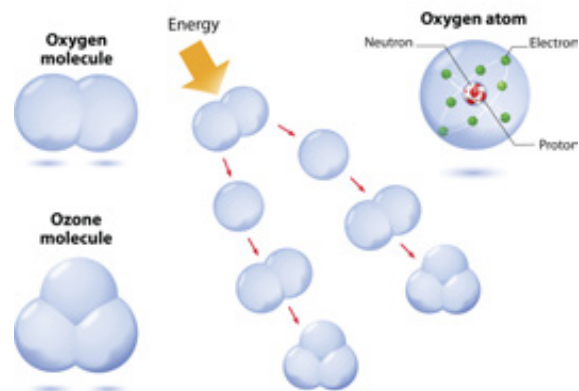

The compression process, its associated high temperature, oxygen and the presence of VOC can create ozone which preferentially and sacrificially attacks certain organic functional groups. Without oil being present in the gas stream, such as in the oil-free machine, it is difficult for the ozone to react and its concentration to reduce and therefore ozone levels in the compressed air discharged by an oil free compressor are likely remain significantly higher than those in an oil lubricated system. The ozone therefore enters the distribution piping downstream of the compressor, often damaging seals, gaskets, valves and purification equipment.

Large bed, activated carbon adsorption filters used for the reduction of oil vapour have the advantage of not only reducing the levels of oil vapour in the compressed air, they will also reduce ozone levels too.

Summary

- Ambient air may look clean but is not
- Ambient air is not 'oil free'
- In addition to water vapour, ambient air contains Hydrocarbons, Volatile Organic Compounds and other gaseous contaminants such as NO_x, SO_x, CO, CO₂. (see Appendix 3 for further information on contaminants and sources)
- Ambient air contains oil vapour, with typical levels between 0.05 mg/m³ & 0.5 mg/m³ (this can be higher in places)
- Air quality reports from DEFRA and other global testing corroborates this
- These compounds are drawn into the compressor intake
- As the ambient air is compressed, the Hydrocarbons, VOC and other contaminants are concentrated
- As the ambient air is not "oil free", oil-free compressors are unable deliver "oil-free" air without the addition of downstream filtration for the reduction of liquid oil, oil aerosols and oil vapour
- Many Oil-free compressors still use oil for lubrication of bearings & gearboxes
- This oil can also pass into the flow of compressed air from damaged seals and from vapours released by the crank case breather as the compressor operates
- The practice of omitting filtration on the belief that an oil-free compressor is delivering oil free air is incorrect
- The purification equipment required downstream of an oil-free compressor is identical to that of an oil lubricated compressor
- To accurately test for oil in a compressed air system the methodology and equipment shown in ISO8573 Parts 2 (oil aerosol) and Part 5 (oil vapour) should be used

Parker Worldwide

Europe, Middle East, Africa

AE – United Arab Emirates,
Dubai

Tel: +971 4 8127100
parker.me@parker.com

AT – Austria, Wiener Neustadt

Tel: +43 (0)2622 23501-0
parker.austria@parker.com

AT – Eastern Europe, Wiener
Neustadt

Tel: +43 (0)2622 23501 900
parker.easteurope@parker.com

AZ – Azerbaijan, Baku

Tel: +994 50 2233 458
parker.azerbaijan@parker.com

BE/LU – Belgium, Nivelles

Tel: +32 (0)67 280 900
parker.belgium@parker.com

BG – Bulgaria, Sofia

Tel: +359 2 980 1344
parker.bulgaria@parker.com

BY – Belarus, Minsk

Tel: +48 (0)22 573 24 00
parker.poland@parker.com

CH – Switzerland, Etoy

Tel: +41 (0)21 821 87 00
parker.switzerland@parker.com

CZ – Czech Republic, Klecany

Tel: +420 284 083 111
parker.czechrepublic@parker.com

DE – Germany, Kaarst

Tel: +49 (0)2131 4016 0
parker.germany@parker.com

DK – Denmark, Ballerup

Tel: +45 43 56 04 00
parker.denmark@parker.com

ES – Spain, Madrid

Tel: +34 902 330 001
parker.spain@parker.com

FI – Finland, Vantaa

Tel: +358 (0)20 753 2500
parker.finland@parker.com

FR – France, Contamine s/Arve

Tel: +33 (0)4 50 25 80 25
parker.france@parker.com

GR – Greece, Piraeus

Tel: +30 210 933 6450
parker.greece@parker.com

HU – Hungary, Budaörs

Tel: +36 23 885 470
parker.hungary@parker.com

IE – Ireland, Dublin

Tel: +353 (0)1 466 6370
parker.ireland@parker.com

IL – Israel

Tel: +39 02 45 19 21
parker.israel@parker.com

IT – Italy, Corsico (MI)

Tel: +39 02 45 19 21
parker.italy@parker.com

KZ – Kazakhstan, Almaty

Tel: +7 7273 561 000
parker.easteurope@parker.com

NL – The Netherlands, Oldenzaal

Tel: +31 (0)541 585 000
parker.nl@parker.com

NO – Norway, Asker

Tel: +47 66 75 34 00
parker.norway@parker.com

PL – Poland, Warsaw

Tel: +48 (0)22 573 24 00
parker.poland@parker.com

PT – Portugal

Tel: +351 22 999 7360
parker.portugal@parker.com

RO – Romania, Bucharest

Tel: +40 21 252 1382
parker.romania@parker.com

RU – Russia, Moscow

Tel: +7 495 645-2156
parker.russia@parker.com

SE – Sweden, Spånga

Tel: +46 (0)8 59 79 50 00
parker.sweden@parker.com

SK – Slovakia, Banská Bystrica

Tel: +421 484 162 252
parker.slovakia@parker.com

SL – Slovenia, Novo Mesto

Tel: +386 7 337 6650
parker.slovenia@parker.com

TR – Turkey, Istanbul

Tel: +90 216 4997081
parker.turkey@parker.com

UA – Ukraine, Kiev

Tel: +48 (0)22 573 24 00
parker.poland@parker.com

UK – United Kingdom, Warwick

Tel: +44 (0)1926 317 878
parker.uk@parker.com

ZA – South Africa, Kempton Park

Tel: +27 (0)11 961 0700
parker.southafrica@parker.com

North America

CA – Canada, Milton, Ontario

Tel: +1 905 693 3000

US – USA, Cleveland

Tel: +1 216 896 3000

Asia Pacific

AU – Australia, Castle Hill

Tel: +61 (0)2-9634 7777

CN – China, Shanghai

Tel: +86 21 2899 5000

HK – Hong Kong

Tel: +852 2428 8008

IN – India, Mumbai

Tel: +91 22 6513 7081-85

JP – Japan, Tokyo

Tel: +81 (0)3 6408 3901

KR – South Korea, Seoul

Tel: +82 2 559 0400

MY – Malaysia, Shah Alam

Tel: +60 3 7849 0800

NZ – New Zealand, Mt Wellington

Tel: +64 9 574 1744

SG – Singapore

Tel: +65 6887 6300

TH – Thailand, Bangkok

Tel: +662 186 7000

TW – Taiwan, Taipei

Tel: +886 2 2298 8987

South America

AR – Argentina, Buenos Aires

Tel: +54 3327 44 4129

BR – Brazil, Sao Jose dos Campos

Tel: +55 800 727 5374

CL – Chile, Santiago

Tel: +56 2 623 1216

MX – Mexico, Toluca

Tel: +52 72 2275 4200



EMEA Product Information Centre

Free phone: 00 800 27 27 5374

(from AT, BE, CH, CZ, DE, DK, EE, ES, FI, FR, IE, IL,
IS, IT, LU, MT, NL, NO, PL, PT, RU, SE, SK, UK, ZA)

US Product Information Centre

Toll-free number: 1-800-27 27 537

www.parker.com/gsf