

| PARTS LIST | | | | | |
|------------|-----------------------------|------------|---------|--------------------------|-----|
| NO. | DESCRIPTION | PART NO. | DWG NO. | MATL | QTY |
| 1 | HEAD ASSEMBLY | 15011 | B-16416 | SST. | 1 |
| 2 | HEAD | 15011-1 | C-16414 | ASTM A-351 GR. CF8M SST. | * |
| 3 | STUD | 15010-2 | A-12433 | ASTM A-479 TYPE 316 SST. | * |
| 4 | BOWL ASSEMBLY | C01-0062 | B-18560 | 316 SST. | 1 |
| 5 | BOWL | C01-0061 | C-18558 | 316 SST. | ** |
| 6 | COLLAR | 15152 | C-16413 | ASTM A-479 TYPE 316 SST. | ** |
| 7 | NUT | A02-0020 | A-17290 | ASTM A-479 TYPE 316 SST. | 4 |
| 8 | WASHER, FLAT, 1/2" (TYPE N) | A02-0028 | A-17291 | ASTM A-479 TYPE 316 SST. | 4 |
| 9 | TIEROD | 15080 | B-14022 | SST. | 1 |
| 10 | LOCK NUT | 12707 | A-11321 | SST. | 1 |
| 11 | HEAD ADAPTER | 15407 | C-16412 | 316 SST. | 1 |
| 12 | O-RING (-032) | 22035-1 | ----- | VITON | 1 |
| 13 | O-RING (-347) | 22146-1 | ----- | VITON | 1 |
| 14 | FILTER TUBE | 200-80-[] | ----- | --- | --- |
| 15 | 1/4" NPT PIPE PLUG | 11925 | A-11319 | 316 SST. | 1 |
| 16 | GROMMET/RETAINER ASSEMBLY | 19938-1 | A-12034 | SST./VITON | 1 |
| 17 | SUPPORT CORE | SS-200-81 | B-10818 | SST. | --- |
| 18 | KNOB | 19918 | A-10732 | 316 SST. | 1 |
| 19 | THREAD PROTECTOR | 21206 | A-11862 | PLASTIC | 2 |

LEGEND

☒ = REPLACEABLE PARTS

⊕ = OPTIONAL PARTS

* = INCLUDED IN AUTOMATIC DRAIN

** = INCLUDED IN BOWL ASSEMBLY

| REVISIONS | | | | |
|-----------|---------|-----------------|------|-------|
| REV | ECN.NO. | DESCRIPTION | NAME | DATE |
| A | 0815 | REVISED PER ECN | S.D | 8/97 |
| B | 0832 | REVISED PER ECN | EHS | 10/97 |
| C | 0845 | REVISED PER ECN | EHS | 1/98 |
| D | 0939 | REVISED PER ECN | EHS | 8/99 |
| E | 1124 | REVISED PER ECN | PES | 4/02 |
| F | 1208 | REVISED PER ECN | EHS | 02/03 |
| G | 1612 | REVISED PER ECN | HS | 12/06 |
| H | 1833 | REVISED PER ECN | HS | 01/10 |
| J | 2253 | REVISED PER ECN | HS | 10/12 |

SEE NOTE 2.

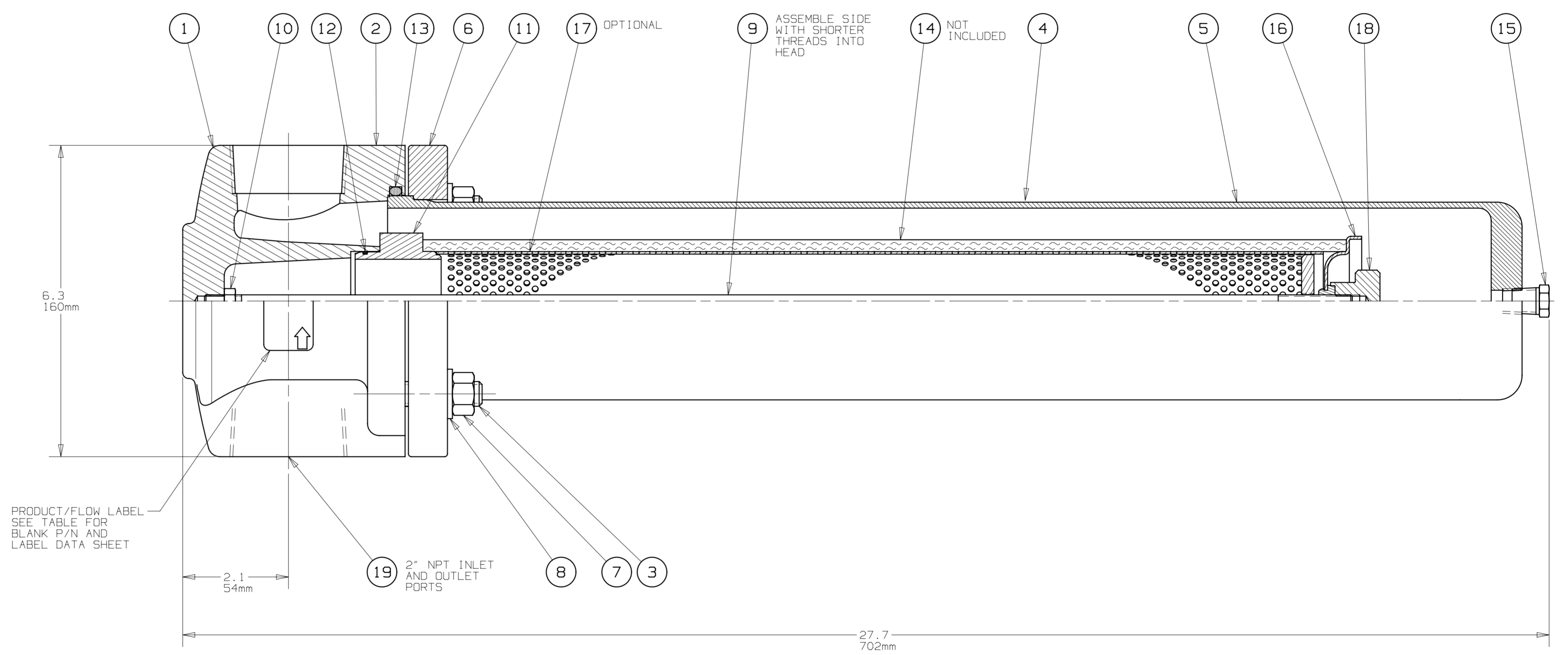
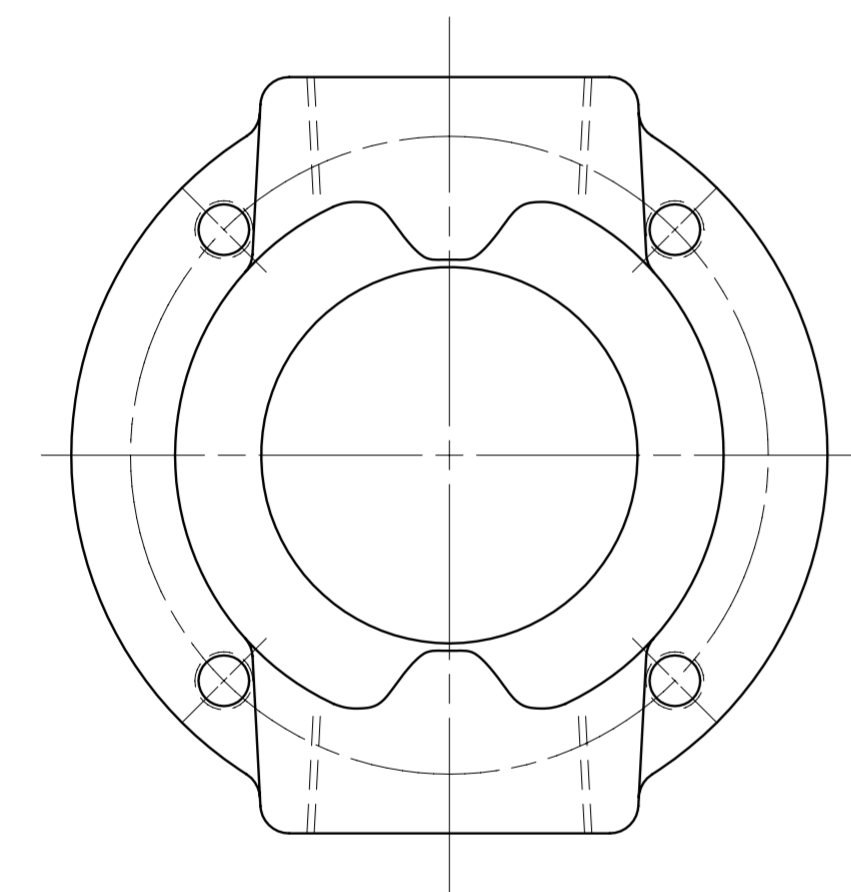

- NOTES:
- ALL ASSEMBLY AND PACKAGING MUST BE PERFORMED IN ACCORDANCE WITH THE APPROPRIATE MANUFACTURING METHOD SHEET SPECIFIED FOR THIS ASSEMBLY.
 - ALL O-RINGS TO BE LUBRICATED WITH APPROVED LUBRICANT ONLY.
 - ALL HOUSINGS TO BE SHIPPED WITH PLASTIC THREAD PROTECTORS (ITEM 19) INSTALLED.
 - PRESSURE RATING: 800 psig(55 bar) AT 200° F.(93°C.).
 - DESIGNED IAW ASME VIII DIV. 1 2010 ED. 2011e ADD MDMT: -20F HYDROTEST PRESSURE: 1200 PSIG. CORROSION ALLOWENCE: 0 NDE: NONE IMPACT TEST EXEMPT PER UHA-51(d) PWHT:NONE

| REPLACEMENT SEAL SETS | | | |
|-----------------------|---------------|-------------|-----|
| SEAL SET NUMBER | MAT'L | CONSISTS OF | |
| | | NO | QTY |
| 22146 | VITON | 12 | 1 |
| | | 13 | 1 |
| 19938 | VITON/S.S. | 16 | 1 |
| | | 13 | 1 |
| 22144 | SILICONE | 12 | 1 |
| | | 13 | 1 |
| 19942 | SILICONE/S.S. | 16 | 1 |
| | | 13 | 1 |
| 22145 | EPR | 12 | 1 |
| | | 13 | 1 |
| 19943 | EPR/S.S. | 16 | 1 |

| | | | |
|--------------------|--------------|-------------|--------------|
| EU15/80S6 | AS PACKAGED | A04-0073 | LDSEU15/80S6 |
| 15/80S6 | AS PACKAGED | 11138 | LDS15/80S6 |
| 42285 | AS ASSEMBLED | NO LABELING | NO LABELING |
| PART NO. | DESCRIPTION | BLANK P/N | DATA SHEET |
| PRODUCT/FLOW LABEL | | | |

| | | | | | |
|---|--|--------------------------------|----------------|---|--|
| THIRD ANGLE PROJECTION <small>THIS DOCUMENT CONTAINS INFORMATION THAT IS CONFIDENTIAL AND PROPRIETARY TO PARKER FILTRATION AND SEPARATION DIVISION ("PARKER"). THIS DOCUMENT IS FURNISHED ON THE UNDERSTANDING THAT THE DOCUMENT AND THE INFORMATION IT CONTAINS WILL NOT BE COPIED OR DISCLOSED TO OTHERS OR USED FOR ANY PURPOSE OTHER THAN CONDUCTING BUSINESS WITH PARKER, AND WILL BE RETURNED AND ALL FURTHER USE DISCONTINUED UPON REQUEST BY PARKER. COPYRIGHT PARKER, YEAR OF COPYRIGHT IS FIRST YEAR INDICATED ON THIS DOCUMENT. ALL RIGHTS RESERVED.</small> | TOLERANCES EXCEPT AS NOTED .XX X.Xmm ±.015 .XX X.Xmm ±.38mm .XXX XX.XXmm ±.005 .XXX XX.XXmm ±.13mm ANGULAR ±1° SURFACE ROUGHNESS OR BETTER REMOVE ALL BURRS AND SHARP EDGES. | ENG. APVD.: CH'KD BY: | DATE: DATE: | Parker Hannifin Corporation <small>Filtration and Separation Division Haverhill, Massachusetts USA</small> | |
| | | DRAWN BY: PES DATE: 5/31/97 | | | TITLE: FILTER ASSEMBLY |
| | | SEE PARTS LIST | | | FINISH: MODEL NO.: SEE TABLE |
| | | P/N: SEE TABLE | | | SCALE: .625 : 1 SHEET: 1 OF 1 |

DWG. NO.: D-16418