

**General Description**

Series SE2E features electronic spool position feedback and on-board electronics. Spool position feedback can be used as a safety monitoring tool, or for minimizing valve hysteresis. The SE2E is a two stage, 4-way, flapper and nozzle style servovalve.

A special jewel feedback design enhances durability and prevents ball glitch problems, which can occur in other types of servovalves. This valve is rated for 315 Bar (4500 PSI) service.

**Features**

- On-board electronics
- Electronic spool position feedback
- Jewel feedback ball for durability
- High performance
- ISO 10372 standard 22.23 mm (0.875 in.) port circle

**Specifications**

<b>Flow Rating ±10% @ 70 Bar (1000 PSI)</b>	3.8, 9.5, 19, 38, 63, 75 LPM (1, 2.5, 5, 10, 16.5, 20 GPM)
<b>Supply Pressure</b>	10 – 315 Bar (145 – 4500 PSI)
<b>Tank Port Pressure</b>	210 Bar (3000 PSI) Max. < 10 Bar (145 PSI) for best performance
<b>Null Leakage Flow per 70 Bar (1000 PSI)</b>	1.2 – 1.9 LPM (0.3 – 0.5 GPM)
<b>Pilot Flow @ 210 Bar (3000 PSI)</b>	0.4 – 0.8 LPM (0.1 – 0.2 GPM)
<b>Input Command</b>	±10 V std.
<b>Frequency Response @ 90° phase shift</b>	≥ 300 Hz (See Performance Curves)
<b>Non-Linearity</b>	≤ 5%
<b>Hysteresis</b>	≤ 0.5%
<b>Threshold</b>	≤ 0.1%
<b>Null Shift with temperature with pressure</b>	≤ 1% per 55°C (100°F) ≤ 1% per 70 Bar (1000 PSI)
<b>Pressure Gain change in pressure per 1% change in input command</b>	80% typical
<b>Step Response</b>	0 - 100%, 4 to 9 ms
<b>Fluid</b>	Petroleum based Mineral Oil, 10 – 110 cSt at 38°C (100°F)
<b>Fluid Cleanliness</b>	ISO 4406 15/12 or better
<b>Operating Temperature</b>	-20°C to +85°C (-4°F to +185°F)
<b>Protection Class</b>	NEMA 4, IP65

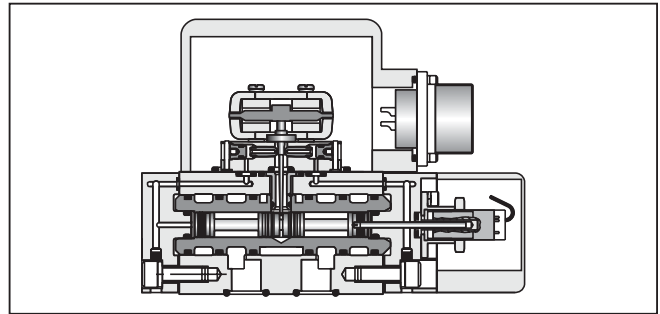
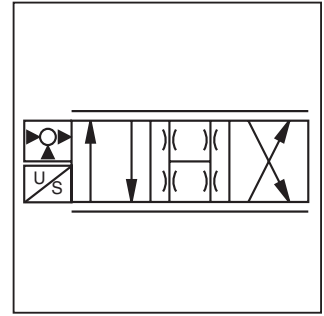
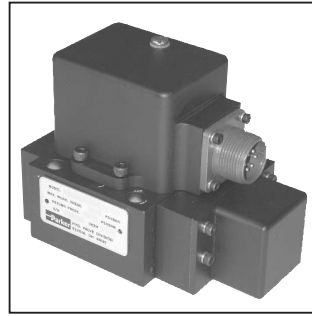

**C**

**Flow vs. Pressure Drop**

at 100% command  
Flow Path P → C1 → C2 → R

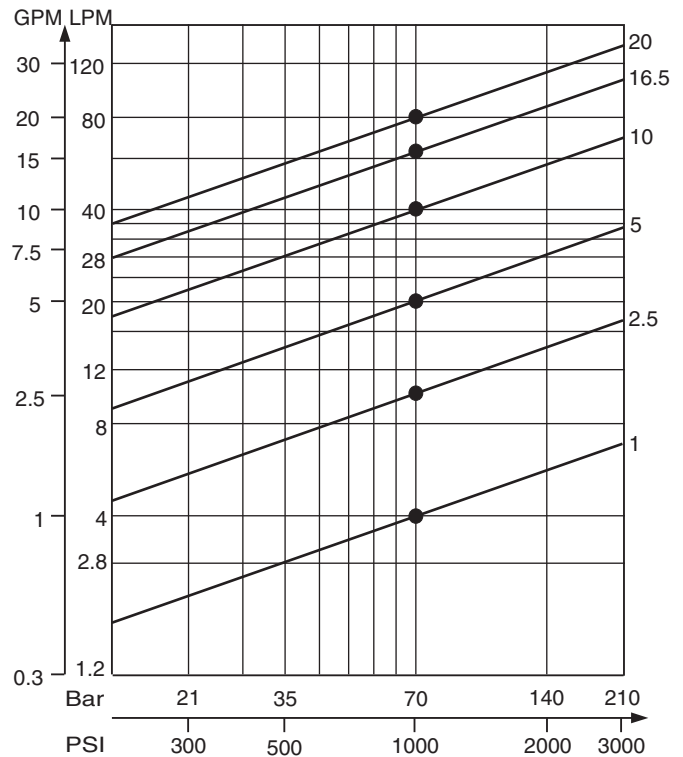

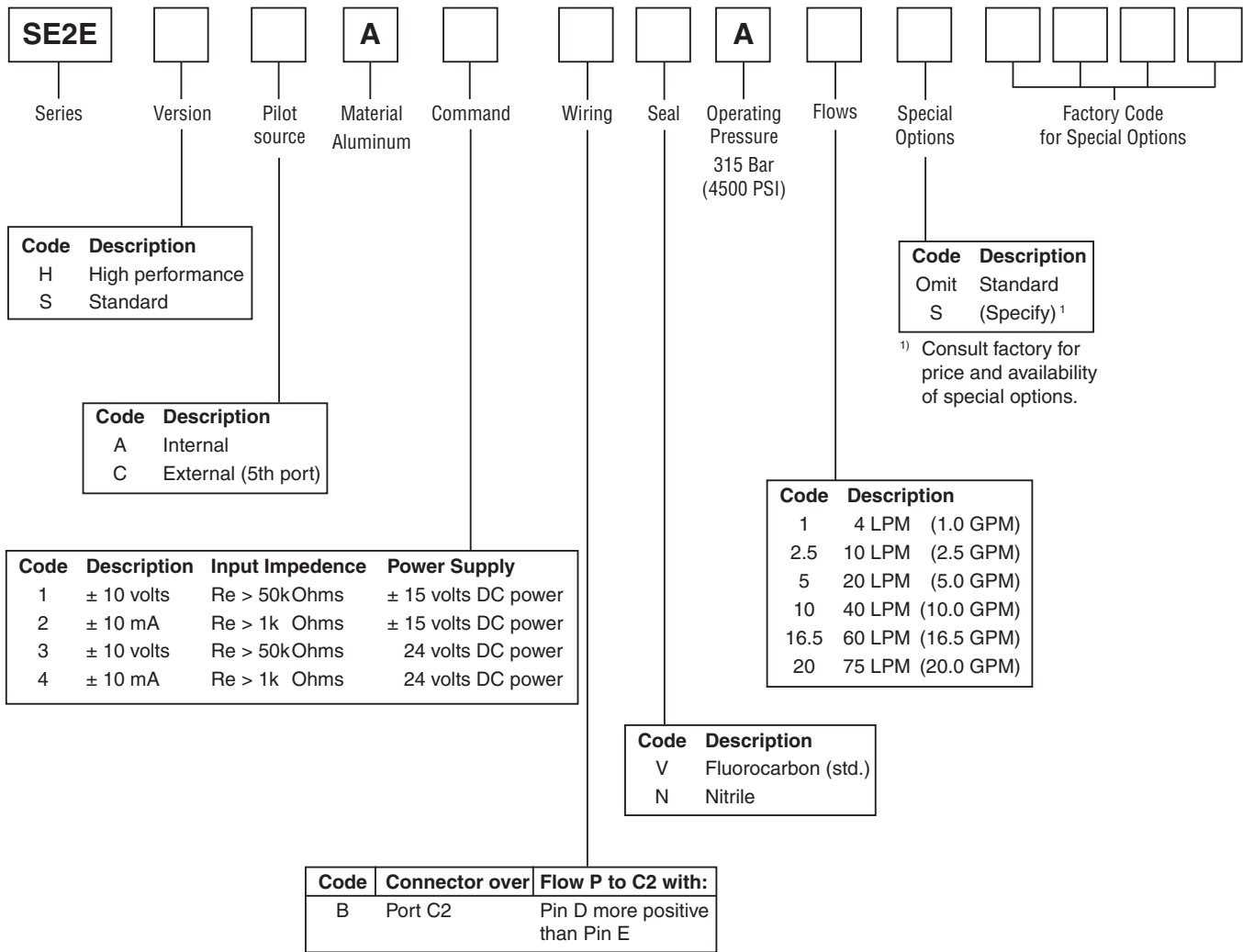

**Weight:** 1.5 kg (3.3 lbs.)  
**Cable with mating connector:** EHC158GE  
**Mating connector:** 5004072 (a 7-pin metal CE connector)  
**Bolt kit:** 4 of M8 x 60 mm, or 4 of 5/16-18x2.25"  
**Flushing valve:** 1200127 (does not cover 5<sup>th</sup> port)  
**U.S. Subplate, 5 ports:** 1402303 (4) #12 SAE side ports, (1) #4 SAE side ports  
**U.S. Subplate, 4 ports:** 810090-3 (4) #12 SAE side ports  
**Metric Subplate, 4 ports:** DS04SPS12M (M27 x 2.0 ISO 6149 side ports)  
**Electronics:** BD101, 23-7030, BD90, or BD95

**Frequency Response at 210 Bar (3000 PSI)**

**Standard Response**  
**SE2E – 20 LPM (5 GPM)**

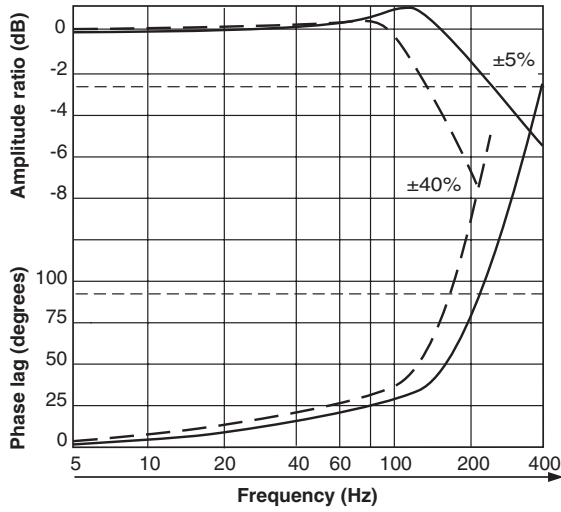

**High Response**  
**SE2E – 4 - 40 LPM (1.0 - 10 GPM)**

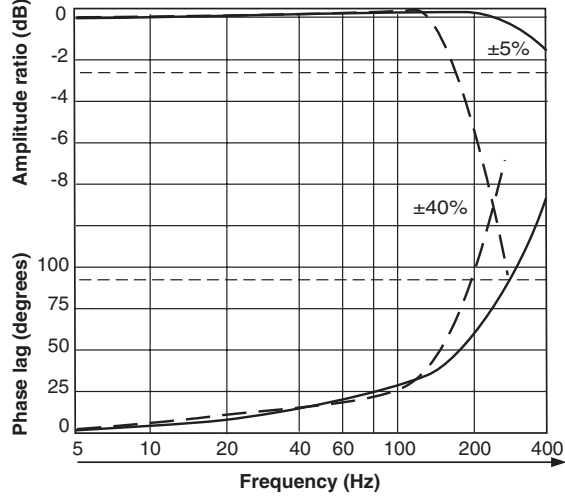

**Standard Response**  
**SE2E – 75 LPM (20 GPM)**

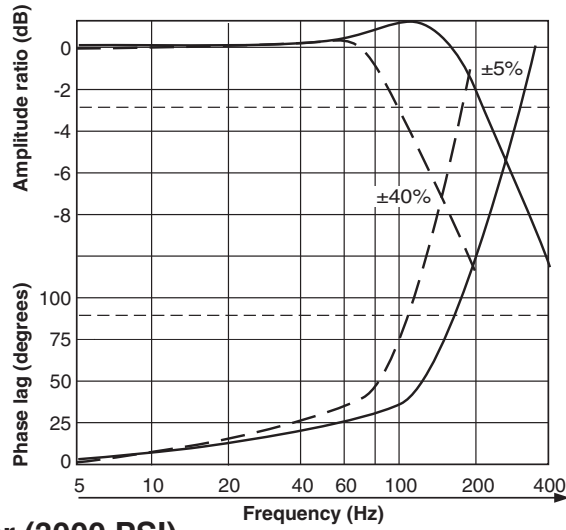

**Step Response at 210 Bar (3000 PSI)**

**Standard Response**

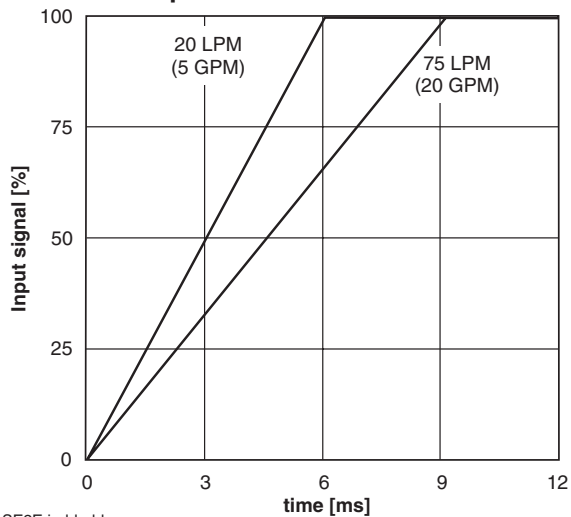

**High Response**

**SE2E – 4 - 40 LPM (1.0 - 10 GPM)**

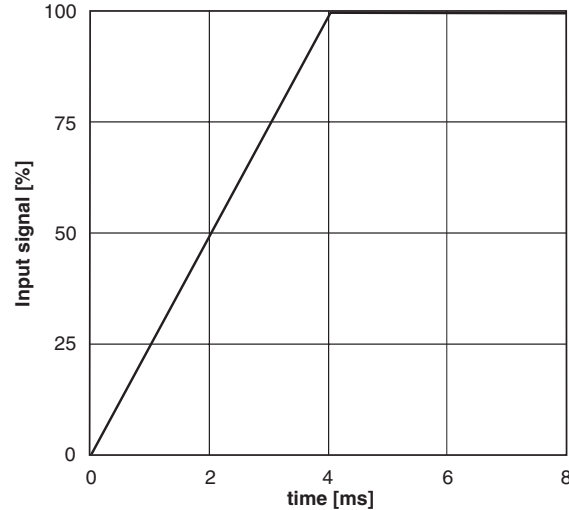

SE2E.indd, ddp



Inch equivalents for millimeter dimensions are shown in (\*\*)



**C**

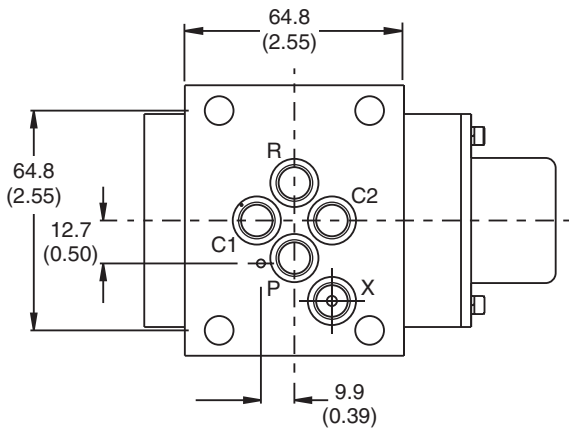
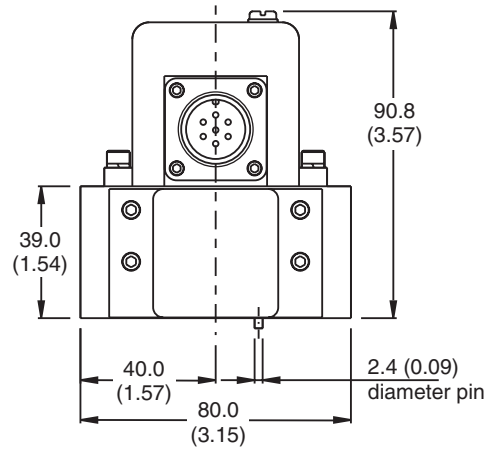
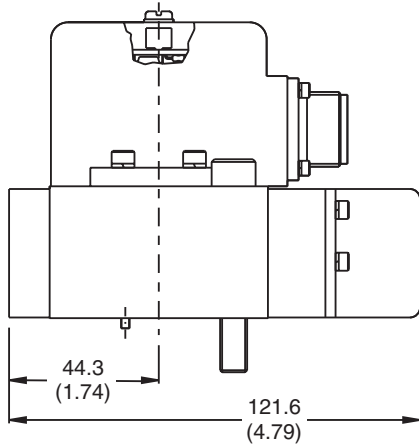

1. Suggested mounting bolts M8 x 60 mm or 5/16-18 x 2.25" long high tensile steel, socket-head cap screws.
2. The 7-pin electrical connector mates with Parker 5004072 connector or equivalent. The connector is available at 180° to position shown (advise desired position at time of order).
3. Base O-Rings: 10.82 I/D x 1.78 section (2013N-9 or 2013V-9) 5 pcs.
4. Null adjustment potentiometer.

**Mounting Surface**

1. The minimum depth of hole G is 2 mm (0.079 in.). The ISO recommended full-thread depth is 22 mm (0.866 in.).
2. Surface roughness Ra < 0.8 μm [N6], as specified in ISO 468 and ISO 1302.
3. Surface flatness: 0.025 mm (0.001 in.) as specified in ISO 1101.

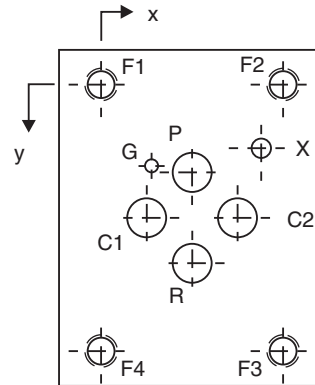



Metric Dimensions (mm)						(± 0.1 mm)				
Axis	P	C1	R	C2	G	X	F1	F2	F3	F4
	Ø 8.2 max	Ø 8.2 max	Ø 8.2 max	Ø 8.2 max	Ø 3.5	Ø 5	M8	M8	M8	M8
x	22.2	11.1	22.2	33.3	12.3	33.3	0	44.4	44.4	0
y	21.4	32.5	43.6	32.5	19.8	8.7	0	0	65.0	65.0



U.S. Dimensions (inches)						(± 0.004 in.)				
Axis	P	C1	R	C2	G	X	F1	F2	F3	F4
	Ø 0.32 max.	Ø 0.32 max.	Ø 0.32 max.	Ø 0.32 max.	Ø 0.14 max.	Ø 0.2	5/16 - 18	5/16 - 18	5/16 - 18	5/16 - 18
x	0.875	0.437	0.875	1.311	0.484	1.310	0	1.750	1.750	0
y	0.846	1.280	1.717	1.280	0.780	0.343	0	0	2.562	2.562

SE2E.indd, ddp



	Pin	Voltage Command	Current Command
Supply voltage +15/0/-15 VDC ±3%  Ripple < 50 mV <sub>p-p</sub>	A	+15 VDC  $I_{max} = 200 \text{ mA}$	
	B	-15 VDC  $I_{max} = 200 \text{ mA}$	
	C		
Command signal   R <sub>e</sub>	D	0...±10 VDC  $R_e \geq 50 \text{ k}\Omega$	0...±10 mA  $R_e \geq 1 \text{ k}\Omega$
	E		
Spool position output	F	0...±10 VDC  load resistance 10 kΩ	0...±10 VDC  load resistance 10 kΩ
Protective Earth	G		



	Pin	Voltage Command	Current Command
Supply voltage +24 VDC ±3%  Ripple < 50 mV <sub>p-p</sub>	A	+24 VDC  $I_{max} = 200 \text{ mA}$	
	B		
	C	Not used	
Command signal   R <sub>e</sub>	D	0...±10 VDC  $R_e \geq 50 \text{ k}\Omega$	0...±10 mA  $R_e \geq 1 \text{ k}\Omega$
	E		
Spool position output	F	0...±10 VDC  load resistance 10 kΩ	0...±10 VDC  load resistance 10 kΩ
Protective Earth	G		

Spool stroke is proportional to command signal.  
 +10 VDC to pin D causes 100% rated flow in the direction  
 of P→C2, C1→R.

One input D or E must be connected to common if a single  
 ended driver is used.

Connection cable to be 6-core, 0.75 mm<sup>2</sup> (0.03 in<sup>2</sup>), screened.  
 External diameter 6.5~9.5 mm (0.26 - 0.37 in.).  
 Connect screening to  on supply side only.

Mating connector is Parker number 5004072.  
 A mating cable with connector is Parker number EHC158GE.

