

Parker Sealing Technology

Provides Unmatched Leak Protection on all Industrial Hydraulic and Pneumatic Cylinders



One of the leading causes of **cylinder failure** is **seal failure**. Parker offers sealing options that cover the widest assortment of applications in the market, ensuring you can get the right seal for your job. The following bulletin will look at Parker cylinders by series and their sealing options to better assist in your specification of sealing requirements.

2H Piston Seal Types:

One of Parker's core cylinder series, the 2H is a 3000 psi NFFPA tie rod hydraulic cylinder available in 1.50"-6.00" bore diameters and up to 240" stroke length. The 2H series piston seal kits utilize Parker's new universal piston seal design, which addresses the performance balance between low pressure sealability, low friction, extrusion resistance and seal life. One piston style is used for all piston seal and wear ring configurations and will suit all application requirements. This reduces the complexity in maintaining cylinders, saving time and cost.

Parker offers **4 unique seal types**, as shown in the chart below, that when paired with the right seal class will provide the right sealing for your application. Seal class types are located on page 4.

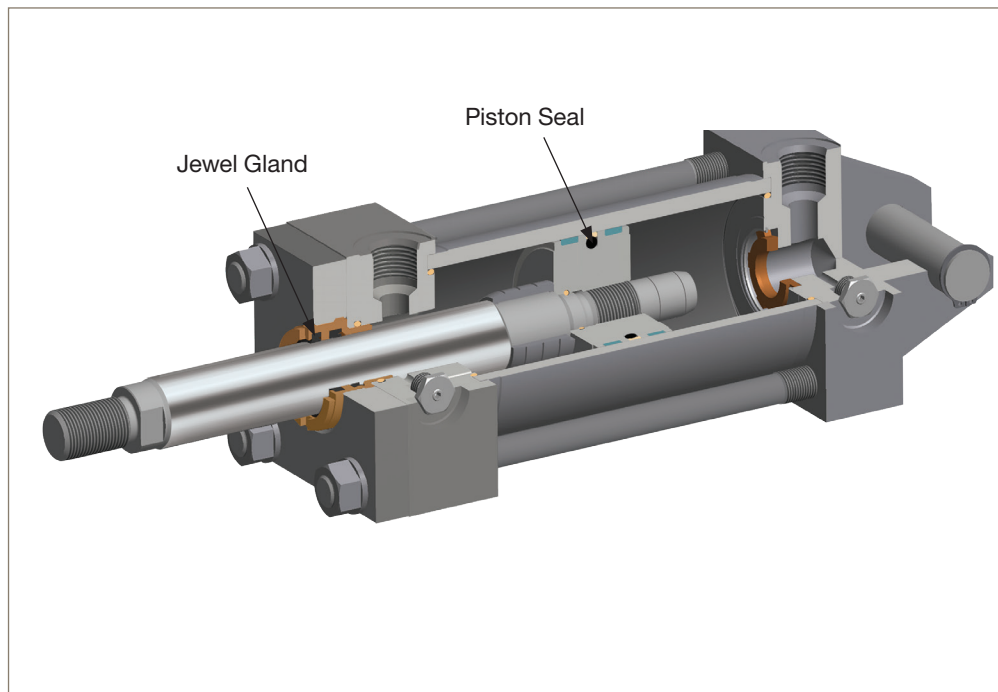

Contact Information:

Parker Hannifin Corporation
Cylinder Division
 500 South Wolf Road
 Des Plaines, IL 60016

phone 847-298-2400
 cyltech@parker.com

www.parker.com/cylinder



Seal Features:

Application Demand	HP Seal	KP Seal	RP Seal	WP Seal
Load Holding	Best	Good	Good	Best
Fluid Compatibility	Good	Best	Better	Better
Heat Resistance	Good (200° F Max.)	Best (400° F Max.)	Better (300° F Max.)	Better (250° F Max.)
Dynamic Friction	Best	Best	Good	Better
Breakaway Friction	Good	Best	Good	Better
Extrusion Resistance	Good	Better	Best	Good
Fluid Isolation	N/A	N/A	N/A	Best
Compatible Seal Classes	1 and 4	1,2,3,4, 5,6 and 8	1,2,3,4, 5 and 6	1,2,3,4, 5 and 6

HP - Polyurethane Piston Seal

KP - Filled PTFE Piston Seal

RP - Thermoplastic Seal

WP - Mixed Media Seal

ENGINEERING YOUR SUCCESS.

2H Rod Sealing System:

Parker's **TS2000 threaded Jewel Gland** sealing system acts as an automatic check valve that prevents any appreciable amount of oil to leak past the seals.

As the rod strokes out, the TS2000's multi-sealing edges maintain contact with the rod. This provides a cutting action to shear oil from the rod, allowing the rod to pass out of the rod seal practically dry. Any oil that remains on the rod is stopped by the inner lip of the Wiper-seal and held between it and the rod seal. On the return stroke any dirt collected on the rod is wiped off by the outer lip of the Wiper-seal. At the same time, any oil trapped between the Wiper-seal and the rod seal is returned into the cylinder. The TS2000 Jewel Gland is easily removed for service without loosening tie rods and disturbing the pressure envelope.

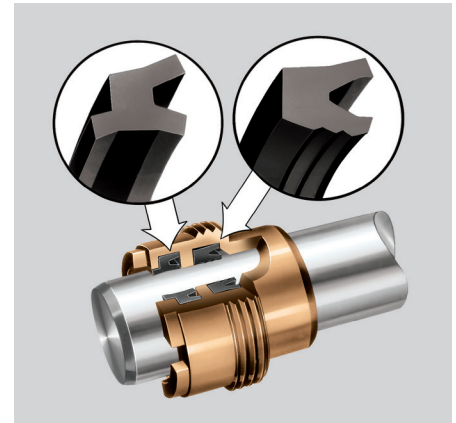

Additional 2H Sealing Options:

For environments that contain fine abrasive particulates Parker recommends the **Parker Crown Wiper™** for Series 2HD. The 3000 psi NFPA tie rod hydraulic 2HD cylinder is the next step up in Parker's 2H line for applications that require increased durability and is also available in 1.50"-6.00" bore diameters and up to 240" stroke length.

The Crown Wiper is a proven superior alternative to piston rod end boots or metallic wipers that can ingest particulate. It has a sharp leading edge to effectively clean the piston rod and a beveled shape to prevent contaminant intrusion by channeling it away from the gland. It also acts as a secondary seal to wipe clean any oil film adhering to the rod on the extend stroke. Standard Crown Wiper material for Seal Class 1 and 2 service is durable polyurethane. Optional FKM material is available for Class 5 service.

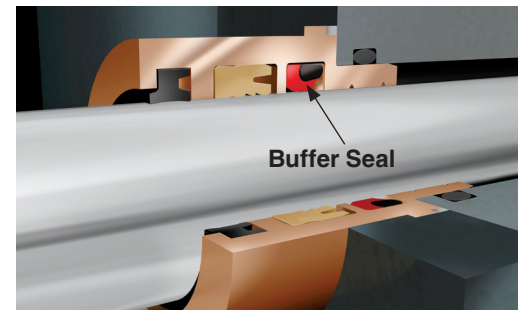

The Parker Buffer Seal, installed ahead of the primary rod seal, protects the primary seal from the effects of pressure spikes. The result is increased primary rod seal and wiper seal performance life when in severe applications. Both seals provide superior protection against harmful contamination that can damage cylinders causing unnecessary downtime. Buffer Seals are available in class 1, 2, 3, 4, 5 and 6.

Sealing for RDH:

Parker's heavy-duty hydraulic round-line cylinder series, the RDH is a 3000 psi cylinder available in 1.50"-8.00" bore diameters and up to 240" stroke length. The RDH offers a **Tri-Lip Rod Seal** and **Bi-Directional Piston Seal** with proven leak-free performance. Durable polyurethane material is used to maximize seal life. Nitrile end seals and backup rings on a smooth bore of the cylinder body provide optimal sealing and elimination of extrusion problems. Composite rod and piston wear rings are internally lubricated for reduced friction and formulated for heavy-duty, load-bearing applications. Standard rod material is case-hardened, hard chrome plated and polished to an optimum finish. And since we use Parker seals, all seals have immediate availability in other popular compounds.

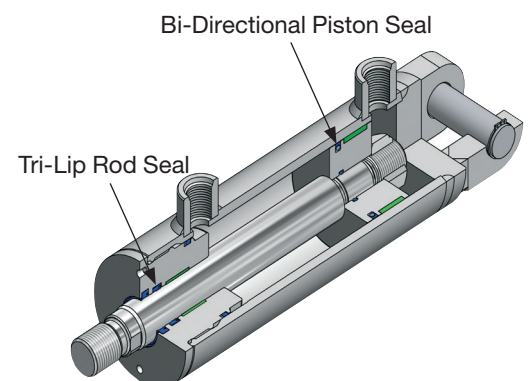

Sealing for 2A/2AN:

Parker's heavy-duty pneumatic cylinder series, the 2A is a 250 psi NFPA tie rod cylinder available in 1"-14" bore diameters and up to 240" stroke length. The 2A provides a serrated lip-seal in its rod gland that has a series of sealing edges which take over successively as pressure increases, providing efficient sealing under all operating conditions. The double lip wiper-seal acts as a secondary seal, cleaning the rod on the return stroke. Its outer lip prevents the ingress of dirt into the cylinder, extending the life of the gland and seals, minimizing costly replacements.

Parker Series 2AN, the **non-lubricated** version of the 2A, and comes with Non-Lubricated Rod Seals. These seals with special rounded sealing lips are supplied as standard for all non-lubricated applications and provide all the same benefits as the 2A rod seal

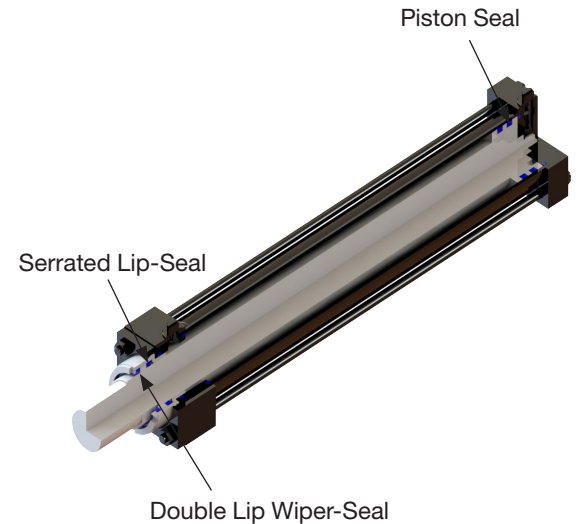

CHE/CHD Seal Design:

Parker offers two compact hydraulic cylinders, the 140 bar aluminum CHE with up to 150mm stroke length and the 207 bar steel CHD with up to 100mm stroke length, both are available in 20mm to 100mm bore diameters. These compact cylinders include 4 key elements to keep your cylinder leak free:

1. **Primary Seal** – polyurethane rod seal with multiple sealing edges is self-compensating and self-relieving to withstand pressure variations and conform to mechanical deflection that may occur.
2. **Secondary Seal (Rod Wiper)** – wipes clean any oil film adhering to the rod on the extend stroke and cleans the rod on the return stroke.
3. **Bi-Directional Piston Seal** – Polyurethane seal ring with energizer provides leak-free performance.
4. **Non-Metallic Wear Band** – improves resistance to bearing loads

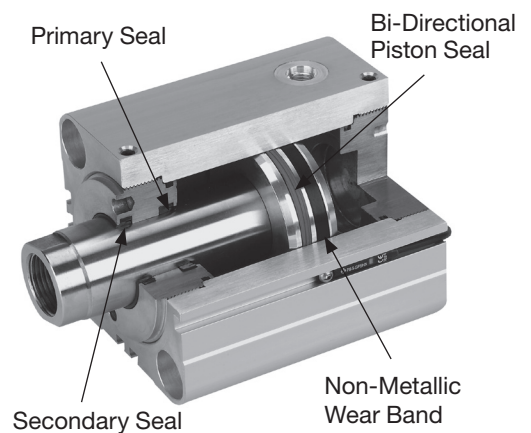

Sealing for 3L:

For use in applications that require lighter duty than the 2H, Parker's 3L series is a 1000 psi NFPA tie rod hydraulic cylinder available in 1.00"-8.00" bore diameters and up to 240" stroke length. The 3L's **Piston Lip-seals** provide zero leakage under static conditions. Seals are self-compensating to conform to variations in pressure, mechanical deflection, and wear, and have back-up washers to prevent extrusion.

The 3L Series also utilizes the **TS2000 Rod Seal System** with its proven leakproof design. It is completely self-compensating and self-relieving to withstand variations and conform to mechanical deflection that may occur. All these features result in a cylinder seal that will withstand the rigors of your applications reducing maintenance costs.

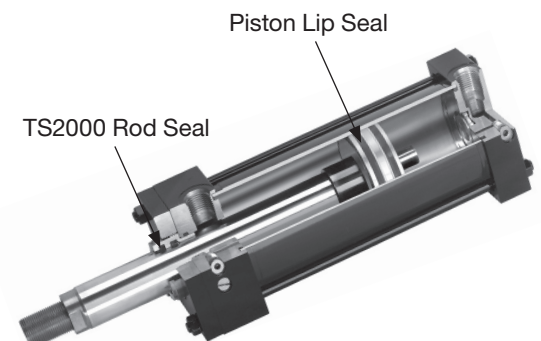

Seal Classes:

It is important to choose the right seal for the right job to prevent deterioration from **fluid incompatibility** or **premature wear**. Parker's years of experience in fluid power has provided invaluable expertise in sealing technology. This expertise provides our customers with the knowledge to pick the right seal class and minimize costly replacements.

Two main factors in choosing the right seal are **fluid type and temperature**. The chart below is a quick guide to which class of seal to use in your application:



Class No.	Typical Fluids	Temperature Range	Common Applications
1. Nitrile or Polyurethane Seal	Air, Nitrogen, Hydraulic Oil, Mil-H-5606 Oil	-10°F (-23°C) to +165°F (+74°C)	Most Industrial
2. Water Base Fluid Seal (for Water-Glycol solution w/ less than 20% Water Concentration)	Water, Water-Glycol, Water-in-Oil Emulsion, Houghto-Safe 620, Mobil Pyrogard D	-10°F (-23°C) to +165°F (+74°C)	Water based systems, Auto-manufacturing
3. EPR (ethylene-propylene) Seal*	Some Phosphate Ester Fluids; Skydrol 500, 7000	-10°F (-23°C) to +130°F (+54°C)	Aerospace, Nuclear plants
4. Nitrile Seal	Low Temperature Air or Hydraulic Oil	-50°F (-46°C) to +150°F (+66°C)	Oil production in cold climates
5. Fluorocarbon Seal **	High Temperature Houghto-Safe 1120; Fyrquel 150, 220, 300; Mobil Pyrogard 53	-10°F (-23°C) to +300°F (+149°C)	High temp applications, aerospace, fuel systems
6. HWCF (High Water Content) Fluid Seal	Houghton Hydrolubric 120B, for other HWCF — consult factory.	+40°F (+4°C) to +120°F (+49°C)	Rolling mills and other molten metal applications
8. Energized PTFE	See Class 5 Seals	-15°F (-26°C) to +400°F (+204°C)	Harsh environment applications

*EPR seals are not compatible with hydraulic oil

**Fluorocarbon Seals are not suitable for use with Skydrol fluid, but can be used with hydraulic oil if desired.