

The pilot operated proportional directional valves D\*1FC with position feedback are available in 4 sizes:

- D31FC - NG10 (CETOP 05)
- D41FC - NG16 (CETOP 07)
- D91FC - NG25 (CETOP 08)
- D111FC - NG32 (CETOP 10)

The digital onboard electronics is situated in a robust metal housing, which allows the usage under rough environmental conditions.

The nominal values are factory set. The parametrizing cable to connect to a serial RS232 interface is available as accessory.



D41FC

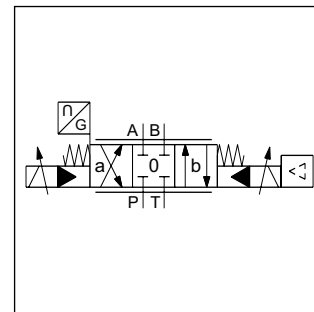

Standard D\*1FC

**3**

**Features**

- Progressive flow characteristics for sensitive adjustment
- Low hysteresis
- High dynamics
- High flow capacity
- Centre position monitoring optional

**D41FC**

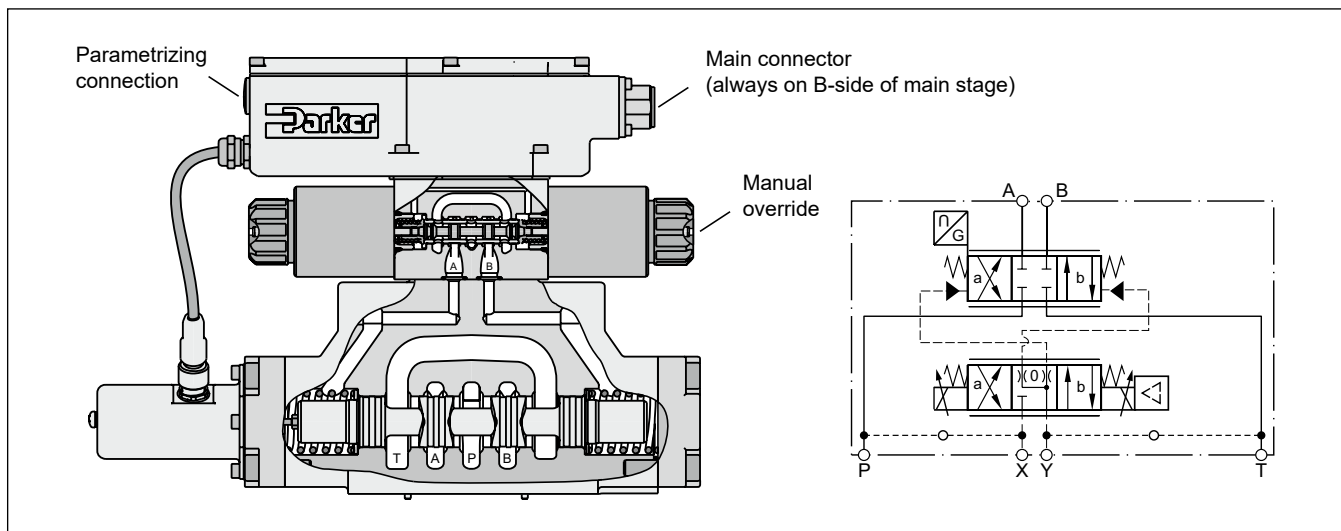

**3**

<b>D</b>		<b>1</b>	<b>F</b>	<b>C</b>			<b>C</b>						
Directional control valve	Size	NG06 pilot	Proportional control	Integrated electronics with position feedback	Function	Flow	Spool position on power down	Pilot connection	Seal	Command signal	Electronic option	Valve option	Design series (not required for ordering)

Code	Nominal size
3	NG10 / CETOP 05
4	NG16 / CETOP 07
9 <sup>1)</sup>	NG25 / CETOP 08
11	NG32 / CETOP 10

Code	Valve option
0	Standard for spool type B, E R
8 <sup>4)</sup>	Monitor switch

Code	Electronic option <sup>2)</sup>
0	6+PE acc. EN175201-804
5	11+PE acc. EN175201-804
7	6+PE + enable acc. EN175201-804

Code	Command signal	Function
B	0...±10 V	0...+10 V P -> B
E	0...±20 mA	0...+20 mA P -> B
K	0...±10 V	0...+10 V P -> A
S	4...20 mA	12...20 mA P -> A

Code	Seal
N	NBR
V	FPM

Code	Inlet	Drain
1	Internal	External
2	External	External
4	Internal	Internal
5	External	Internal

Code	Flow [l/min]			
	at Δp = 5 bar per metering edge			
	D31	D41	D91	D111
D	90	—	—	—
E	120	—	—	—
F	—	200	—	—
H	—	—	450	—
L	—	—	—	1000

Code	Spool type
Overlap	
E01	
E02	
B31	$Q_B = Q_A / 2$ 
B32	$Q_B = Q_A / 2$ 

Short delivery time for all variations

Parametrizing cable OBE<sup>®</sup> RS232, item no. 40982923

<sup>1)</sup> With enlarged connections Ø 32 mm.

<sup>2)</sup> Please order plugs separately, see accessories.

<sup>3)</sup> Please order female connector M12x1 separately (see accessories, female connector M12x1 (order no.: 5004109).

<b>General</b>				
Design	Pilot operated DC valve			
Actuation	Proportional solenoid			
Size	<b>NG10 (CETOP 05)</b> D31	<b>NG16 (CETOP 07)</b> D41	<b>NG25 (CETOP 08)</b> D91	<b>NG32 (CETOP 10)</b> D111
Mounting interface	DIN 24340 / ISO 4401 / CETOP RP121 / NFPA			
Mounting position	unrestricted			
Ambient temperature	[°C] -20...+60			
MTTF <sub>D</sub> value <sup>1)</sup>	[years] 75			
Weight	[kg] 9.0	12.5	21.0	68.5
Vibration resistance	[g] 10 Sinus 5...2000 Hz acc. IEC 68-2-6 10 (RMS) Random noise 20...2000 Hz acc. IEC 68-2-36 15 Shock acc. IEC 68-2-27			
<b>Hydraulic</b>				
Max. operating pressure	[bar] Pilot drain internal: P, A, B, X 350; T, Y 210 Pilot drain external: P, A, B, T, X 350; Y 210			
Fluid	Hydraulic oil according to DIN 51524...535, other on request			
Fluid temperature	[°C] -20...+60 (NBR: -25...+60)			
Viscosity permitted	[cSt] / [mm <sup>2</sup> /s] 20...400			
Viscosity recommended	[cSt] / [mm <sup>2</sup> /s] 30...80			
Filtration	ISO 4406; 18/16/13			
Nominal flow	at Δp=5 bar per control edge <sup>2)</sup> [l/min]			
Max. recommended flow	[l/min] 90 / 120	200	450	1000
Leakage at 100 bar, main stage	[ml/min] 250	600	1000	3000
Leakage at 100 bar, pilot stage	[ml/min] 200	200	600	1000
Opening point	[%] <100			
Pilot supply pressure	[bar] set to 10 command signal (see flow characteristics)			
Pilot flow, step response	[l/min] 20 - 350	2.9	4.1	6.7
			15	
<b>Static / Dynamic</b>				
Step response at 100 % step <sup>3)</sup>	[ms] 35	37	66	120
Hysteresis	[%] ≤ 0.1			
Temperature drift	[%/K] < 0.005			
Sensitivity	[%] ≤ 0.05			

<sup>1)</sup> If valves with onboard electronics are used in safety-related parts of control systems, in case the safety function is requested, the valve electronics voltage supply is to be switched off by a suitable switching element with sufficient reliability.

<sup>2)</sup> Flow rate for different Δp per control edge:  $Q_x = Q_{Nom.} \cdot \sqrt{\frac{\Delta p_x}{\Delta p_{Nom.}}}$

<sup>3)</sup> Measured with load (210 bar pressure drop / two control edges)

**Technical Data / Characteristic Curves**

Electrical characteristics			
Duty ratio		[%]	100
Protection class			IP65 in accordance with EN 60529 (with correctly mounted plug-in connector)
Supply voltage/ripple DC		[V]	18...30, electric shut-off at < 17, ripple < 5 % eff., surge free
Current consumption max.		[A]	2.0
Pre fusing medium lag		[A]	2.5
Command signal			
Code K (B)	Voltage	[V]	10...0...-10, ripple <0.01 % eff., surge free, 0...+10 V P→A (P→B)
	Impedance	[kOhm]	100
Code E	Current	[mA]	20...0...-20, ripple <0.01 % eff., surge free, 0...+20 mA P→B
	Impedance	[Ohm]	< 250
Code S	Current	[mA]	4...12...20, ripple <0.01 % eff., surge free, 12...20 mA P→A
			< 3.6 mA = enable off, > 3.8 mA = enable on acc. to NAMUR NE43
	Impedance	[Ohm]	< 250
Differential input max.		[V]	
Code 0/7			30 for terminal D and E against PE (terminal G) 11 for terminal D and E against 0 V (terminal B)
Code 5			30 for terminal 4 and 5 against PE (terminal ⚡) 11 for terminal 4 and 5 against 0 V (terminal 2)
Adjustment ranges	Min	[%]	0...50
	Max	[%]	50...100
	Ramp	[s]	0...32.5
Interface			RS 232, parametrizing connection 5pole
Enable signal (code 5/7)		[V]	5...30
Diagnostic signal		[V]	+10...0...-10 / +12.5 error detection, rated max. 5 mA
EMC			EN 61000-6-2, EN 61000-6-4
Electrical connection	Code 0/7		6 + PE acc. to EN 175201-804
	Code 5		11 + PE acc. to EN 175201-804
Wiring min.	Code 0/7	[mm <sup>2</sup> ]	7 x 1.0 (AWG20) overall braid shield
	Code 5	[mm <sup>2</sup> ]	8 x 1.0 (AWG20) overall braid shield
Wiring length max.		[m]	50

With electrical connections the protective conductor (PE ⚡) must be connected according to the relevant regulations.

**D\*1FC B/E Flow characteristics**

(set to opening point 10 %) at  $\Delta p = 5$  bar per metering edge

**D31FC**, Spool code E01, E02, B31, B32

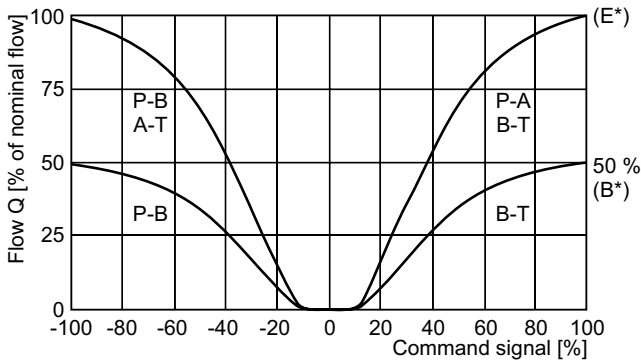

**D41FC**, Spool code E01, E02, B31, B32

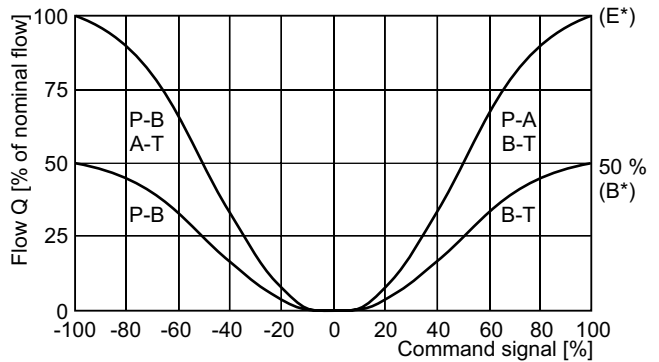

**D91FC**, Spool type E01, E02, B31, B32

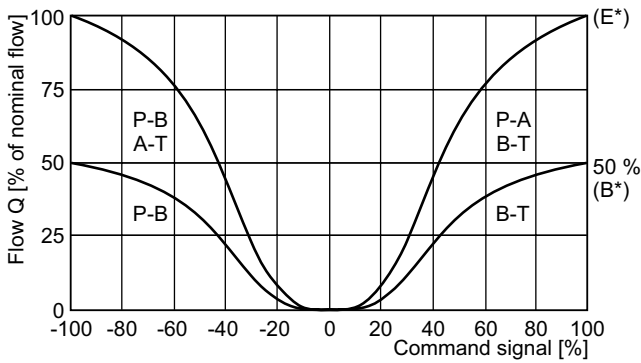

**D111FC**, Spool type E01, E02, B31, B32

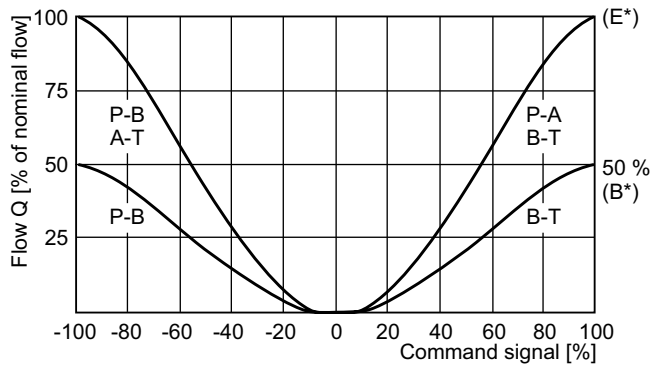

**3**

All characteristic curves measured with HLP46 at 50 °C.

**Electrical characteristics of position control M12x1 as per IEC 61076-2-101**

Supply voltage	[VDC]	24
Tolerance supply voltage	[%]	±20
Ripple supply voltage	[%]	≤10
Polarity protection	[V]	300
Current consumption without load	[mA]	≤20
Switching hysteresis	[mm]	<0.06
Max. output current per channel, ohmic	[mA]	250
Ambient temperature	[°C]	-20 ... +60
Protection		IP65 acc. EN 60529
CE conform		EN 61000-4-2 / EN 61000-4-4 / EN 61000-4-6 <sup>1)</sup> / ENV 50140 / ENV 50204
Min. distance to next AC solenoid	[m]	0.1
Interface		M12x1 acc. to IEC 61076-2-101

3

**M12x1 connector pin assignment**

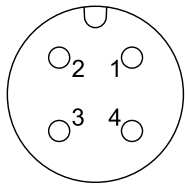

- 1 + US 19.2...28.8 V
- 2 Output B (normally closed)
- 3 0 V
- 4 Output A (normally closed)

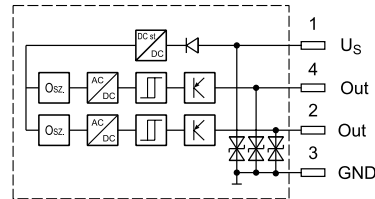

Outputs: Open collector

Signal	Output A (pin 4)	Output B (pin 2)
neutral	closed	closed
	open	closed
	closed	open

The neutral position is monitored. The signal changes after less than 10 % of the spool stroke.

Please order female connector M12x1 separately (see accessories, female connector M12x1 (order no.: 5004109).

**Wiring according EN 175201-804**

**Code 0/3, 6+PE**

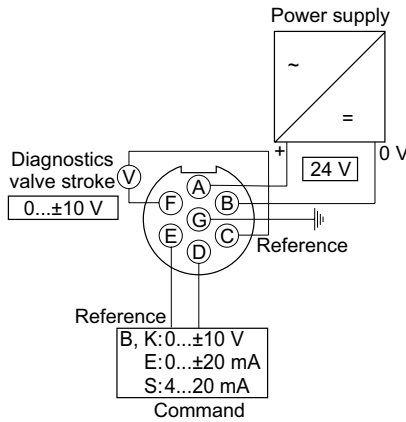

**Code 5, 11+PE**

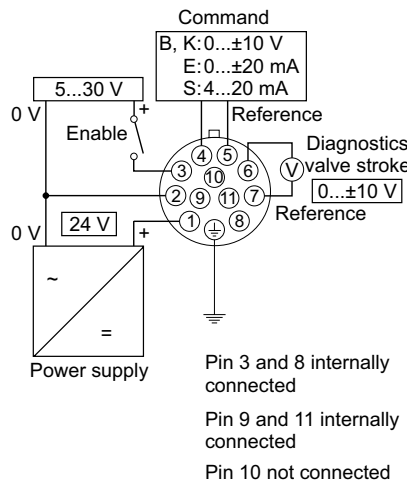

**Code 1/7, 6+PE + enable**

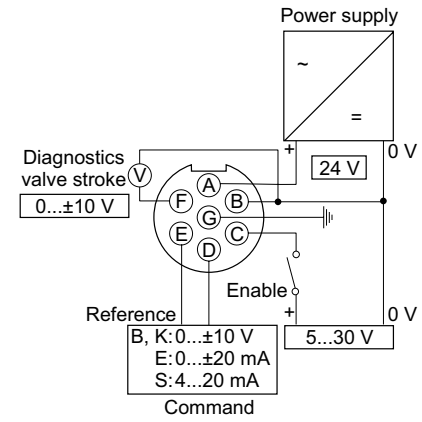

<sup>1)</sup> Only guaranteed with screened cable and female connector

**ProPxD interface program**

The ProPxD software allows quick and easy setting of the digital valve electronics. Individual parameters as well as complete settings can be viewed, changed and saved via the comfortable user interface. Parameter sets saved in the non-volatile memory can be loaded to other valves of the same type or printed out for documentation purposes.

The PC software can be downloaded free of charge at [www.parker.com/isde](http://www.parker.com/isde) – see page “Support” or directly at [www.parker.com/propxd](http://www.parker.com/propxd).

**Features**

- Comfortable editing of valve parameters
- Saving and loading of customized parameter sets
- Executable with all Windows® operating systems from Windows® XP upwards
- Simple communication between PC and valve electronics via serial interface RS232C

The valve electronics cannot be connected to a PC with a standard USB cable – this can result in damages of PC and/or valve electronics.

**The parametrizing cable may be ordered under item no. 40982923.**

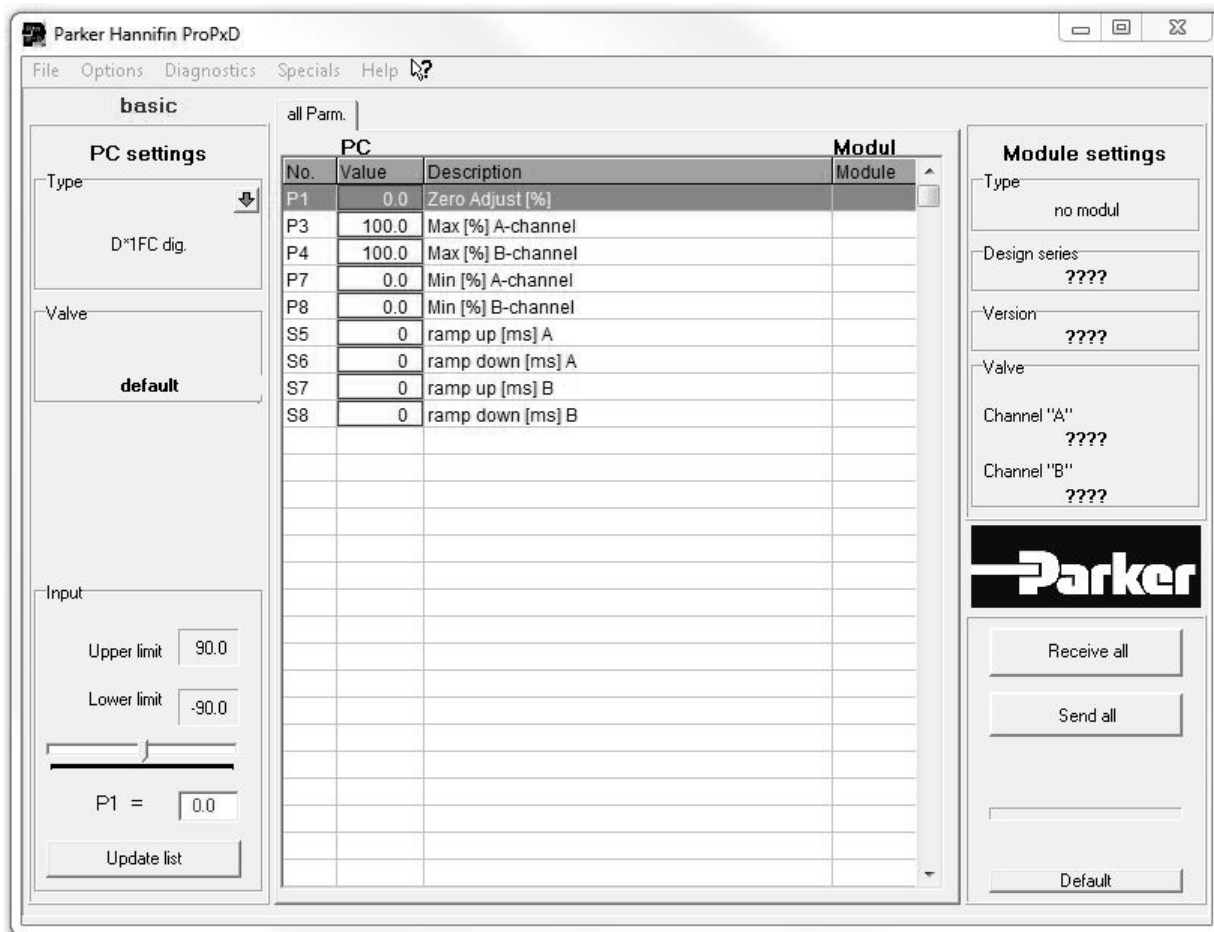

**Pilot oil inlet (supply) and outlet (drain)**

○ open, ● closed

Pilot oil		B	C
Inlet	Drain		
internal	external	○	●
external	external	●	●
internal	internal	○	○
external	internal	●	○

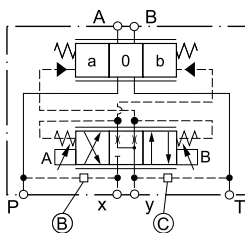

**3**

**D31FCB/E**

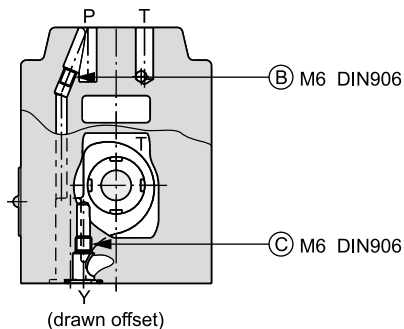

**D41FCB/E**

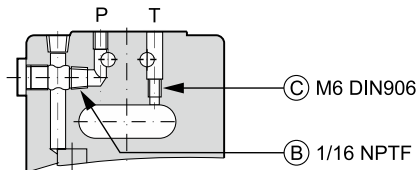

**D91FCB/E**

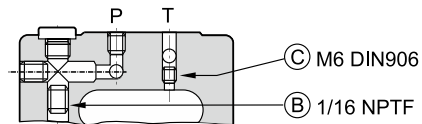

**D111FCB/E**

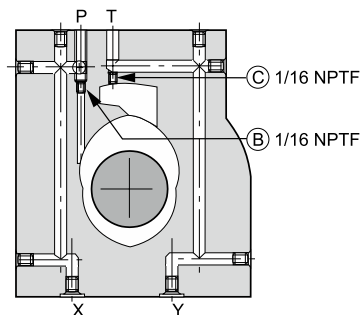



**D31FC**

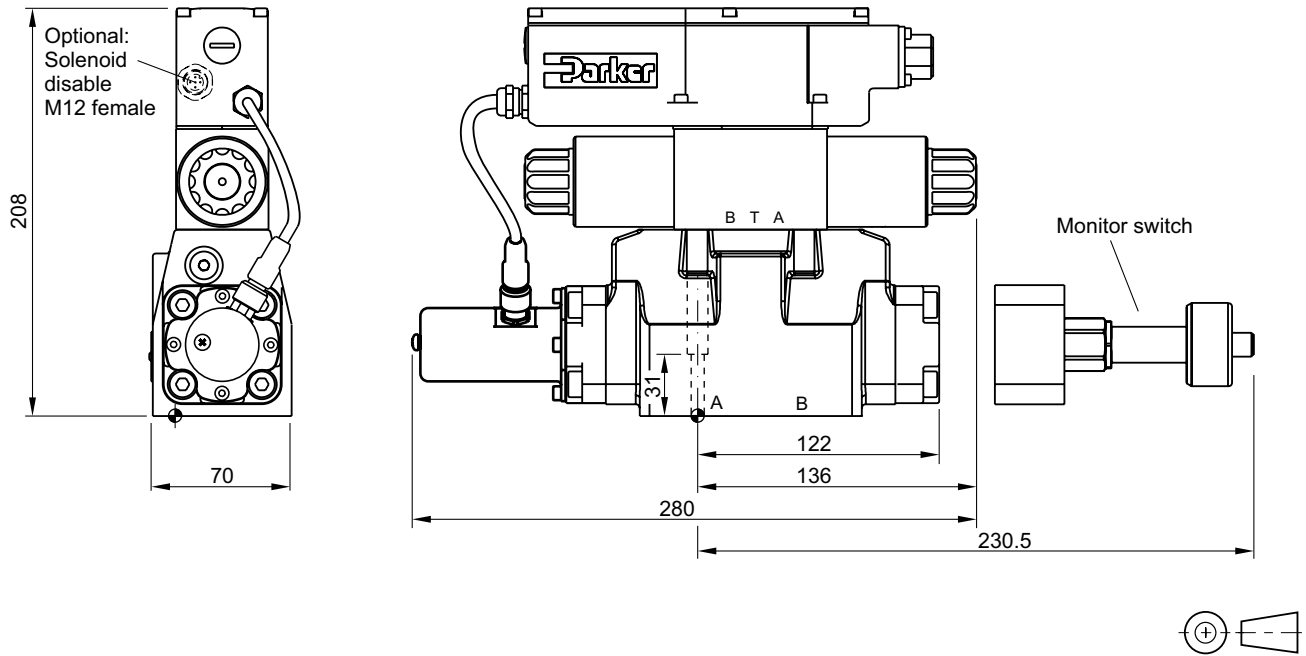

Surface finish	Kit	Kit	Kit	Kit
$\sqrt{R_{max}6.3}$ $\square 0.01/100$	BK385	4x M6x40 ISO 4762-12.9	13.2 Nm ±15 %	NBR: SK-D31FC FPM: SK-D31FC-V

**D41FC**

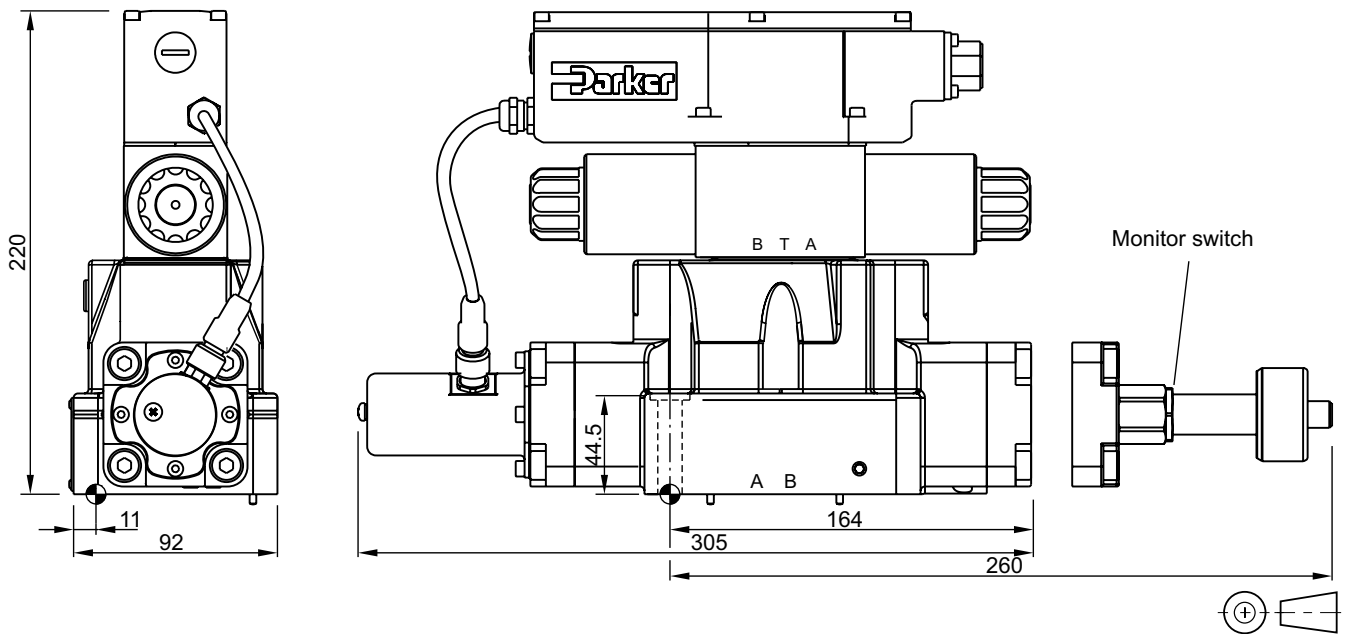



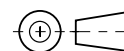
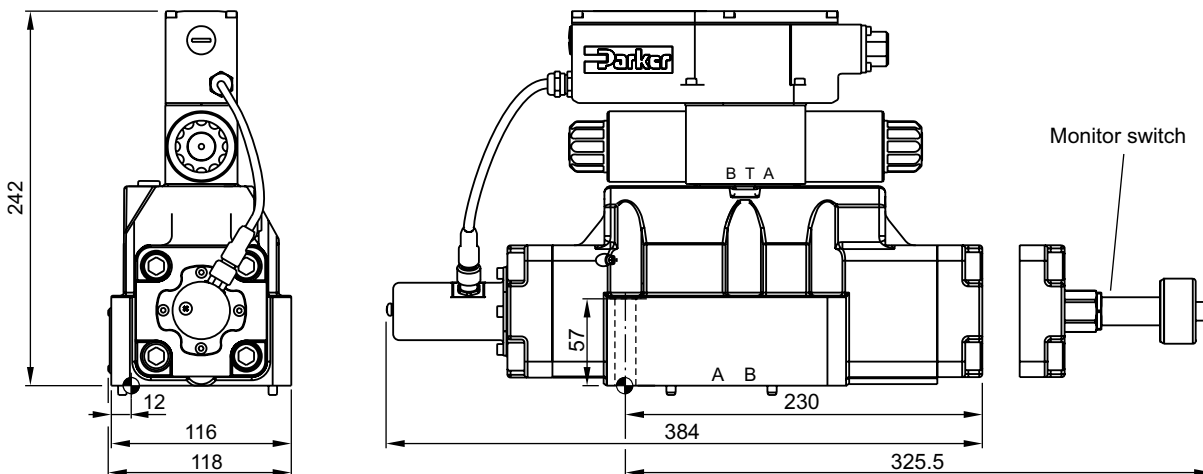

Surface finish	Kit	Kit	Kit	Kit
$\sqrt{R_{max}6.3}$ $\square 0.01/100$	BK320	2x M6x55 4x M10x60 ISO 4762-12.9	13.2 Nm ±15 % 63 Nm ±15 %	NBR: SK-D41FC FPM: SK-D41FC-V

Dimensions





D91FC

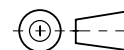
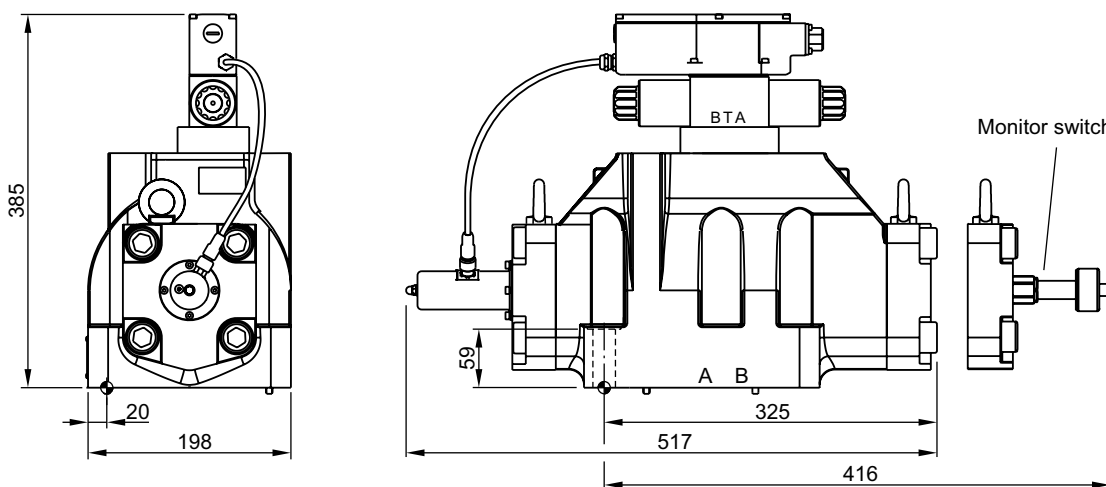

Surface finish	 Kit	 Kit	 Kit	 Kit
$\sqrt{R_{max}6.3}$ $\square 0.01/100$	BK360	6x M12x75 ISO 4762-12.9	108 Nm ±15 %	NBR: SK-D91FC FPM: SK-D91FC-V

D111FC



Surface finish	 Kit	 Kit	 Kit	 Kit
$\sqrt{R_{max}6.3}$ $\square 0.01/100$	BK386	6x M20x90 ISO 4762-12.9	517 Nm ±15 %	NBR: SK-D111FC FPM: SK-D111FC-V