

The direct operated pressure relief valves series RDM are in sandwich design for easy configuration of stock systems. They relieve the pressure of the hydraulic system to the adjusted value.

Function

PT... pressure is relieved from P to T.

TT... pressure pre-loading in T.

Features

- The direct operated, cushioned piston design results in fast response, low leakage and minimal hysteresis.
- Pressure settings:
bar 25, 64, 160, 210, 350 for RDM2,
bar 19, 50, 100, 150, 210 for RDM3.
- Adjustment modes:
- Hexagon socket
- Cylinder lock
- Turning knob
- Gauge port
- RDM2 - NG06 (CETOP 03)
RDM3 - NG10 (CETOP 05)



RDM2

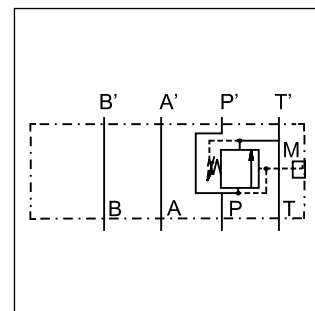

Example PT

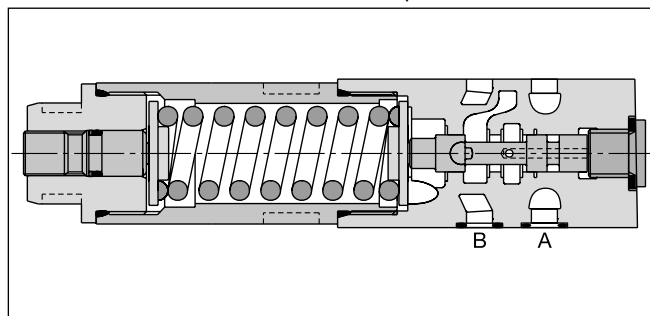

RDM2

Ordering code

RD	M					V		
Pressure relief valve, direct operated	Manapak	Size	Pressure relief	Pressure range	Adjustment	Seal FPM	Gauge port	Design series (not required for ordering)

Code	Size
2	NG06
3	NG10

Code	Gauge port
G ²⁾	G¹/₄
C	Coupling M16

Code	Pressure relief
PT	P
TT ¹⁾	T

Code	Adjustment
S	Hexagon socket
L	Cylinder lock
K	Turning knob ³⁾

Pressure range	
Code	RDM2
02	1.5 to 25 bar
06	1.5 to 64 bar
16	3 to 160 bar
21	3 to 210 bar
35	5 to 350 bar
Code	RDM3
01	1.5 to 19 bar
05	1.5 to 50 bar
10	3 to 100 bar
15	3 to 150 bar
21	3 to 210 bar

Bold letters = Short-term availability

¹⁾ NG06 only, max. 160 bar.

²⁾ Standard in housing.

³⁾ NG06 only.

Technical data

General			
Series		RDM2	RDM3
Size		NG06	NG10
Mounting interface		ISO 4401	
Weight	[kg]	1.3	2.6
MTTF _D value	[years]	150	
Ambient temperature	[°C]	-20...+60	
Hydraulic			
Max. operating pressure	P, A, B [bar]	350	315
	T [bar]	50	10
Fluid		Hydraulic oil according to DIN 51524	
Fluid temperature	[°C]	-20...+70	
Viscosity, permitted	[cSt] / [mm ² /s]	20 ... 400	
Viscosity, recommended	[cSt] / [mm ² /s]	30 ... 80	
Filtration		ISO 4406 (1999); 18/16/13	
Max. flow	[l/min]	40	80

Performance curves

RDM2 02

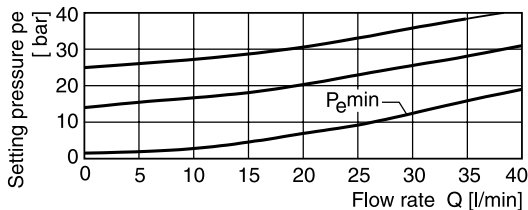

RDM2 06

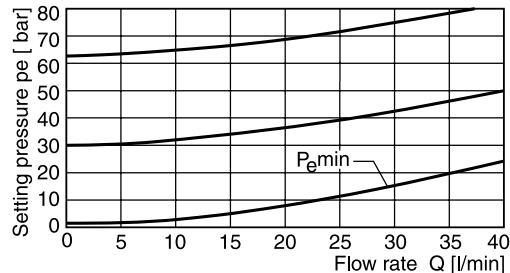

RDM2 16

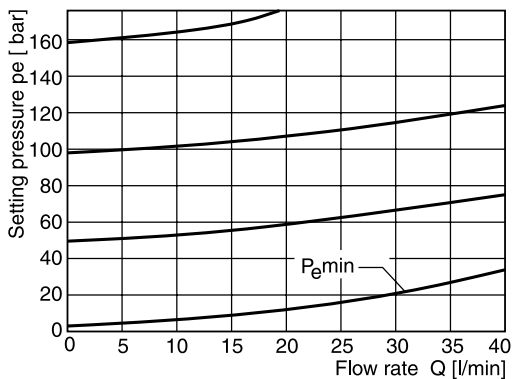

RDM2 21

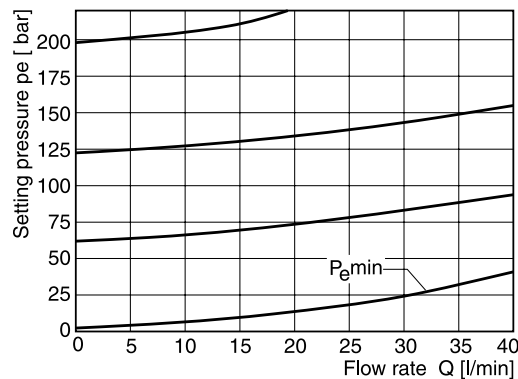

RDM2 35

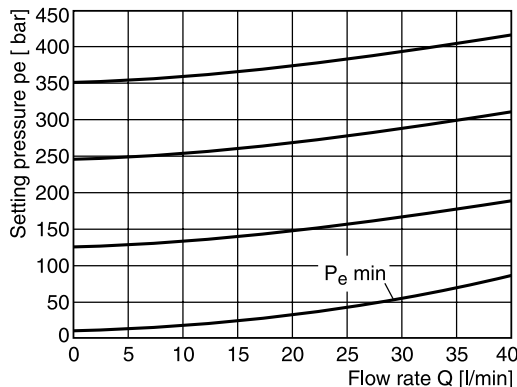

All characteristic curves measured with HLP46 at 50 °C.

7

RDM3 01

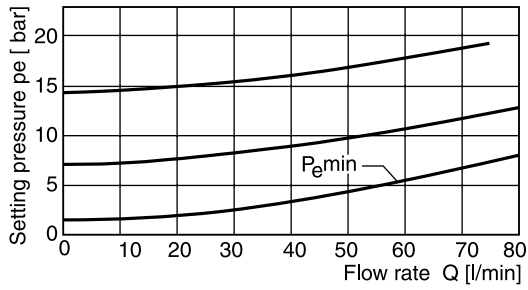

RDM3 05

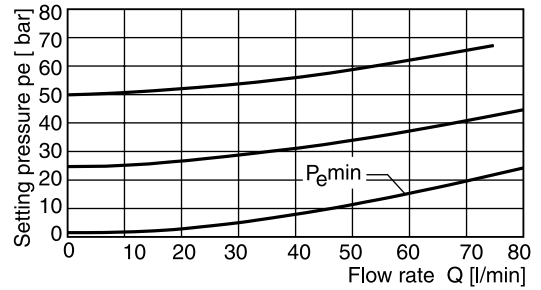

RDM3 10

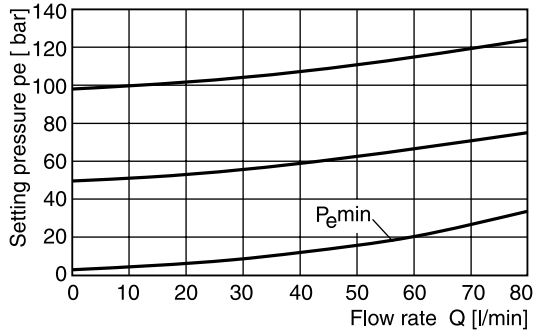

RDM3 21

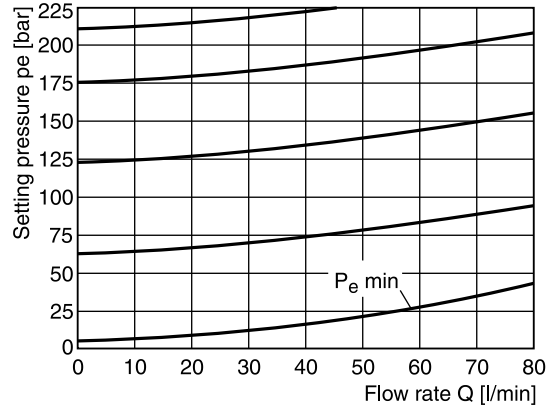

RDM3 15

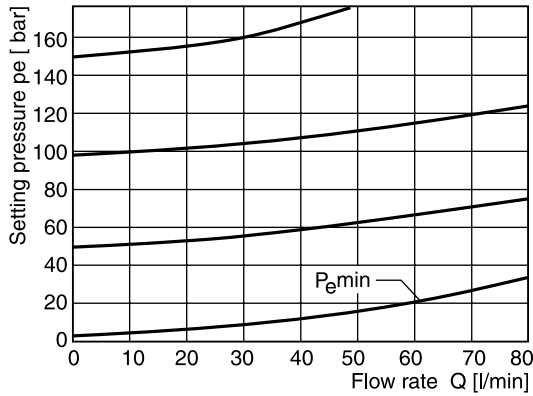

All characteristic curves measured with HLP46 at 50 °C.

Schematics

RDM*PT

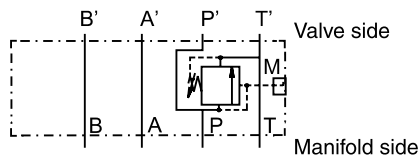

RDM*TT

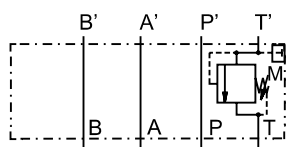

Gauge port option C

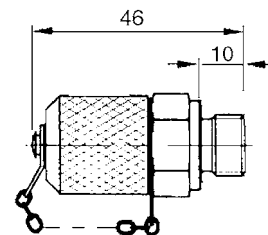

RDM2

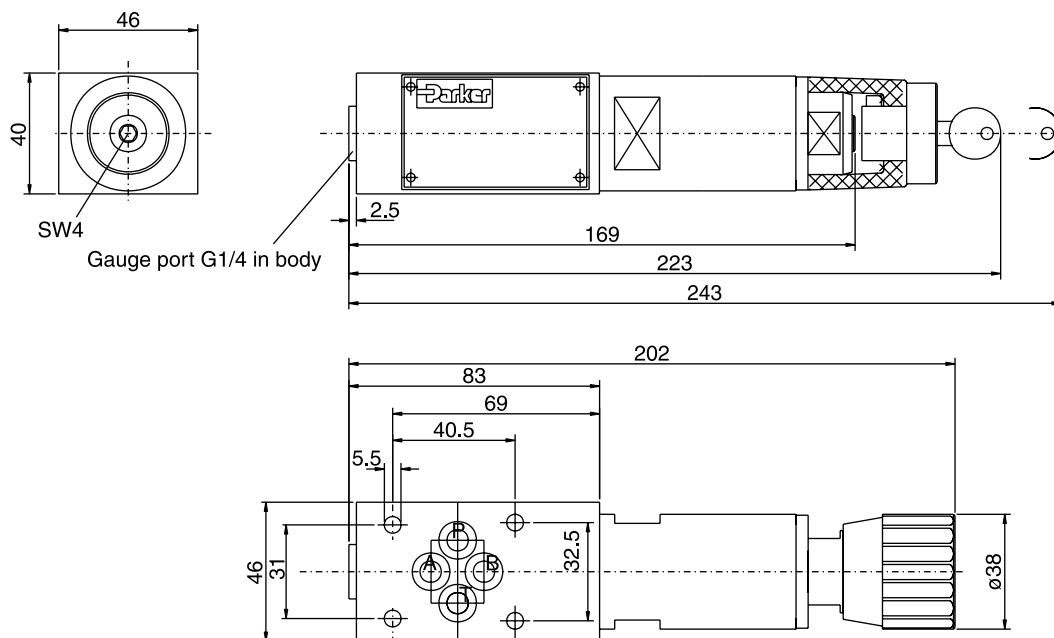

7 RDM3

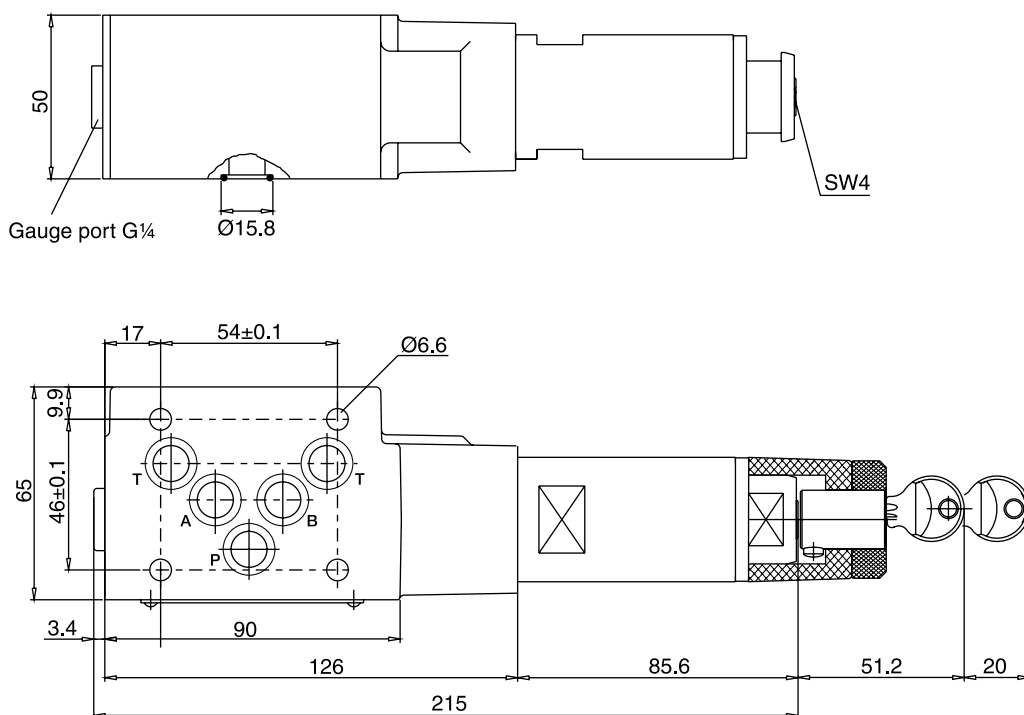

Seal kit order code		
Seal	RDM2	RDM3
V	SK-RDM2-V	SK-RDM3-V

