

# K220LS

## Mobile Directional Control Valve

Proportional, load sensing, pressure pre-compensated



ENGINEERING YOUR SUCCESS.

## Catalogue layout

In addition to general information and basic technical data, this catalogue contains descriptions of the optional functions you can configure for the K220LS, so that we may customize it to control your machine optimally.

Each function area of the valve is given as a subheading, followed by a brief description. When different positions are available for a function area, the subheading has a position number in square brackets, e.g. [P16] Pressure relief valve. This is followed by a series of coded options, e.g. PA1, Y, together with a brief description for each code.

Alternatively, one or more pressure, flow or voltage options are given. The position number is also seen in the configuration code report and in the spare part list.

On page 8 is a general hydraulic circuit, which shows the basic function areas of the K220LS valve, as well as the item numbers that represent them.

## This is how you order your valve

We have developed software to configure the K220LS. It also generates technical documents containing a detailed code report, 3D model, 2D drawing, spare part list and hydraulic circuit for your valve. The software creates a unique ID number that is printed on the valve product tag. Your valve configurations are stored in our database to facilitate rapid identification in the event of service enquiries or re-ordering.

## Save time and money with early consultations

Our experienced engineers have in-depth knowledge of different types of hydraulic systems and the ways in which they work. They are at your disposal to offer expert advice on the best system for the desired combination of machine functions, control characteristics and economic criteria. By consulting Parker early in the project planning stage, you are assured of a comprehensive hydraulic system that gives your machine the best possible operating and control characteristics.

Parker reserves the right to modify products without prior notice. Typical curves and diagrams are used in this catalogue. Even though the catalogue is revised and updated continuously, there is always the possibility of errors. For more detailed information about the product, please contact Parker Hannifin.



## **WARNING - USER RESPONSIBILITIES**

**FAILURE OR IMPROPER SELECTION OR IMPROPER USE OF THE PRODUCTS DESCRIBED HEREIN OR RELATED ITEMS CAN CAUSE DEATH, PERSONAL INJURY AND PROPERTY DAMAGE.**

This document and other information from Parker-Hannifin Corporation, its subsidiaries and authorized distributors provide product or system options for further investigation by users having technical expertise.

The user, through its own analysis and testing, is solely responsible for making the final selection of the system and components and assuring that all performance, endurance, maintenance, safety and warning requirements of the application are met. The user must analyze all aspects of the application, follow applicable industry standards, and follow the information concerning the product in the current product catalog and in any other materials provided from Parker or its subsidiaries or authorized distributors.

To the extent that Parker or its subsidiaries or authorized distributors provide component or system options based upon data or specifications provided by the user, the user is responsible for determining that such data and specifications are suitable and sufficient for all applications and reasonably foreseeable uses of the components or systems.

## **Offer of sale**

Please contact your Parker representation for a detailed "Offer of sale".

<b>Content</b>	<b>page</b>
General information .....	4
Technical data.....	5
[P03-P09] General.....	6-7
Hydraulic circuit .....	8-9
Inlet section .....	10
[P10-P29] Inlet.....	10
[P12] Internal pilot pressure supply .....	11
[P13] Pilot pressure .....	11
[P14] Pilot filter .....	11
[P15] Inlet section types .....	11
[P16] Pressure relief valve.....	12
[P17] Pressure setting .....	12
[P20] Copy spool .....	13
[P24] Tank connection T2 .....	14
[P25] Tank connection T1 .....	14
[P26] Pump connection P1 .....	14
[P28] Separate tank connection for the pilot circuit .....	14
End section.....	15
[P30 - P44] End section.....	15
[P31] LS connection .....	15
[P32] Pump connection P2.....	15
[P34] Tank connection T3 .....	15
[P40] Tank connection for the pilot circuit .....	15
Work section.....	16
[P45-P89] Work section.....	16
[P47] Connections.....	16
[P50] Spool actuators .....	17
PC/PCH Hydraulic spool actuator .....	17
ECS2/EC2/ECH2 Electrohydraulic spool actuator .....	18
[P51] Lever bracket.....	19
[55A, B] Pilot restrictor.....	20
[P56] Connector type.....	20
[P59] Spool actuator variant .....	20
[P60-P74] Spool selection .....	21
[P60] Spool function .....	21
[P64A, B] Force feedback.....	22
[P66] Pressure compensator and load-hold check valve.....	23
[P69] Spool designation .....	24
[P71A, B] Nominal flow to work port.....	24
[P72] Flow settings .....	24
[P74] Variant for work section .....	24
[P75] Feed reducer valve.....	25
[P75A] [P75B] Setting feed reduction in ports A and B .....	25
[P76A, B] Pressure relief and anti-cavitation valves .....	26
[P85] Side port connection .....	26
[P89A, B] Workport variant .....	26
[P90-P99] Function block .....	27
Accessories .....	27
Information.....	28
[P50] EC2 manual override .....	28
Dimensional drawing .....	29
Spare parts.....	30

[P00] refers to an item number in the customer specification

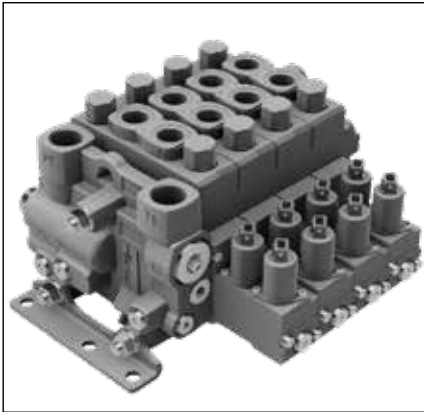

K220LS with threaded ports.

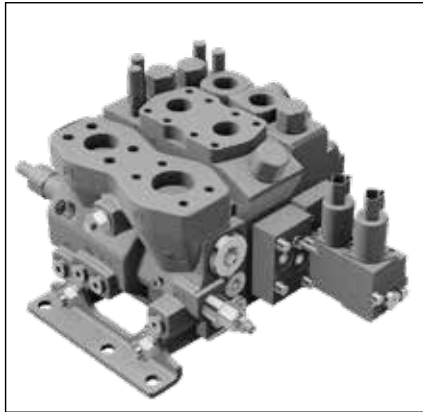

K220LS with two types of work sections, with flange connection and with threaded ports.

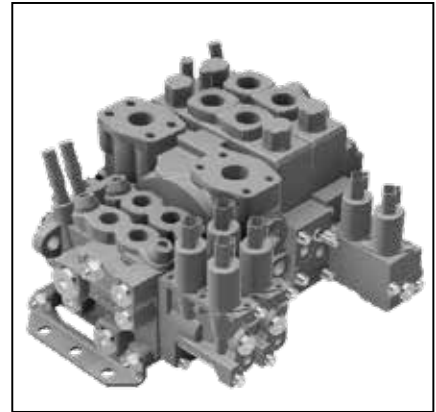

K220LS in combination with L90LS.

The K220LS is a section-built, load sensing, directional control valve for mobile machinery. The valve is characterised by industry-leading properties regarding robustness, precision control and energy efficiency.

It has a wide range of selectable functions, offering great flexibility in terms of system structure for simple and advanced hydraulic system solutions. The K220LS can be equipped with hydraulic or electrohydraulic spool actuators in any combination. Each valve section can be optimised for a function in the machinery, with a large range of spools, pressure relief valves, pressure compensators, signal pressure limiters and other performance-enhancing functions.

The K220LS can be constructed in many different designs, with different inlet sections, work sections and end sections. The valve sections are individually specified with threaded or flange ports. The K220LS can also be combined with the smaller L90LS directional valve in order to further optimise functional performance in machinery with large variations in flow requirements.

With complete customer-specific functional adaptations and to accommodate needs to control auxiliary functions, the K220LS can be combined with tailor-made function manifolds from Parker.

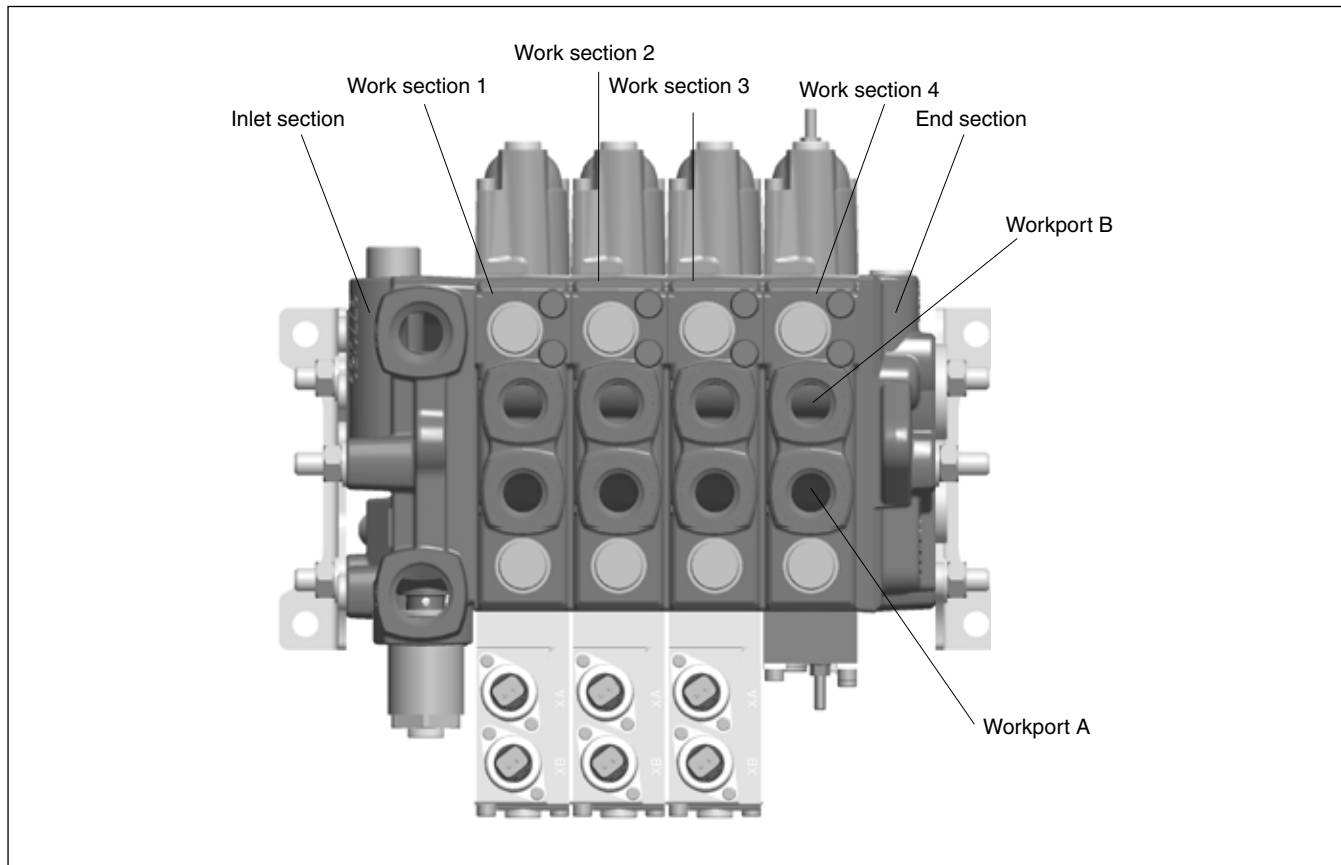

**Pressure**

Pump inlet	max 330 bar
Workports	max 350 bar
Tank, static	max 20 bar

**Internal pilot pressure**

Fixed setting	35 bar or 45 bar
---------------	------------------

**Flow capacity**

Pump connection	400 l/min
Workport with LS compensator*	290 l/min
Workport with AS compensator*	220 l/min
Workport without compensator*	350 l/min

\*Indicated for ΔP 20 bar over the valve

**Weight**

The weights below are approximate and may vary according to the valve configuration.

Inlet section, [P15] LS2 + [P10] PT	8.5 kg
Inlet section, [P15] AS, AS2, LS2, CFC + [P10] FC	11.4 kg
Inlet section, [P15] LS2C, AS2C	11.5 kg
Work section with PC spool actuator, [P47] PT	9.1 kg
Work section with PC spool actuator, [P47] FC	13.1 kg
Work section with EC2 spool actuator, [P47] PT	10.8 kg
Work section with EC2 spool actuator, [P47] FC	14.5 kg
End section, [P30] US	4.1 kg

**Filtration**

Filtration must be arranged so that Target Contamination Class 20/18/14 according to ISO 4406 is not exceeded. For the pilot circuit, Target Contamination Class 18/16/13 according to ISO 4406 must not be exceeded.

**Hydraulic fluids**

Best performance is obtained using mineral base oil of high quality and cleanliness in the hydraulic system.

Hydraulic fluids of type HLP (DIN 51524), oil for automatic gearboxes Type A and engine oil type API CD can be used.

Viscosity, working range 15-380 mm<sup>2</sup>/s\*\*

**Technical information in this catalogue is applicable at an oil viscosity of 30 mm<sup>2</sup>/s and a temperature of 50°C using HNBR or NBR seals.**

\*\* Product operating limits are broadly within the above range, but satisfactory operation within the specification may not be accomplished. Leakage and response time will be affected when used at temperature extremes. Performance efficiency will be reduced if the product is used outside the ideal values. These extreme conditions must be evaluated by the user to establish suitability of the product.

**Temperature**

Oil temperature, working range	+20°C to 90°C**
Oil temperature start-up, functional range	-30°C to 100°C**

**[P03] Pump regulator setting**

The pressure difference in bar at the valve between pump and load signal (PX-PL) is indicated here. The stated value applies when max. flow is taken off from the valve. The stated value applies when the pump is not overdemand. When inlet section [P15] CFC, the pressure drop at idle P1-T1 for the shunt is specified at 20 l/min in [P03]. Selection between 15-25 bar.

**Connections**

The K220LS has two different connection methods.

- Threaded ports.
- Flange connections.

The type of connection is determined as follows:

- Inlet, [P04] and [P10]
- Work section, [P04] and [P47]
- End section, [P04]

Depending on the configuration, certain connections shown in the figures below may be absent.

**[P04] Connection thread**

**MG** G-version (BSP pipe thread) for ISO 228/1 flat seal. Depending on the option in [P10] and [P47], certain ports can also have a flange connection, in which case they use metric threads for screws. Flange connection of standard pressure type according to ISO 6162-1, high pressure according to ISO 6162-2.

**MU** UNF-version for o-ring seal according to ISO 11926-1. Depending on the option in [P10] and [P47], certain ports can also have a flange connection, in which case they use metric threads for screws. Flange connection of standard pressure type according to ISO 6162-1, high pressure according to ISO 6162-2.

**UU** UNF-version for o-ring seal according to ISO 11926-1. Depending on the option in [P10] and [P47], certain ports can also have a flange connection, in which case they use UNC threads for screws. Flange connection of standard pressure type according to ISO 6162-1, high pressure according to ISO 6162-2.

Screw thread and thread depth for flange connections:

- 1) MG/MU [P04]: Screw M12  
 UU [P04]: Screw 7/16-14 UNC  
 Thread depth in section  $\geq 25$  mm
- 2) MG/MU [P04]: Screw M10  
 UU [P04]: Screw 3/8-16 UNC  
 Thread depth in section  $\geq 20$  mm
- 3) MG/MU [P04]: Screw M10  
 UU [P04]: Screw 7/16-14 UNC  
 Thread depth in section  $\geq 25$  mm

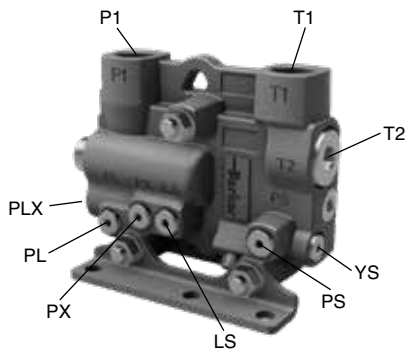

Inlet [P10] PT		
Connection	[P04] MG	[P04] MU/UU
P1, T1, T2	G 1	1 5/16-12 UN-2B
LS, PL, PX, PS, PLX	G 1/4	9/16-18 UNF-2B
YS	G 1/4	9/16-18 JIC (37° external thread)

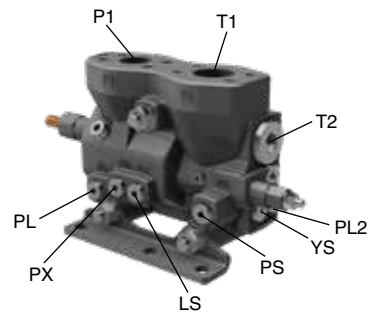

Inlet [P15] LS2, AS, AS2, CFC + [P10] FC		
Connection	[P04] MG	[P04] MU/UU
P1	Flange connection SAE 1 high pressure <sup>1)</sup>	
T1	Flange connection SAE 1 1/4 standard pressure <sup>3)</sup>	
T2	G 1	1 5/16-12 UN-2B
LS, PL, PX, PS, PL2	G 1/4	9/16-18 UNF-2B
YS	G 1/4	9/16-18 JIC (37° external thread)

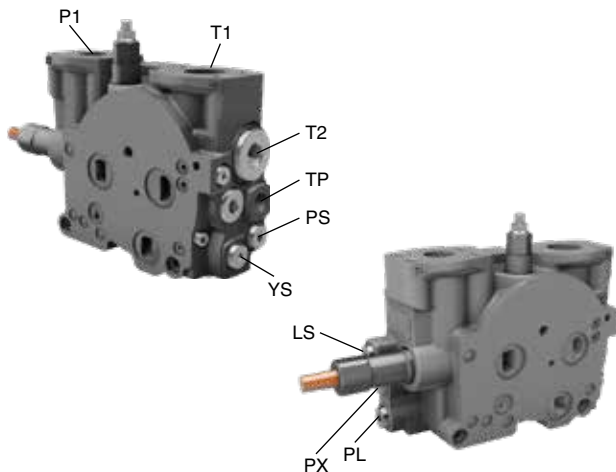

Inlet [P15] LS2C, ASC + [P10] FC		
Connection	[P04] MG	[P04] MU/UU
P1	Flange connection SAE 1 high pressure <sup>1)</sup>	
T1	Flange connection SAE 1 1/4 standard pressure <sup>3)</sup>	
T2	G 1	1 5/16-12 UN-2B
LS, PL, PX, PS	G 1/4	9/16-18 UNF-2B
YS	G 1/4	9/16-18 JIC (37° external thread)
TP	G 3/8	3/4-16 UNF-2B

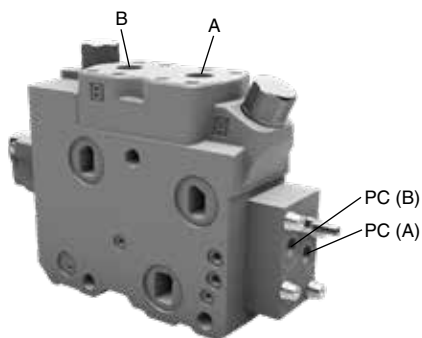

Work section [P47] FCS		
Connection	[P04] MG	[P04] MU/UU
A, B	Flange connection SAE 1 standard pressure <sup>2)</sup>	
PC	G 1/4	9/16-18 UNF-2B
Work section [P47] FCH		
Connection	[P04] MG	[P04] MU/UU
A, B	Flange connection SAE 3/4 high pressure <sup>2)</sup>	
PC	G 1/4	9/16-18 UNF-2B

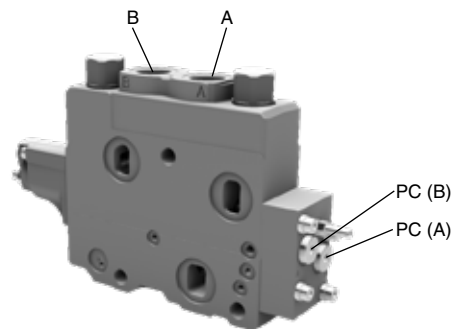

Work section [P47] PT		
Connection	[P04] MG	[P04] MU/UU
A, B	G3/4	1 1/16-12 UN-2B
PC	G 1/4	9/16-18 UNF-2B

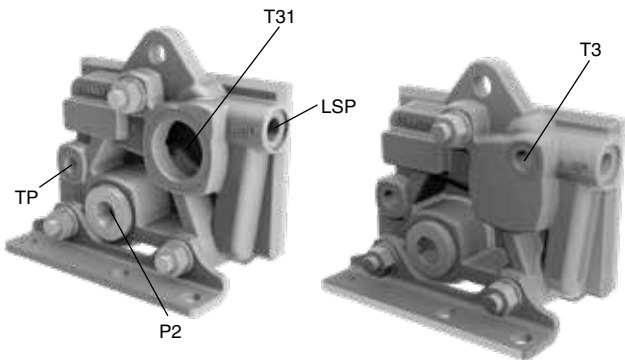

End section [P31] US		
Connection	[P04] MG	[P04] MU/UU
P2	G 1	1 5/16-12 UN-2B
T3, TP	G 1/4	9/16-18 UNF-2B
T31	G 1 1/4	1 5/8-12 UNF-2B
LSP	G 3/8	9/16-18 JIC (37°) (male)

**[P09] Mounting bracket**

/ Standard mounting brackets.

**A054** Mounting bracket thinner than standard. This mounting bracket has a larger outlet for P2 connection in the end section allowing more space for the connection nipple. Mounting bracket for inlet according to A304.

**A304** Mounting bracket thinner than standard. This mounting bracket is standard in the K170LS.





Hydraulic circuit for valve with [P15] CFC inlet section and [P66] LS compensators:

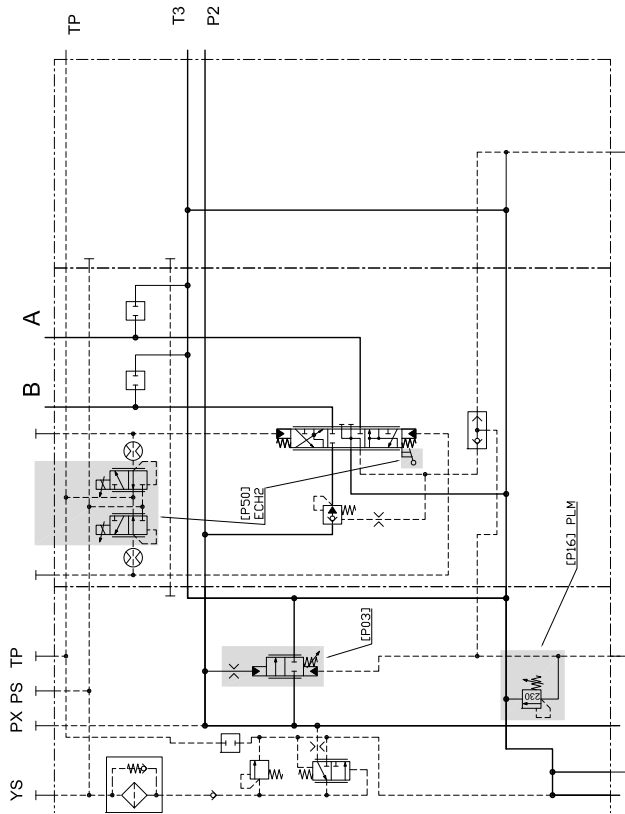

Hydraulic circuit for valve with [P15] AS inlet section and [P66] AS compensators:

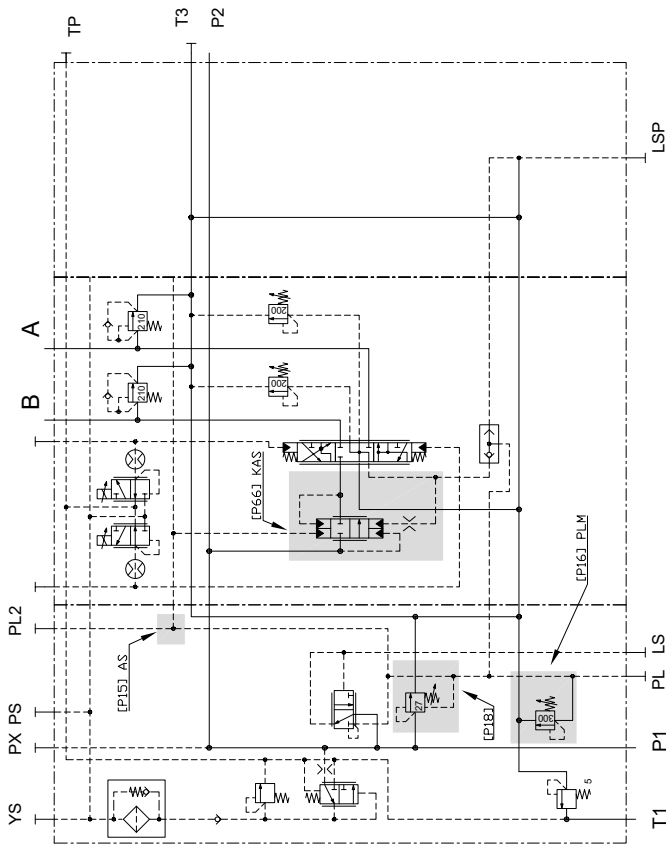

Alternative options:

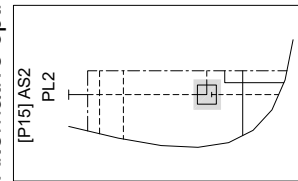

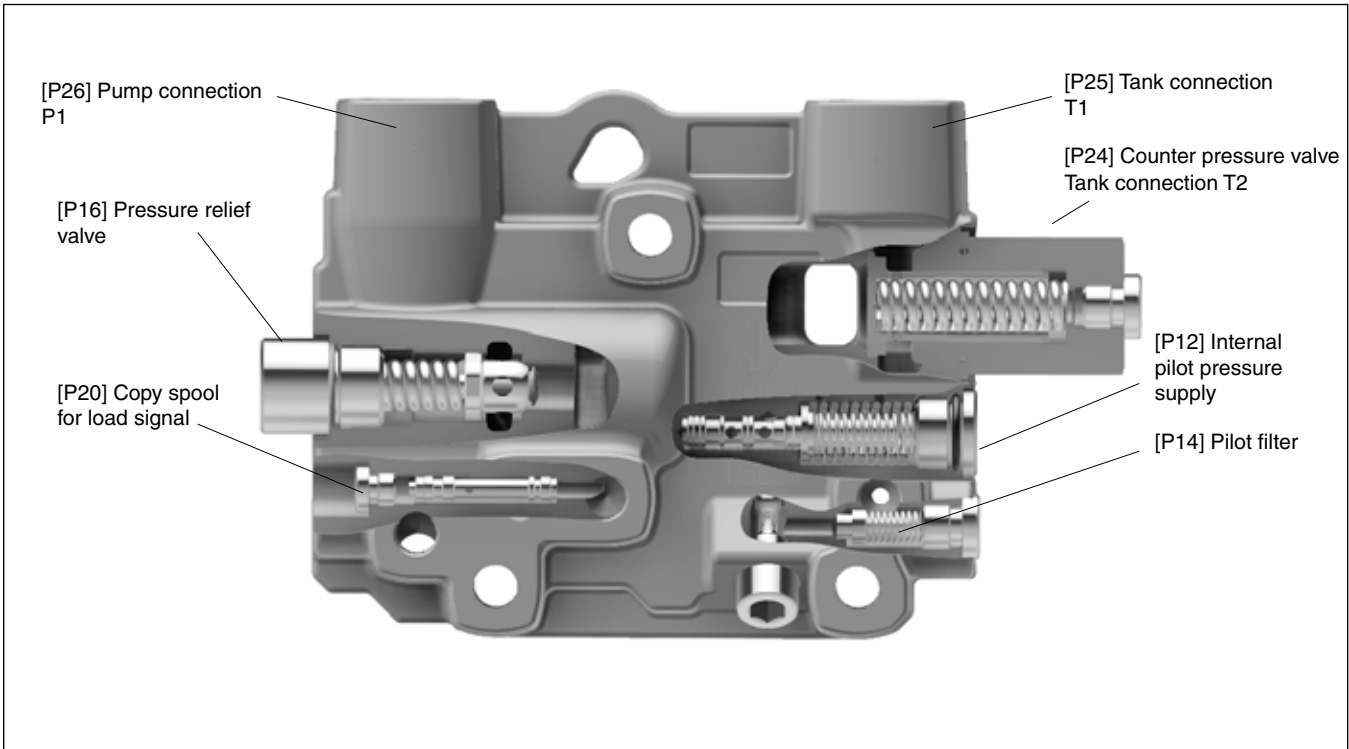

**[P10-P29] Inlet section**

There are two types of inlet sections depending on the choice of compensator [P66] in the work sections. If work sections only have LS compensators, a [P15], LS2 or LS2C inlet is used with a variable pump, or CFC with a fixed pump. If any work section has an AS compensator, then use a [P15] AS, AS2 or ASC inlet.

**[P10] Connections**

- FC** P1 and T1 have flange connections. Other connections are threaded.
- PT** All connections are threaded.



[P10] FC, [P10B] B86

**[P10B] Section type**

- B86** Section width, 86 mm.
- S67** Section width, 67 mm.



[P10] PT, [P10B] S67

**Inlet section**

**[P12] Internal pilot pressure supply**

- /** Not prepared for pilot pressure supply.
- R** Internal reducing valve for pilot pressure supply of the spool actuators. Includes a pressure relief valve to protect the pilot circuit and a check valve to prevent pilot oil from leaking back to the pump. There is a PS port for external use of the reduced pilot pressure.
- RX** Not prepared for pilot pressure supply. There is a PS port for external supply of pilot pressure.

$\Delta p$  (bar) Internal pilot pressure supply characteristics

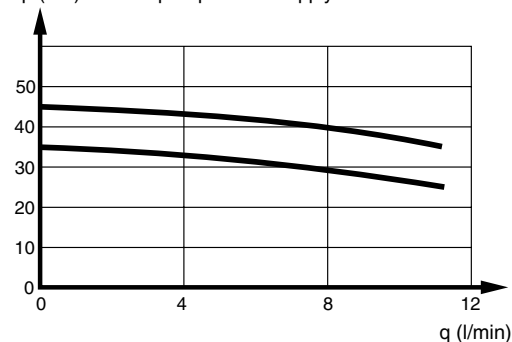

**[P13] Pilot pressure**

The pilot pressure can be set at either 35 or 45 bar.

**[P14] Pilot filter**

- S** Strainer with bypass function in the internal pilot pressure supply.
- YS** Blocks the connection between the internal pilot pressure supply and the spool actuators. The reduced pilot pressure can be tapped in the YS connection. Normally used as the outlet for the internal pilot pressure supply to an external filter. The return oil from the filter is connected to PS port to supply the spool actuators.

**[P15] Inlet section types**

- LS2** Inlet section used if all work sections have a [P66] LS compensator, for systems with a variable pump. Can be used in the first and subsequent valves in the system.
- LS2C** Inlet section combining directional valve K220LS with L90LS. Used if all work sections have a [P66] LS compensator, for systems with a variable pump. Can be used in the first and subsequent valves in the system.
- AS** Inlet section used if any of the work sections have a [P66] AS compensator, for systems with a variable pump. Can only be used in the first valve in a system.
- AS2** Inlet section used if any of the work sections have a [P66] AS compensator, for systems with a variable pump. Can only be used in the subsequent valves in a system. AS2 does not have [P18] PLS.
- ASC** Inlet section combining directional valve K220LS with L90LS. Used if any of the work sections have a [P66] AS compensator, for systems with a variable pump. Can only be used in the first valve in a system.
- CFC** Inlet section used if all work sections have a [P66] LS compensator, for systems with a fixed pump. Can only be used in the first valve in the system.



$\Delta p$  (bar) CFC - pressure drop at idle across the shunt, P1-T1

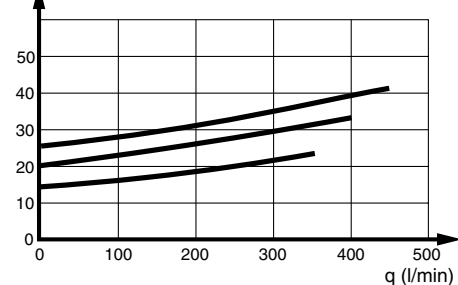

**[P15] Applies to inlet section LS2 and LS2C**

**[P16] Pressure relief valve**

**[P17] Pressure setting**

**Y1** [P16] Blocks the connection between the pump and the tank.

**PA1** [P16] Direct acting pressure relief valve with a very fast opening sequence and good pressure characteristics. Acts as a pressure relief gallery. When the pressure relief valve opens, a connection is established between the pump and the tank. Available with the following pressure settings (bar) in [P17]: 50, 63, 80, 100, 125, 140, 160, 175, 190, 210, 230, 240, 250, 260, 280, 300, 330, 350, 380.

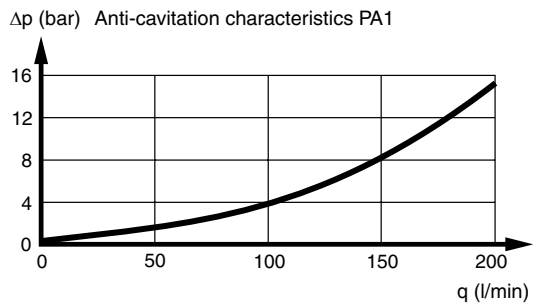
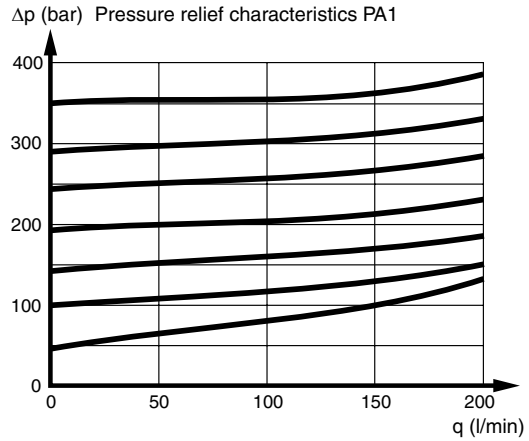

**[P15] Applies to inlet section AS, AS2, ASC and CFC**

**[P16] Pressure relief valve**

**[P17] Pressure setting**

**[P18] PLS**

**PLM** [P16] With inlet section [P15] AS, AS2, ASC: Adjustable signal pressure relief valve which limits the load signal to the pump. The pump regulator setting stated in [P03] is added to the load signal to calculate the maximum pressure in the pump gallery. The setting for PLM is selectable between 176-350 bar in [P17]. To ensure that [P66] AS compensators work correctly, the main pressure level must be limited using the PLM function.

[P16] With inlet section [P15] CFC: Adjustable signal pressure relief valve, which limits the pump pressure by the shunt spool opening the P1-T1 connection at the value set in [P17].

**PLS** [P18] Combined with PLM, it becomes a pilot-controlled adjustable pressure limitation valve. Acts as a pressure relief valve in the pump channel, which limits the pressure difference between pump pressure and load signal pressure in order to prevent disruptions to functions with [P66] AS compensators.

When PLS opens, a connection is established between the pump and the tank. Pilot control for PLS is taken from the load signal.

PLS setting is selectable between 20 and 38 bar.

[P15] AS2 does not have [P18] PLS function. (AS2 has a cavity plug in the PLS cavity, so it can be converted to PLS function).

/ Cavity not machined for PLS.

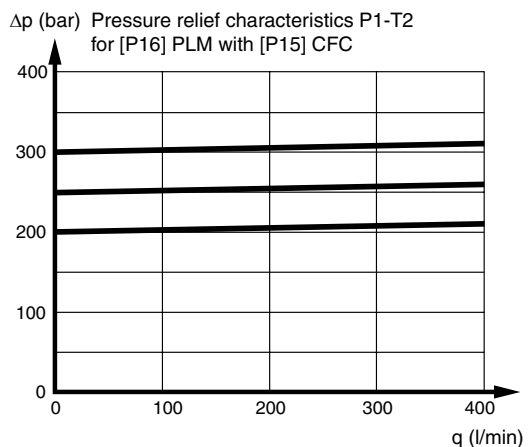
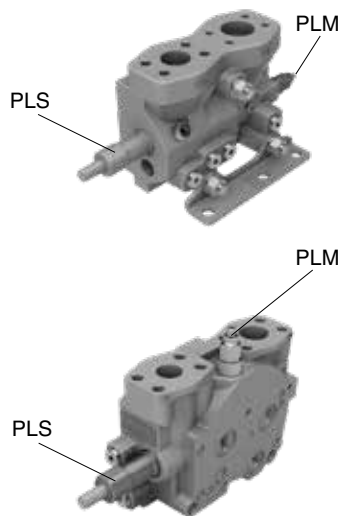

**[P20] Copy spool**

The load signal system consists of a number of shuttle valves, which compare the load signals from different work sections and any signal received from a subsequent valve connected to the LSP port [P31]. The highest load signal is sent to the pump via the connection PL in the inlet section, or to a copy spool if the section has one. The copied load signal can then be tapped from the LS port.

/ Housing not machined for copy spool.

**KS** Inlet section with copy spool.

The load signal acts on a copy spool, which sends a copied load signal to the LS connection.

The system permits a certain consumption in the load signal line to the pump regulator, without the load signal being influenced, since the copied load signal in LS is supplied with oil from the pump channel instead of taking oil from a workport.

In addition, the system prevents disruptive micro-dipping of the load during the initial stage of the lifting phase.

LS = Copied load signal  
– the oil is taken from the pump.

PL = Uncopied load signal  
– the oil is taken from the workport.

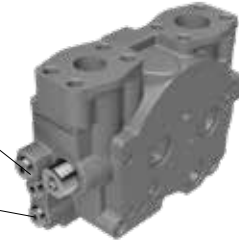

LS = Copied load signal  
– the oil is taken from the pump.

PL = Uncopied load signal  
– the oil is taken from the workport.

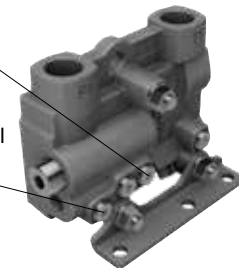

**[P24] Tank connection T2**

Can either be used as a tank connection or fitted with a counter pressure valve.

The counter pressure valve increases the pressure in the valve's tank gallery. By raising the counter pressure level the anti-cavitation characteristics of the K220LS is improved still further. Good characteristics eliminate the risk of cavitation and reduce the risk of damage to the cylinder seals. The characteristics are important for functions in which a lowering movement changes to a lifting movement without a time delay. For example, when an implement is lowered and then pressed down into the ground, or when a machine turns on sloping ground.

- T2** Tank connection T2 open.
- T2B** Tank connection T2 plugged.
- MF5** Counter pressure valve preset to give 5 bar counter pressure at a flow of 20 l/min.
- MF9** Counter pressure valve preset to give 9 bar counter pressure at a flow of 20 l/min.
- A055** Counter pressure valve preset to give 5 bar counter pressure at a flow of 20 l/min. With built-in leakage for the counter pressure when no work section is activated.
- MP** Pilot operated counter pressure valve for external control of counter pressure from 0 to 36 bar. Only provides a counter pressure on receipt of a signal. The maximum permitted signal is 30 bar. The relationship between counter pressure and signal is 1,2:1. Connection thread G1/4 or 9/16-18 UNF-2B.
- MP5** As counter pressure valve type MP with the addition of a spring providing 5 bar counter pressure at a flow of 20 l/min. Connection thread G1/4 or 9/16-18 UNF-2B.

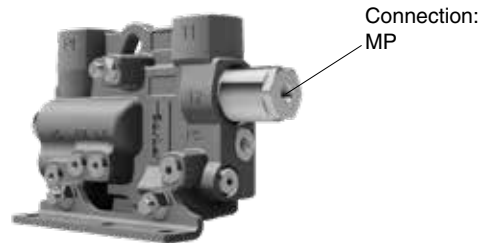
**[P25] Tank connection T1**

- T1** Tank connection T1 is open.
- T1B** Tank connection T1 is plugged.

**[P26] Pump connection P1**

- P1** Pump connection P1 is open.
- P1B** Pump connection P1 is plugged.

**[P28] Separate tank connection for the pilot circuit**

Note: Only possible with inlet section [P15] LS2C or ASC.

- /** Not machined for separate pilot return.
- TP** Separate tank connection for the pilot circuit is open. The connection to the main tank gallery of the directional valve is blocked. For more details see [P40] in the end section.
- TPB** The end section is prepared for separate tank connection of the pilot circuit and is plugged. The tank return of the pilot circuit is connected to the main tank gallery of the directional valve.

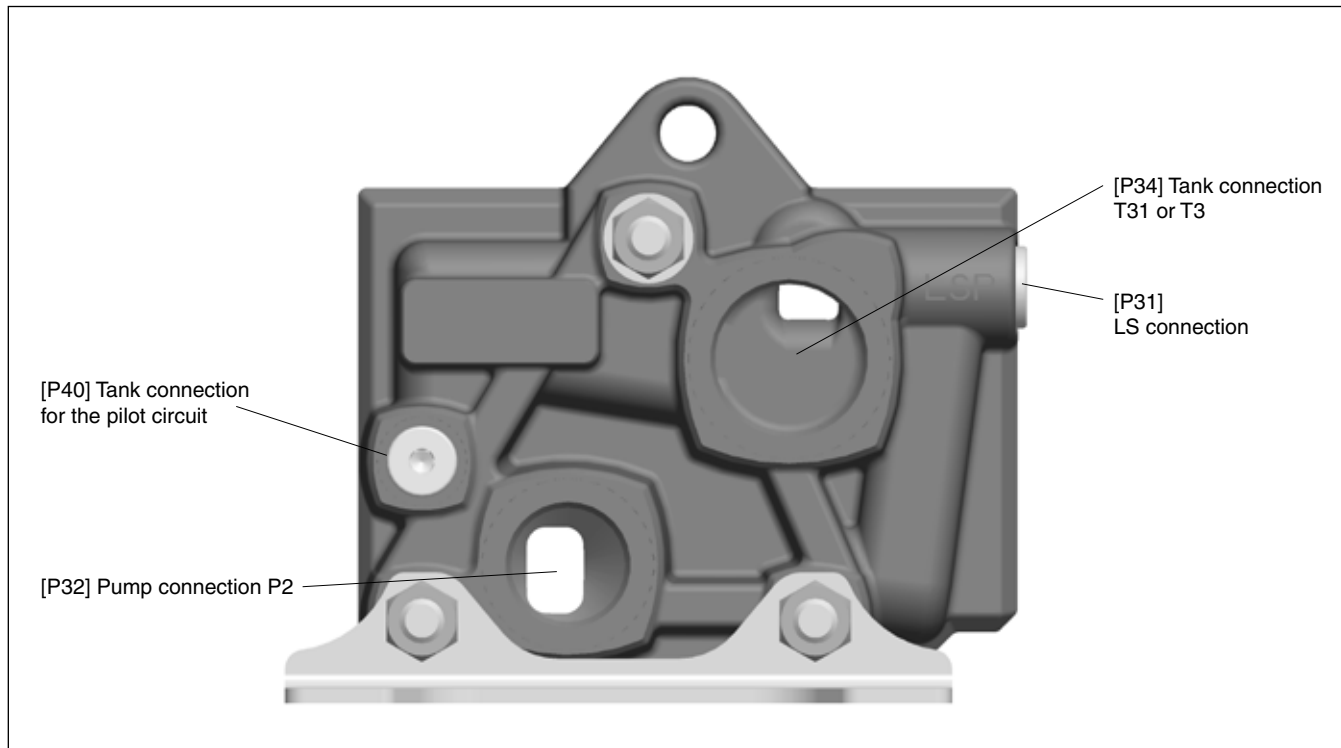

**[P30 - P44] End section**

**[P30] End section**

**US** Standard end section.

**[P31] LS connection**

Possible option of connecting the load signal from several valves, parallel connection (the oil from the pump is divided in parallel to two or more valves).

**LSP** Port LSP is open.  
 Load signal from following valves must be received via the LSP port.

**LSPB** Port LSP is plugged (cannot receive load signal from following valve via LSP port).  
 Used in one-valve system, and in the last valve in a system connected in parallel. (Can be converted into LSP function).

**[P32] Pump connection P2**

**P2** Pump connection P2 is open.

**P2B** Pump connection P2 is plugged.

**[P34] Tank connection T3**

**T3, T31** Tank connection T3 is open.

**T3B** Tank connection T3 is plugged.

**T31B**

**[P40] Tank connection for the pilot circuit**

**/** Not prepared for separate pilot return.

**TP** Separate tank connection for the pilot circuit is open. The connection to the main tank gallery of the directional valve is blocked. The function is recommended for systems in which there is a risk of dynamic pressure fluctuations in the tank line, which can cause fluctuations in the pilot circuit when there is a common tank line. TP is recommended for electrohydraulic spool actuators.

**TPB** The end section is prepared for separate tank connection of the pilot circuit and is plugged. The tank return of the pilot circuit is connected to the main tank gallery of the directional valve.

**Work section**

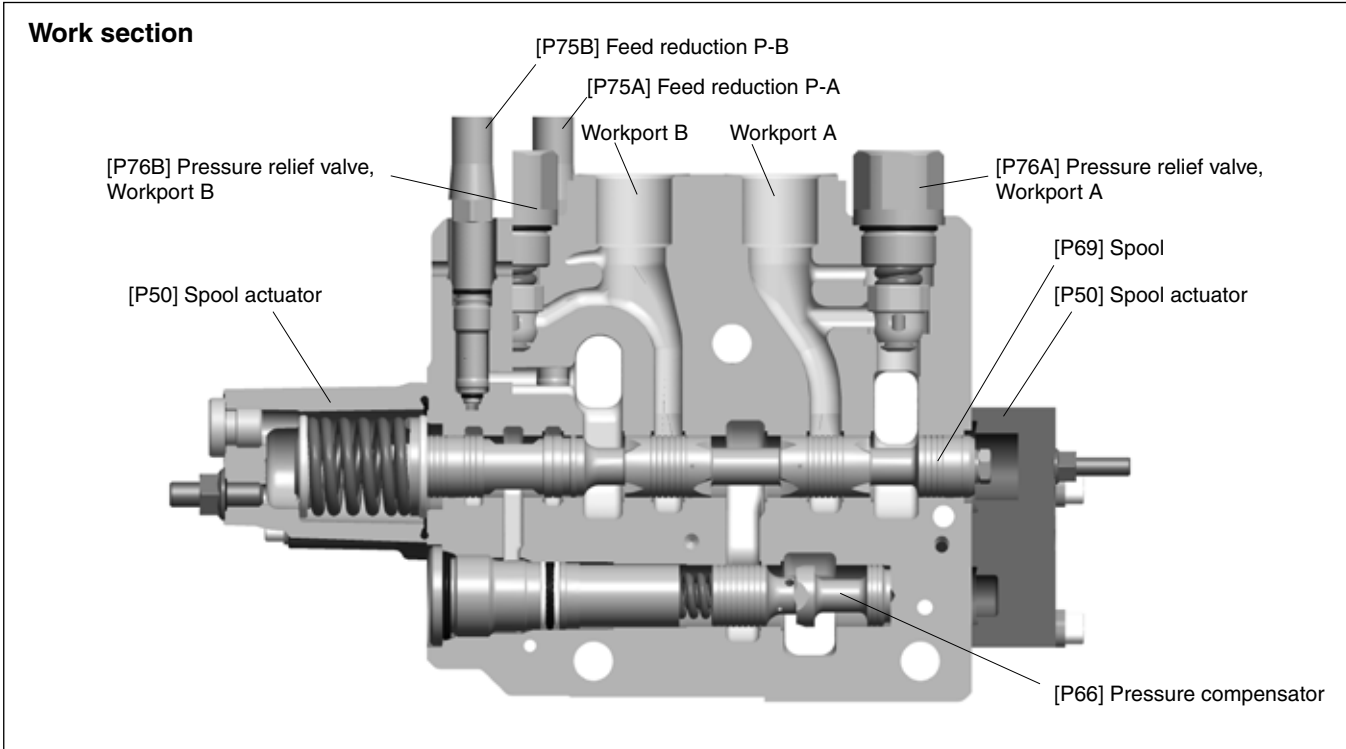

**[P45-P89] Work section**

The same valve can contain work sections with different types of spool actuators and compensators.

The maximum number of work sections varies according to selected options for the inlet [P15] and its connection [P10]:  
Inlet section LS2 with threaded ports: Maximum 10 work sections, threaded ports only [P47].

Inlet section LS2, AS and AS2 with flange connection: Maximum 8 work sections.

Inlet LS2C and ASC: Maximum 7 work sections.

**[P47] Connections**

- FCS** 1" Flange connection standard pressure.
- FCH** 3/4" Flange connection high pressure.
- PT** Threaded ports.

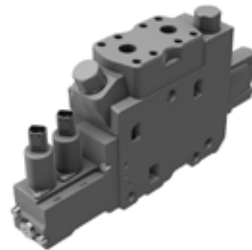

[P47] FC, [P47B] B72

**[P47B] Section width**

- B72** Section width, 72 mm. Workports have a flange connection, other ports are threaded.
- S50** Section width, 50 mm. All ports are threaded.

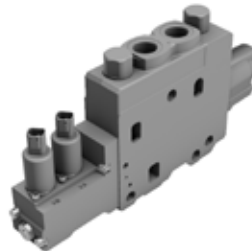

[P47] PT, [P47B] S50



**[P50] Spool actuators**

**PC Hydraulic spool actuator.**

The PC is a proportional, hydraulically controlled spool actuator with spring centring to the neutral position. It is intended for remote control using a valve of type PCL4 for example. The pilot pressure for the control pressure valve can be tapped from the internal pilot pressure supply. Permitted pressure in the pilot cap max 35 bar.  
 Control pressure, start 5.6 bar.  
 Control pressure, final 20.5 bar.

**PCH PCH Hydraulic spool actuator with hand lever**

As PC, but with the option of proportional control with hand lever.

**PC**

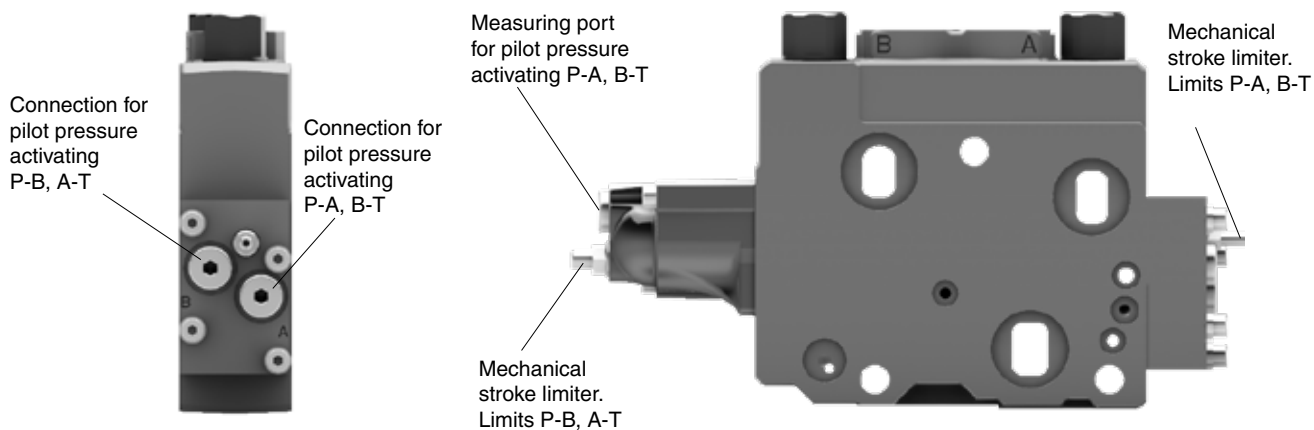

**PCH**

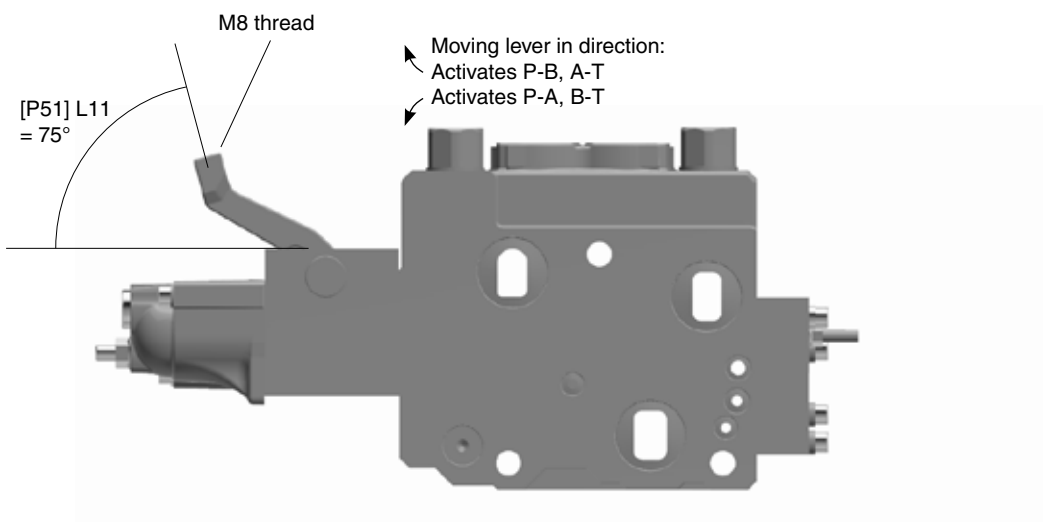

**Work section**

**ECS2 Electrohydraulic spool actuator**

The ECS2 is a proportional, hydraulically controlled spool actuator with spring centring to the neutral position. It is intended for remote control using an IQAN, for example. Pilot-pressure oil is passed to the spool actuators through internal ducts in the valve. This means that only the electric cables from the control system to the pilot solenoid valve are connected externally.

**Control current for 12 V**

Start current min 570 mA  
Final current max 1250 mA

**Control current for 24 V**

Start current min 290 mA  
Final current max 650 mA

Suitable with PWM signal.

**ECH2 ECH2 Electrohydraulic spool actuator with hand lever**

As ECS2, but with the option of proportional control with hand lever.

**EC2** The EC2 is the same as ECS2, but with manual override.  
Note: Read the information about manual override for EC2 later in the catalogue.

**ECS2/  
EC2**

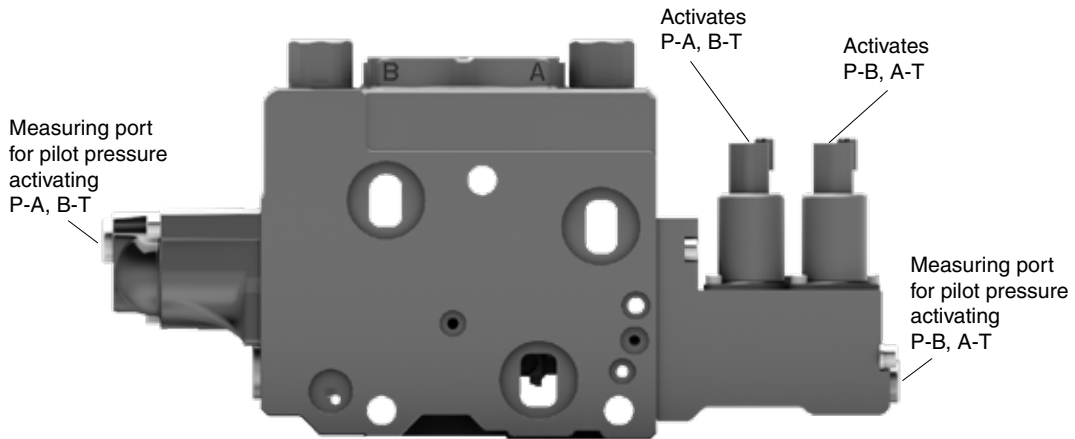

**ECH2**

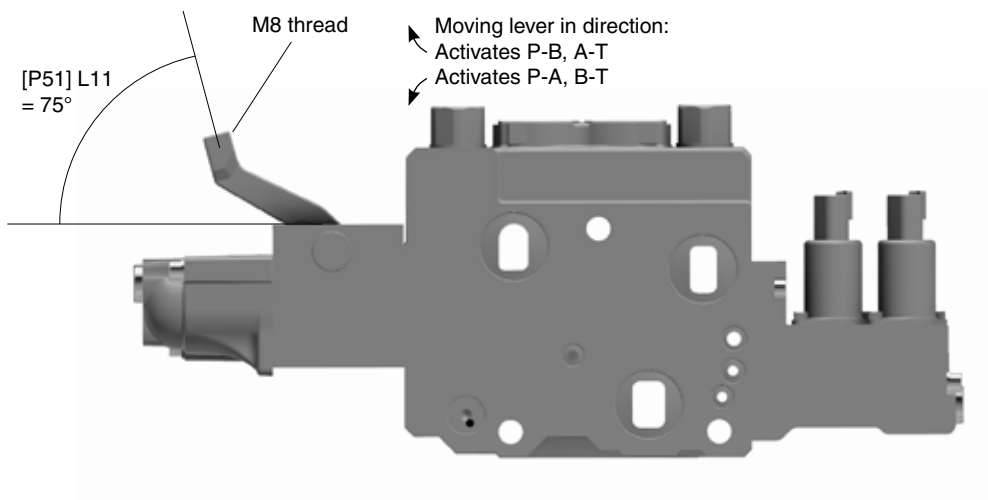

The lever handle can be fitted at two angles. Lever bracket has M8 thread for optional fitting of a lever. Levers sold separately, see "Accessories".

**[P51] Lever bracket**

**LX** Supplied without lever bracket

**L11** Lever bracket fitted at 75°

**L12** Lever bracket fitted at 15°

See picture in [P50] PCH and ECH2.

**[P55A, B] Pilot restrictor**

To allow for sensitive remote control, the EC2, ECS2, ECH2 and PCH spool actuators are fitted with pilot restrictors, which can be chosen individually for each workport. The restrictor provides a ramp function.

The following options are available for EC2, ECS2 and ECH2:

- 0.6** 0.6 mm pilot restrictor
- 0.7** 0.7 mm pilot restrictor
- 0.8** 0.8 mm pilot restrictor
- 0.9** 0.9 mm pilot restrictor
- 1.0** 1.0 mm pilot restrictor
- 1.1** 1.1 mm pilot restrictor
- 1.2** 1.2 mm pilot restrictor
- 1.3** 1.3 mm pilot restrictor
- 1.5** 1.5 mm pilot restrictor
- 2.0** 2.0 mm pilot restrictor (No damping)

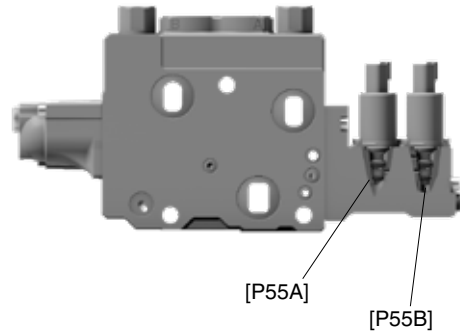

The following options are available for PC and PCH

- / Without pilot restrictor
- 0.6** 0.6 mm pilot restrictor
- 0.8** 0.8 mm pilot restrictor
- 0.9** 0.9 mm pilot restrictor
- 1.0** 1.0 mm pilot restrictor
- 1.1** 1.1 mm pilot restrictor
- 1.2** 1.2 mm pilot restrictor
- 1.3** 1.3 mm pilot restrictor
- 1.4** 1.4 mm pilot restrictor
- 1.5** 1.5 mm pilot restrictor

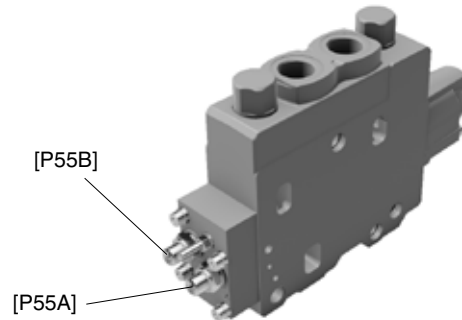

**[P56] Connector type**

- / Spool actuator without connector.
- A** AMP Junior-Timer, mates with type C.
- D** Deutsch, type DT04-2P, mates with DT06-2S.

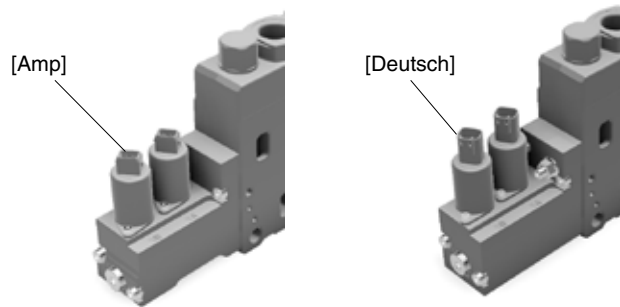

**[P59] Spool actuator variant**

- A010** Supports mechanical spool stroke limitation, and flow setting Qset B [P72] pump-workport B for spool actuator EC2, ECS2 and ECH2.
- A330** Supports mechanical spool stroke limitation, P-A, B-T and flow setting Qset A [P72] for spool actuator EC2, ECS2 and ECH2.

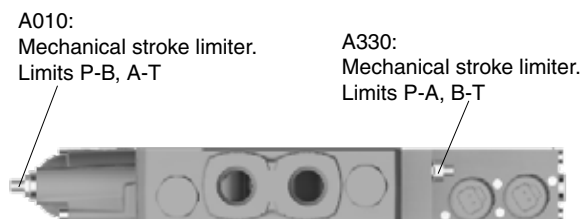

**[P60-P74] Spool selection**

The spool is the most important link between the operator's activation of a lever unit and the movement of the controlled function. For this reason, Parker makes a wide range of standard spools to meet many different function-specific demands. Spools are selected with the aid of a computerised specification program based on a series of different parameters.

**[P60] Spool function**

The spools are available in different basic variants. They are adapted for different flows, load conditions and actuator area ratios. They are also available with different levels of force feedback, see [P64A, B].

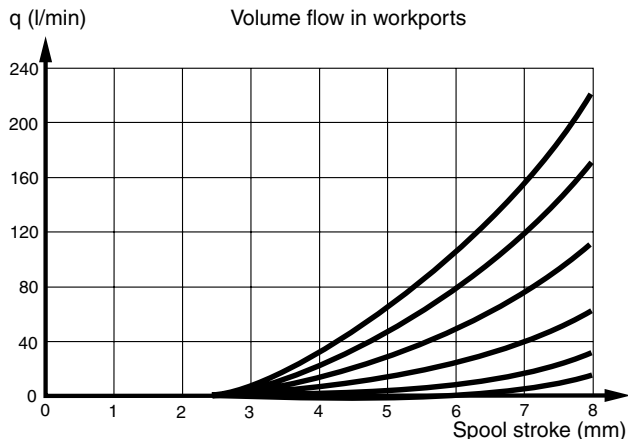

- D** Double-acting spool, e.g. for double-acting cylinders.
- D1** As spool function D, but designed to be combined with an over-centre valve.
- D2** As spool function D, but with the option of mechanical force feedback when workport A is activated.
- DS** As spool function D, but the braced workport to the tank falls at the end of the stroke. Suitable for slewing operations.
- Dm** Double-acting spool with drainage of A to T and B to T, which prevents pressure build up in the workport in the neutral position. The spool can be used as a double-acting spool in combination with an over-centre valve.
- Da** Double-acting spool with drainage of A to T, which prevents pressure build up in workport A in the neutral position. The spool can be used as a double-acting spool in combination with an over-centre valve.
- Db** Double-acting spool with drainage of B to T, which prevents pressure build up in workport B in the neutral position. The spool can be used as a double-acting spool in combination with an over-centre valve.
- EA** Single-acting spool, e.g. for single-acting cylinders. Lifting and lowering functions at workport A.
- EA2** As spool function EA, but with the option of mechanical force feedback when workport A is activated.
- EB** Single-acting spool, e.g. for single-acting cylinders. Lifting and lowering functions at workport B.
- E5** Single-acting spool, e.g. for single-acting cylinders. Lifting and lowering function at both workports A and B.
- M** Double-acting spool, e.g. for hydraulic motor. Floating function in neutral position, connects workport A and B to tank.
- MA** Double-acting spool, e.g. for hydraulic motor. Floating function in neutral position, workport A to tank.
- MB** Double-acting spool, e.g. for hydraulic motor. Floating function in neutral position, workport B to tank.
- CB** Regenerative spool via workport B. The large side of the cylinder is connected to workport B.

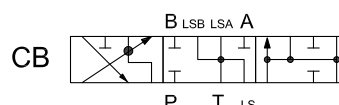
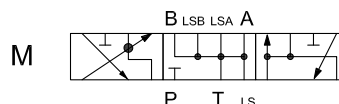
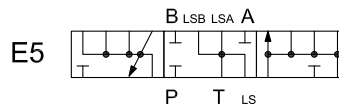
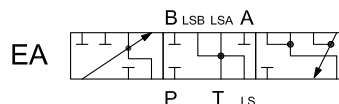
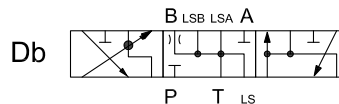
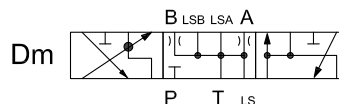
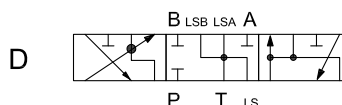

**Work section**

**[P64A, B] Force feedback**

The K220LS is available with force feedback option in individual work sections and individual workports. With force feedback, the operator is better able to sense the increase in machine load, for example when a hard obstacle is met and thereby avoid damage. Force feedback also gives a ramp function, which results in a gentle transitions during speed changes. This results in a stabilizing effect on the hydraulic system, and the machine operating characteristics become smoother. Both these characteristics are important, especially for slewing functions and similar movements. With force feedback, machine wear is reduced and efficiency increases. The section can be equipped with force feedback for workports A and B, individually. The higher the level of force feedback, the greater the reduction in the function's speed when increasing pressure for the same lever stroke. It follows from this that the lever must be moved further in order for the speed of the function to remain the same.

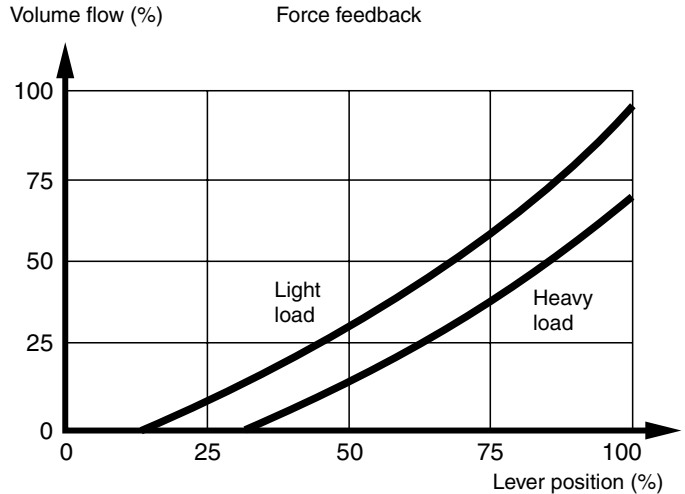

/ No force feedback.

**FF** Hydraulic force feedback. The degree of force feedback depends on choice of pilot restrictors in [P55A, B]. The smaller the diameter of the pilot restrictor is, the greater the degree of force feedback.

**A024** Hydraulic force feedback, as FF, but with a smaller restrictor in the spool.

**FM** Mechanical force feedback on A-side. On B-side, some spools have the option of hydraulic force feedback. Normal degree of force feedback.

**FM+A032** As force feedback FM, but with a low level of force feedback.

**[P66] Pressure compensator and load-hold check valve**

**Pressure compensator and load-hold check valve**

The primary purpose of pressure compensation is to maintain a constant flow rate to a function, regardless of pressure variations in the system.

The load-hold check valve prevents oil passing from the workport to the pump gallery if the pump pressure falls below the load pressure.

**K220LS compensator types:**

K220LS can have two compensator types in the work sections: LS compensators, which provide a fixed, selectable pressure drop over the main spool. If the pump is overdemand, the flow from the section with the highest load pressure is reduced.

AS compensators, which provide a fixed, selectable pressure drop over the main spool based on  $\Delta P$  over the valve. If the pump is overdemand, the flow is reduced for all actuated sections with AS compensators.

If a combination of LS and AS compensators is used, the flow is prioritised for the sections with LS compensators.

**LS compensator types:**

- K1** Fixed pressure compensator with load-hold check valve.
- EK2** Fixed pressure compensator with load-hold check valve. Provides about 20% more flow than K1.
- EK3** Fixed pressure compensator with load-hold check valve. Provides about 55% more flow than K1.
- KN1** Fixed pressure compensator with load-hold check valve. Provides about 5% more flow than K1.
- A077** Function as KN1. Provides about 25% more flow than K1.
- N1** Only load-hold check valve, provides no pressure compensation.
- X1** Section without compensator or load-hold check valve. Prepared for retrofitting of compensator or load-hold check valve.

**AS compensator types:**

- KAS** Compensator for systems with flow distribution. With a pressure difference of 20 bar between PX and LS, the flow to the workports is about 25-40% more than that of a compensator of type K1.
- EKAS** Compensator for systems with flow distribution. With a pressure difference of 20 bar between PX and LS, the flow to the workports is about 65% more than that of a compensator of type K1.

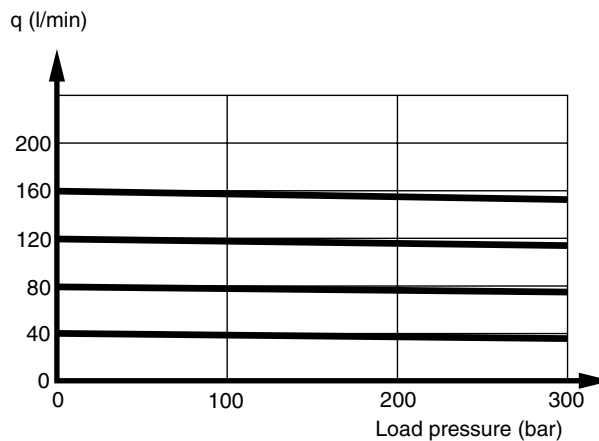

*Load-independent flow with pressure compensator.*

**[P69] Spool designation**

Spool selection is carried out using the configuration program for K220LS.

**[P71A, B] Nominal flow to work port**

Specified at  $\Delta P$  20 bar across the valve for all compensators other than when N1 and X1 are used, in which case the flow information is at  $\Delta P$  15 bar.

**[P72] Flow settings**

With PC and PCH spool actuators, flow limitation over the spool to workports A and B can be effected by means of mechanical limitation of the spool stroke length. By choosing options in [P59], mechanical stroke limitation can be combined with EC2, ECS2 and ECH2.

/ No flow settings.

**Qset** Limitation of maximum flow in workports A and B.

**Qset A** Limitation of maximum flow in workport A.

**Qset B** Limitation of maximum flow in workport B.

**[P72A] Desired set flow**

The desired flow for workport A is entered here.

**[P72B] Desired set flow**

The desired flow for workport B is entered here.

**[P74] Variant for work section**

/ No variant.

**A001** Compensator plug with connection thread G 1/4 or 9/16 UNF-2B allowing tapping of the section load signal controlling the compensator externally. For example, external feed reducer.

**A240** Spool with lower internal leakage from the workport than standard spools.

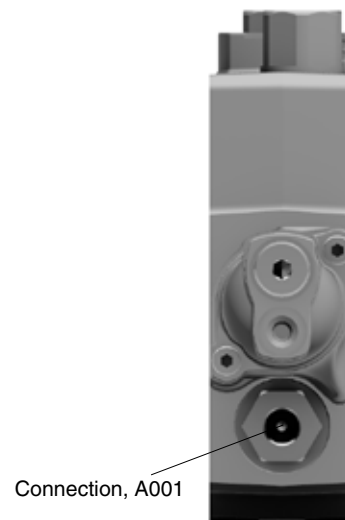



**[P75] Feed reducer valve**

The feed reducer valve is a signal pressure limiter on the load signal.

The signal pressure limiter limits the pressure in the workport by causing the compensator spool to close the pump-workport connection when the signal pressure limiter reaches a preset value. This closes the flow and the function consumes a total of no more than 2 l/min, thereby limiting the pressure with minimal flow/heat loss.

The feed reducer valve cannot handle external pressure peaks, so if they occur, it is recommended to use pressure relief valves in [P76A, B].

**The set pressure in the feed reducer is adjustable.**  
**The set pressure is specified in the relevant workport [P75A], [P75B].**  
**To disable the feed reducer function, select "MAX" in [P75AM], [P75BM]**

- MR** Work section with feed reducer valve for workports A and B. Pressure settings from 30 to 330 bar.
- MRC** Work section with common feed reducer valve for workports A and B, same setting in both ports. The MRC is different on the work sections: Threaded sections PT [P47], adjustable to 30-330 bar. Sections with flange connection FCS, FCH [P47], adjustable between 175-330 bar.
- MRM** Only for a work section with flange connection FC in [P47]. Common feed reduction for workports A and B in the section plus all subsequent sections. Adjustable between 175-330 bar.

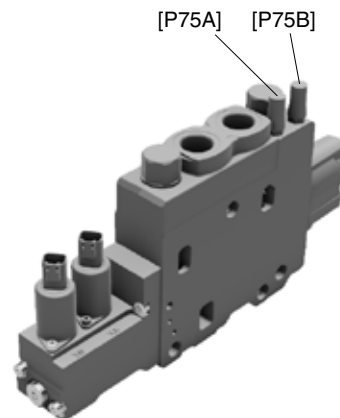

**[P76A, B] Pressure relief and anti-cavitation valves**

The Parker PLC185 is used as a pressure relief valve in the workports of the work sections, protecting from pressure peaks in the PLC185 system and also performing an anti-cavitation function. The PLC185 is a cartridge with a fixed pressure setting. The anti-cavitation valve causes oil to flow from the main tank gallery to the workport side in the event of underpressure in the workports.

**Anti-cavitation characteristics**

The curve shows the pressure drop between tank connection and workport when a pressure relief valve (PA) or anti-cavitation valve (N2) is used.

- X2** Workport open to tank.
- Y2** The connection from the workport to T is blocked with a plug.
- N2** Workport equipped with anti-cavitation valve.
- PA** Pressure relief valve with anti-cavitation function for workport PLC185. Selectable pressure settings in bar: 50, 63, 80, 100, 125, 140, 160, 175, 190, 210, 230, 240, 250, 260, 270, 280, 300, 310, 320, 330, 350 and 365.

**[P85] Side port connection**

Internal connections between workports to adjacent sections or to a function block. The diameter of the side port connection is 8.5 mm so it is not a full flow connection. The aim is to equalise the pressure in sections actuated in parallel, or to transfer a signal to a manifold.

- /** No internal connection between workports.
- M1** Side port connection to previous section (towards the inlet).
- M2** Side port connection to previous and next sections.

**[P89A, B] Workport variant**

- A214** Cavity plug instead of solenoid in EC2/ ECS2/ ECH2 in [P50].

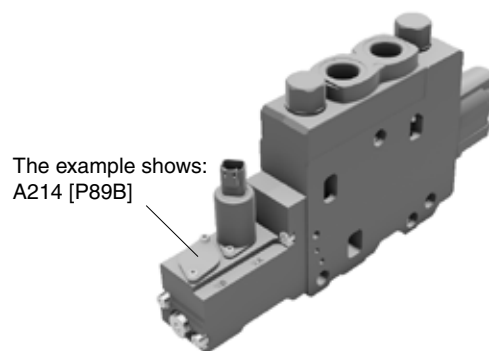
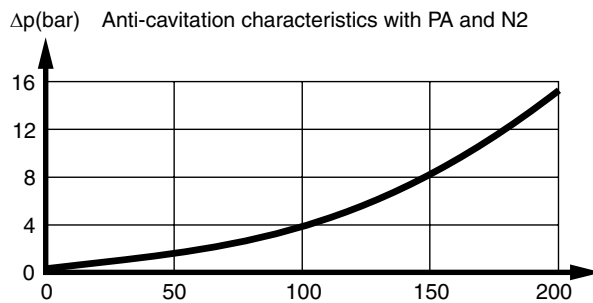
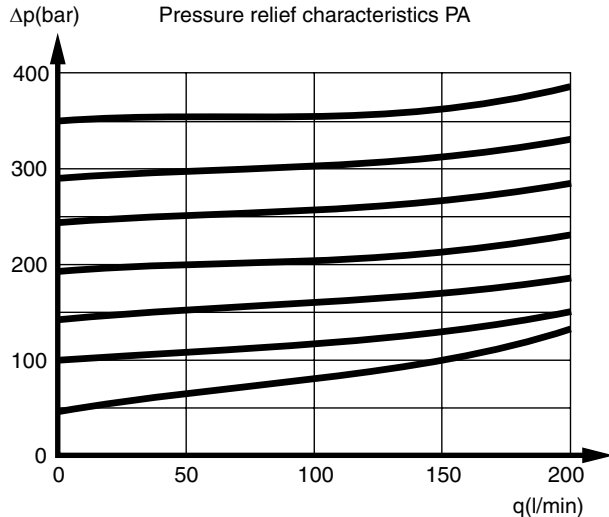

**[P90-P99] Function manifold**

The K220LS can be equipped with a function manifold allowing complete system solutions to be integrated into the valve.

Please contact Parker for more details on integrated system solutions.

**Accessories**

Connectors, levers, etc. are available as accessories. They must be ordered separately.

See our accessories catalogue (MSG17-8558/UK).

**[P50] EC2 manual override**

*Manual override may not be used without knowledge of functionality.*

**CAUTION: No proportional function**

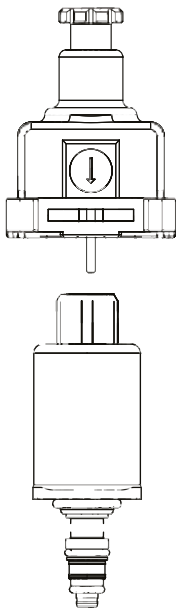

1. A special tool must be used to engage the manual override function of the solenoid! Use of other tools to attempt to engage or disengage the manual override may not work or may not work when intended.
2. When using the manual override function, the solenoid has only on-off functionality and doesn't operate proportionally as usual. This means, for example, that the solenoid may operate much faster than usual and the unexpected speed could cause crushing or other injuries.
3. When using the manual override be certain that all operations of the application, regardless of speed, will not endanger persons or property nearby.
4. As always, consult the operations manual for all specifications and functions of the valve. If there are questions contact MSDE.

The PS25MO is equipped with a manual override pin in the connector. To actuate the PS25MO a specific tool is needed since the tolerances of the pin is so small that it can be damaged or the pin sticks in actuated position.

Please note that it's for fault searching only and shall be used as rarely as possible with common sense in mind. If the manual override is used humans can be exposed to a very dangerous situation. Please read the legal limits before using the manual override.

Part number for override tool: 6763001.

**Dimensional drawing / 3D**

A 3D model and 2D drawing for the current configuration are accessible in Parker's configuration program for K220LS. The drawing shows the maximum external measurement and location of mounting hole. A port table is also included in the drawing.

An example is shown below:

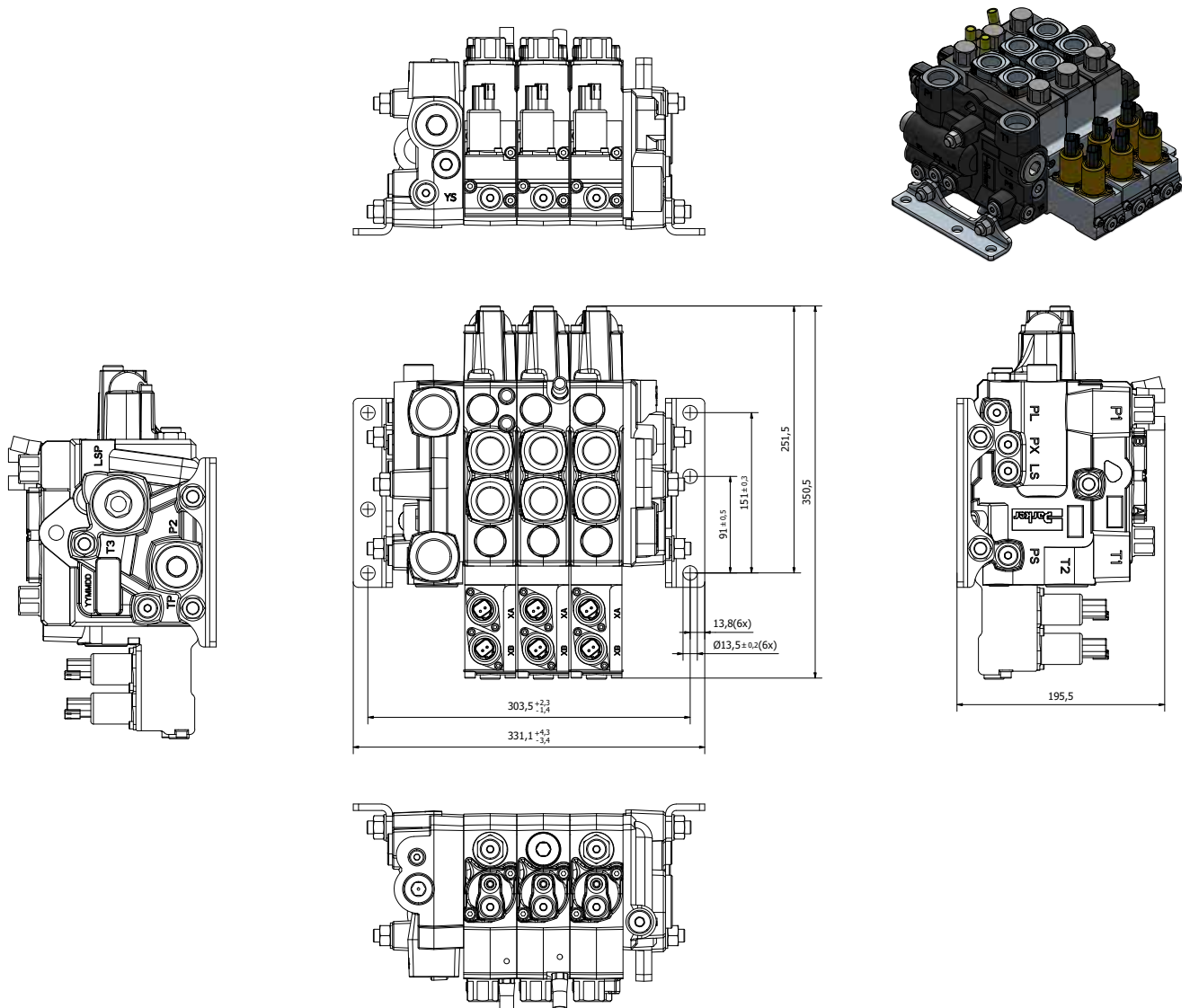

**Spare parts**

Parker's configuration program for K220LS has a Spare part list available for current configuration.

An example is shown below:



**Spare parts list**

Product designation: **K220LS-03-045900-01**

Customer: **Catalogue K220LS**

Application: **Catalogue K220LS**



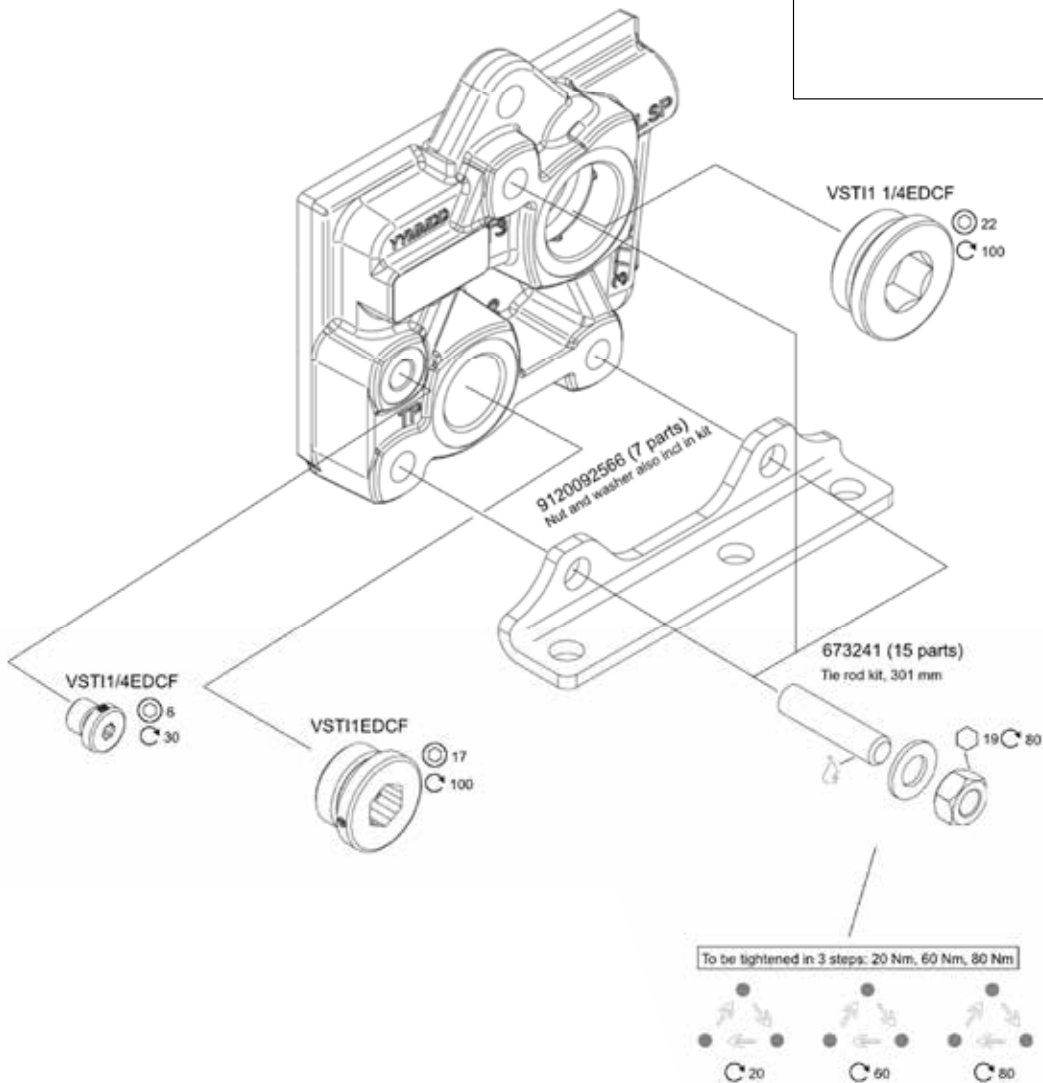



# Parker Worldwide

## Europe, Middle East, Africa

**AE – United Arab Emirates, Dubai**  
Tel: +971 4 8127100  
parker.me@parker.com

**AT – Austria, St. Florian**  
Tel: +43 (0)7224 66201  
parker.austria@parker.com

**AZ – Azerbaijan, Baku**  
Tel: +994 50 2233 458  
parker.azerbaijan@parker.com

**BE/NL/LU – Benelux, Hendrik Ido Ambacht**  
Tel: +31 (0)541 585 000  
parker.nl@parker.com

**BG – Bulgaria, Sofia**  
Tel: +359 2 980 1344  
parker.bulgaria@parker.com

**BY – Belarus, Minsk**  
Tel: +48 (0)22 573 24 00  
parker.poland@parker.com

**CH – Switzerland, Etoy**  
Tel: +41 (0)21 821 87 00  
parker.switzerland@parker.com

**CZ – Czech Republic, Klecany**  
Tel: +420 284 083 111  
parker.czechrepublic@parker.com

**DE – Germany, Kaarst**  
Tel: +49 (0)2131 4016 0  
parker.germany@parker.com

**DK – Denmark, Ballerup**  
Tel: +45 43 56 04 00  
parker.denmark@parker.com

**ES – Spain, Madrid**  
Tel: +34 902 330 001  
parker.spain@parker.com

**FI – Finland, Vantaa**  
Tel: +358 (0)20 753 2500  
parker.finland@parker.com

**FR – France, Contamine s/Arve**  
Tel: +33 (0)4 50 25 80 25  
parker.france@parker.com

**GR – Greece, Piraeus**  
Tel: +30 210 933 6450  
parker.greece@parker.com

**HU – Hungary, Budaörs**  
Tel: +36 23 885 470  
parker.hungary@parker.com

**IE – Ireland, Dublin**  
Tel: +353 (0)1 466 6370  
parker.ireland@parker.com

**IL – Israel**  
Tel: +39 02 45 19 21  
parker.israel@parker.com

**IT – Italy, Corsico (MI)**  
Tel: +39 02 45 19 21  
parker.italy@parker.com

**KZ – Kazakhstan, Almaty**  
Tel: +7 7273 561 000  
parker.easteurope@parker.com

**NO – Norway, Asker**  
Tel: +47 66 75 34 00  
parker.norway@parker.com

**PL – Poland, Warsaw**  
Tel: +48 (0)22 573 24 00  
parker.poland@parker.com

**PT – Portugal**  
Tel: +351 22 999 7360  
parker.portugal@parker.com

**RO – Romania, Bucharest**  
Tel: +40 21 252 1382  
parker.romania@parker.com

**RU – Russia, Moscow**  
Tel: +7 495 645-2156  
parker.russia@parker.com

**SE – Sweden, Borås**  
Tel: +46 (0)8 59 79 50 00  
parker.sweden@parker.com

**SK – Slovakia, Banská Bystrica**  
Tel: +421 484 162 252  
parker.slovakia@parker.com

**SL – Slovenia, Novo Mesto**  
Tel: +386 7 337 6650  
parker.slovenia@parker.com

**TR – Turkey, Istanbul**  
Tel: +90 216 4997081  
parker.turkey@parker.com

**UA – Ukraine, Kiev**  
Tel: +48 (0)22 573 24 00  
parker.poland@parker.com

**UK – United Kingdom, Warwick**  
Tel: +44 (0)1926 317 878  
parker.uk@parker.com

**ZA – South Africa, Kempton Park**  
Tel: +27 (0)11 961 0700  
parker.southafrica@parker.com

## North America

**CA – Canada, Milton, Ontario**  
Tel: +1 905 693 3000

**US – USA, Cleveland**  
Tel: +1 216 896 3000

## Asia Pacific

**AU – Australia, Castle Hill**  
Tel: +61 (0)2-9634 7777

**CN – China, Shanghai**  
Tel: +86 21 2899 5000

**HK – Hong Kong**  
Tel: +852 2428 8008

**IN – India, Mumbai**  
Tel: +91 22 6513 7081-85

**JP – Japan, Tokyo**  
Tel: +81 (0)3 6408 3901

**KR – South Korea, Seoul**  
Tel: +82 2 559 0400

**MY – Malaysia, Shah Alam**  
Tel: +60 3 7849 0800

**NZ – New Zealand, Mt Wellington**  
Tel: +64 9 574 1744

**SG – Singapore**  
Tel: +65 6887 6300

**TH – Thailand, Bangkok**  
Tel: +662 186 7000

**TW – Taiwan, Taipei**  
Tel: +886 2 2298 8987

## South America

**AR – Argentina, Buenos Aires**  
Tel: +54 3327 44 4129

**BR – Brazil, Sao Jose dos Campos**  
Tel: +55 800 727 5374

**CL – Chile, Santiago**  
Tel: +56 2 623 1216

**MX – Mexico, Toluca**  
Tel: +52 72 2275 4200

© 2019 Parker Hannifin Corporation. All rights reserved.

### EMEA Product Information Centre

Free phone: 00 800 27 27 5374

(from AT, BE, CH, CZ, DE, DK, EE, ES, FI, FR, IE, IL, IS, IT, LU, MT, NL, NO, PL, PT, RU, SE, SK, UK, ZA)

### US Product Information Centre

Toll-free number: 1-800-27 27 537

www.parker.com



Your local authorized Parker distributor