

Condition Monitoring and Diagnostic Solutions SensoNODE™ Sensors and Software

Sensors, Software, and Accessories
Catalog 3864 USA | April 2023
PDF Update: November 8, 2024

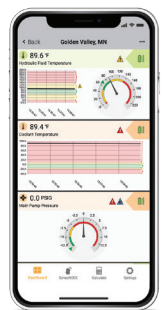

ENGINEERING YOUR SUCCESS.

Quick Coupling Division Locations



Minneapolis, MN



Grantsburg, WI



Chetek, WI



Union City, PA

WARNING

FAILURE OR IMPROPER SELECTION OR IMPROPER USE OF THE PRODUCTS DESCRIBED HEREIN OR RELATED ITEMS CAN CAUSE DEATH, PERSONAL INJURY AND PROPERTY DAMAGE.

- This document and other information from Parker Hannifin Corporation, its subsidiaries and authorized distributors provide product or system options for further investigation by users having technical expertise.
- The user, through its own analysis and testing, is solely responsible for making the final selection of the system and components and assuring that all performance, endurance, maintenance, safety and warning requirements of the application are met. The user must analyze all aspects of the application, follow applicable industry standards, and follow the information concerning the product in the current product catalog and in any other materials provided from Parker or its subsidiaries or authorized distributors.
- To the extent that Parker or its subsidiaries or authorized distributors provide component or system options based upon data or specifications provided by the user, the user is responsible for determining that such data and specifications are suitable and sufficient for all applications and reasonably foreseeable uses of the components or systems.

Offer of Sale

The items described in this document are hereby offered for sale by Parker Hannifin Corporation, its subsidiaries or its authorized distributors. This offer and its acceptance are governed by the provisions stated in the "Offer of Sale."

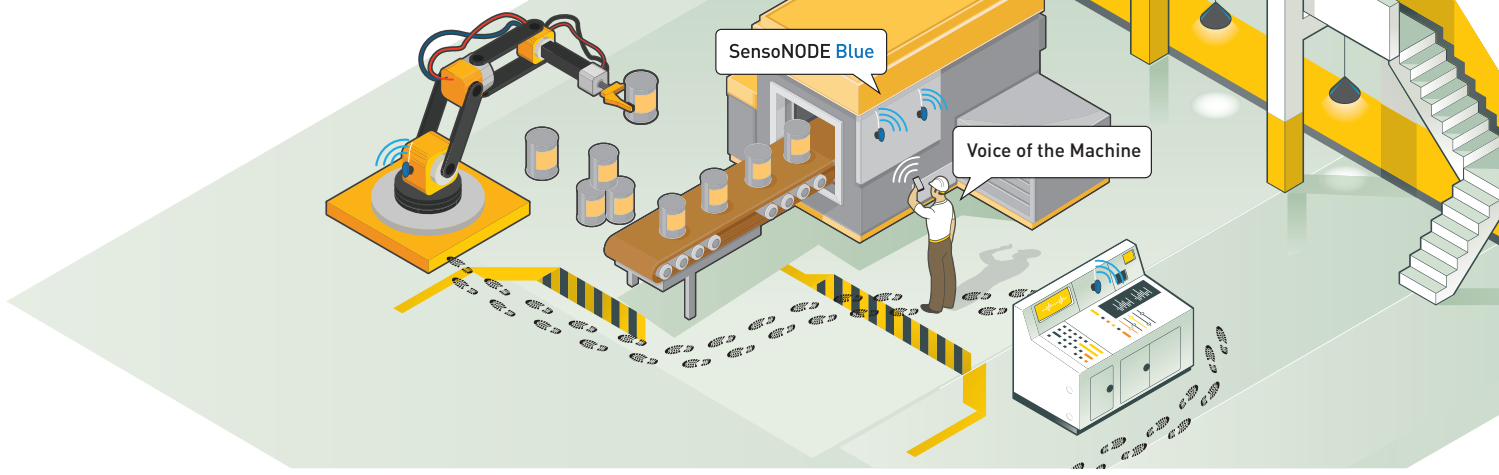
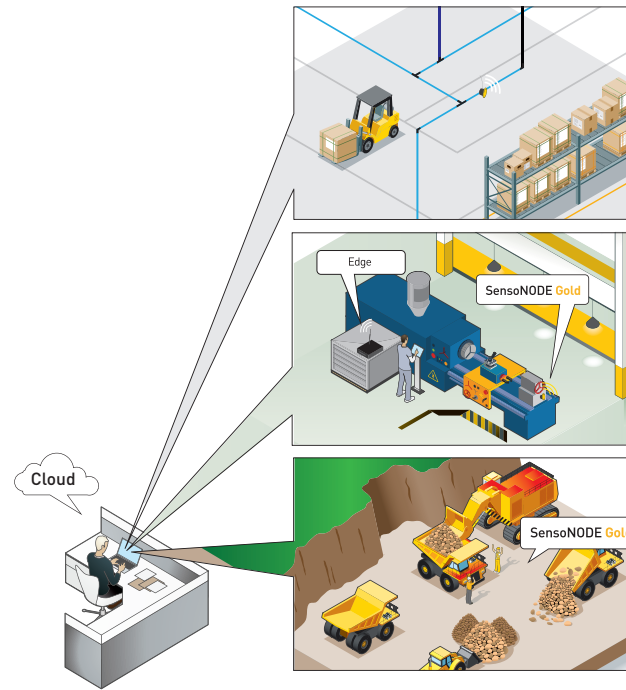

Table of Contents

Introduction	4-5
Product Comparison	6
Route-Based Monitoring - SensoNODE™ Blue	7
Voice of the Machine™ Mobile App	8-10
Pressure Sensors	11-12
Temperature Sensors	13-14
Humidity Sensors	15-16
Analog Connector	17-18
Level Wireless Kit	19-20
Flow Wireless Kit	21-22
ServiceJunior™ CONNECT	23-24
Wired Power Supply	25
Continuous Remote Monitoring - SensoNODE™ Gold	26-27
Voice of the Machine™ Cloud Software	28
Voice of the Machine™ Edge Software	29
Pressure Sensors	30-31
Temperature Sensors	32-33
Humidity Sensors	34-35
Analog Connector	36-37
Voltage Connector	38-39
Current Sensors	40-41
Vibration Sensors	42-43
Pulse Counter	44-45
Level Wireless Kit	46-47
Flow Wireless Kit	48-49
Gateway System	50-51
Wireless Receiver and Repeater	52
Wired Power Supply	53
SensoNODE™ Gold and Voice of the Machine™ Cloud Site Survey Kit	54
Accessories	55
SensoNODE™ Silver Sensors	56
Pressure Sensors	57-58
Offer of Sale	59
Safety Guide	60-61



Parker's IoT-Empowered Solutions

The Internet of Things (IoT) has changed the way manufacturing works, and you can't afford to be left behind. Global competitiveness drives companies to find new ways to improve efficiency and product quality, and incorporating IoT-enabled solutions into your operations ensures your company is moving forward.

Traditional condition monitoring means taking measurements on certain pieces of equipment or processes one at a time, either for diagnostics or performance analysis. While reliable, it can be an inaccurate, labor-intensive process that takes up valuable man-hours and creates potentially dangerous situations for workers...in short; it costs companies time and money.

Parker's **SensoNODE™ Sensors** and **Voice of the Machine™ Software** are IoT-empowered solutions that create new, advanced condition monitoring possibilities to reduce downtime and decrease maintenance costs, helping you to maintain production and improve efficiency.

VOICE OF THE MACHINE™

Voice of the Machine is a centralized strategy to ensure standardization across all Parker IoT-empowered products. Voice of the Machine solutions assure you of component-level IoT that is interoperable, secure, scalable and easy-to-use.

Parker's advanced condition monitoring solutions listen to the Voice of the Machine, allowing you to:

- Reduce your risk, maintenance costs, and unplanned downtime
- Uncover operational and performance improvements
- Make informed, more confident decisions and enjoy greater peace of mind
- Leverage Parker's expertise to employ easy, cost-effective condition monitoring

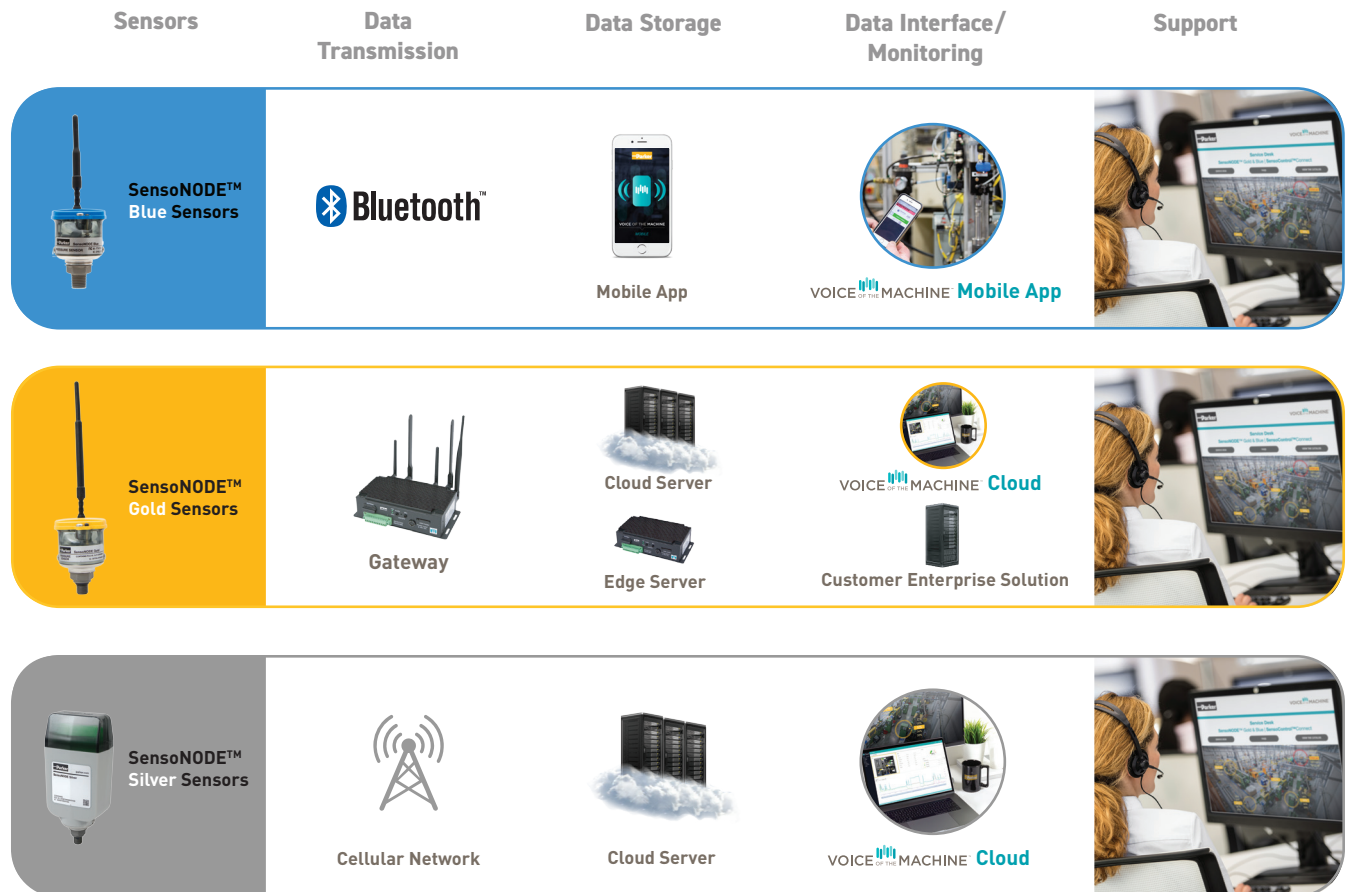

Streamline Your Work with Advanced Condition Monitoring and Diagnostics

Advanced condition monitoring replaces the laborious, time-consuming process of walking from asset to asset, checking manual gauges, taking hand-written notes, and then spending the time to crunch those numbers.

Wirelessly get measurements without interrupting production.

- Identify issues before they escalate
- Reduce downtime
- Decrease maintenance costs
- Avoid dangerous situations
- Make better, more informed decisions
- Improve labor efficiency

When used together, SensoNODE Sensors and Voice of the Machine Software create an advanced condition monitoring solution that delivers vital measurement data to help drive optimal tactical, operational, and strategic decisions, leading to maximum uptime.

Route-Based Monitoring - No network required (SensoNODE Blue and Mobile App)

- Short-term monitoring when you need it
- Aids diagnostic efforts
- Take measurements from individual machines
- Wireless solution for on-site monitoring
- Export recorded measurements

Continuous Remote Monitoring - Network-based (SensoNODE Gold and Silver and Cloud/Edge)

- Long-term and immediate health of machines and processes are viewable around the globe
- Ideal for environments where assets are mission critical, and shutdowns are costly
- User selectable measurement data storage
- Remote solution accessible anywhere, anytime
- Get notified automatically of discrepancies

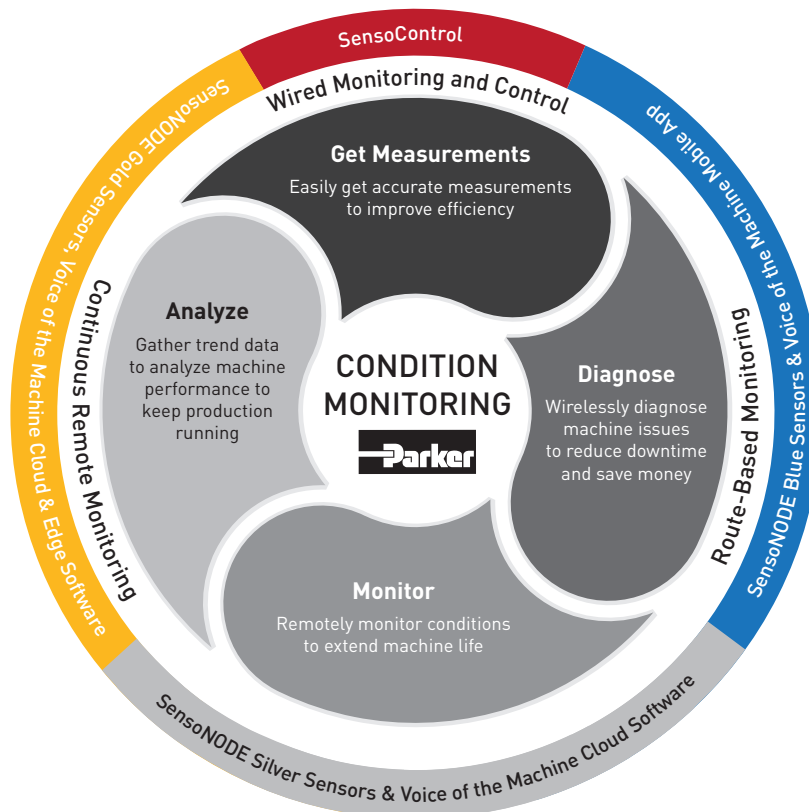

Condition Monitoring Solutions

	SensoControl	SensoNODE Blue and Mobile App	SensoNODE Gold and Edge	SensoNODE Gold and Cloud	SensoNODE Silver and Cloud
Primary Application					
Wireless Continuous Remote Monitoring			√	√	√
Wireless Route-Based Monitoring		√			
Diagnostics	√	√			
Communication Method					
Sub-GHz Wireless			√	√	
Cellular					√
Bluetooth Low Energy (BLE)		√			
Wires	√				
Key Features					
Alert Notifications - Text, Email			√	√	√
In-Use Alarms		√	√	√	√
Export and Share Data	√	√	√	√	√
Recordings	√	√	√	√	√
View Historical Data			√	√	√
Configurable Dashboards		√	√	√	√
Functions or Calculations	√	√	√	√	√
Configurable Units of Measure	√	√	√	√	√
Multiple Visualizations	√	√	√	√	√
Viewable on Multiple Devices		√*	√	√	√
Add Sensors Instantly	√	√	√	√	√
Fastest Measurement Rate	1 millisecond **	1 second	750 milliseconds	15 seconds	20 minutes
Pressure Spike and Drop Capturing	√				
Synchronization of Measurement Inputs	√				
Battery Life	Use Dependent	Rate Dependent	Rate Dependent	Rate Dependent	Rate Dependent
FCC, IC, &/or CE Certified	√	√	√	√	√
Sensor IP Rating	IP67/IP64/IP65***	IP65	See Product Technical Data	See Product Technical Data	See Product Technical Data
Data Storage					
Cloud			√	√	√
Local Server			√		√
Mobile Device		√			
Handheld Meter	√				
Interface					
Desktop/Laptop	√		√	√	√
Mobile App		√			
Handheld Meter	√				
Other					
Software License			√		
Cloud Subscription Required				√	√
Optional Cellular Subscription				√	Mandatory
Internet/WiFi/LAN Required			√	√	
Gateway Required			√	√	
Site Survey Required			√	√	

*In Broadcast Mode Only **0.1ms Available on ServiceMaster+ ***Varies with Handmeters



Route-Based Monitoring and Diagnostics

Parker's route-based monitoring and diagnostics allow workers to take instant measurements of individual assets wirelessly, and record those measurements using their mobile device. Compared to traditional, wired gauges, users spend less time getting measurements, and can avoid potentially unsafe working conditions; e.g. monitoring mobile equipment.

Parker's SensoNODE Blue Sensors and Voice of the Machine Mobile Software deliver an IoT solution where hardware and software work together to provide measurements and diagnostics across multiple applications and industries.

Ideal for quick, accurate diagnostics, SensoNODE Blue and Voice of the Machine help companies:

- Get accurate measurements
- Gather measurements from a distance without interrupting production
- Avoid potentially dangerous situations
- Diagnose issues quickly
- Improve work efficiency
- Share data direct from your mobile device

SensoNODE Blue Sensors and Voice of the Machine Software

SensoNODE Blue is Parker's series of Bluetooth-enabled sensors. Compact, energy-efficient, and wireless, they are designed to provide simple and useful solutions for diagnostic and condition monitoring applications with mobile devices. SensoNODE monitors asset measurements to help predict problems and prevent downtime.

Why Blue?

- Accurate measurements
- Easy installation
- No network required
- Wireless installation removes challenges of wired systems
- No external power source required
- Ultra-low battery consumption for up to five years of battery life*
- Sealed sensor housing ideal for harsh environments
- Compact lightweight design
- LED indicators aid in identifying sensor status

* Not continuous use

Voice of the Machine Mobile App allows users to receive measurements directly to their mobile devices. The app compiles the data and presents it in a way that makes sense to a user's operation allowing them to track data immediately and receive user-defined alarms for unplanned condition changes that may damage assets. Mapping and dashboard functions allow you to customize data visualization.

Why Mobile App?

- Measurements delivered to your mobile device
- Easy-to-use interface
- Customizable dashboards
- Mapping function
- Set your own alarm thresholds of measurements (min/max)
- Alerted when outside of defined thresholds
- Name sensors so they are easily identifiable
- Easy-to-understand trend charts
- Multiple users can access data from their mobile device
- Export data for analysis, sharing, and retention

Mobile App

Voice of the Machine Mobile App is used for diagnostics and condition monitoring for predictive maintenance. The app allows users to connect to Parker's SensoNODE™ Blue wireless sensors to gather measurements for a wide range of fluid and gas applications.

Voice of the Machine Mobile App puts vital information in the palm of the user's hand. It offers immediate and historic trend information collected by SensoNODE™ Blue wireless sensors and presents it in a way that makes sense to a user's operation, providing the information needed to optimize asset performance. Data can also be easily exported and shared.

Voice of the Machine Mobile App alerts users of unplanned condition changes that may damage components and equipment. As levels rise above or fall below user-defined thresholds, users are alerted to these events, giving them an opportunity to address potential issues that could harm the system over time, helping to reduce unplanned downtime and increase productivity.

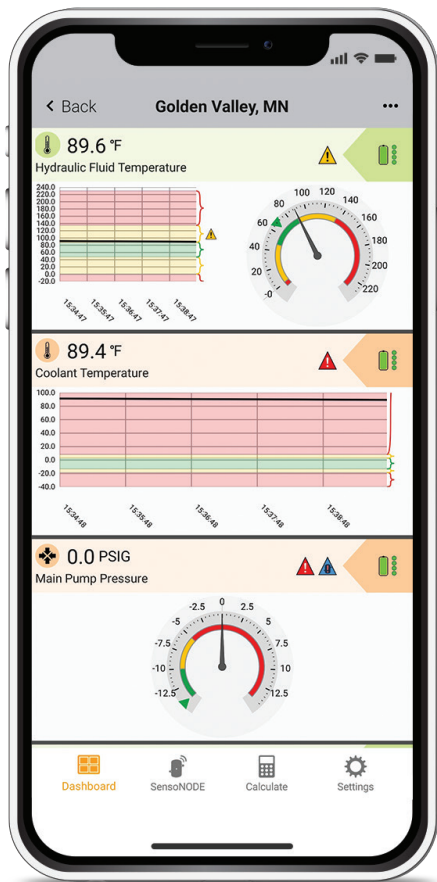

Capabilities:

- Mobile application designed for iOS and Android
- Connect and display SensoNODE Blue Sensors

Features:

- Intuitive design and user experience
- Auto recognition enables users to quickly add and connect multiple sensors concurrently
- Easy readability of measurements with visualized data in digital gauges and trend charts
- View immediate measurements that include current values and minimum/maximum indicators in addition to historical sensor information
- Configurable alarm thresholds with alerts when thresholds are exceeded; monitoring continues while sensors are unattended
- Customizable trend charts and dashboards
- Mapping function for pressure, 4-20mA and flexible displacement sensors that correlates raw measurements into your "specific" units
- Easily export and share data

Voice of the Machine™ Mobile App



Compatibility:

- Requires iOS (10.3 or newer) or Android (6 or newer)

Languages:

- English

Supported Devices:

- iPhone (6S and newer)
- iPad (5th generation and newer)
- Compatible with most Bluetooth Low Energy (BLE) supported Android devices



Sensor Inventory

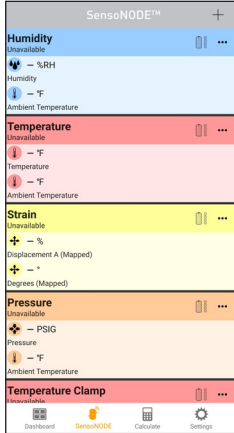

One-touch access to sensors that have been added to your mobile device with their latest measurements, alarm status, and sensor mode - broadcasting or connected.

Measurement Detail

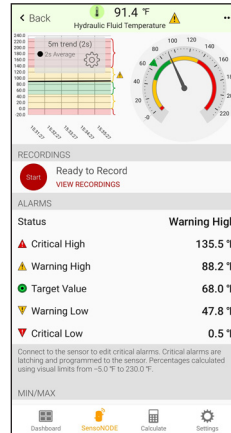

Focus on a single measurement with trend charts, digital gauge, alarm thresholds and other useful features for the operational professional.

Sensor Setup

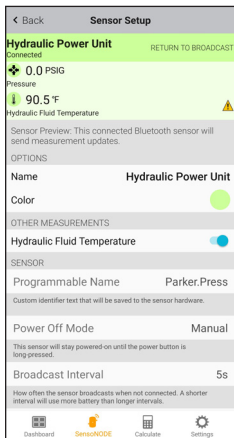

Configure sensors with individually programmed name, highlight color and modes of operation to suit different use cases.

Dashboard

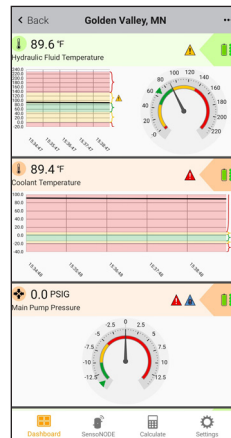

Simplify monitoring activities by grouping measurements that belong together and compare the group's trends and gauges.

Alarm Settings

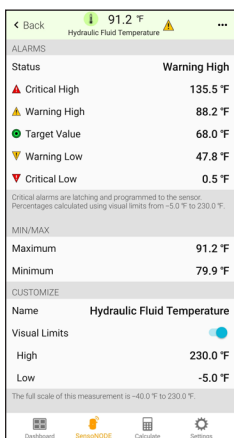

Define measurement thresholds to get notified of important changes. Critical thresholds are programmed to sensor firmware for exception monitoring between readings.

Record and Export

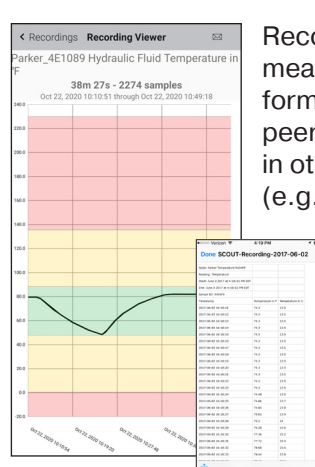

Record and export measurements in CSV format for sharing with peers or further analyzing in other applications (e.g. Excel).



Features:

- Available in a variety of pressure ranges from -14.5 psi to 8700 psi
- User-definable measurement units (psi/bar) for convenient and familiar data readings
- Port options: Male NPT or SAE thread and EMA or PD quick couplers for fast and easy connecting
- Corrosion resistant materials for challenging environments
- Sensor also provides ambient temperature values
- User selectable measurement and broadcast intervals. Refer to Voice of the Machine Mobile App for more information about capabilities and modalities.

Sensor Technical Data							
Housing Material	Polycarbonate	Polycarbonate	Polycarbonate	Polycarbonate	Polycarbonate	Polycarbonate	Polycarbonate
Port	1/4" Male NPT	1/4" Male NPT	1/4" Male NPT	-4 SAE	-4 SAE	-4 SAE	-4 SAE
Wetted Parts Material	17-4 Stainless	17-4 Stainless	17-4 Stainless	17-4 Stainless and Nitrile	17-4 Stainless and Nitrile	17-4 Stainless and Nitrile	17-4 Stainless and Nitrile
Measurement Range (pressure)	-14.5 to 14.5 psi [-1 to 1 bar]	0-150 psi [10 bar]	0-232 psi [16 bar]	0-1500 psi [100 bar]	0-3625 psi [250 bar]	0-5800 psi [400 bar]	0-8700 psi [600 bar]
Max. Overload Pressure	29 psi	225 psi	350 psi	2250 psi	5440 psi	8700 psi	13,050 psi
Burst Pressure	3x	4x	4x	4x	4x	4x	4x
Accuracy (at 77°F / 25°C)	1.5%	1.5%	1.5%	1.5%	1.5%	1.5%	1.5%
Resolution	.01 psi	.1 psi	.1 psi	1 psi	1 psi	1 psi	1 psi
Measurement and Broadcast Interval	User Selectable	User Selectable	User Selectable	User Selectable	User Selectable	User Selectable	User Selectable
Response Time (min)	1 sec	1 sec	1 sec	1 sec	1 sec	1 sec	1 sec
Ambient Temperature* (battery limited)	-4°F to 158°F [-20°C to 70°C]	-4°F to 158°F [-20°C to 70°C]	-4°F to 158°F [-20°C to 70°C]	-4°F to 158°F [-20°C to 70°C]	-4°F to 158°F [-20°C to 70°C]	-4°F to 158°F [-20°C to 70°C]	-4°F to 158°F [-20°C to 70°C]
Fluid Media Temperature Range	-40°F to 185°F [-40°C to 85°C]	-40°F to 185°F [-40°C to 85°C]	-40°F to 185°F [-40°C to 85°C]	-40°F to 185°F [-40°C to 85°C]	-40°F to 185°F [-40°C to 85°C]	-40°F to 185°F [-40°C to 85°C]	-40°F to 185°F [-40°C to 85°C]
Full Range Life Cycles	> 1 million	> 1 million	> 1 million	> 1 million	> 1 million	> 1 million	> 1 million
Certifications	FCC, IC, CE	FCC, IC, CE	FCC, IC, CE	FCC, IC, CE	FCC, IC, CE	FCC, IC, CE	FCC, IC, CE
Battery (Panasonic is recommended brand)	CR123A	CR123A	CR123A	CR123A	CR123A	CR123A	CR123A
IP Rating	IP65	IP65	IP65	IP65	IP65	IP65	IP65

Note: Consult QCD for other port options, pressure ratings, and port seal materials.

*Ambient temperature range can be broadened by installing Wired Power Adapter (SNWP2-B)



Pressure Sensors

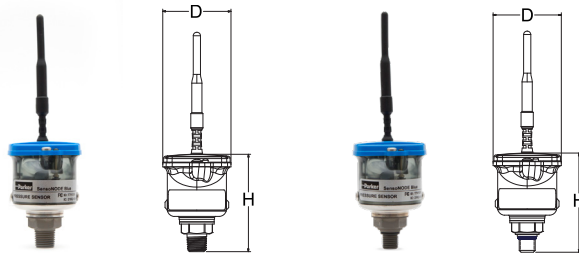

Part Number	Pressure Rating psi [bar]	Port	D	H
SNPT4-1-B-4MP	-14.5 to 14.5 [-1 to 1]	1/4" Male NPTF	ø1.88" [48mm]	2.66" [68mm]
SNPT4-10-B-4MP	0-150 [10]	1/4" Male NPTF	ø1.88" [48mm]	2.66" [68mm]
SNPT4-16-B-4MP	0-232 [16]	1/4" Male NPTF	ø1.88" [48mm]	2.66" [68mm]
SNPT4-100-B-4MO	0-1500 [100]	-4 SAE	ø1.88" [48mm]	2.72" [69mm]
SNPT4-250-B-4MO	0-3625 [250]	-4 SAE	ø1.88" [48mm]	2.72" [69mm]
SNPT4-400-B-4MO	0-5800 [400]	-4 SAE	ø1.88" [48mm]	2.72" [69mm]
SNPT4-600-B-4MO	0-8700 [600]	-4 SAE	ø1.88" [48mm]	2.72" [69mm]

Quick Couplers

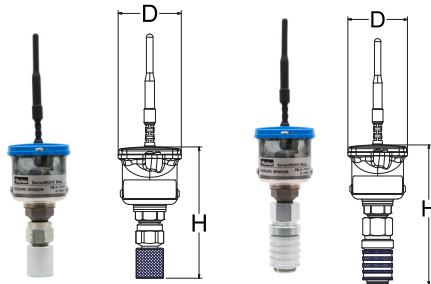

Part Number	Pressure Rating psi [bar]	Port	D	H
SNPT4-100-B-4MO-EMA	0-1500 [100]	EMA	ø1.88" [48mm]	4.00" [101mm]
SNPT4-250-B-4MO-EMA	0-3625 [250]	EMA	ø1.88" [48mm]	4.00" [101mm]
SNPT4-400-B-4MO-EMA	0-5800 [400]	EMA	ø1.88" [48mm]	4.00" [101mm]
SNPT4-600-B-4MO-EMA	0-8700 [600]	EMA	ø1.88" [48mm]	4.00" [101mm]
SNPT4-100-B-4MO-PD	0-1500 [100]	PD	ø1.88" [48mm]	4.40" [112mm]
SNPT4-250-B-4MO-PD	0-3625 [250]	PD	ø1.88" [48mm]	4.40" [112mm]
SNPT4-400-B-4MO-PD	0-5800 [400]	PD	ø1.88" [48mm]	4.40" [112mm]

Note: Products in catalog are currently only for sale in U.S., Canada, and Europe except where stated otherwise.

Temperature Accuracy

How to Order:

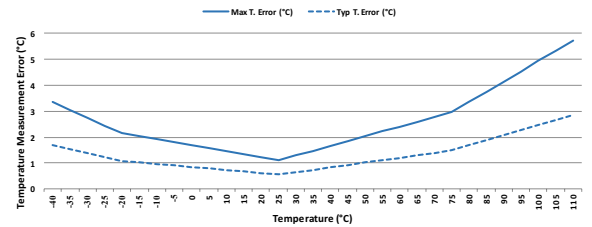
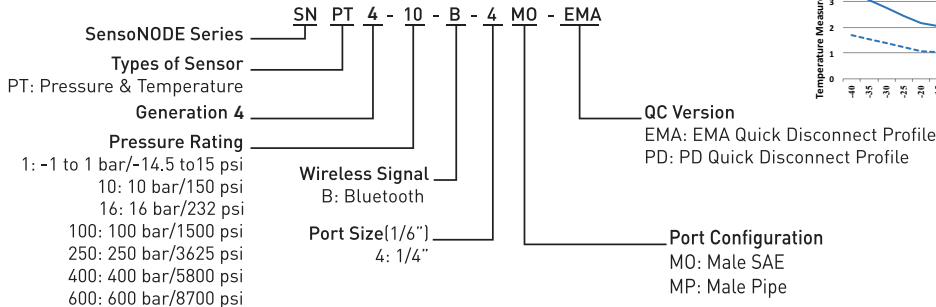







WARNING The products listed can expose you to chemicals including Lead, which is known to the State of California to cause cancer, and to cause birth defects or other reproductive harm. For more information go to www.P65Warnings.ca.gov



Features:

- User-definable measurement units (F°/C°) for convenient and familiar data readings
- Port Options: Male NPTF and SAE
- Corrosion-resistant materials for challenging environments
- User-selectable measurement and broadcast intervals. Refer to Voice of the Machine Mobile App for more information about capabilities and modalities.
- Available in unique foot and clamp designs for quick attachment to pipe or hard tubing

Sensor Technical Data

						
Housing Material	Polycarbonate	Polycarbonate	Polycarbonate	Polycarbonate	Polycarbonate	Nylon
Port	1/4" Male NPTF	-4 SAE	1/4" Male NPTF	-4 SAE	Foot	Clamp
Wetted Parts Material	17-4 Stainless	17-4 Stainless and Nitrile	17-4 Stainless	17-4 Stainless and Nitrile	Stainless	Stainless
Measurement Range (Fluid Temperature)	-40°F to 230°F [-40°C to 110°C]	-40°F to 230°F [-40°C to 110°C]	-40°F to 230°F [-40°C to 110°C]	-40°F to 230°F [-40°C to 110°C]	-40°F to 257°F [-40°C to 125°C]	-40°F to 257°F [-40°C to 125°C]
Working Pressure	0-10k psi [0-700 bar]	0-9k psi [0-630 bar]	0-1500 psi [0-100 bar]	0-1500 psi [0-100 bar]	N/A	N/A
Max. Overload Pressure	3x	3x	2x	2x	N/A	N/A
Burst Pressure	4x	4x	3x	3x	N/A	N/A
Accuracy (at 77°F/ 25°C)	±3.0%	±3.0%	±3.0%	±3.0%	±5.0%	±5.0%
Resolution (from 14°F to 120°F) [-10°C to 44.8°C]	1°F [.56°C]	1°F [.56°C]	1°F [.56°C]	1°F [.56°C]	2°F [1.12°C]	2°F [1.12°C]
Measurement and Broadcast Intervals	User Selectable	User Selectable	User Selectable	User Selectable	User Selectable	Measurement Only (1 sec)
Response Time (minimum)	1 sec	1 sec	1 sec	1 sec	1 sec	1 sec
Ambient Temperature (battery limited)*	-4°F to 158°F [-20°C to 70°C]	-4°F to 158°F [-20°C to 70°C]	-4°F to 158°F [-20°C to 70°C]	-4°F to 158°F [-20°C to 70°C]	-4°F to 158°F [-20°C to 70°C]	-4°F to 158°F [-20°C to 70°C]
Full Range Life Cycles	> 1 million	> 1 million	> 1 million	> 1 million	> 1 million	> 1 million
Certifications	FCC, IC, CE	FCC, IC, CE	FCC, IC, CE	FCC, IC, CE	FCC, IC, CE	FCC, IC, CE
Battery (Panasonic is recommended brand)	CR123A	CR123A	CR123A	CR123A	CR123A	CR2450
IP Rating	IP65	IP65	IP65	IP65	IP65	IP65

Note: Consult QCD for other port options and port seal materials.

*Ambient temperature range can be broadened by installing Wired Power Adapter (SNWP2-B)



Temperature Sensors – Ported

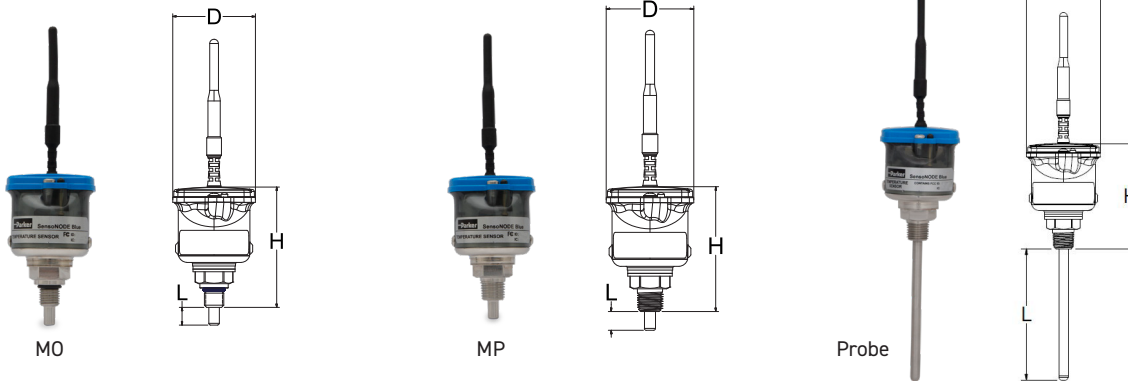

Part Number	Fluid Temperature Range	Port	D	H	L
SNT4-700-B-4MO	-40°F to 230°F [-40°C to 110°C]	-4 SAE	ø1.88" [48mm]	2.72" [69mm]	0.40" [10.16mm]
SNT4-700-B-4MP	-40°F to 230°F [-40°C to 110°C]	1/4" Male NPTF	ø1.88" [48mm]	2.66" [68mm]	0.40" [10.16mm]
SNT4-100-B-4MO-0335	-40°F to 230°F [-40°C to 110°C]	-4 SAE/Probe	ø1.88" [48mm]	2.72" [69mm]	3.35" [85mm]
SNT4-100-B-4MP-0335	-40°F to 230°F [-40°C to 110°C]	1/4" Male NPTF/Probe	ø1.88" [48mm]	2.66" [68mm]	3.35" [85mm]

Temperature Sensors – Foot and Clamp



Part Number	Fluid Temperature Range	L	H	Optimal Clamping
SNT4-0-B-FT	-40°F to 257°F [-40°C to 125°C]	2.42" [61.5mm]	2.31" [58.7mm]	> ø.25" + [>ø6.4mm]
SNT-0-B-CL-KB	-40°F to 257°F [-40°C to 125°C]	5.24" [133.1mm]	3.06" [77.7mm]	ø.25" to ø1.5" [ø6.4mm-ø38.1mm]

Note: Products in catalog are currently only for sale in U.S., Canada, and Europe except where stated otherwise.

Temperature Accuracy

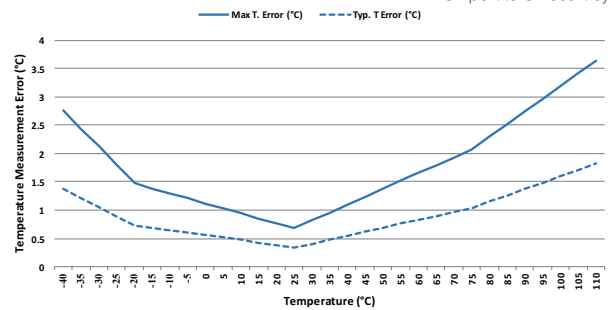

How to Order:

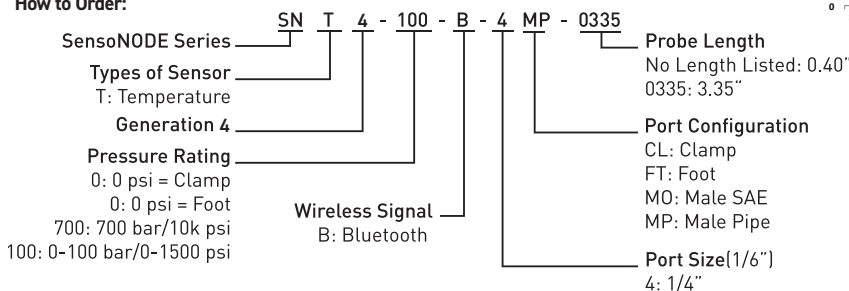

WARNING The products listed can expose you to chemicals including Lead, which is known to the State of California to cause cancer, and to cause birth defects or other reproductive harm. For more information go to www.P65Warnings.ca.gov



Features:

- 0-100% relative humidity
- Ideal for ambient condition and inert compressed gas monitoring applications
- NPTF port to make plumbing and connecting easier and faster
- Optimal mounting orientation is vertical with port facing down to prevent moisture collection
- Sensor also provides gas temperature values
- User-selectable measurement and broadcast intervals. Refer to the Voice of the Machine Mobile App for more information about capabilities and modalities.

Sensor Technical Data

Housing Material	Polycarbonate
Port	1/4" Male NPTF
Wetted Parts Material	Brass, Nitrile, Urethane, and GORE-TEX®
Measurement Range (Humidity)	0-100% RH
Working Pressure	0-150 psi [10 bar]
Max. Overload Pressure	150 psi Max [10 bar]
Burst Pressure	4x
Accuracy (77°F/25°C, 20% RH to 80% RH, at ambient pressure)	±5% RH Max
Resolution (at 77°F/25°C)	0.1% RH
Measurement and Broadcast Interval	User Selectable
Response Time (from 33% to 75% RH)	10 secs
Ambient Temperature (battery limited)*	-4°F to 158°F [-20°C to 70°C]
Temperature Accuracy (from 14°F to 185°F [-10°C to 85°C])	±1.0°F [±0.5°C]
Full Range Life Cycles	> 1 million
Certifications	FCC, IC, CE
Battery (Panasonic is recommended brand)	CR123A
IP Rating	IP65

*Ambient temperature range can be broadened by installing Wired Power Adapter (SNWP2-B)

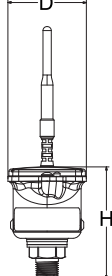

Humidity Sensors				
				
Part Number	RH Range	Port	D	H
SNHT4-10-B-4MP	0-100%	1/4" Male NPTF	ø1.88" [48mm]	2.66" [68mm]

Note: Products in catalog are currently only for sale in U.S., Canada, and Europe except where stated otherwise.

RH Accuracy

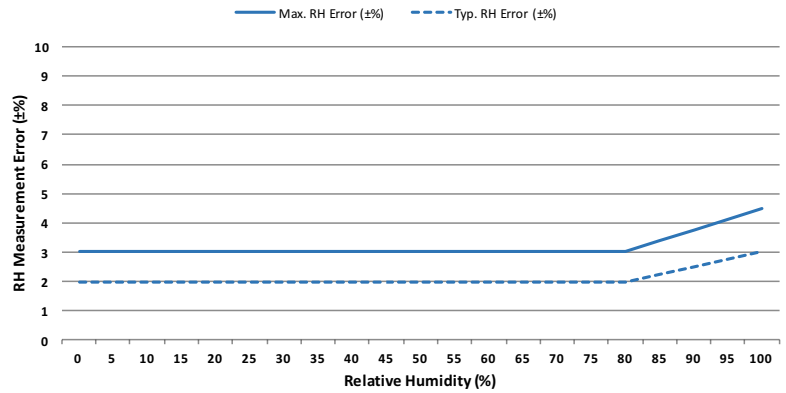

Temperature Accuracy

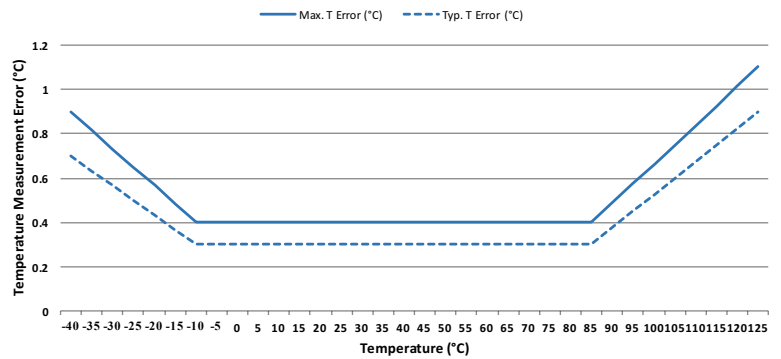

How to Order:

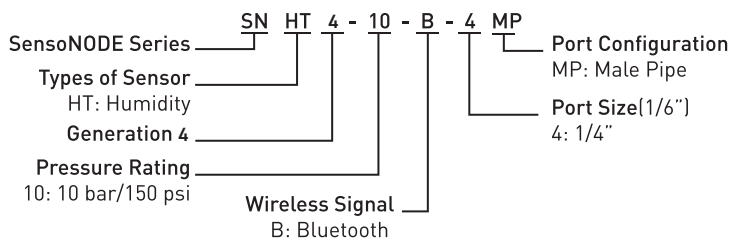

WARNING

The products listed can expose you to chemicals including Lead, which is known to the State of California to cause cancer, and to cause birth defects or other reproductive harm. For more information go to www.P65Warnings.ca.gov



Features:

- Connects inline with any 4-20mA Sensor
- Integrates hardwired sensors into wireless Voice of the Machine Software
- Does not require reprogramming of existing control system
- Magnetic base for tool-free mounting
- Threaded stud port provides alternative mounting options where magnetic base is not suitable
- Definable mapping feature in Voice of the Machine Mobile App to present 4-20mA signal in user defined units
- Requires connection cable SCK-400-xx-xx in conjunction with transmitter and 4-20mA Sensor

Transmitter Technical Data

Base Material	Aluminum
Housing Material	Polycarbonate
Accuracy	0.5% (additive to source)
Resolution	0.1%
Temperature Range with Wired Power	-40 F- 185 F
Temperature Range with Battery	-4 F- 158 F
Measurement and Broadcast Interval	User Selectable
Full Range Life Cycles	> 1 million
Certifications	FCC, IC, CE
Battery (Panasonic is recommended brand)	CR123A
IP Rating	IP65

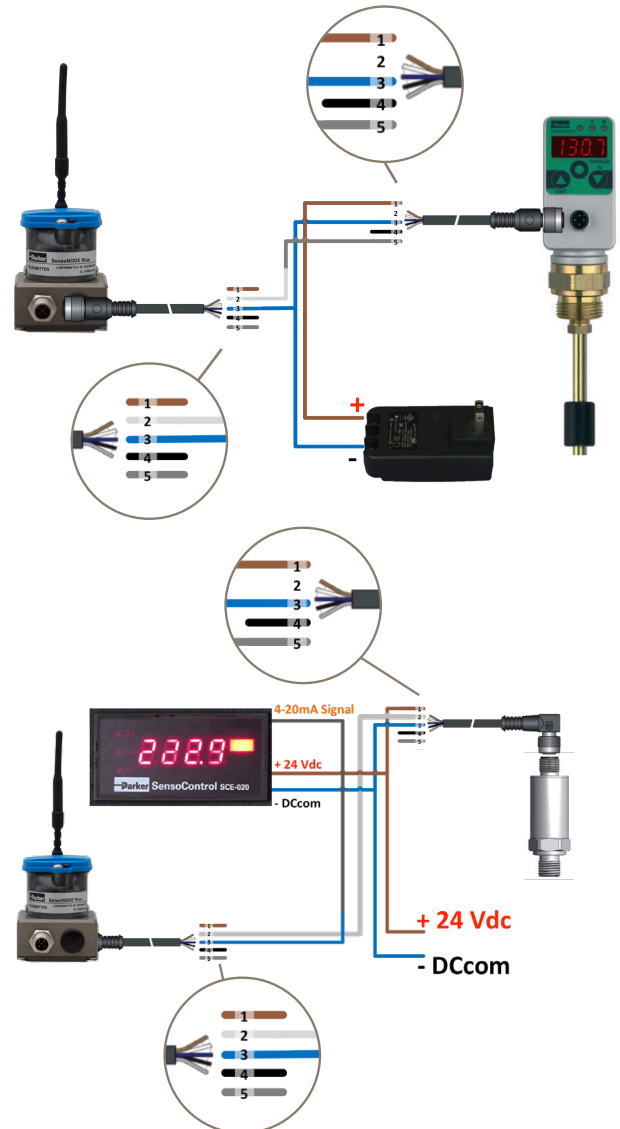

4-20mA Transmitter

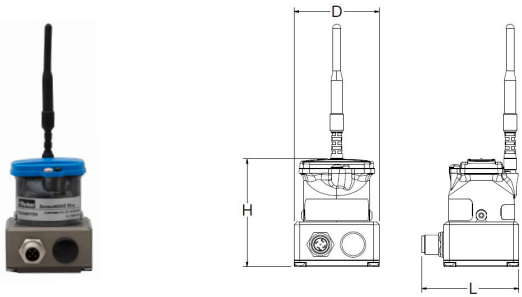

Part Number	Frequency	Base Mounting Thread	D	H	L	Region
SN4204-B	4.2 GHz	1/4-28 UNF x0.45" [11mm]	2.11" [54mm]	2.67" [68mm]	2.41" [61mm]	Worldwide

Note: Products in catalog are currently only for sale in U.S., Canada, and Europe except where stated otherwise.

Pin Assignment

PIN	Connection	Wire Color
1	No Connection	Brown
2	4-20mA Signal In	White
3	4-20mA Signal Out	Blue
4	No Connection	Black
5	No Connection	Gray

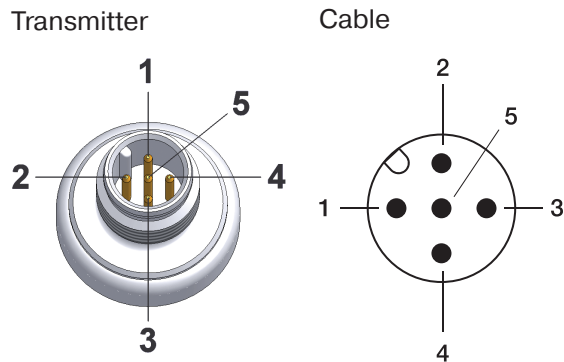

M12 Connection Cable

Part Number	Cable Length	Plug-in Connector
SCK-400-02-45	6.5 ft [2m]	M12 socket, straight
SCK-400-02-55	6.5 ft [2m]	M12 socket, 90
SCK-400-05-45	16 ft [5m]	M12 socket, straight
SCK-400-05-55	16 ft [5m]	M12 socket, 90
SCK-400-10-45	32.5 ft [10m]	M12 socket, straight
SCK-400-10-55	32.5 ft [10m]	M12 socket, 90

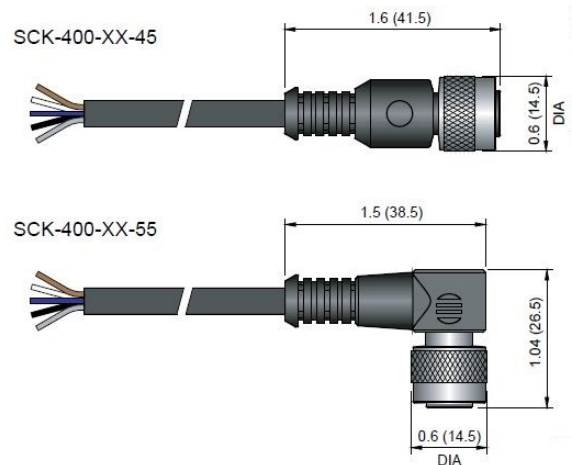

WARNING

The products listed can expose you to chemicals including Lead, which is known to the State of California to cause cancer, and to cause birth defects or other reproductive harm. For more information go to www.P65Warnings.ca.gov



Features:

- Enables local wireless monitoring of fluid level
- Integrates seamlessly with Voice of the Machine Mobile software
- Eliminates necessity for communication cabling
- High visibility level display
- No surge pipe necessary
- Two switching outputs for independent process control

Kit Technical Data ¹					
SNCLSD4-KIT-	250	370	520	800	1000
Sensor length measurement range [inches (mm)]	9.8 (250)	14.6 (370)	20.5 (520)	31.5 (800)	39.4 (1000)
Active range [inches (mm)]	1.6 to 8.3 (40 to 210)	1.6 to 13 (40 to 330)	1.6 to 18.9 (40 to 480)	1.6 to 30 (40 to 760)	1.6 to 37.8 (40 to 960)
Increment size [inches (mm)]	0.2 (5)	0.2 (5)	0.2 (5)	0.4 (10)	0.4 (10)
Lowest reset point RSP [inches (mm)]	1.6 (40)	1.6 (40)	1.6 (40)	1.6 (40)	1.6 (40)
Largest switching value SP [inches (mm)]	8.3 (210)	13 (330)	18.9 (480)	30 (760)	37.8 (960)

Level Controller Technical Data ¹	
Input Parameters	
Measuring Component	Resistance reed chain with float
Connector thread	G3/4 BSPP; nickel-plated brass: ED soft seal NBR ²
Wetted Parts	Brass; nickel-plated brass, NBR ²
Fluid temperature range	-4 to 185°F
Media compatibility	Water; lubricating oil; hydraulic oil
Output Values	
Switching point accuracy	±1% FS at 77°F
Controller Display accuracy	±1% FS ±1 digit at 77°F
Response speed	≤700 ms
Controller resolution	0.3 inches
Float	
Material	NBR
Dimensions	Ø 0.7 inches, length 1.4 inches
Level Rod	
Material	Stainless Steel
Dimensions	Ø 0.3 inches
Operating pressure	14.5 psi

Transmitter Technical Data ³	
Base Material	Aluminum
Housing Material	Polycarbonate
Accuracy	0.5% (additive to source)
Resolution	0.1%
Ambient temperature (battery limited)	-4 to +158°F
Radio Certifications	FCC, IC, CE
Battery [Panasonic is recommended]	CR123A
IP Rating (Transmitter only)	IP65

¹Consult Parker Catalog 4083 for additional level controller details & data

²Different sealing material (FKM, EPDM, etc) upon request

³Consult Analog Transmitter portion of Parker Catalog 3864 for additional details

How to Order:

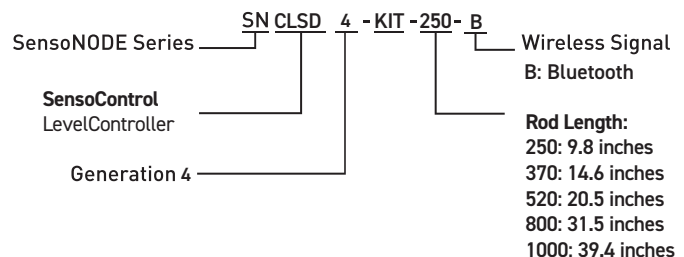



Technical Data	
	<p>Analog Transmitter (SN4204-B)</p> <p>The transmitter wirelessly communicates the analog signal output from the controller to the gateway receiver for monitoring the fluid level of common tanks.</p>
	<p>LevelController (SCLSD-xxx-10-05)</p> <p>The LevelController combines the functions of a level switch, a level sensor and a level display. The LevelController is ideal for the monitoring of fluid level contents. The parameters are set using the keys or over a programming module.</p>
	<p>Mating Cable (SCK-WH-02-45-02)</p> <p>This connection cable (2 meter length) is uniquely designed to connect the analog signals from the controller to the wireless transmitter and switch outputs while also allowing the supply of sufficient voltage needed to power the controller.</p>
	<p>Power Lead (SCK-400-02-45)</p> <p>Connect this cable (2 meter length) via M12 plug to the mating cable to supply voltage to the system. A 15 to 30Vdc supply is required and can be provided via flying leads from the factory DC power or the included 24Vdc power supply included within kit.</p>
	<p>Power Supply (SCSN-240)</p> <p>Provided as an easy solution to supply the appropriate voltage to the wireless kit system. Connect the appropriate Power Leads to corresponding terminals of power supply.</p> <p>Input Voltage: 90~264 VAC Output Voltage: 24Vdc</p>

Flying Lead Wire Diagram for Level Kit (SCK-400-02-45)

PIN	Connection	Wire Color
1	V Supply	Brown
2	S2 out	White
3	0 V/GND	Blue
4	S1 out	Black
5	No Connection	Gray

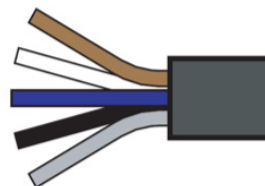

The products listed can expose you to chemicals including Lead, which is known to the State of California to cause cancer, and to cause birth defects or other reproductive harm. For more information go to www.P65Warnings.ca.gov



Features:

- Enables local wireless monitoring of hydraulic flow
- Integrates seamlessly with Voice of the Machine Mobile software
- Eliminates necessity for communication cabling
- Turbine-based measurement
- Measurement range 1 to 800 gpm
- Low flow resistance
- Capable of reverse flow measurement

Kit Technical Data ¹						
SNCFT4-KIT-	015	060	150	300	600	800
Flow Measuring Range: lpm (gpm)	0.25 to 4 (1 to 15)	0.8 to 16 (3 to 60)	1.3 to 40 (5 to 150)	2 to 80 (8 to 300)	4 to 160 (15 to 600)	5 to 210 (20 to 800)
Accuracy (±%) FS/IR @ 21cSt.	± 1 % FS	± 1 % IR	± 1 % IR	± 1 % IR	± 1 % IR	± 1 % IR
Operating Pressure Pn [psi (bar)]	5000 (350)	5000 (350)	5000 (350)	5000 (350)	4200 (290)	5800 (400)
Ports (A-B)	G1/2 BSPP	G3/4 BSPP	G3/4 BSPP	G1 BSPP	G1-1/4 BSPP	1-7/8 UNF
Pressure Drop ΔP [psi (bar)] @ (FS)	21 (1.5)	21 (1.5)	21 (1.5)	58 (4)	58 (4)	72 (5)
Weight [lbs (g)]	1.5 (700)	3.5 (1600)	3.5 (1600)	3.7 (1700)	6 (2700)	11 (5000)

Flow Turbine Technical Data ¹	
Accuracy	
Response time	50 ms
Thermal drift	±0.05 % FS/°C
Repeat accuracy	±0.5 % FS
Resistance to pressure	
Qmax (gpm)	Qn × 1.1
Overload pressure Pmax	Pn × 1.2
Material	
Flow Turbine Housing	Aluminum
Seal	FKM
Wetted Path	Aluminum, steel, FKM
Ambient Conditions	
Ambient temperature	+50 to +122°F
Storage temperature	-4 to +176°F
Tmax Fluid	-4 to +176°F
Filtration	25 μm (10 μm for SNCFT2-004)
Viscosity	15 to 100 cSt.
Protection Class	IP66

Transmitter Technical Data ²	
Base Material	Aluminum
Housing Material	Polycarbonate
Accuracy	0.5% (additive to source)
Resolution	0.1%
Ambient temperature (battery limited)	-4 to +158°F
Radio Certifications	FCC, IC, CE
Battery [Panasonic is recommended]	CR123A
IP Rating (Transmitter only)	IP65

¹Consult Parker Catalog 4083 for additional flow block details & data

²Consult Analog Transmitter portion of Parker Catalog 3864 for additional details

How to Order:

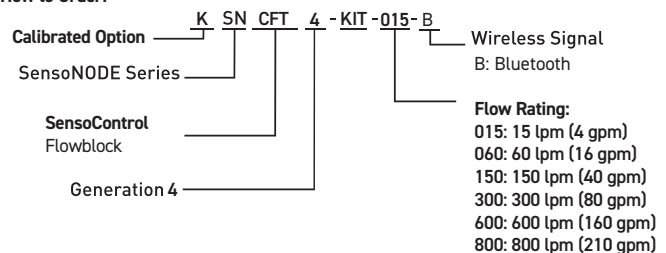



Technical Data	
	<p>Analog Transmitter (SN4204-B)</p> <p>The transmitter wirelessly communicates the analog signal output from the flow turbine to the gateway receiver for monitoring the condition of common hydraulic systems.</p>
	<p>Flow Turbine (SCFT-xxx-22-07)</p> <p>The turbine wheel is driven by the oil flow. The generated frequencies are processed through the digital electronics and influences from the disturbing flow effects are compensated for. Because of the low flow resistance Q_R, the hydraulic circuit operates with very low losses.</p> <p>Reverse operation is also possible because of the special vane (winged) design – so the turbine can be operated in both directions.</p> <p>The turbine casing also includes two plugged 7/16-20UN SAE ORB ports to add additional wireless pressure or temperature sensors directly in the oil flow. More details in Catalog 4083 pages 35-38. https://www.parker.com/content/dam/Parker-com/Literature/HPCE/New/CAT-4083-UK.pdf</p>
	<p>Mating Cable (SCK-WH-02-45-01)</p> <p>This connection cable (2 meter length) is uniquely designed to connect the analog signals from the flow turbine to the wireless transmitter while also allowing the supply of sufficient voltage needed to power the flow block.</p>
	<p>Power Lead (SCK-400-02-45)</p> <p>Connect this cable (2 meter length) via M12 plug to the mating cable to supply voltage to the system. An 18 to 30Vdc supply is required and can be provided via flying leads from the factory DC power or the included 24Vdc power supply within kit.</p>
	<p>Power Supply (SCSN-240)</p> <p>Provided as an easy solution to supply the appropriate voltage to the wireless kit system. Connect the appropriate power leads to corresponding terminals of power supply.</p> <p>Input Voltage: 90~264 VAC Output Voltage: 24Vdc</p>

Flying Lead Wire Diagram for Flow Kit (SCK-400-02-45)

PIN	Connection	Wire Color
1	V Supply	Brown
2	No Connection	White
3	0 V/GND	Blue
4	No Connection	Black
5	No Connection	Gray

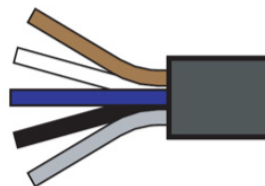

WARNING

The products listed can expose you to chemicals including Lead, which is known to the State of California to cause cancer, and to cause birth defects or other reproductive harm. For more information go to www.P65Warnings.ca.gov

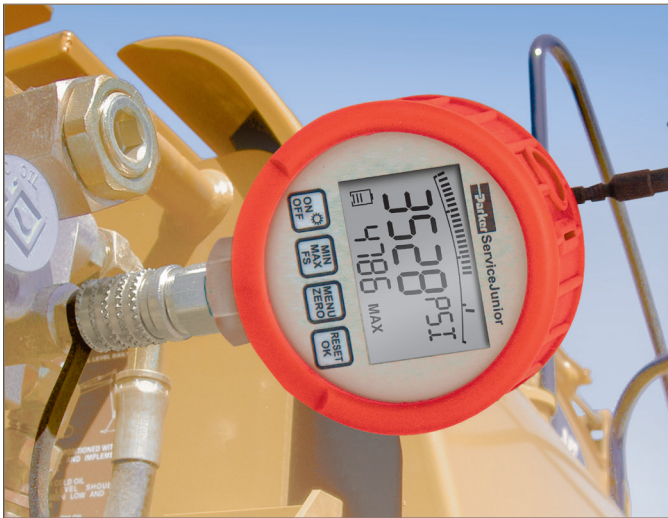

Features:

- Wireless remote readings
- Easy operation
- Hand-held digital pressure gauge
- Measure and display - pressure
- Backlit display
- User-adjustable pressure units
- Min/Max memory
- Battery life indicator
- Ranges for hydraulics and pneumatics
- Scanning rate of 10ms
- Fluid temperature: -4 F to 176 F
- Certifications: FCC, IC, CE

Cover Color Code	
Blue	-14.5 to 230 psi (-1 to 16 bar)
Green	0 to 1500 psi (0 to 100 bar)
Orange	0 to 5800 psi (0 to 400 bar)
Red	0 to 8700 psi (0 to 600 bar)

Digital pressure monitoring

- Capture minimum/maximum pressure changes at a rate of 10 ms
- Digital readout more accurate than mechanical
- Exportable records and proof-of-work statements
- Set alarms, create/view trend graphs, create asset records

Wireless operation

- Powered by Industrial Mobile Software
- Fast accurate readings
- No more wiring or hoses getting caught in machinery
- Line of sight is not needed to obtain measurement
- Allows users to be away from machinery while in use and under full load, reducing safety risks

Scalable and expandable

- Increase or decrease the total number of gauges used
- No need to reconfigure wired infrastructure
- Works with SensoNODE™ Blue Sensors via Mobile App





ServiceJunior CONNECT

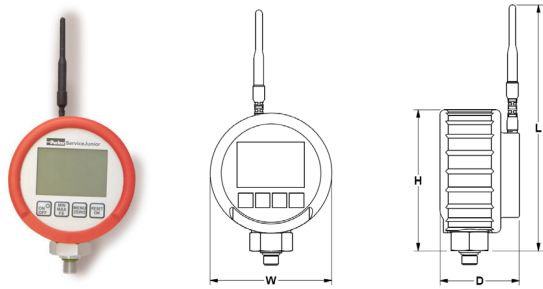

ServiceJunior CONNECT (PD Coupler*)	ServiceJunior CONNECT (EMA3 Coupler**)	ServiceJunior CONNECT (1/4" NPT Port)	Measuring Range	Overload Pressure (psi)	Resolution (psi)	Accuracy
SCJN-016-01-PD-BLE2	SCJN-016-01-BLE2	SCJN-016-01-4MP-BLE2	-14.5 to 230 psi (-1 to 16 bar)	460	0.1	0.5% FS
SCJN-100-01-PD-BLE2	SCJN-100-01-BLE2	SCJN-100-01-4MP-BLE2	0 to 1500 psi (0 to 100 bar)	2,900	1	0.5% FS
SCJN-400-01-PD-BLE2	SCJN-400-01-BLE2	SCJN-400-01-4MP-BLE2	0 to 5800 psi (0 to 400 bar)	11,600	1	0.5% FS
SCJN-600-01-PD-BLE2	SCJN-600-01-BLE2	SCJN-600-01-4MP-BLE2	0 to 8700 psi (0 to 600 bar)	14,500	1	0.5% FS

Product Dimensions	W	D	H	L
ServiceJunior CONNECT	3.52" [89.40mm]	2.28" [57.91mm]	4.04" [102.61mm]	7.05" [179.07mm]

Note: Products in catalog are currently only for sale in U.S., Canada, and Europe except where stated otherwise.

Battery life is dependent upon wireless transmission rate:
 1 second rate = 100 hours of battery life 2 second rate = 200 hours of battery life

* PD Couplers rated to 6,000 psi max

** EMA3 Couplers rated to 9,000 psi max

Note: To receive ServiceJunior with calibration certificate, add K- to the beginning of the part number. (i.e. K-SCJN-016-01-PD-BLE2)

Accessories

Part Number	Description
SCC-300	Storage case for three gauges and diagnostic adapters
SMA3-400CF	16" (400 mm) Hose assembly for EMA M16X2.0 interface
SCA-1/4-EMA-3CF	1/4-19 BSPP female to M16x2.0 EMA3 female swivel
PDH-19	19" PD Hose extension to be used with PD nipple
PDH-32	32" PD Hose extension to be used with PD nipple
PD248	PD Series Diagnostic Coupler with 1/4-19 BSPP thread
1/4X1/4FHG4S	1/4-19 BSPP female to 1/4" NPT male adapter, available from TFD



The products listed can expose you to chemicals including Lead, which is known to the State of California to cause cancer, and to cause birth defects or other reproductive harm. For more information go to www.P65Warnings.ca.gov

**Features:**

- Supplies continuous power to sensors
- Used with IEC/UL 508 Class 2 power supply
- Easy upgrade eliminates the need for battery replacement
- Extends temperature operating range over batteries
- FCC, IC, and CE certified when used with SensoNODE products

Technical Data

Part Number	SNWP2-B
Wire Length	9.8 ft [3m]
Temperature Range	-40 F- 185 F
Input Power	5-36 Volts DC
Output Power	3 Volts DC
Connection	Flying lead 24 AWG Wires
Form	CR123A Battery

**WARNING**

The products listed can expose you to chemicals including Lead, which is known to the State of California to cause cancer, and to cause birth defects or other reproductive harm. For more information go to www.P65Warnings.ca.gov

Continuous Remote Monitoring



Eliminating the downtime of value-generating assets is the most productive method for increasing profit margins. This simplistic concept is the greatest challenge facing manufacturers in the age of Factory of the Future. Freeing labor resources to perform tasks which require a human touch is vital to maintain a competitive edge.

Accessing machine data through live dashboards, receiving alerts of impending failures, performing triage through historical data inspection are high-value actions made possible through cloud computing.

Communicating bi-directionally with controls network devices, customized cloud interfaces, and time series databases through a vast choice of communication protocols is how further integration and value are derived from edge computing.

Wireless communication has made collecting machine data significantly more cost effective. Without the need to run cables and conduit, budgetary resources can be allocated to data collection hardware, further increasing the intelligence of facility operations. Secure data transmission is capable via a rapid installation process which creates minimal demand on maintenance and engineering departments.

SensoNODE Gold and Voice of the Machine Software

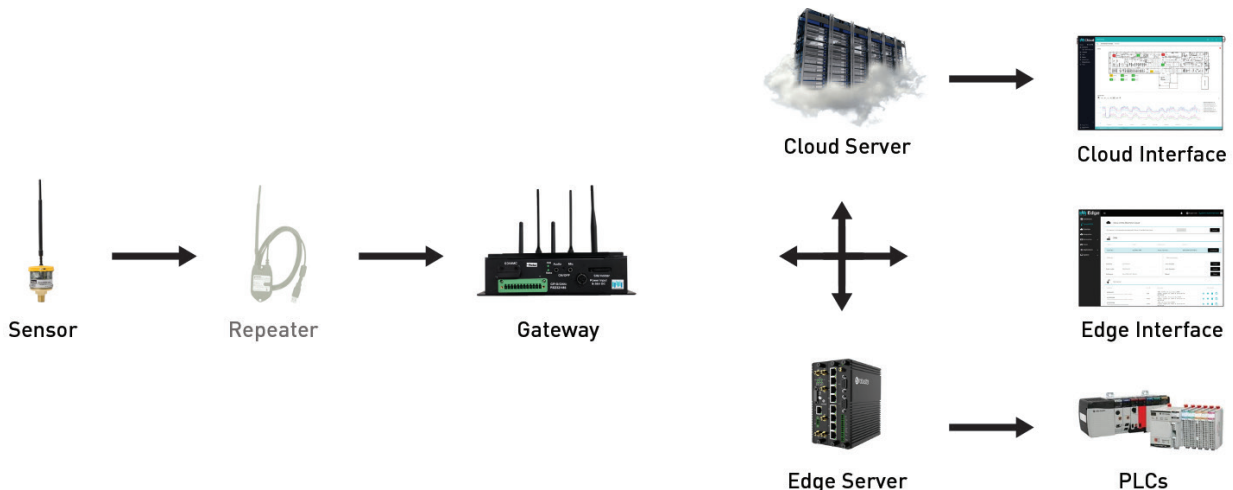

SensoNODE™ Gold Sensors and Voice of the Machine™ Software

Voice of the Machine Cloud

Cloud-based software interface provides flexible organizational structure. Easy enough to visualize a single sensor. Robust enough to present unlimited customers, locations, assets, sensors, and signals in an easily digestible format.

- Customizable dashboards
- Email / SMS alerts
- Gateway statistics
- Historical graphing
- Kiosk display mode
- Live measurements
- OEM cloud instances
- Sensor battery levels
- Templating capabilities
- Wireless signal strengths

Voice of the Machine Edge

Gateway software which speaks numerous IoT protocols to communicate with existing in-plant infrastructure using a topic structures. Node-RED style graphical programming interface enables sophisticated data manipulation and formatting.

- 3rd party cloud connectivity
- 3rd party controller connectivity
- Easily scalable
- FTP server
- JSON configurable functions
- Marketplace for 3rd party applications
- No internet connection needed
- OPC server and client
- Parsable data strings
- Remotely accessible

SensoNODE™ Gold

Our wireless sensors talk with our (required) gateway to collate measurements and send the data to the desired location. Our gateway can receive data from any SensoNODE Gold sensor, most third-party wired sensors with a 4-20mA or a 0-24V output with the help of our transmitters, or other controls network equipment (e.g. Programmable Logic Controllers (PLCs)) via TCP, RTU, or other communication protocols. Each gateway can communicate with up to 250 of our sensors wirelessly.

The wireless sensors (centered at 908MHz) communicate directly to the gateway only. The sensors are IP65 rated. They require a CR123A battery, which typically last 3-5 years, dependent on report rate and environmental conditions. Their wireless range is up to 1,000 ft (line of sight). The antenna emits a omnidirectional signal, in the shape of a donut.

Repeaters may be inserted into the system to extend the range of the sensors. The repeaters can operate in parallel, but not in series with each other. Repeaters require a 120V / 60Hz power supply. Repeaters can extend the range of up to 500 sensors.

Should you not see a pressure range which satisfies your needs, do not see a port configuration which you require, or foresee a unique use-case which requires insight and experience to achieve success, please contact us. We are happy to work with your team to create custom configurations.

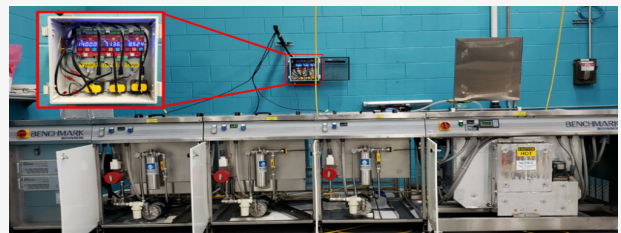

Voice of the Machine Cloud Interface

The cloud interface is ideal for continuously remotely monitoring crucial applications for long periods of time. The web-based console allows users to remotely retrieve data from anywhere. Dashboards with live and historical data provide insight into previously hidden processes, and staff can be alerted to impending failure events.

Wireless sensors integrated into assets collect vital measurement data and send it to the on-site gateway, which pushes the desirable data to the cloud. Users access that data by logging in through a web browser anywhere they have an internet connection. The interface allows users to monitor and collect data from multiple assets and receive alerts of predetermined deviations.

Increased awareness of processes and assets frees users from being on-site to review data to optimize machine performance, extend service life, maintain production quality and reduce downtime.

Applications:

- Robot joints (vibration)
- Baghouse filters (differential pressure)
- Material conveyance motors (current)
- Material conveyance feeders (proximity)
- Facility ambient conditions (temperature)
- Process gasses (pressure)
- Accumulators (pressure)
- Raw material hoppers (humidity)
- Compressed air systems (various)
- Existing wired sensors (4-20mA, 0-24V)
- Fluid condition monitoring (4-20mA)
- Particle counting (4-20mA)
- Hydraulic power units (various)
- Rotational equipment (vibration)
- PLC integration (gateway)



Voice of the Machine Edge
East IT Gateway (18:9b:a5:10:1f:60) 🌐 English (US)

- Info
- Certificates
- Network
- Wi-Fi
- Remote Access
- Device Management
- OPC LDAP/AD Auth
- Users**
- API Tokens
- FTP Server
- External Storage
- License
- Status
- Backup/Restore

Voice of the Machine Edge Software

The industry’s most secure Edge-level solution. Seamlessly connect to nearly all industrial devices and systems, liberating, processing, and integrating the data from the factory floor into Cloud or on-premise, enterprise systems.

Overview
The Edge interface is designed to work seamlessly with a web browser-based user interface. Data is ingested from virtually any industrial asset. The software allows you to run various applications utilizing your data at the Edge, or send it securely to the Cloud for seamless enterprise integration.

Third-Party Cloud Integration
Send your processed and filtered data to the cloud interface or other third-party Cloud connectors to enable end-to-end solution creation.

User Defined Workflow
An extensive graphical user interface and flow-based configurations make solution building simplistic. Customize workflows to process and configure data flows internally or push data to external systems.

Data Flow
Integrate Operational Technologies (OT) with Information Technologies (IT) by sharing data throughout your organization. Data can be analyzed at the Edge, pushed to the Cloud, into data lakes, or integrated into most enterprise applications to meet numerous business needs.

Connectivity
Hundreds of pre-loaded drivers and protocols can connect to any modern (or legacy) data source. Automatic discovery of devices with no coding required.

Common Protocols:

- Ethernet/IP
- Modbus RTU/TCP
- OPCUA
- RS 232/485

Common Drivers:



- ABB
- Allen-Bradley
- Backnet
- Beckhoff
- Cutler-Hammer
- Danfoss
- Delta
- Emerson
- Ethernet
- GE
- Koyo
- LS
- Mitsubishi
- Modbus
- Omron
- OPCUA
- Opto22
- Panasonic
- Schneider
- Sick
- Siemens
- Yaskawa
- Yokogawa



Features:

- Available in a variety of pressure ranges from -14.5 psi to 8700 psi
- User-definable measurement units (psi/bar) for convenient and familiar data readings
- Port options: Male NPT or SAE thread and EMA or PD quick couplers for fast and easy connecting
- Corrosion resistant materials for challenging environments
- Sensor also provides ambient temperature values
- Configurable measurement and broadcast intervals*. Refer to Voice of the Machine Cloud for more information about capabilities and modalities.

Sensor Technical Data

							
Housing Material	Polycarbonate	Polycarbonate	Polycarbonate	Polycarbonate	Polycarbonate	Polycarbonate	Polycarbonate
Port	1/4" Male NPT	1/4" Male NPT	1/4" Male NPT	-4 SAE	-4 SAE	-4 SAE	-4 SAE
Wetted Parts Material	17-4 Stainless	17-4 Stainless	17-4 Stainless	17-4 Stainless and Nitrile	17-4 Stainless and Nitrile	17-4 Stainless and Nitrile	17-4 Stainless and Nitrile
Measurement Range (pressure)	-14.5 to 14.5 psi [-1 to 1 bar]	0-150 psi [10 bar]	0-232 psi [16 bar]	0-1500 psi [100 bar]	0-3625 psi [250 bar]	0-5800 psi [400 bar]	0-8700 psi [600 bar]
Max. Overload Pressure	29 psi	225 psi	350 psi	2250 psi	5440 psi	8700 psi	13,050 psi
Burst Pressure	3x	4x	4x	4x	4x	4x	4x
Accuracy (at 77°F/ 25°C)	1.5%	1.5%	1.5%	1.5%	1.5%	1.5%	1.5%
Resolution	.01 psi	.1 psi	.1 psi	1 psi	1 psi	1 psi	1 psi
Response Time (min)	1 sec	1 sec	1 sec	1 sec	1 sec	1 sec	1 sec
Ambient Temperature (battery limited)**	-4°F to 158°F [-20°C to 70°C]	-4°F to 158°F [-20°C to 70°C]	-4°F to 158°F [-20°C to 70°C]	-4°F to 158°F [-20°C to 70°C]	-4°F to 158°F [-20°C to 70°C]	-4°F to 158°F [-20°C to 70°C]	-4°F to 158°F [-20°C to 70°C]
Fluid Media Temperature Range	-40°F to 185°F [-40°C to 85°C]	-40°F to 185°F [-40°C to 85°C]	-40°F to 185°F [-40°C to 85°C]	-40°F to 185°F [-40°C to 85°C]	-40°F to 185°F [-40°C to 85°C]	-40°F to 185°F [-40°C to 85°C]	-40°F to 185°F [-40°C to 85°C]
Full Range Life Cycles	> 1 million	> 1 million	> 1 million	> 1 million	> 1 million	> 1 million	> 1 million
Certifications	FCC, IC, CE	FCC, IC, CE	FCC, IC, CE	FCC, IC, CE	FCC, IC, CE	FCC, IC, CE	FCC, IC, CE
Battery (Panasonic is recommended brand)	CR123A	CR123A	CR123A	CR123A	CR123A	CR123A	CR123A
IP Rating	IP65	IP65	IP65	IP65	IP65	IP65	IP65

Note: Consult QCD for other port options, pressure ratings, and port seal materials.

*Consult Subscription Agreement and Order Form or Parker QCD for any changes regarding data rates.

**Ambient temperature range can be broadened by installing Wired Power Adapter (SNWP2-2)



Pressure Sensors

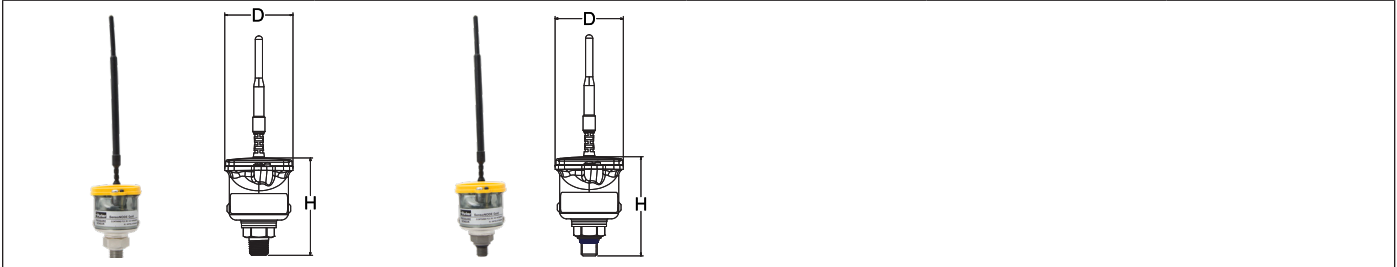

Part Number	Pressure Rating psi [bar]	Port	D	H
SNPT4-1-2-4MP	-14.5 to 14.5 [-1 to 1]	1/4" Male NPTF	ø1.88" [48mm]	2.66" [68mm]
SNPT4-10-2-4MP	0-150 [10]	1/4" Male NPTF	ø1.88" [48mm]	2.66" [68mm]
SNPT4-16-2-4MP	0-232 [16]	1/4" Male NPTF	ø1.88" [48mm]	2.66" [68mm]
SNPT4-100-2-4MO	0-1500 [100]	-4 SAE	ø1.88" [48mm]	2.72" [69mm]
SNPT4-250-2-4MO	0-3625 [250]	-4 SAE	ø1.88" [48mm]	2.72" [69mm]
SNPT4-400-2-4MO	0-5800 [400]	-4 SAE	ø1.88" [48mm]	2.72" [69mm]
SNPT4-600-2-4MO	0-8700 [600]	-4 SAE	ø1.88" [48mm]	2.72" [69mm]

Note: Products in catalog are currently only for sale in U.S., Canada, and Europe except where stated otherwise.

How to Order:

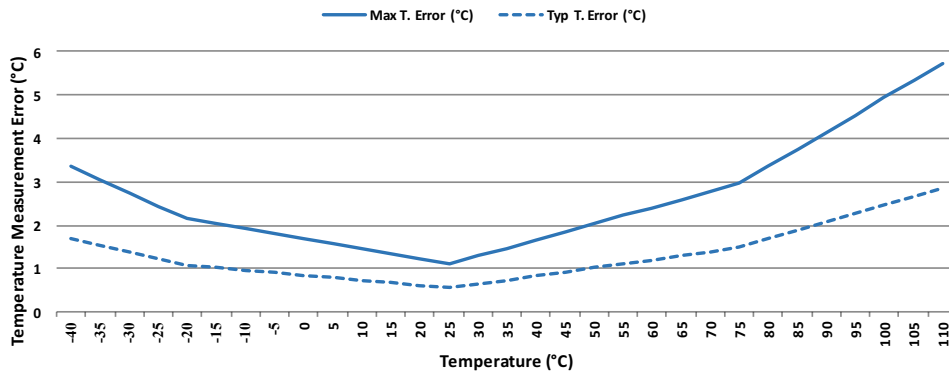
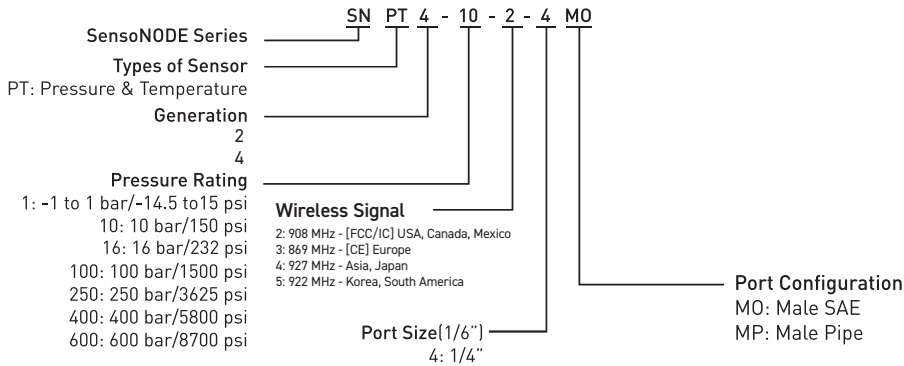

WARNING

The products listed can expose you to chemicals including Lead, which is known to the State of California to cause cancer, and to cause birth defects or other reproductive harm. For more information go to www.P65Warnings.ca.gov









Features:

- User-definable measurement units (F°/C°) for convenient and familiar data readings
- Port Options: Male NPTF and SAE
- Corrosion-resistant materials for challenging environments
- Configurable measurement and broadcast intervals*. Refer to Voice of the Machine Cloud for more information about capabilities and modalities.
- Available in unique foot design for quick attachment to pipe or hard tubing

Sensor Technical Data

					
Housing Material	Polycarbonate	Polycarbonate	Polycarbonate	Polycarbonate	Polycarbonate
Port	1/4" Male NPTF	-4 SAE	1/4" Male NPTF	-4 SAE	Foot
Wetted Parts Material	17-4 Stainless	17-4 Stainless and Nitrile	17-4 Stainless	17-4 Stainless and Nitrile	Stainless
Measurement Range (Fluid Temperature)	-40°F to 230°F [-40°C to 110°C]	-40°F to 230°F [-40°C to 110°C]	-40°F to 230°F [-40°C to 110°C]	-40°F to 230°F [-40°C to 110°C]	-40°F to 257°F [-40°C to 125°C]
Working Pressure	0-10k psi [0-700 bar]	0-9k psi [0-630 bar]	0-1500 psi [0-100 bar]	0-1500 psi [0-100 bar]	N/A
Max. Overload Pressure	3x	3x	2x	2x	N/A
Burst Pressure	4x	4x	3x	3x	N/A
Accuracy (at 77°F/ 25°C)	±3.0%	±3.0%	±3.0%	±3.0%	±5.0%
Resolution (from 14°F to 120°F)[-10°C to 44.8°C]	1°F [.56°C]	1°F [.56°C]	1°F [.56°C]	1°F [.56°C]	2°F [1.12°C]
Response Time (minimum)	1 sec	1 sec	1 sec	1 sec	1 sec
Ambient Temperature (battery limited)**	-4°F to 158°F [-20°C to 70°C]	-4°F to 158°F [-20°C to 70°C]	-4°F to 158°F [-20°C to 70°C]	-4°F to 158°F [-20°C to 70°C]	-4°F to 158°F [-20°C to 70°C]
Full Range Life Cycles	> 1 million	> 1 million	> 1 million	> 1 million	> 1 million
Certifications	FCC, IC, CE	FCC, IC, CE	FCC, IC, CE	FCC, IC, CE	FCC, IC, CE
Battery (Panasonic is recommended brand)	CR123A	CR123A	CR123A	CR123A	CR2450
IP Rating	IP65	IP65	IP65	IP65	IP65

Note: Consult QCD for other port options, pressure ratings, and port seal materials.

*Consult Subscription Agreement and Order Form or Parker QCD for any changes regarding data rates.

**Ambient temperature range can be broadened by installing Wired Power Adapter (SNWP2-2)



Temperature Sensors – Ported

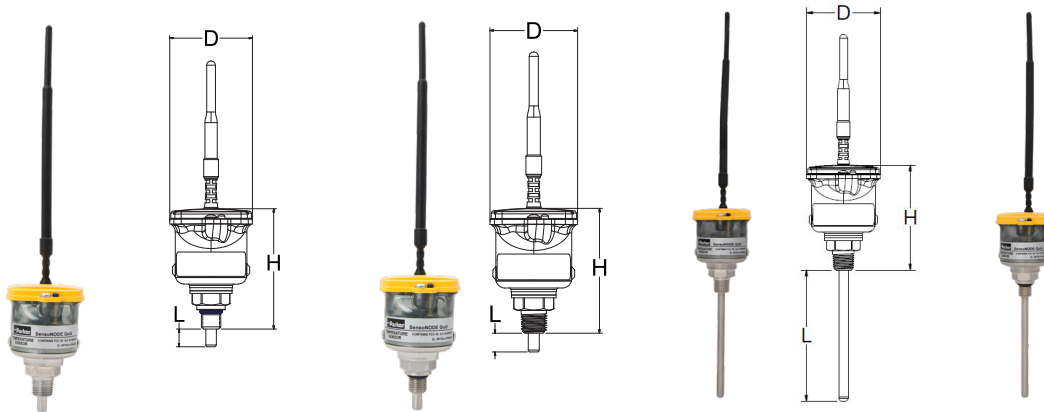

Part Number	Fluid Temperature Range	Port	D	H	L
SNT4-700-2-4MO	-40°F to 230°F [-40°C to 110°C]	-4 SAE	ø1.88" [48mm]	2.72" [69mm]	0.40" [10.16mm]
SNT4-700-2-4MP	-40°F to 230°F [-40°C to 110°C]	1/4" Male NPTF	ø1.88" [48mm]	2.66" [68mm]	0.40" [10.16mm]
SNT4-100-2-4MO-0335	-40°F to 230°F [-40°C to 110°C]	-4 SAE/Probe	ø1.88" [48mm]	2.72" [69mm]	3.35" [85mm]
SNT4-100-2-4MP-0335	-40°F to 230°F [-40°C to 110°C]	1/4" Male NPTF/Probe	ø1.88" [48mm]	2.66" [68mm]	3.35" [85mm]

Temperature Sensors – Foot

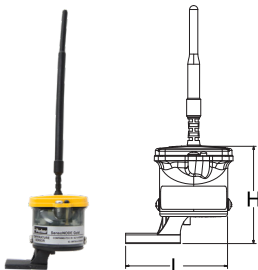

Part Number	Fluid Temperature Range	L	H	Optimal Clamping
SNT4-0-2-FT	-40°F to 257°F [-40°C to 125°C]	2.42" [61.5mm]	2.31" [58.7mm]	> Ø.25"+ [>Ø6.4mm]

Note: Products in catalog are currently only for sale in U.S., Canada, and Europe except where stated otherwise.

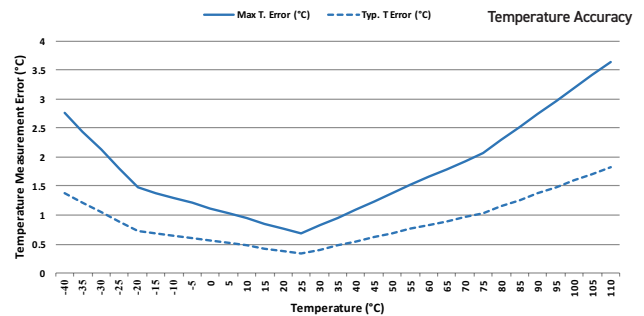

How to Order:

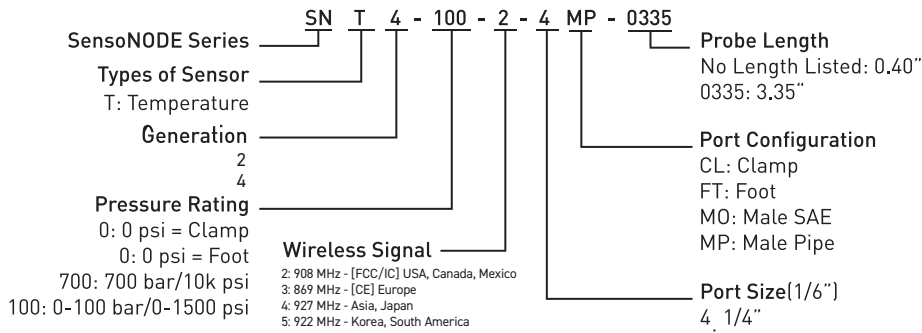

WARNING

The products listed can expose you to chemicals including Lead, which is known to the State of California to cause cancer, and to cause birth defects or other reproductive harm. For more information go to www.P65Warnings.ca.gov



Features:

- 0- 100% relative humidity
- Ideal for ambient condition and inert compressed gas monitoring applications
- NPTF port to make plumbing and connecting easier and faster
- Optimal mounting orientation is vertical with port facing down to prevent moisture collection
- Sensor also provides temperature values
- Configurable measurement and broadcast intervals*. Refer to the Voice of the Machine Cloud for more information about capabilities and modalities.

Sensor Technical Data	
Housing Material	Polycarbonate
Port	1/4" Male NPTF
Wetted Parts Material	Brass, Nitrile, Urethane, and GORE-TEX®
Measurement Range (Humidity)	0- 100% RH
Working Pressure	0- 150 psi [10 bar]
Max. Overload Pressure	150 psi Max [10 bar]
Burst Pressure	4x
Accuracy (77°F/25°C, 20% RH to 80% RH, at ambient pressure)	±5% RH Max
Resolution (at 77°F/25°C)	0.1% RH
Response Time (from 33% to 75% RH)	10 secs
Ambient Temperature (battery limited)**	-4°F to 158°F [-20°C to 70°C]
Temperature Accuracy (from 14°F to 185°F [-10°C to 85°C])	±1.0°F [±0.5°C]
Full Range Life Cycles	> 1 million
Certifications	FCC, IC, CE
Battery (Panasonic is recommended brand)	CR123A
IP Rating	IP65

*Consult Subscription Agreement and Order Form or Parker QCD for any changes regarding data rates.

**Ambient temperature range can be broadened by installing Wired Power Adapter (SNWP2-2)



Humidity Sensors				
Part Number	RH Range	Port	D	H
SNHT4-10-2-4MP	0-100%	1/4" Male NPTF	ø1.88" [48mm]	2.66" [68mm]

Note: Products in catalog are currently only for sale in U.S., Canada, and Europe except where stated otherwise.

RH Accuracy

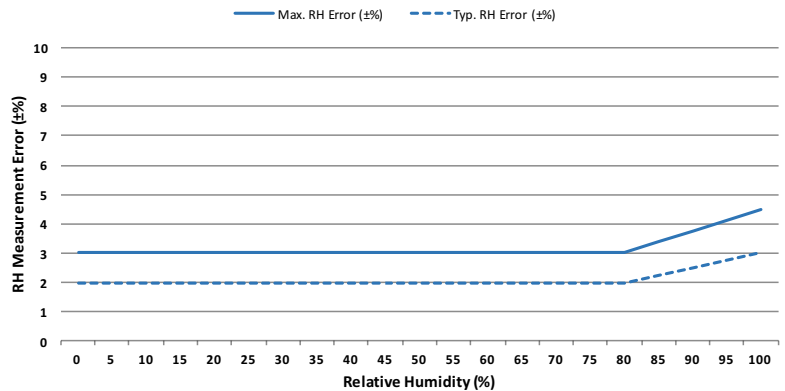

Temperature Accuracy

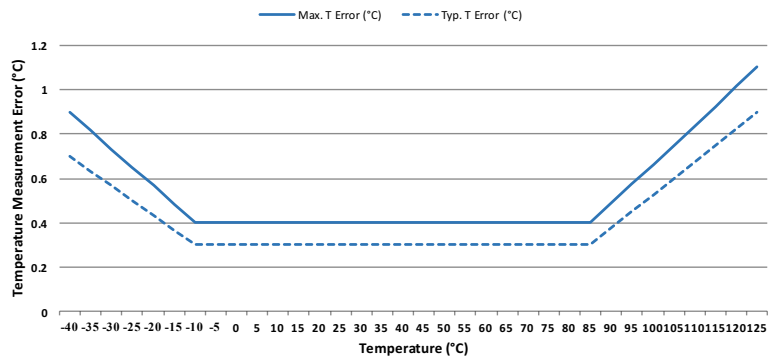

How to Order:

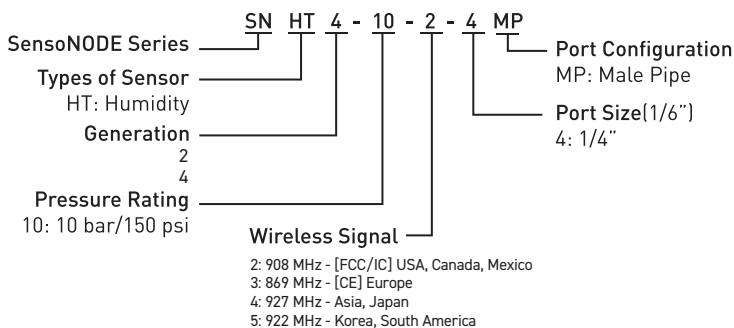

WARNING

The products listed can expose you to chemicals including Lead, which is known to the State of California to cause cancer, and to cause birth defects or other reproductive harm. For more information go to www.P65Warnings.ca.gov





Transmitter Technical Data

Base Material	Aluminum
Housing Material	Polycarbonate
Accuracy	0.5% (additive to source)
Resolution	0.1%
Temperature Range with Wired Power	-40 F- 185 F
Temperature Range with Battery	-4 F- 158 F
Full Range Life Cycles	> 1 million
Certifications	FCC, IC, CE
Battery (Panasonic is recommended brand)	CR123A
IP Rating	IP65

Features:

- Connects inline with any 4-20mA Sensor
- Integrates hard wired sensors into wireless Voice of the Machine Software
- Does not require reprogramming of existing control system
- Definable mapping feature in Cloud to present 4-20mA signal in user defined units
- Magnetic base for tool-free mounting
- Threaded stud port provides alternative mounting options where magnetic base is not suitable
- Requires connection cable SCK-400-xx-xx in conjunction with transmitter and 4-20mA Sensor

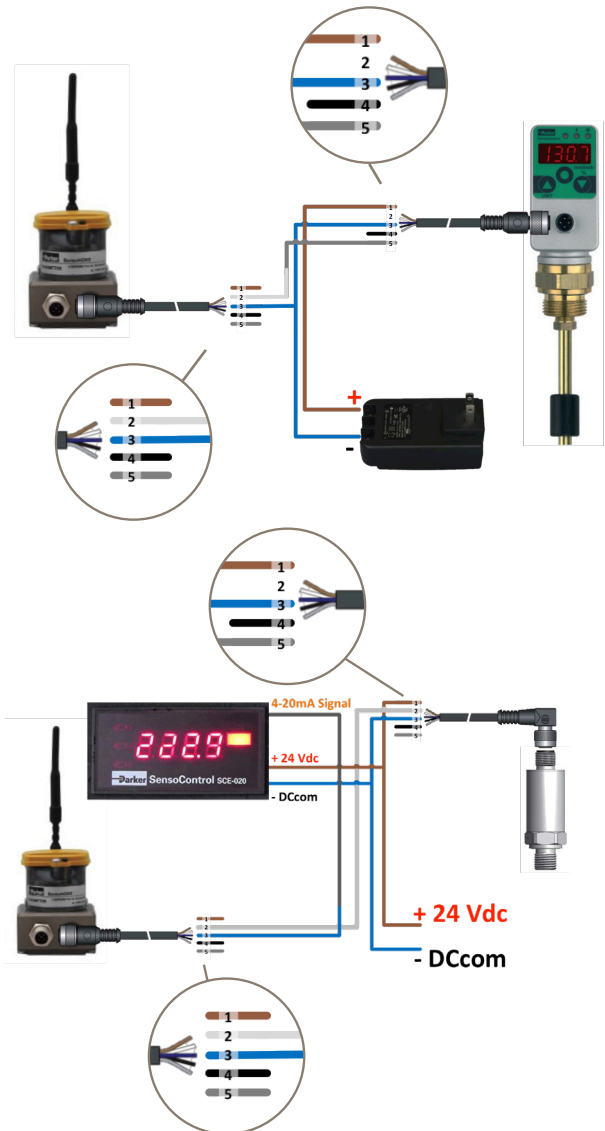

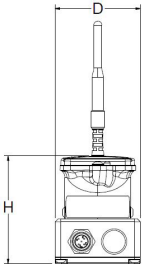
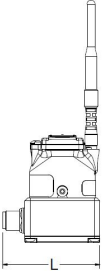

4-20mA Transmitter (Battery Powered)					
					
Part Number	Frequency	Base Mounting Thread	D	H	L
SN4204-2	900 MHz	1/4-28 UNF x0.45" [11mm]	2.11" [54mm]	2.67" [68mm]	2.41" [61mm]

Pin Assignment

PIN	Connection	Wire Color
1	No Connection	Brown
2	4-20mA Signal In	White
3	4-20mA Signal Out	Blue
4	No Connection	Black
5	No Connection	Gray

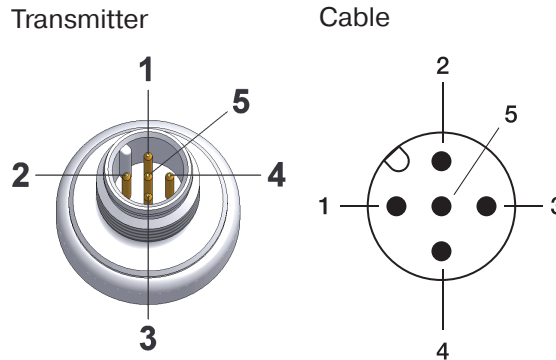

M12 Connection Cable

Part Number	Cable Length	Plug-in Connector
SCK-400-02-45	6.5 ft [2m]	M12 socket, straight
SCK-400-02-55	6.5 ft [2m]	M12 socket, 90
SCK-400-05-45	16 ft [5m]	M12 socket, straight
SCK-400-05-55	16 ft [5m]	M12 socket, 90
SCK-400-10-45	32.5 ft [10m]	M12 socket, straight
SCK-400-10-55	32.5 ft [10m]	M12 socket, 90

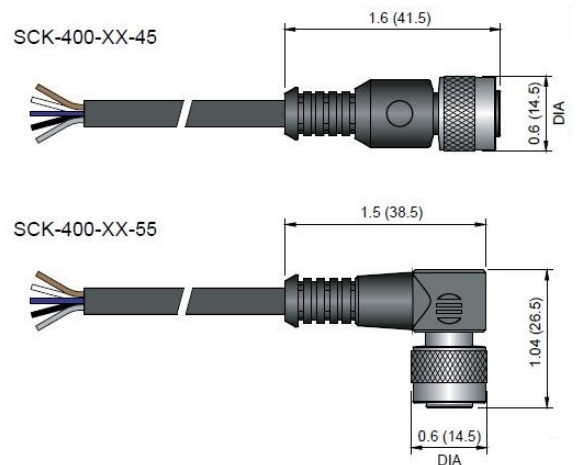

The products listed can expose you to chemicals including Lead, which is known to the State of California to cause cancer, and to cause birth defects or other reproductive harm. For more information go to www.P65Warnings.ca.gov





Features:

- Connects inline with common Voltage Sensors
- Dual channels offer connection with two Voltage Sensors
- Integrates hardwired sensors into wireless Voice of the Machine Edge software only
- Does not require reprogramming of existing control system
- Magnetic base for tool-free mounting
- Threaded stud port provides alternative mounting options where magnetic base is not suitable
- Requires connection cable SCK-400-xx-xx in conjunction with transmitter and Voltage Sensor

Technical Data	
Base Material	Aluminum
Housing Material	Polycarbonate
Analog Voltage Range	0-10VDC; 0-24VDC
Digital Voltage Range	0-2VDC = 0; +8VDC = 1
Accuracy	±2.0% for 0-10VDC (additive to source) ±3.0% for 0-24VDC (additive to source)
Resolution	0.03%
Max rated input voltage	32V (24VDC input, digital input) 16V (10VDC input)
Temperature Range with Wired Power	-40°F to 185°F
Temperature Range with Battery	-4°F to 158°F
Certifications	FCC & IC
Battery (Panasonic is recommended brand)	CR123A
IP Rating	IP65

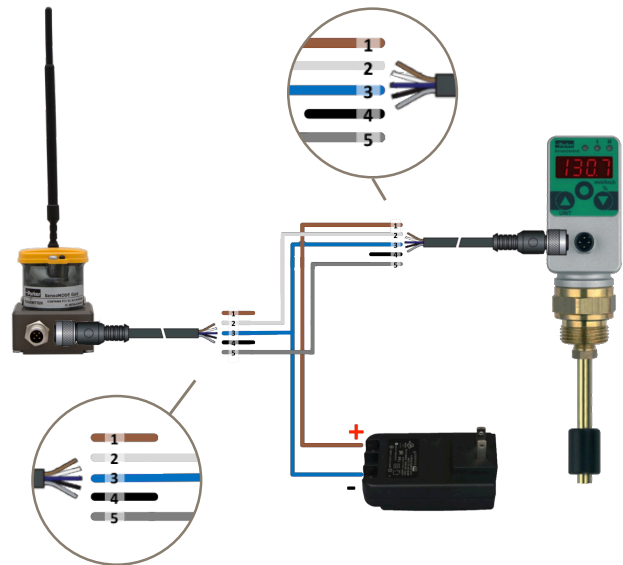



Transmitter

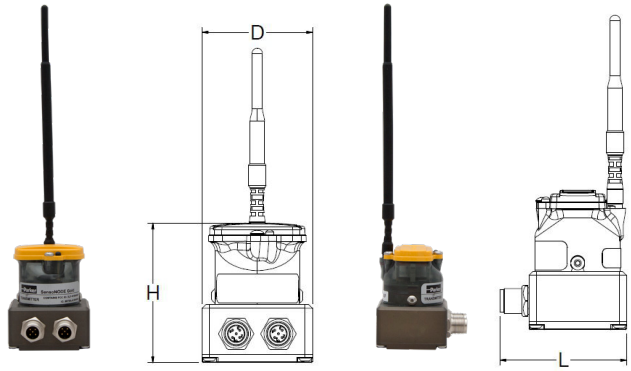

Part Number	Base Mounting Thread	D	H	L
SNDV4-2	1/4-28 UNF x 0.45" [11mm]	2.11" [54mm]	2.67" [68mm]	2.41" [61mm]

Pin Assignment

PIN	Connection	Wire Color
1	No Connection	Brown
2	Digital Input	White
3	0V/GND	Blue
4	10V Input	Black
5	24V Input	Gray

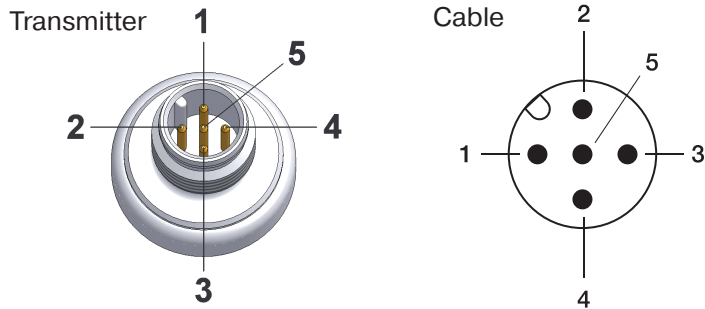

Technical Note: Only one voltage and one digital signal can be used concurrently per channel

M12 Connection Cable

Part Number	Cable Length	Plug-in Connector
SCK-400-02-45	6.5 ft [2m]	M12 socket, straight
SCK-400-02-55	6.5 ft [2m]	M12 socket, 90
SCK-400-05-45	16 ft [5m]	M12 socket, straight
SCK-400-05-55	16 ft [5m]	M12 socket, 90
SCK-400-10-45	32.5 ft [10m]	M12 socket, straight
SCK-400-10-55	32.5 ft [10m]	M12 socket, 90

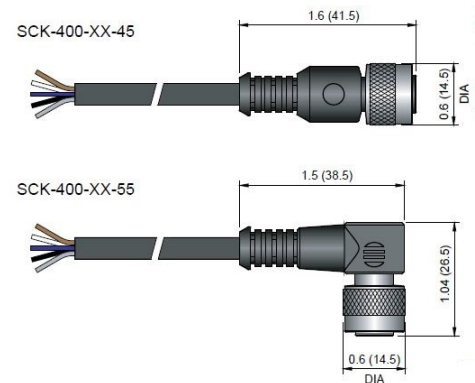

The products listed can expose you to chemicals including Lead, which is known to the State of California to cause cancer, and to cause birth defects or other reproductive harm. For more information go to www.P65Warnings.ca.gov





Features:

- Fast installation over a variety of power lead diameters
- Easy installation with 1/2” conduit threaded nipple mount
- Standard CT opening width is 1.25” for 50A through 600A service
- Other CT sizes available upon request
- Configurable measurement and broadcast intervals*. Refer to the Voice of the Machine Cloud for more information about capabilities and modalities.

Sensor Technical Data	
Base Material	Aluminum
Housing Material	Polycarbonate
Port	1/2-14 NPSM Thread
Measurement Range (Amperes)	50-600
Accuracy	5% (Full Span)
Resolution	0.1% (Full Span)
Ambient Temperature (battery limited)**	-4°F to 158°F [-20°C to 70°C]
Full Range Life Cycles	> 1 million
Certifications	FCC, IC, CE
Battery (Panasonic is recommended brand)	CR123A
IP Rating	IP65

*Consult Subscription Agreement and Order Form or Parker QCD for any changes regarding data rates.

**Ambient temperature range can be broadened by installing Wired Power Adapter (SNWP2-2)



Current

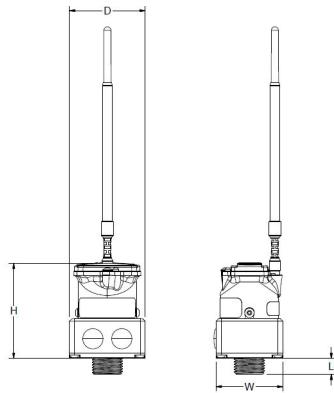

Part Number	Measurement Range	Port	D	H	W	L
SNC4-050-2	10-50 Amps	1/2-14 NPSM	2.11" [54mm]	2.67" [68mm]	1.86" [47mm]	.44" [11mm]
SNC4-100-2	20-100 Amps	1/2-14 NPSM	2.11" [54mm]	2.67" [68mm]	1.86" [47mm]	.44" [11mm]
SNC4-200-2	40-200 Amps	1/2-14 NPSM	2.11" [54mm]	2.67" [68mm]	1.86" [47mm]	.44" [11mm]
SNC4-300-2	60-300 Amps	1/2-14 NPSM	2.11" [54mm]	2.67" [68mm]	1.86" [47mm]	.44" [11mm]
SNC4-400-2	80-400 Amps	1/2-14 NPSM	2.11" [54mm]	2.67" [68mm]	1.86" [47mm]	.44" [11mm]
SNC4-600-2	120-600 Amps	1/2-14 NPSM	2.11" [54mm]	2.67" [68mm]	1.86" [47mm]	.44" [11mm]

Note: Products in catalog are currently only for sale in U.S., Canada, and Europe except where stated otherwise.

How to Order:

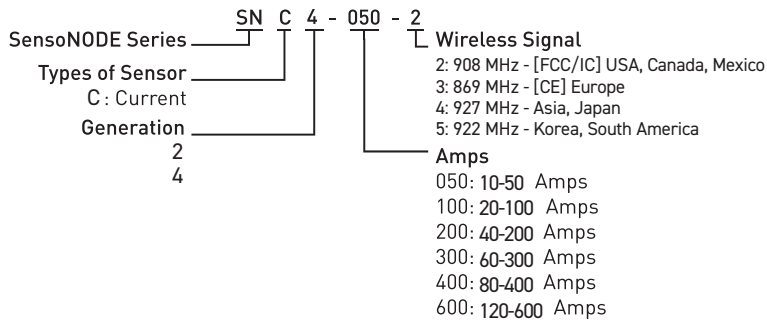

The products listed can expose you to chemicals including Lead, which is known to the State of California to cause cancer, and to cause birth defects or other reproductive harm. For more information go to www.P65Warnings.ca.gov





Features:

- Configurable acceleration amplitude
- +/- 2g, 4g, 8g or 16g
- 6.4 KHz sampling frequency
- 3 axis measurement
- RMS & Peak acceleration or velocity
- Temperature

Sensor Technical Data	
Housing Material	Polycarbonate
Base Material	Aluminum
Mounting Options	Magnet, 1/4-28 stud, Epoxy
Certifications	FCC, IC, CE
Battery (Panasonic is recommended brand)	CR123A
IP Rating	IP65

Acceleration Technical Data	
Acceleration Range	+/-2,+/-4, +/-8, +/-16 g absolute [configurable]
Frequency Range	1 Hz to 3200hz
Sampling Frequency	6.4 KHz
Measurement Output	Peak & RMS acceleration over frequency range; Temperature
Measurement Axes	X,Y, Z
Resolution (Peak)	+/- 2 g range = 1 mg, +/-4 g range = 2mg, +/-8 g range = 4mg, +/- 16 g range = 8mg
Temperature Sensor	-40 to +85 C
Samples Per Acquisition	800 samples
Filter Specs	DC offset removal

Velocity Technical Data	
Velocity Range	0 - 327 mm/sec
Frequency Range	7.5 Hz to 3200 Hz
Sampling Frequency	6.4 KHz
Measurement Output	Peak & RMS velocity over frequency range; Temperature
Measurement Axes	X, Y, Z
Resolution	0.01 mm/sec
Temperature Sensor	-40 to +85 C
Samples Per Acquisition	2200 samples
Filter Specs	7th order butterworth digital high pass filter, 60 dB down at 3 Hz, 3 db down at 7.5 Hz.



Transmitter

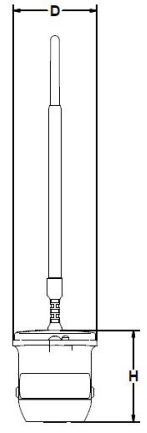

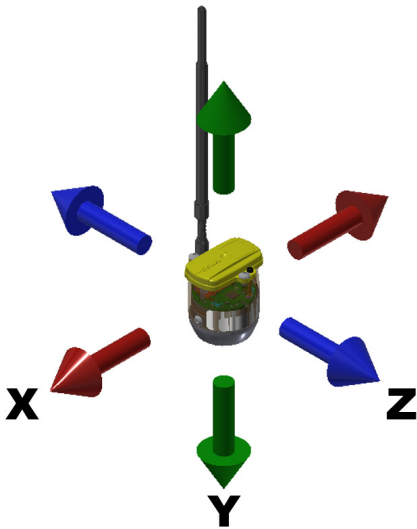

Part Number	Base Mounting Thread	D	H
SNVT4-1656-2	1/4-28 UNF	1.88" [48mm]	2.05" [52mm]

Measurement Axes

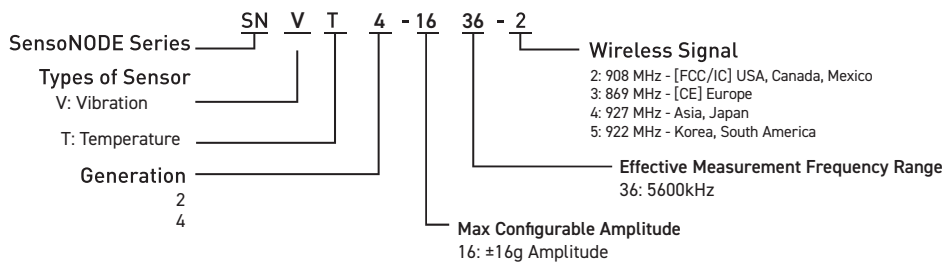

How to Order:



WARNING

The products listed can expose you to chemicals including Lead, which is known to the State of California to cause cancer, and to cause birth defects or other reproductive harm. For more information go to www.P65Warnings.ca.gov





Features:

- High-speed mechanical systems process pulse counter
- Connects to binary voltage output sensors:
 - Proximity Sensor
 - Light Curtain
 - Hall Effect
 - Reed Switch
- Accumulate and store pulse count data
- Internal memory
- Does not require reprogramming of existing control system
- Magnetic base for tool-free mounting
- Threaded stud port provides alternative mounting options where magnetic base is not suitable
- Requires connection cable SCK-400-xx-xx in conjunction with transmitter and sensor

Technical Data	
Base Material	Aluminum
Housing Material	Polycarbonate
Digital Voltage Range	0-2VDC Low; 8-32VDC High
Pulse	> 5 milliseconds on - > 5 milliseconds off
Total Count Resolution	32-bit counter = 4.2 billion cycles
Max rated input voltage	32V (24VDC nominal)
Temperature Range with Wired Power	-40°F to 185°F
Temperature Range with Battery	-4°F to 158°F
Certifications	FCC & IC
Battery (Panasonic is recommended brand)	CR123A
IP Rating	IP65



Pulse: High-to-low voltage pulse transition from external device

Channel: Used to determine which internal channel (A, B) the pulse count is represented in the data output

Transmitter

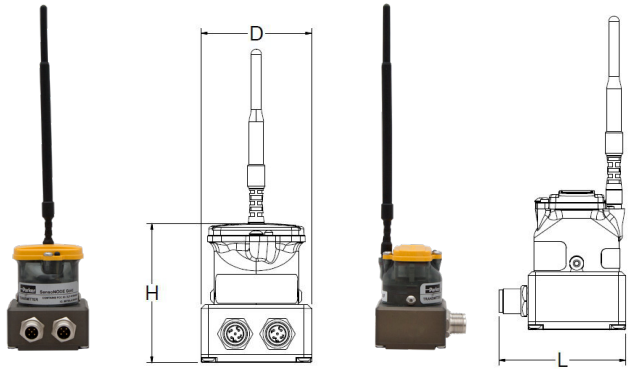

Part Number	Base Mounting Thread	D	H	L
SNCOUNT4-2	1/4-28 UNF x 0.45" [11mm]	2.11" [54mm]	2.67" [68mm]	2.41" [61mm]

Pin Assignment Pulse Side

PIN	Connection	Wire Color
1	No Connection	Brown
2	Pulse V+	White
3	0V/GND	Blue
4	No Connection	Black
5	No Connection	Gray

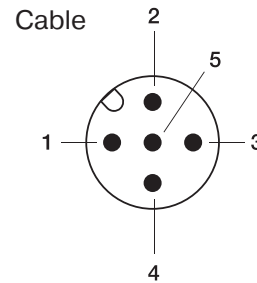
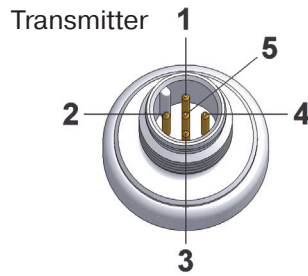

Pulse Input (0-2VDC Low; 8-32VDC High)

*A pulse is counted every high-to-low voltage transition

Pin Assignment Channel Side

PIN	Connection	Wire Color
1	No Connection	Brown
2	Channel V+	White
3	0V/GND	Blue
4	No Connection	Black
5	No Connection	Gray

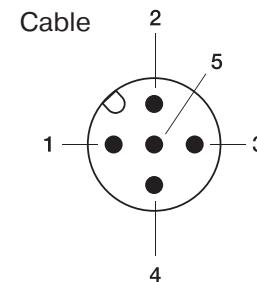
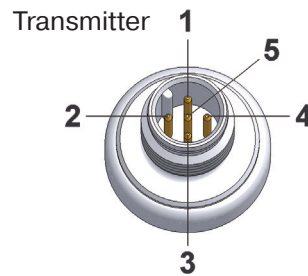

Channel (0-2VDC Channel A; 8-32VDC Channel B)

*Channel A and B are represented in the sensor pulse count data output

M12 Connection Cable

Part Number	Cable Length	Plug-in Connector
SCK-400-02-45	6.5 ft [2m]	M12 socket, straight
SCK-400-02-55	6.5 ft [2m]	M12 socket, 90
SCK-400-05-45	16 ft [5m]	M12 socket, straight
SCK-400-05-55	16 ft [5m]	M12 socket, 90
SCK-400-10-45	32.5 ft [10m]	M12 socket, straight
SCK-400-10-55	32.5 ft [10m]	M12 socket, 90

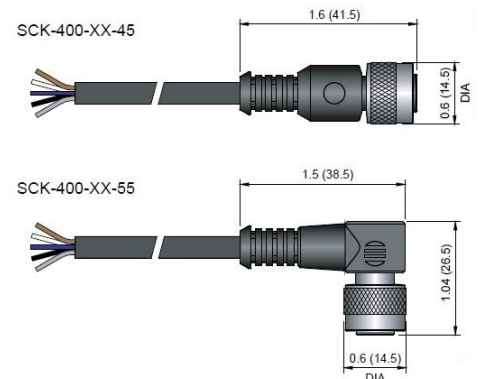

WARNING

The products listed can expose you to chemicals including Lead, which is known to the State of California to cause cancer, and to cause birth defects or other reproductive harm. For more information go to www.P65Warnings.ca.gov



Features:

- Enables remote wireless monitoring of fluid level
- Integrates seamlessly with Voice of the Machine software
- Eliminates necessity for communication cabling
- High visibility level display
- No surge pipe necessary
- Two switching outputs for independent process control

Kit Technical Data ¹					
SNCLSD4-KIT-	250	370	520	800	1000
Sensor length measurement range [inches (mm)]	9.8 (250)	14.6 (370)	20.5 (520)	31.5 (800)	39.4 (1000)
Active range [inches (mm)]	1.6 to 8.3 (40 to 210)	1.6 to 13 (40 to 330)	1.6 to 18.9 (40 to 480)	1.6 to 30 (40 to 760)	1.6 to 37.8 (40 to 960)
Increment size [inches (mm)]	0.2 (5)	0.2 (5)	0.2 (5)	0.4 (10)	0.4 (10)
Lowest reset point RSP [inches (mm)]	1.6 (40)	1.6 (40)	1.6 (40)	1.6 (40)	1.6 (40)
Largest switching value SP [inches (mm)]	8.3 (210)	13 (330)	18.9 (480)	30 (760)	37.8 (960)

Level Controller Technical Data ¹	
Input Parameters	
Measuring Component	Resistance reed chain with float
Connector thread	G3/4 BSPP; nickel-plated brass: ED soft seal NBR ²
Wetted Parts	Brass; nickel-plated brass, NBR ²
Fluid temperature range	-4 to 185°F
Media compatibility	Water; lubricating oil; hydraulic oil
Output Values	
Switching point accuracy	±1% FS at 77°F
Controller Display accuracy	±1% FS ±1 digit at 77°F
Response speed	≤700 ms
Controller resolution	0.3 inches
Float	
Material	NBR
Dimensions	Ø 0.7 inches, length 1.4 inches
Level Rod	
Material	Stainless Steel
Dimensions	Ø 0.3 inches
Operating pressure	14.5 psi

Transmitter Technical Data ³	
Base Material	Aluminum
Housing Material	Polycarbonate
Accuracy	0.5% (additive to source)
Resolution	0.1%
Ambient temperature (battery limited)	-4 to +158°F
Radio Certifications	FCC, IC, CE
Battery [Panasonic is recommended]	CR123A
IP Rating (Transmitter only)	IP65

¹Consult Parker Catalog 4083 for additional flow block details & data

²Different sealing material (FKM, EPDM, etc) upon request

³Consult Analog Transmitter portion of Parker Catalog 3864 for additional details

How to Order:

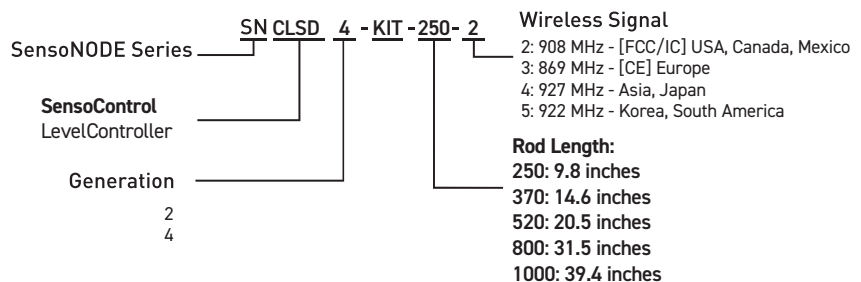



Technical Data

	<p>Analog Transmitter (SN4204-X)</p> <p>The transmitter wirelessly communicates the analog signal output from the controller to the gateway receiver for monitoring the fluid level of common tanks.</p>
	<p>LevelController (SCLSD-xxx-10-05)</p> <p>The LevelController combines the functions of a level switch, a level sensor and a level display. The LevelController is ideal for the monitoring of fluid level contents. The parameters are set using the keys or over a programming module.</p>
	<p>Mating Cable (SCK-WH-02-45-02)</p> <p>This connection cable (2 meter length) is uniquely designed to connect the analog signals from the controller to the wireless transmitter and switching outputs while also allowing the supply of sufficient voltage needed to power the controller.</p>
	<p>Power Lead (SCK-400-02-45)</p> <p>Connect this cable (2 meter length) via M12 plug to the mating cable to supply voltage to the system. A 15 to 30Vdc supply is required, and can be provided via flying leads from the factory DC power or the included 24Vdc power supply included within kit.</p>
	<p>Power Supply (SCSN-240)</p> <p>Provided as an easy solution to supply the appropriate voltage to the wireless kit system. Connect the appropriate Power Leads to corresponding terminals of power supply.</p> <p>Input Voltage: 90~264 VAC Output Voltage: 24Vdc</p>

Flying Lead Wire Diagram for Level Kit (SCK-400-02-45)

PIN	Connection	Wire Color
1	V Supply	Brown
2	S2 out	White
3	0 V/GND	Blue
4	S1 out	Black
5	No Connection	Gray

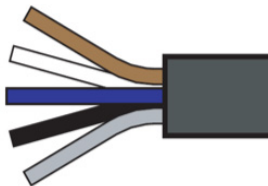

The products listed can expose you to chemicals including Lead, which is known to the State of California to cause cancer, and to cause birth defects or other reproductive harm. For more information go to www.P65Warnings.ca.gov





Features:

- Enables remote wireless monitoring of hydraulic flow
- Integrates seamlessly with Voice of the Machine software
- Eliminates necessity for communication cabling
- Turbine based measurement
- Measurement range 1 to 800 gpm
- Low flow resistance
- Capable of reverse flow measurement

Kit Technical Data ¹						
SNCFT4-KIT-	015	060	150	300	600	800
Flow Measuring Range: lpm (gpm)	0.25 to 4 (1 to 15)	0.8 to 16 (3 to 60)	1.3 to 40 (5 to 150)	2 to 80 (8 to 300)	4 to 160 (15 to 600)	5 to 210 (20 to 800)
Accuracy (±%) FS/IR @ 21cSt.	± 1 % FS	± 1 % IR	± 1 % IR	± 1 % IR	± 1 % IR	± 1 % IR
Operating Pressure Pn [psi (bar)]	5000 (350)	5000 (350)	5000 (350)	5000 (350)	4200 (290)	5800 (400)
Ports (A-B)	G1/2 BSPP	G3/4 BSPP	G3/4 BSPP	G1 BSPP	G1-1/4 BSPP	1-7/8 UNF
Pressure Drop ΔP [psi (bar)] @ (FS)	21 (1.5)	21 (1.5)	21 (1.5)	58 (4)	58 (4)	72 (5)
Weight [lbs (g)]	1.5 (700)	3.5 (1600)	3.5 (1600)	3.7 (1700)	6 (2700)	11 (5000)

Flow Turbine Technical Data ¹	
Accuracy	
Response time	50 ms
Thermal drift	±0.05 % FS/°C
Repeat accuracy	±0.5 % FS
Resistance to pressure	
Qmax (gpm)	Qn × 1.1
Overload pressure Pmax	Pn × 1.2
Material	
Flow Turbine Housing	Aluminum
Seal	FKM
Wetted Path	Aluminum, steel, FKM
Ambient Conditions	
Ambient temperature	+50 to +122°F
Storage temperature	-4 to +176°F
Tmax Fluid	-4 to +176°F
Filtration	25 μm (10 μm for SNCFT2-004)
Viscosity	15 to 100 cSt.
Protection Class	IP66

Transmitter Technical Data ²	
Base Material	Aluminum
Housing Material	Polycarbonate
Accuracy	0.5% (additive to source)
Resolution	0.1%
Ambient temperature (battery limited)	-4 to +158°F
Radio Certifications	FCC, IC, CE
Battery [Panasonic is recommended]	CR123A
IP Rating (Transmitter only)	IP65

¹Consult Parker Catalog 4083 for additional flow block details & data

²Consult Analog Transmitter portion of Parker Catalog 3864 for additional details

How to Order:

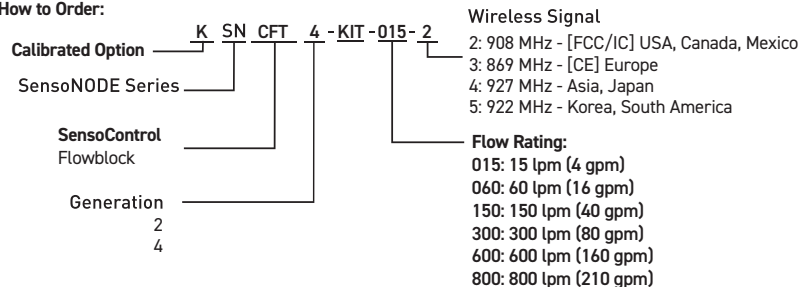



Technical Data	
	<p>Analog Transmitter (SN4204-X)</p> <p>The transmitter wirelessly communicates the analog signal output from the flow turbine to the gateway receiver for monitoring the condition of common hydraulic systems.</p>
	<p>Flow Turbine (SCFT-xxx-22-07)</p> <p>The turbine wheel is driven by the oil flow. The generated frequencies are processed through the digital electronics and influences from the disturbing flow effects are compensated for. Because of the low flow resistance Q_R, the hydraulic circuit operates with very low losses.</p> <p>Reverse operation is also possible because of the special vane (winged) design – so the turbine can be operated in both directions.</p> <p>The turbine casing also includes two plugged 7/16-20UN SAE ORB ports to add additional wireless pressure or temperature sensors directly in the oil flow. More details in Catalog 4083 pages 35-38. https://www.parker.com/content/dam/Parker-com/Literature/HPCE/New/CAT-4083-UK.pdf</p>
	<p>Mating Cable (SCK-WH-02-45-01)</p> <p>This connection cable (2 meter length) is uniquely designed to connect the analog signals from the flow turbine to the wireless transmitter while also allowing the supply of sufficient voltage needed to power the flow block.</p>
	<p>Power Lead (SCK-400-02-45)</p> <p>Connect this cable (2 meter length) via M12 plug to the mating cable to supply voltage to the system. An 18 to 30Vdc supply is required, and can be provided via flying leads from the factory DC power or the included 24Vdc power supply within kit.</p>
	<p>Power Supply (SCSN-240)</p> <p>Provided as an easy solution to supply the appropriate voltage to the wireless kit system. Connect the appropriate power leads to corresponding terminals of power supply.</p> <p>Input Voltage: 90~264 VAC Output Voltage: 24Vdc</p>

Flying Lead Wire Diagram for Flow Kit (SCK-400-02-45)

PIN	Connection	Wire Color
1	V Supply	Brown
2	No Connection	White
3	0 V/GND	Blue
4	No Connection	Black
5	No Connection	Gray

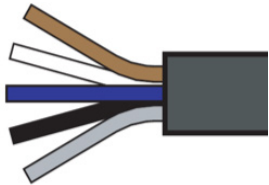

WARNING

The products listed can expose you to chemicals including Lead, which is known to the State of California to cause cancer, and to cause birth defects or other reproductive harm. For more information go to www.P65Warnings.ca.gov





Part Number

SN-G4-2-CA: IOT GATEWAY (ATT)

SN-G4-2-CV: IOT GATEWAY (VERIZON)

Feature	SN-G4-x-Cx
General	
Kernal	Linux Yocto
Processor	Intel® Core™ i5-9500
TDP	35 W
Number of Cores	6
Base Frequency	2.2 GHz
Maximum Turbo Frequency	3.6 GHz
PCH	C246
Memory	2x DDR4 SO-DIMMs, 16GB
IO Interfaces	
Display	2x DP++, DVI-D, VGA
Ethernet	3x Intel® GbE: 2x i210; iAMT supported
Wi-Fi	Wi-Fi 6e (2.4 2.495 GHz; 5.17-5.835 GHz; 5.925-7.125 GHz)
Bluetooth	BLE 5.3 (2.4 GHz)
Serial Ports	COM1/2: RS-232/422/485; COM3/4: RS-232
Digital I/O	8-Ch DI / 8-Ch DO
USB	3x USB 2.0; 2x USB 3.1 G2; 1x USB 3.1 G1
Audio	Line out; Mic in
Mini PCIe	USB 2.0+Pcle
M.2	1x socket 2, key B+M or B 1x 2280 / 3042 (USB 3.1 + SATA 6 Gb/s + 2x PCIe)
USIM	2x nanoSIM slot
Security	
TPM	TPM2.0
Storage	
Disk	256GB Internal 2.5" SATA, 1x slot
Technology	Power Loss Protection
Physical	
Cooling	Fanless
Dimensions	3.39" (H) x 8.27" (W) x 9.45" (D)
Weight	Net: 10.36 lbs ; Gross: 11.68 lbs
Mounting	Desktop; wall mount



WARNING

The products listed can expose you to chemicals including Lead, which is known to the State of California to cause cancer, and to cause birth defects or other reproductive harm. For more information go to www.P65Warnings.ca.gov

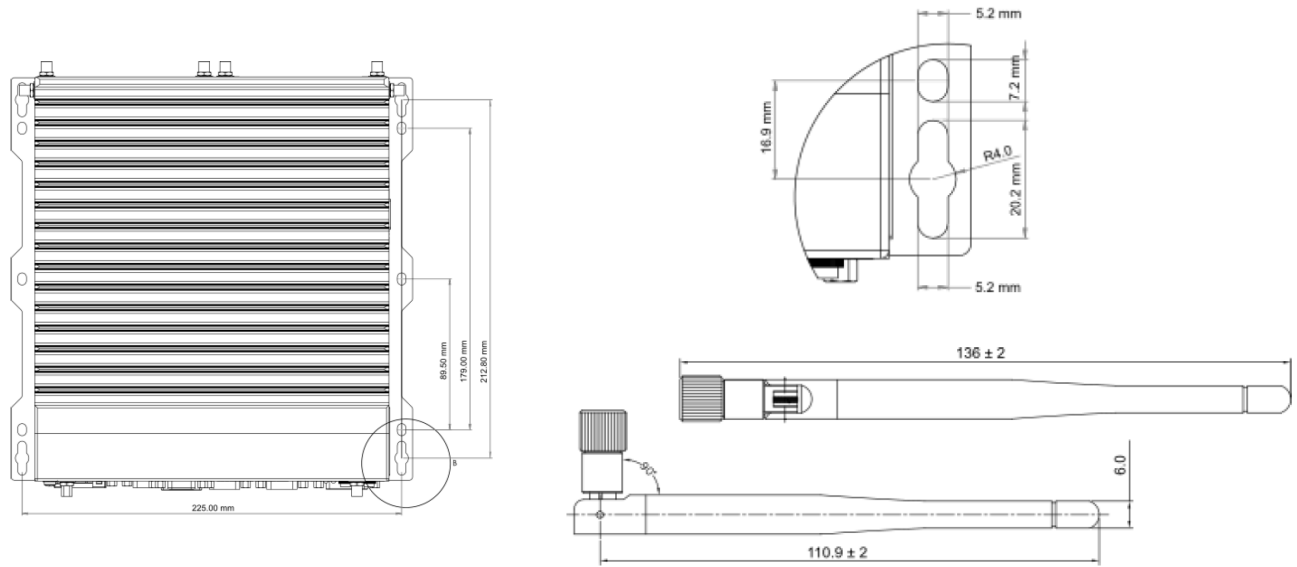

Specifications	Description
Power Supply	
DC Input	12-24V (±10% tolerance)
AC Input	Optional: 180W; 60W (PoE); AC-DC adapter
Environmental	
Operating Temperature	32°F to 140°F (with 2.0 ft/s airflow) Derate Max Temp 1.8°F / 1,000 ft above sea level
Storage Temperature	-40°F to 185°F (excluding storage devices)
Altitude	Sea level to 3 miles
Humidity	95% at 104°F
Vibration	MIL-STD-810G METHOD 514.6 category 4
Shock	IEC-60068-2-27, half sine pulse 20G, MIL-STD-810G METHOD 516.6; sawtooth pulse
IP Rating	IP30
EMC	FCC, CE, ICES
Safety	IEC, EN, UL, CSA 63268-1
Regions	
United States, Canada, Mexico	2 (915 MHz)
European Union	3 (868 MHz)
Japan	4 (926 MHz)
Australia / New Zealand / Brazil / Chile	5 (922 MHz)
South Korea	6 (922 MHz)
Cellular	
AT&T	CA (all certifications completed)
Verizon	CV (all certifications completed)
Custom	Customer provided SIM and APN
SIM	Nano SIM (12.3mm x 8.8mm; 4FF)
Modem	Telit MV31-W



WARNING

The products listed can expose you to chemicals including Lead, which is known to the State of California to cause cancer, and to cause birth defects or other reproductive harm. For more information go to www.P65Warnings.ca.gov

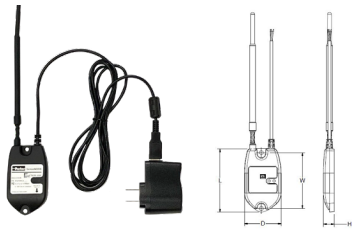

Wireless Receiver				
Part Number	W	D	H	L
SN-WR4-2				

Repeater				
		<ul style="list-style-type: none"> • Primary use as network repeater [range extender] for all sensors joined to gateway receiver • Support for up to 250 sensors at one hop each • Robust overmolded design for harsh environments 		
Part Number	W	D	H	L
SNREN-2	2.75" [70mm]	1.81" [46mm]	.53" [13mm]	3.12" [79mm]

**Features:**

- Supplies continuous power to sensors
- Used with IEC/UL 508 Class 2 power supply
- Easy upgrade eliminates the need for battery replacement
- Extends temperature range over batteries
- FCC, IC, and CE certified when used with SensoNODE products

Technical Data

Part Number	SNWP2-2
Wire Length	9.8 ft [3m]
Temperature Range	-40 F- 185 F
Input Power	5-36 Volts DC
Output Power	3 Volts DC
Connection	Flying lead 24 AWG Wires
Form	CR123A Battery

WARNING

The products listed can expose you to chemicals including Lead, which is known to the State of California to cause cancer, and to cause birth defects or other reproductive harm. For more information go to www.P65Warnings.ca.gov

SensoNODE™ Gold and Voice of the Machine™ Cloud Site Survey Kit



The SensoNODE Gold and Voice of the Machine Cloud Site Survey Kit is the first step in the installation of Parker's condition monitoring solution.

The Site Survey Kit determines the precise location of the Parker Gateway and SensoNODE Sensors.

The Kit establishes the best site plan and identifies obstacles.

Part Number

SNSK4

Site Survey Kit includes:

- SensoNODE Gold Site Survey Node
- Parker Receiver Node (PRN)
- Parker Repeater



SCC-255

SensoNODE Accessory Case

Part Number	L	W	D	Case
SCC-255*	14"	11.5"	5"	Blow Molded Case

*Sensor products not included.

Battery (CR123A)



Part Number	Technology	Voltage
QX-008-121	Lithium Ion	3.00V

Test Port Couplings

Quick Coupling Products
 Quick Couplings, Swivels, Valves,
 Diagnostic Sensors and Equipment
 Catalog 3800 USA | November 2022

Parker
 ENGINEERING YOUR SUCCESS.

[Catalog 3800](#)
[Quick Coupling Products](#)
[Page B-99](#) ▶



For information and availability of Test Port Couplings, review Parker's Catalog 3800, page B-99.



WARNING The products listed can expose you to chemicals including Lead, which is known to the State of California to cause cancer, and to cause birth defects or other reproductive harm. For more information go to www.P65Warnings.ca.gov

SensoNODE™ Silver Sensors and Voice of the Machine™ Cloud Interface

Our SensoNODE Silver wireless sensors utilize cellular technology to send data directly to the Voice of the Machine Cloud Interface. This means no gateway is required. This makes SensoNODE Silver ideal for applications where gateways are impossible or inconvenient.

SensoNODE Silver Sensors are best for applications when infrequent measurements are needed to monitor equipment or machines. The sensors are IP65 rated. They require (3) Energizer AA batteries.

Should you not see a pressure range which satisfies your needs, do not see a port configuration which you require, or foresee a unique use-case which requires insight and experience to achieve success, please contact us. We are happy to work with your team to create custom configurations.

SensoNODE™ Silver Sensors

Communication Technology: Cellular

Software Platform: Voice of the Machine™ Cloud

Interface: Optimized for Windows, Linux, and MacOS based hardware. Android and iOS mobile devices.

Data Storage: Cloud

Applications: Infrequent continuous measurements. Locations where gateways are impossible or inconvenient. Single sensor implementations.

Sensor Types: Pressure

Requirements: Voice of the Machine™ Cloud and cellular service

Voice of the Machine™ Cloud Interface

Cloud-based software interface provides flexible organizational structure. Easy enough to visualize a single sensor. Robust enough to present unlimited customers, locations, assets, sensors, and signals in an easily digestible format.

Interface: Optimized for Windows, Linux, and MacOS based hardware via an internet browser. Android and iOS mobile devices via mobile internet browser.

Sensors: SensoNODE™ Gold and Silver

Data Storage: Cloud

Applications: Continuous condition monitoring at predetermined intervals. Designed for in-plant, on-premise use, or remote locations. Low implementation effort required. View SensoNODE™ Gold and Silver signals on single dashboard.

Requirements: Parker Gateway, internet connectivity

- Customizable dashboards
- Email / SMS alerts
- Gateway statistics
- Historical graphing
- Kiosk display mode
- Live measurements
- OEM cloud instances
- Sensor battery levels
- Templating capabilities
- Wireless signal strengths



Features:

- Available in a variety of pressure ranges from -14.5 psi to 8700 psi.
- There are actually 23 user-selectable units of measure (for pressure alone) in the VoM Cloud
- User-definable measurement units (psi/bar) for convenient and familiar data readings.
- Port options: Male NPT or SAE thread and EMA or PD quick couplers for fast and easy connecting.
- Corrosion resistant materials for challenging environments.
- Sensor also provides ambient temperature values.
- Sensors are set with a report rate of once every 20 minutes.

Sensor Technical Data

Housing Material	Polycarbonate	Polycarbonate	Polycarbonate	Polycarbonate	Polycarbonate	Polycarbonate	Polycarbonate
Port	1/4" Male NPT	1/4" Male NPT	1/4" Male NPT	-4 SAE	-4 SAE	-4 SAE	-4 SAE
Wetted Parts Material	17-4 Stainless	17-4 Stainless	17-4 Stainless	17-4 Stainless and Nitrile	17-4 Stainless and Nitrile	17-4 Stainless and Nitrile	17-4 Stainless and Nitrile
Measurement Range (pressure)	-14.5 to 14.5 psi [-1 to 1 bar]	0-150 psi [10 bar]	0-232 psi [16 bar]	0-1500 psi [100 bar]	0-3625 psi [250 bar]	0-5800 psi [400 bar]	0-8700 psi [600 bar]
Max. Overload Pressure	29 psi	225 psi	350 psi	2250 psi	5440 psi	8700 psi	13,050 psi
Burst Pressure	3x	4x	4x	4x	4x	4x	4x
Accuracy (at 77°F/ 25°C)	1.5%	1.5%	1.5%	1.5%	1.5%	1.5%	1.5%
Resolution	.01 psi	.1 psi	.1 psi	1 psi	1 psi	1 psi	1 psi
Measurement and Broadcast Interval	User Selectable	User Selectable	User Selectable	User Selectable	User Selectable	User Selectable	User Selectable
Report Rate (min)	20 min	20 min	20 min	20 min	20 min	20 min	20 min
Ambient Temperature* (battery limited)	-4°F to 158°F [-20°C to 70°C]	-4°F to 158°F [-20°C to 70°C]	-4°F to 158°F [-20°C to 70°C]	-4°F to 158°F [-20°C to 70°C]	-4°F to 158°F [-20°C to 70°C]	-4°F to 158°F [-20°C to 70°C]	-4°F to 158°F [-20°C to 70°C]
Fluid Media Temperature Range	-40°F to 185°F [-40°C to 85°C]	-40°F to 185°F [-40°C to 85°C]	-40°F to 185°F [-40°C to 85°C]	-40°F to 185°F [-40°C to 85°C]	-40°F to 185°F [-40°C to 85°C]	-40°F to 185°F [-40°C to 85°C]	-40°F to 185°F [-40°C to 85°C]
Full Range Life Cycles	> 1 million	> 1 million	> 1 million	> 1 million	> 1 million	> 1 million	> 1 million
Certifications	FCC, IC	FCC, IC	FCC, IC	FCC, IC	FCC, IC	FCC, IC	FCC, IC
Battery (Energizer is recommended brand)	AA	AA	AA	AA	AA	AA	AA
IP Rating	IP65	IP65	IP65	IP65	IP65	IP65	IP65

Note: Consult QCD for other port options, pressure ratings, and port seal materials.

*Ambient temperature range can be broadened by installing Wired Power Adapter (SNWP2-B)

Pressure Sensors

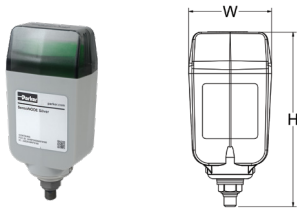

Part Number	Pressure Rating psi [bar]	Port	Width	Height
SNPT4-1-CA-4MP	-14.5 to 14.5 [-1 to 1]	1/4" Male NPT	3.00" [76mm]	6.33" [161mm]
SNPT4-10-CA-4MP	0-150 [10]	1/4" Male NPT	3.00" [76mm]	6.33" [161mm]
SNPT4-16-CA-4MP	0-232 [16]	1/4" Male NPT	3.00" [76mm]	6.33" [161mm]
SNPT4-100-CA-4MO	0-1500 [100]	-4 SAE	3.00" [76mm]	6.33" [161mm]
SNPT4-250-CA-4MO	0-3625 [250]	-4 SAE	3.00" [76mm]	6.33" [161mm]
SNPT4-400-CA-4MO	0-5800 [400]	-4 SAE	3.00" [76mm]	6.33" [161mm]
SNPT4-600-CA-4MO	0-8700 [600]	-4 SAE	3.00" [76mm]	6.33" [161mm]

Note: Products in catalog are currently only for sale in U.S and Canada.

How to Order:

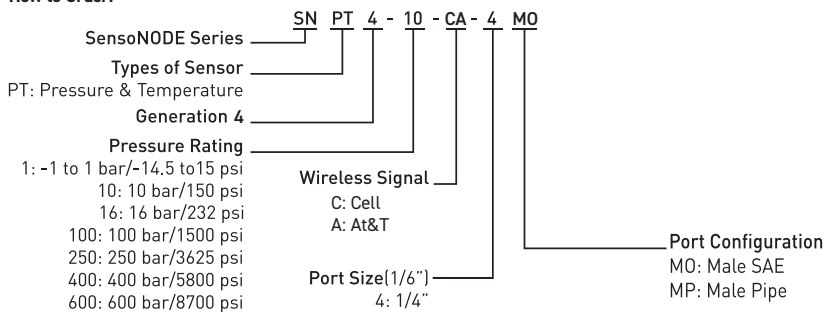

WARNING

The products listed can expose you to chemicals including Lead, which is known to the State of California to cause cancer, and to cause birth defects or other reproductive harm. For more information go to www.P65Warnings.ca.gov

Offer of Sale

1. Definitions. As used herein, the following terms have the meanings indicated.

Buyer: means any customer receiving a Quote for Products.

Goods: means any tangible part, system or component to be supplied by Seller.

Products: means the Goods, Services and/or Software as described in a Quote.

Quote: means the offer or proposal made by Seller to Buyer for the supply of Products.

Seller: means Parker-Hannifin Corporation, including all divisions and businesses thereof.

Services: means any services to be provided by Seller.

Software: means any software related to the Goods, whether embedded or separately downloaded.

Terms: means the terms and conditions of this Offer of Sale.

2. Terms. All sales of Products by Seller are expressly conditioned upon, and will be governed by the acceptance of, these Terms. These Terms are incorporated into any Quote provided by Seller to Buyer. Buyer's order for any Products whether communicated to Seller verbally, in writing, by electronic data interface or other electronic commerce, shall constitute acceptance of these Terms. Seller objects to any contrary or additional terms or conditions of Buyer. Reference in Seller's order acknowledgement to Buyer's purchase order or purchase order number shall in no way constitute an acceptance of any of Buyer's terms or conditions of purchase. No modification to these Terms will be binding on Seller unless agreed to in writing and signed by an authorized representative of Seller.

3. Price; Payment. The Products set forth in the Quote are offered for sale at the prices indicated in the Quote. Unless otherwise specifically stated in the Quote, prices are valid for thirty (30) days and do not include any sales, use, or other taxes or duties. Seller reserves the right to modify prices at any time to adjust for any raw material price fluctuations. Unless otherwise specified by Seller, all prices are F.C.A. Seller's facility (INCOTERMS 2020). All sales are contingent upon credit approval and full payment for all purchases is due thirty (30) days from the date of invoice (or such date as may be specified in the Quote). Unpaid invoices beyond the specified payment date incur interest at the rate of 1.5% per month or the maximum allowable rate under applicable law.

4. Shipment; Delivery; Title and Risk of Loss. All delivery dates are approximate, and Seller is not responsible for damages resulting from any delay. Regardless of the manner of shipment, delivery occurs and title and risk of loss or damage pass to Buyer, upon placement of the Products with the carrier at Seller's facility. Unless otherwise agreed prior to shipment and for domestic delivery locations only, Seller will select and arrange, at Buyer's sole expense, the carrier and means of delivery. When Seller selects and arranges the carrier and means of delivery, freight and insurance costs for shipment to the designated delivery location will be prepaid by Seller and added as a separate line item to the invoice. Buyer shall be responsible for any additional shipping charges incurred by Seller due to Buyer's acts or omissions. Buyer shall not return or repackage any Products without the prior written authorization from Seller, and any return shall be at the sole cost and expense of Buyer.

5. Warranty. The warranty for the Products is as follows: (i) Goods are warranted against defects in material or workmanship for a period of twelve (12) months from the date of delivery or 2,000 hours of use, whichever occurs first; (ii) Services shall be performed in accordance with generally accepted practices and using the degree of care and skill that is ordinarily exercised and customary in the field to which the Services pertain and are warranted for a period of six (6) months from the date of completion of the Services; and (iii) Software is only warranted to perform in accordance with applicable specifications provided by Seller to Buyer from the date of the initial download. All prices are based upon the exclusive limited warranty stated above, and upon the following disclaimer: **EXEMPTION CLAUSE: DISCLAIMER OF WARRANTY, CONDITIONS, REPRESENTATIONS: THIS WARRANTY IS THE SOLE AND ENTIRE WARRANTY, CONDITION, AND REPRESENTATION, PERTAINING TO PRODUCTS. SELLER DISCLAIMS ALL OTHER WARRANTIES, CONDITIONS, AND REPRESENTATIONS, WHETHER STATUTORY, EXPRESS OR IMPLIED, INCLUDING BUT NOT LIMITED TO THOSE RELATING TO DESIGN, NON-INFRINGEMENT, MERCHANTABILITY, AND FITNESS FOR A PARTICULAR PURPOSE. SELLER DOES NOT WARRANT THAT THE SOFTWARE IS ERROR-FREE OR FAULT-TOLERANT, OR THAT BUYER'S USE THEREOF WILL BE SECURE OR UNINTERRUPTED. UNLESS OTHERWISE AUTHORIZED IN WRITING BY SELLER, THE SOFTWARE SHALL NOT BE USED IN CONNECTION WITH HAZARDOUS OR HIGH RISK ACTIVITIES OR ENVIRONMENTS. EXCEPT AS EXPRESSLY STATED HEREIN, ALL PRODUCTS ARE PROVIDED "AS IS".**

6. Claims; Commencement of Actions. Buyer shall promptly inspect all Products upon receipt. No claims for shortages will be allowed unless reported to Seller within ten (10) days of delivery. Buyer shall notify Seller of any alleged breach of warranty within thirty (30) days after the date the non-conformance is or should have been discovered by Buyer. Any claim or action against Seller based upon breach of contract or any other theory, including tort, negligence, or otherwise must be commenced within twelve (12) months from the date of the alleged breach or other alleged event, without regard to the date of discovery.

7. LIMITATION OF LIABILITY. IN THE EVENT OF A BREACH OF WARRANTY, SELLER WILL, AT ITS OPTION, REPAIR OR REPLACE THE NON-CONFORMING PRODUCT, RE-PERFORM THE SERVICES, OR REFUND THE PURCHASE PRICE PAID WITHIN A REASONABLE PERIOD OF TIME. IN NO EVENT IS SELLER LIABLE FOR ANY SPECIAL, INDIRECT, INCIDENTAL OR CONSEQUENTIAL DAMAGES INCLUDING ANY LOSS OF REVENUE OR PROFITS, WHETHER BASED IN CONTRACT, TORT OR OTHER LEGAL THEORY. IN NO EVENT SHALL SELLER'S LIABILITY UNDER ANY CLAIM MADE BY BUYER EXCEED THE PURCHASE PRICE PAID FOR THE PRODUCTS.

8. Confidential Information. Buyer acknowledges and agrees that any technical, commercial, or other confidential information of Seller, including, without limitation, pricing, technical drawings or prints and/or part lists, which has been or will be disclosed, delivered or made available, whether directly or indirectly, to Buyer ("Confidential Information"), has been and will be received in confidence and will remain the property of Seller. Buyer further agrees that it will not use Seller's Confidential Information for any purpose other than for the benefit of Seller.

9. Loss to Buyer's Property. Any tools, patterns, materials, equipment or information furnished by Buyer or which are or become Buyer's property ("Buyer's Property"), will be considered obsolete and may be destroyed by Seller after two (2) consecutive years have elapsed without Buyer ordering the Products manufactured using Buyer's Property. Furthermore, Seller shall not be responsible for any loss or damage to Buyer's Property while it is in Seller's possession or control.

10. Special Tooling. "Special Tooling" includes but is not limited to tools, jigs, fixtures and associated manufacturing equipment acquired or necessary to manufacture Goods. Seller may impose a tooling charge for any Special Tooling. Such Special Tooling shall be and remain Seller's property notwithstanding payment of any charges by Buyer. In no event will Buyer acquire any interest in the Special Tooling, even if such Special Tooling has been specially converted or adapted for manufacture of Goods for Buyer and notwithstanding any charges paid by Buyer. Unless otherwise agreed, Seller has the right to alter, discard or otherwise dispose of any Special Tooling or other property owned by Seller in its sole discretion at any time.

11. Security Interest. To secure payment of all sums due from Buyer, Seller retains a security interest in all Products delivered to Buyer and, Buyer's acceptance of these Terms is deemed to be a Security Agreement under the Uniform Commercial Code. Buyer authorizes Seller as its attorney to execute and file on Buyer's behalf all documents Seller deems necessary to perfect Seller's security interest.

12. User Responsibility. Buyer, through its own analysis and testing, is solely responsible for making the final selection of the Products and assuring that all performance, endurance, maintenance, safety and warning requirements of the application of the Products are met. Buyer must analyze all aspects of the application and follow applicable industry standards, specifications, and any technical information provided with the Quote or the Products, such as Seller's instructions, guides and specifications. If Seller provides options of or for Products based upon data or specifications provided by Buyer, Buyer is responsible for determining that such

data and specifications are suitable and sufficient for all applications and reasonably foreseeable uses of the Products. In the event Buyer is not the end-user of the Products, Buyer will ensure such end-user complies with this paragraph.

13. Use of Products; Indemnity by Buyer. Buyer shall comply with all instructions, guides and specifications provided by Seller with the Quote or the Products. **Unauthorized Uses.** If Buyer uses or resells the Products in any way prohibited by Seller's instructions, guides or specifications, or Buyer otherwise fails to comply with Seller's instructions, guides and specifications, Buyer acknowledges that any such use, resale, or non-compliance is at Buyer's sole risk. Further, Buyer shall indemnify, defend, and hold Seller harmless from any losses, claims, liabilities, damages, lawsuits, judgments and costs (including attorney fees and defense costs), whether for personal injury, property damage, intellectual property infringement or any other claim, arising out of or in connection with: (a) improper selection, design, specification, application, or any misuse of Products; (b) any act or omission, negligent or otherwise, of Buyer; (c) Seller's use of patterns, tools, equipment, plans, drawings, designs, specifications or other information or things furnished by Buyer; (d) damage to the Products from an external cause, repair or attempted repair by anyone other than Seller, failure to follow instructions, guides and specifications provided by Seller, use with goods not provided by Seller, or opening, modifying, deconstructing, tampering with or repackaging the Products; or (e) Buyer's failure to comply with these Terms. Seller shall not indemnify Buyer under any circumstance except as otherwise provided in these Terms.

14. Cancellations and Changes. Buyer may not cancel or modify, including but not limited to movement of delivery dates for the Products, any order for any reason except with Seller's written consent and upon terms that will indemnify, defend and hold Seller harmless against all direct, incidental and consequential loss or damage and any additional expense. Seller, at any time, may change features, specifications, designs and availability of Products.

15. Limitation on Assignment. Buyer may not assign its rights or obligations without the prior written consent of Seller.

16. Force Majeure. Seller is not liable for delay or failure to perform any of its obligations by reason of events or circumstances beyond its reasonable control. Such circumstances include without limitation: accidents, labor disputes or stoppages, government acts or orders, acts of nature, pandemics, epidemics, other widespread illness, or public health emergency, delays or failures in delivery from carriers or suppliers, shortages of materials, war (whether declared or not) or the serious threat of same, riots, rebellions, acts of terrorism, fire or any reason whether similar to the foregoing or otherwise. Seller will resume performance as soon as practicable after the event of force majeure has been removed. All delivery dates affected by force majeure shall be tolled for the duration of such force majeure and rescheduled for mutually agreed dates as soon as practicable after the force majeure condition ceases to exist. Force majeure shall not include financial distress, insolvency, bankruptcy, or other similar conditions affecting one of the parties, affiliates and/or sub-contractors.

17. Waiver and Severability. Failure to enforce any provision of these Terms will not invalidate that provision; nor will any such failure prejudice either party's right to enforce that provision in the future. Invalidation of any provision of these Terms shall not invalidate any other provision herein and, the remaining provisions will remain in full force and effect.

18. Termination. Seller may terminate any agreement governed by or arising from these Terms for any reason and at any time by giving Buyer thirty (30) days prior written notice. Seller may immediately terminate, in writing, if Buyer: (a) breaches any provision of these Terms, (b) becomes or is deemed insolvent, (c) appoints or has appointed a trustee, receiver or custodian for all or any part of Buyer's property, (d) files a petition for relief in bankruptcy on its own behalf, or one is filed against Buyer by a third party, (e) makes an assignment for the benefit of creditors, or (f) dissolves its business or liquidates all or a majority of its assets.

19. Ownership of Software. Seller retains ownership of all Software supplied to Buyer hereunder. In no event shall Buyer obtain any greater right in and to the Software than a right in the nature of a license limited to the use thereof and subject to compliance with any other terms provided with the Software.

20. Indemnity for Infringement of Intellectual Property Rights. Seller is not liable for infringement of any patents, trademarks, copyrights, trade dress, trade secrets or similar rights ("Intellectual Property Rights") except as provided in this Section. Seller will defend at its expense and will pay the cost of any settlement or damages awarded in an action brought against Buyer based on a third party claim that one or more of the Products sold hereunder infringes the Intellectual Property Rights of a third party in the country of delivery of the Products by Seller to Buyer. Seller's obligation to defend and indemnify Buyer is contingent on Buyer notifying Seller within ten (10) days after Buyer becomes aware of any such claim, and Seller having sole control over the defense of the claim including all negotiations for settlement or compromise. If one or more Products sold hereunder is subject to such a claim, Seller may, at its sole expense and option, procure for Buyer the right to continue using the Products, replace or modify the Products so as to render them non-infringing, or offer to accept return of the Products and refund the purchase price less a reasonable allowance for depreciation. Seller has no obligation or liability for any claim of infringement: (i) arising from information provided by Buyer; or (ii) directed to any Products provided hereunder for which the designs are specified in whole or part by Buyer; or (iii) resulting from the modification, combination or use in a system of any Products provided hereunder. The foregoing provisions of this Section constitute Seller's sole and exclusive liability and Buyer's sole and exclusive remedy for claims of infringement of Intellectual Property Rights.

21. Governing Law. These Terms and the sale and delivery of all Products are deemed to have taken place in, and shall be governed and construed in accordance with, the laws of the State of Ohio, as applicable to contracts executed and wholly performed therein and without regard to conflicts of laws principles. Buyer irrevocably agrees and consents to the exclusive jurisdiction and venue of the courts of Cuyahoga County, Ohio with respect to any dispute, controversy or claim arising out of or relating to the sale and delivery of the Products.

22. Entire Agreement. These Terms, along with the terms set forth in the main body of any Quote, forms the entire agreement between the Buyer and Seller and constitutes the final, complete and exclusive expression of the terms of sale and purchase. In the event of a conflict between any term set forth in the main body of a Quote and these Terms, the terms set forth in the main body of the Quote shall prevail. All prior or contemporaneous written or oral agreements or negotiations with respect to the subject matter shall have no effect. These Terms may not be modified unless in writing and signed by an authorized representative of Seller.

23. Compliance with Laws. Buyer agrees to comply with all applicable laws, regulations, and industry and professional standards, including those of the United States of America, and the country or countries in which Buyer may operate, including without limitation the U.S. Foreign Corrupt Practices Act ("FCPA"), the U.S. Anti-Kickback Act ("Anti-Kickback Act"), U.S. and E.U. export control and sanctions laws ("Export Laws"), the U.S. Food Drug and Cosmetic Act ("FDCA"), and the rules and regulations promulgated by the U.S. Food and Drug Administration ("FDA"), each as currently amended. Buyer agrees to indemnify, defend, and hold harmless Seller from the consequences of any violation of such laws, regulations and standards by Buyer, its employees or agents. Buyer acknowledges that it is familiar with all applicable provisions of the FCPA, the Anti-Kickback Act, Export Laws, the FDCA and the FDA and certifies that Buyer will adhere to the requirements thereof and not take any action that would make Seller violate such requirements. Buyer represents and agrees that Buyer will not make any payment or give anything of value, directly or indirectly, to any governmental official, foreign political party or official thereof, candidate for foreign political office, or commercial entity or person, for any improper purpose, including the purpose of influencing such person to purchase Products or otherwise benefit the business of Seller. Buyer further represents and agrees that it will not receive, use, service, transfer or ship any Products from Seller in a manner or for a purpose that violates Export Laws or would cause Seller to be in violation of Export Laws. Buyer agrees to promptly and reliably provide Seller all requested information or documents, including end-user statements and other written assurances, concerning Buyer's ongoing compliance with Export Laws.



SAFETY GUIDE FOR SELECTING AND USING QUICK COUPLING DIVISION PRODUCTS AND RELATED ACCESSORIES



DANGER: Failure or improper selection or improper use of Quick Coupling Division (QCD) products and related accessories can cause death, personal injury, and property damage. Possible consequences of failure or improper selection or improper use of QCD products or related accessories include but are not limited to:

- Couplings or parts thrown off at high speed.
- High velocity fluid discharge.
- Explosion or burning of the conveyed fluid.
- Contact with suddenly moving or falling objects that are to be held in position or moved by the conveyed fluid.
- Dangerously whipping hose.
- Contact with conveyed fluids that may be hot, cold, toxic, or otherwise injurious.
- Sparking or explosion while paint or flammable liquid spraying.

Before selecting or using any Parker quick action couplings or related accessories, it is important that you read and follow the following instructions.

No product from the Quick Coupling Division is approved for in-flight aerospace applications. For products used in in-flight aerospace applications, please contact Parker Aerospace Group.

1.1 Scope: This safety guide provides instructions for selecting and using (including installing, connecting, disconnecting, and maintaining) QCD products and related accessories. This safety guide is a supplement to and is to be used with, the specific Parker publications for the specific QCD products and related accessories being considered for use.

1.2 Fail-Safe: QCD products or the hose they are attached to can fail without warning for many reasons. Design all systems and equipment in a fail-safe mode, so failure of the QCD product or hose will not endanger persons or property.

1.3 Distribution: Provide a copy of this safety guide to each person responsible for selecting or using QCD products. Do not select or use QCD products without thoroughly reading and understanding this safety guide as well as the specific Parker publications for the products considered or selected.

1.4 User Responsibility: Due to the wide variety of operating conditions and uses for QCD products, Parker and its distributors do not represent or warrant any particular QCD product suitable for any specific end use system. This safety guide does not analyze all technical parameters that must be considered in selecting a product. The user, through its own analysis and testing, is solely responsible for:

- Making the final selection of QCD products.
- Assuring the user's requirements are met and the use presents no health or safety hazards.
- Providing all appropriate health and safety warnings on the equipment on which the QCD products are used.

1.5 Additional Questions: Call the appropriate Parker customer service department if you have any questions or require any additional information. For the telephone numbers of the appropriate customer service department, see the Parker publication for the product being considered or used.

2.0 QCD PRODUCT SELECTION INSTRUCTIONS

2.1 Pressure: QCD product selection must be made so the published rated pressure is equal to or greater than the maximum system pressure. Surge pressures in the system higher than the rated pressure will shorten the QCD products' life. Do not confuse burst pressure or other pressure values with rated pressure and do not use burst pressure or other pressure values for this purpose.

2.2 Fluid Compatibility: QCD product selection must assure compatibility of the products' materials of construction with the fluid media being used.

2.3 Temperature: Be certain fluid and ambient temperatures, both steady and transient, do not exceed the limitations of the QCD product. Use caution and proper PPE when handling QCD products heated or cooled by the media they are conducting or by their environment.

2.4 Size: Transmission of power by means of pressurized liquid varies with pressure and flow. The size of the QCD product and other components of the system must be adequate pressure losses to a minimum and avoid damage due to heat generation or excessive fluid velocity.

2.5 Pressurized Connect or Disconnect: If connecting or disconnecting under pressure is a requirement, use only quick couplings designed for that purpose. The rated operating pressure of a quick action coupling may not be the pressure at which it may be safely connected or disconnected.

2.6 Environment: Care must be taken to ensure QCD products are either compatible with or protected from the environment (that is, surrounding conditions) to which they are exposed. Environmental conditions including but not limited to ultraviolet radiation, ozone, moisture, water, salt water, chemicals, and air pollutants can cause degradation and premature failure.

Safety Guide

2.7 Locking Means: Ball locking quick couplings can unintentionally disconnect if they are dragged over obstructions on the end of a hose or if the sleeve is bumped or moved enough to cause disconnect. Sleeves designed with flanges to provide better ripping for oily or gloved hands are especially susceptible to accidental disconnect and should not be used where these conditions exist. Sleeve lock or union (threaded) sleeve designs should be considered where there is a potential for accidental disconnect.

2.8 Mechanical Loads: External forces can significantly reduce QCD product life or cause failure. Mechanical loads which must be considered include excessive tensile or side loads, and vibration. Unusual applications may require special testing prior to QCD product selection.

2.9 Specifications and Standards: When selecting QCD products, government, industry, and Parker specifications must be reviewed and followed where applicable.

2.10 Vacuum: Not all QCD products are suitable or recommended for vacuum service. QCD products used for vacuum applications must be selected to ensure the product will withstand the vacuum and pressure of the system.

2.11 Fire Resistant Fluids: Some fire-resistant fluids require seals other than the standard nitrile used in many QCD products.

2.12 Radiant Heat: QCD product can be heated to destruction or loss of sealing integrity without contact by nearby items such as hot manifolds or molten metal. The same heat source may then initiate a fire. This can occur despite the presence of cool air around the QCD product.

2.13 Welding and Brazing: Heating of plated parts, including QCD products and port adapters, above 450°F (232°C) such as during welding, brazing, or soldering may emit deadly gases and may cause permanent product damage.

3.0 QUICK ACTION COUPLING INSTALLATION INSTRUCTIONS

3.1 Pre-Installation Inspection: Before installing a QCD product, visually inspect it and check for correct style, body material, seal material, and catalog number. Before final installation, coupling halves should be connected and disconnected with a sample of the mating half with which they will be used.

3.2 Quick Coupling Halves from Other Manufacturers: If a quick coupling assembly is made up of one Parker half and one half from another manufacturer, the lowest pressure rating of the two halves should not be exceeded.

3.3 Fitting Installation: Use a thread sealant, lubricant, or a combination of both when assembling pipe thread joints on QCD products. Be sure the sealant is compatible with the system fluid or gas. To avoid system contamination, use a liquid or paste type sealant rather than a tape style. Use the flats provided to hold QCD product when installing fittings. Do not use pipe wrenches or a vice on other parts of the product

to hold it when installing or removing fittings as damage or loosening of threaded assembly joints in the product could result. Do not apply excessive torque to taper pipe threads because cracking or splitting of the female component can result.

3.4 Caps and Plugs: Use dust caps and plugs when quick couplings are not coupled to exclude dirt and contamination and to protect critical surfaces from damage.

3.5 Quick Coupling Location: Locate quick couplings where they can be reached for connect or disconnect without exposing the operator to slipping, falling, getting sprayed, or coming in contact with hot or moving parts.

3.6 Hose Whips: Use a hose whip (a short length of hose between the tool and the coupling half) instead of rigidly mounting a coupling half on hand tools or other devices. This reduces the potential for coupling damage if the tool is dropped and provides some isolation from mechanical vibration which could cause unintended disconnection.

4.0 QCD PRODUCT MAINTENANCE INSTRUCTIONS

4.1 Even with proper selection and installation, QCD product life may be significantly reduced without a maintenance program. Frequency should be determined by the severity of the application and risk potential. A maintenance program must be established and followed by the user and must include the following as a minimum:

4.2 Visual Inspection of QCD Product: Any of the following conditions require immediate shut down and replacement of the QCD product:

- Cracked, damaged, or corroded product.
- Leaks at the fitting, valve or mating seal.
- Broken mounting hardware, especially breakaway clamps.

4.3 Visual Inspection Other: The following items must be tightened, repaired or replaced as required:

- Leaking seals or port connections.
- Excess dirt buildup on the quick coupling locking mechanism or on the interface area of either coupling half
- Clamps, guards, and shields.
- System fluid level, fluid type and any air entrapment.

4.4 Functional Test: Operate the system at maximum operating pressure and check for possible malfunctions and leaks. Personnel must avoid potentially hazardous areas while testing and using the system.

4.5 Replacement Intervals: Specific replacement intervals must be considered based on previous service life, government, or industry recommendations, or when failures could result in unacceptable downtime, damage, or injury risk. See instruction 1.2 above.

Additional copies of the preceding safety information can be ordered by requesting "Safety Guide for Selecting and Using QCD Product and Related Accessories," Parker Publication DS6013.

Contact Parker's Quick Coupling Division, Minneapolis, MN.



Parker Fluid Connectors Group

Your complete source for quality tube fittings, hose & hose fittings, brass & composite fittings, quick-disconnect couplings, valves, and assembly tools, locally available from a worldwide network of authorized distributors.

Fittings:

Available in inch and metric sizes covering SAE, BSP, DIN, GAZ, JIS, and ISO thread configurations, manufactured from steel, stainless steel, brass, aluminum, nylon, and thermoplastic.

Hose, Tubing, and Bundles:

Available in a wide variety of sizes and materials including rubber, wire-reinforced, thermoplastic, hybrid and custom compounds.

Worldwide Availability:

Parker operates Fluid Connectors manufacturing locations and sales offices throughout North America, South America, Europe, and Asia-Pacific.

For more information on

SensoNODE and Voice of the Machine products:

Visit: Parker.com/ConditionMonitoring

Call: (763) 544-7781

For more information on

SensoControl Wired Diagnostic and Control products:

Visit: Parker.com/SensoControl

Call: (763) 544-7781

Have questions or need help? Sign into our Condition Monitoring Service Desk.

Solutions.Parker.com/loT-Support

Sales of **SensoNODE** Sensors and **Voice of the Machine** Software in U.S., Canada and Europe. Consult QCD for other regions.

