

# Mobile Reverse Osmosis System Light Weight H2O-Pro



The Light Weight H2O-PRO unit provides fresh water from any water source, including seawater. The Light Weight H2O-PRO will process 25 gallons per hour from 24 VDC or Power Supplies available in 120 or 220 VAC power.

Key Features:

- Cleanable Light weight prefilter
- Reverse Osmosis system



Light Weight H2O Pro

## Contact Information:

Parker Hannifin Corporation  
**Water Purification**  
2630 E. El Presidio Street  
Carson, CA 90810

**phone 310 608 5600**  
**fax 310 608 5692**  
**waterpurification@parker.com**

**Website:**  
[www.parker.com/waterpurification](http://www.parker.com/waterpurification)

**Sales:**  
[waterpurification@parker.com](mailto:waterpurification@parker.com)

**Tech Support:**  
[watertech@parker.com](mailto:watertech@parker.com)

## Key Features:

- Simple Operation
- Extremely energy efficient
- Quick set-up
- Light weight
- 100% tool-less maintenance
- Rugged military proven design



ENGINEERING YOUR SUCCESS.

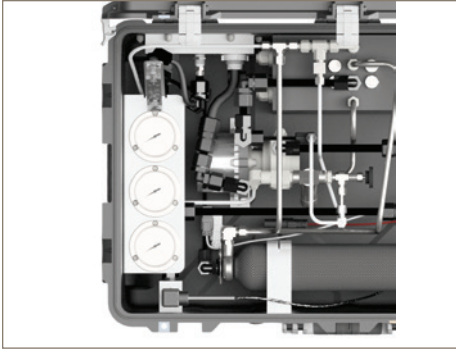

Inside Instrument Panel

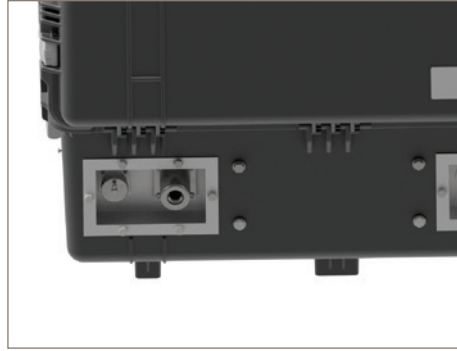

Power Conn. Ports



External Water Connections

- Energy efficient - less than 700 Watts on Seawater or 400 Watts on Freshwater
- Quiet operation - less than 65dB
- Operate with case close for harsh environments
- Cleanable filters for simplified maintenance.
- Ultra simple tool - less membrane change out
- Cleanable Light weight Prefilter for source water up to 250 NTU
- Auxiliary Case contains AC & Battery power supplies, water test kit, spare parts, cables and hoses.

## Specifications

Model	Part No.	Capacity	Power	Weight	Dimension (LWH)
Light Weight H20 Pro	0500141	25 GPH 95 LPH	24 VDC & 120/220 VAC	85 lbs X 2 cases (38 kg)	31.7" x 23.5" x 12.7" (805 x 597 x 322 mm)

### **⚠ WARNING - USER RESPONSIBILITY**

**FAILURE OR IMPROPER SELECTION OR IMPROPER USE OF THE PRODUCTS DESCRIBED HEREIN OR RELATED ITEMS CAN CAUSE DEATH, PERSONAL INJURY AND PROPERTY DAMAGE.**

- This document and other information from Parker-Hannifin Corporation, its subsidiaries and authorized distributors provide product or system options for further investigation by users having technical expertise.
- The user, through its own analysis and testing, is solely responsible for making the final selection of the system and components and assuring that all performance, endurance, maintenance, safety and warning requirements of the application are met. The user must analyze all aspects of the application, follow applicable industry standards, and follow the information concerning the product in the current product catalog and in any other materials provided from Parker or its subsidiaries or authorized distributors.
- To the extent that Parker or its subsidiaries or authorized distributors provide component or system options based upon data or specifications provided by the user, the user is responsible for determining that such data and specifications are suitable and sufficient for all applications and reasonably foreseeable uses of the components or systems.