



FAP/FAPC

Proportional Poppet Valves



ENGINEERING YOUR SUCCESS.

Introducing...

FAP/FAPC Proportional Poppet Valves



A new low-leak proportional flow control family!

Parker Hydraulic Cartridge Systems Division combines Parker's precision ground poppet and SuperCoil technology with a newly patented integral compensator design, bringing you a flow control product with ***best in class repeatability and a truly exceptional level of control.***

Parker's innovative new flow control products are available in both compensated (FAPC) and non-compensated (FAP) series product families. The FAP series offers repeatable and accurate operation throughout the full control range of the valve. In conditions of varying load, the FAPC series maintains predictable and repeatable performance through the introduction of our new fully integrated compensator.

Built directly into the FAPC series valves, the innovative new compensator maintains a tight seal for load holding without any requirement for additional sealing. When open, the compensator responds to changing load conditions independently. With no seal friction to overcome, the FAPC valve maintains the repeatable and predictable performance customers can rely on. This additional feature eliminates the need for complex programming algorithms, and any requirement for an external compensator to improve the operator's control.

The FAP and FAPC valve series excel in low flow metering conditions, where control of your equipment is most critical.

Have questions? Contact us at HCSInfo@parker.com.



Features & Benefits

The new FAP and FAPC family is a natural fit in lifting and lowering applications where holding the load and controlling movement leaves little margin for error. The fully compensated FAPC is rated to flows up to 115 LPM (22 GPM); while the non-compensated FAP is capable of flows up to 120 LPM (28 GPM). High flow capability doesn't come at the expense of critical control on the low end of the flow range.

Repeatable Control

Programming the FAP and FAPC is easy due to a more linear flow curve in relation to input current. This linearity combined with low internal hysteresis allows for more repeatable performance and lower variability from valve to valve.

Superior Metering

An added benefit of the smooth linear flow curve is precision control in low flow requirements, where control accuracy matters most. Less internal friction and more predictable control give the FAP and FAPC products "outstanding control, right out of the box."

Modular Solution

Multi-functional by design the FAP and FAPC pack more features into a single cavity. Proportional control when open, low leak load holding when desired with pressure compensation available for conditions of varying load.



FAP

- Excellent metering capability and control throughout the full flow range
- Reduced drift
- Low leak control (less than 5 dpm)
- Modular solution to applied problem
- Improved control throughout the control range

FAPC

- Excellent metering capability and control throughout the full flow range
- Reduced drift
- Low leak control (less than 5 dpm)
- Modular solution to applied problem
- Low leak compensator, requiring no additional seals, results in very low hysteresis (< 10%)
- Maintains constant flow regardless of load condition
- Patented Integrated low leak compensator

“Outstanding control, right out of the box.”

For more technical details please consult our catalog pages available on our website www.parker.com/hcs or by emailing us at HCSinfo@parker.com.



FAP - How it works

The FAP utilizes a control current to proportionally raise and lower a poppet creating a variable orifice allowing flow to pass through from the inlet to the outlet.

FAP At Rest:

No pressure is present at the cartridge.

The armature spring pushes the pilot against the poppet and the poppet against the seat, holding the valve closed.

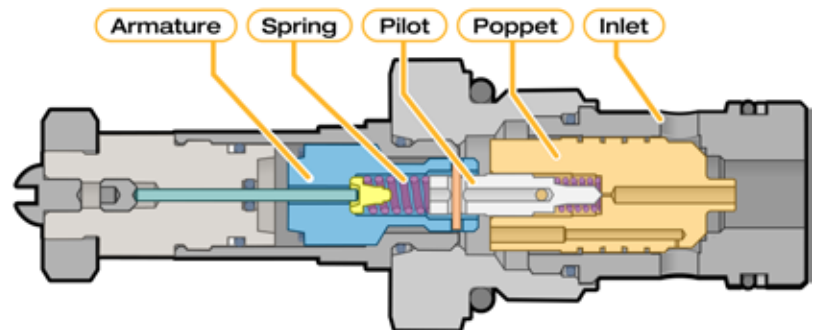

FAP Pressure Applied:

When pressure is applied to the inlet port, the poppet is against the seat as it is when no pressure is available at rest.

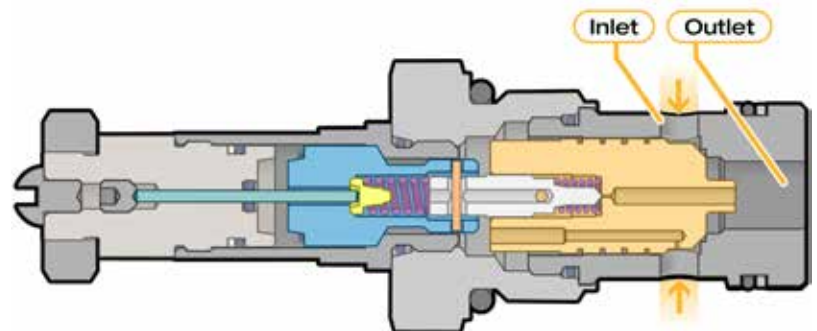

FAP Current Applied:

As current is applied to the coil, the armature moves proportionally to the current applied. This lifts the pilot off the poppet.

The poppet then follows the displacement of the pilot and lifts off the seat.

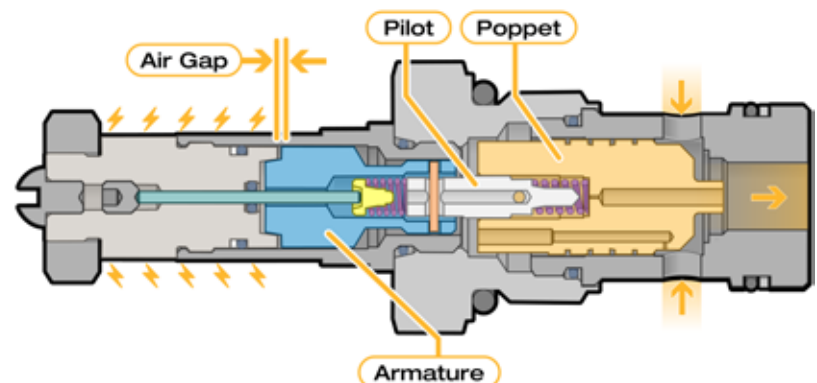

FAPC - How it works

The FAPC utilizes a control current to proportionally raise and lower a poppet creating a variable orifice allowing flow to pass through from the inlet to the outlet. There is also a low leak integral compensator that responds to load changes in the hydraulic circuit by varying the outlet orifice, metering the flow rate that can be passed through and maintaining constant flow independent of load conditions.

FAPC At Rest:

No pressure present at the cartridge. The armature spring pushes the pilot against the poppet and the poppet against the seat, holding the valve closed.

The compensator spring pushes the compensator spool to the open position.

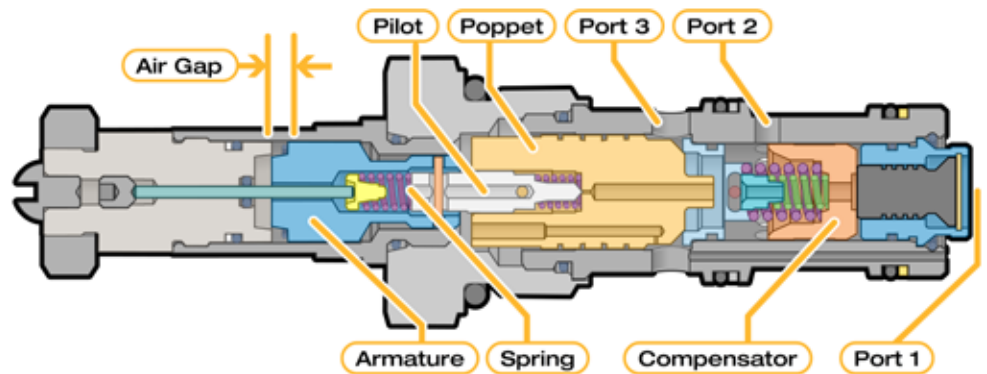

FAPC Pressure Applied:

When pressure is applied to the inlet port, the poppet is against the seat as it is when no pressure is available at rest.

Pressure at the inlet is also communicated to port 1 through an internal passage. The pressure pushes the piston against the seat to prevent leakage from the inlet to the outlet, preventing actuator movement.

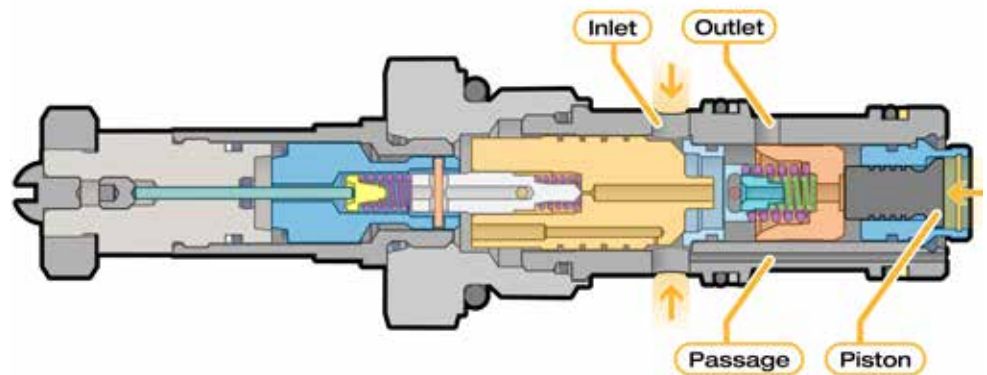

FAPC Current Applied:

As current is applied to the coil, the armature moves proportionally to the current applied. This lifts the pilot off the poppet. The poppet then follows the displacement of the pilot and lifts off the seat.

The compensator moves to maintain a constant pressure drop across the poppet and seat which maintains a constant flow rate regardless of inlet pressure changes.

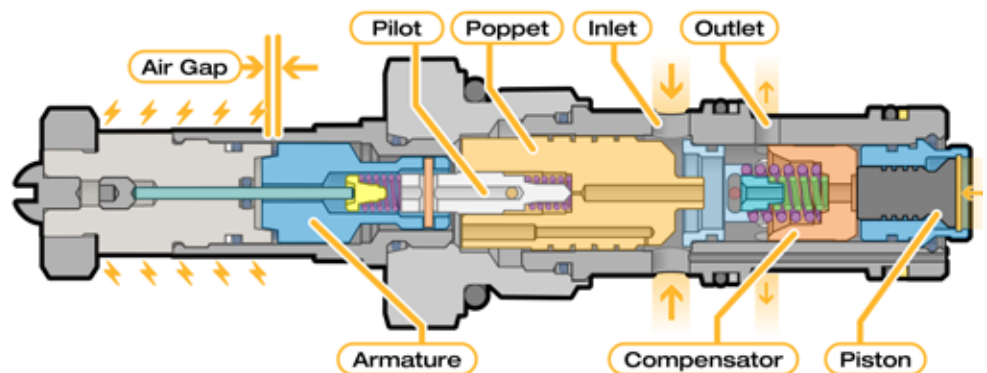

Markets and Applications



Application Examples

Poppet type proportional valves can be configured in a bridge circuit arrangement to create virtually any proportional spool condition. The valve timing can be individually controlled to provide decompression, cushion start or stop, or cylinder regeneration functions. Electronic feedback based on cylinder position or load pressure can be used to control cylinder position, speed, or to control the drop out of regeneration function.

Function	1	2	3	4	5	6
	C	C	C	C	C	C
	O	O	O	O	C	C
	O	O	O	C	C	C
	C	C	O	O	C	C
	O	C	C	O	C	C
	C	O	O	C	C	C
	C	C	C	C	O	C
	O	C	C	C	C	O
	C	O	C	C	C	C
	C	C	O	C	C	C

O = Open Valve Condition
C = Closed Valve Condition

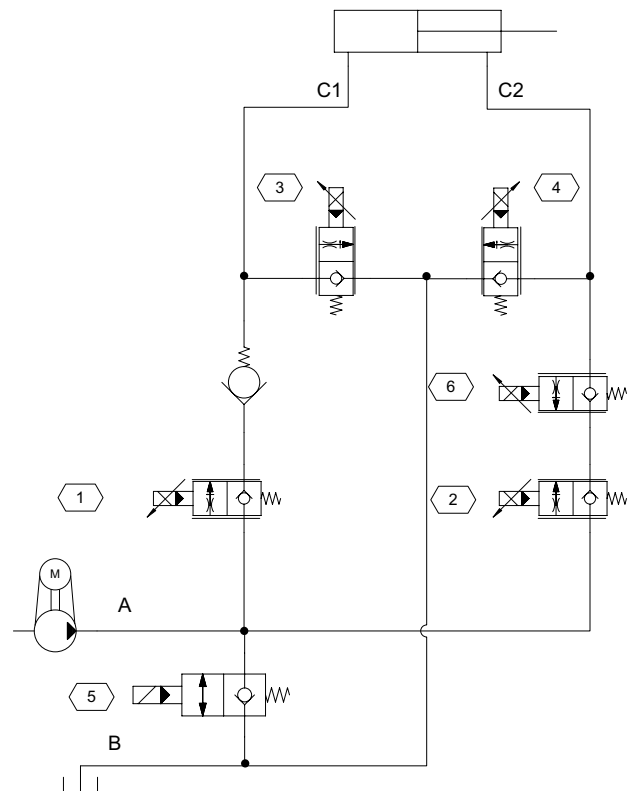

Lift Trucks Aerial Work Platforms Scissor Lift Utility Harvesting Combines Vehicle Suspension ... are just some of the applications



Normally closed FAPC used as a proportional lift and lower control. The low leak compensator and spherical poppet act to hold the load in the closed position. The valve is shifted proportionally to control lift or lower speed.

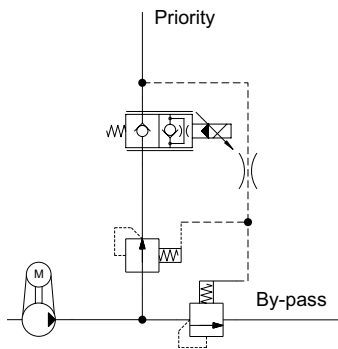
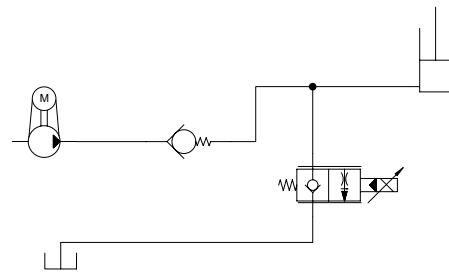

FAP and Logic valves used as a proportional compensated flow control with by-pass. Priority flow is proportionally controlled by the FAP across the compensator. When the priority flow rate is met, the valve allows additional flow available from the pump to by-pass to another function.

FAPC normally closed used in combination with load control valves for header height or suspension control. Holds suspended load at set height over rough terrain.

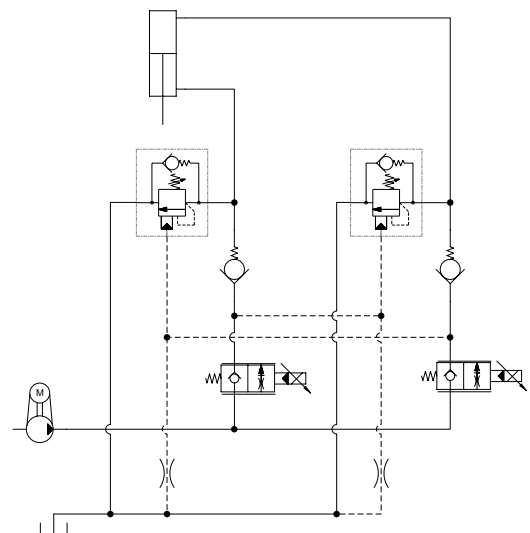

Discover how Parker HCS can be the ONE source for all your hydraulic cartridge and manifold needs.

Contact us at HCSInfo@parker.com for more info.



Parker Hannifin - Hydraulic Cartridge Systems

Parker Hannifin Corporation
Hydraulic Cartridge Systems
595 Schelter Road
Lincolnshire, IL 60069
USA
phone 847 955 5000
fax 847 383 8905
www.parker.com/hcs

Parker Hannifin Ltd.
**Hydraulic Cartridge
Systems Europe**
Blacknell Lane
Crewkerne, Somerset
TA18 8LL, UK
phone +44 (0) 1460 271800
fax +44 (0) 1460 271801

Parker Hannifin Corporation
Corporate Headquarters
6035 Parkland Blvd
Cleveland, OH 44124
USA
Tel: 216-896-3000
Fax: 216-896-4000

For information, please contact Parker toll free at 1-800-C-PARKER (1-800-272-7537). Outside of North America contact us via Freephone at 00800 27 27 5374.



Parker Hannifin Corporation
Hydraulic Cartridge Systems Division
595 Schelter Road
Lincolnshire, IL 60069
phone 847 955 5000
fax 847 383 8900
www.parker.com/hcs
hcsinfo@parker.com