

**Technical Information**

- CV** Check Valves
- SH** Shuttle Valves
- LM** Load/Motor Controls
- FC** Flow Controls
- PC** Pressure Controls
- LE** Logic Elements
- DC** Directional Controls
- MV** Manual Valves
- SV** Solenoid Valves
- PV** Proportional Valves
- CE** Coils & Electronics
- BC** Bodies & Cavities
- TD** Technical Data

**General Description**

Pilot Operated Pressure Reducing/Relieving Valve. For additional information see Technical Tips on pages PC1-PC6.



**Features**

- Hardened, precision ground parts for durability
- Low profile adapter for minimal space requirements
- Fully guided pilot for more consistent reseal
- Steel adapters are zinc plated
- Polyurethane "D"-Ring eliminates backup rings and prevents hydrolysis
- Internal screening protects pilot spring from debris

**Specifications**

<b>Rated Flow</b>	30 LPM (8 GPM)								
<b>Maximum Inlet Pressure</b>	380 Bar (5500 PSI)								
<b>Maximum Pressure Setting</b>	350 Bar (5000 PSI)								
<b>Sensitivity: Pressure/Turn</b>	<table style="border: none;"> <tr> <td><b>10</b></td> <td>19.6 Bar (285 PSI)</td> </tr> <tr> <td><b>20</b></td> <td>39.3 Bar (570 PSI)</td> </tr> <tr> <td><b>30</b></td> <td>58.9 Bar (859 PSI)</td> </tr> <tr> <td><b>50</b></td> <td>131.7 Bar (1910 PSI)</td> </tr> </table>	<b>10</b>	19.6 Bar (285 PSI)	<b>20</b>	39.3 Bar (570 PSI)	<b>30</b>	58.9 Bar (859 PSI)	<b>50</b>	131.7 Bar (1910 PSI)
<b>10</b>	19.6 Bar (285 PSI)								
<b>20</b>	39.3 Bar (570 PSI)								
<b>30</b>	58.9 Bar (859 PSI)								
<b>50</b>	131.7 Bar (1910 PSI)								
<b>Maximum Tank Pressure</b>	350 Bar (5000 PSI)								
<b>Maximum Drain Flow</b>	0.56 LPM (0.15 GPM)								
<b>Cartridge Material</b>	All parts steel. All operating parts hardened steel.								
<b>Operating Temp. Range/Seals</b>	-45°C to +132°C ("D"-Ring) (-50°F to +270°F) -34°C to +121°C (Nitrile) (-30°F to +250°F) -26°C to +204°C (Fluorocarbon) (-15°F to +400°F)								
<b>Fluid Compatibility/Viscosity</b>	Mineral-based or synthetic with lubricating properties at viscosities of 45 to 2000 SSU (6 to 420 cSt)								
<b>Filtration</b>	ISO-4406 18/16/13, SAE Class 4								
<b>Approx. Weight</b>	.11 kg (.25 lbs.)								
<b>Cavity</b>	C08-3 (See BC Section for more details)								
<b>Form Tool</b>	<table style="border: none;"> <tr> <td>Rougher</td> <td>NTF08-3R</td> </tr> <tr> <td>Finisher</td> <td>NFT08-3F</td> </tr> </table>	Rougher	NTF08-3R	Finisher	NFT08-3F				
Rougher	NTF08-3R								
Finisher	NFT08-3F								

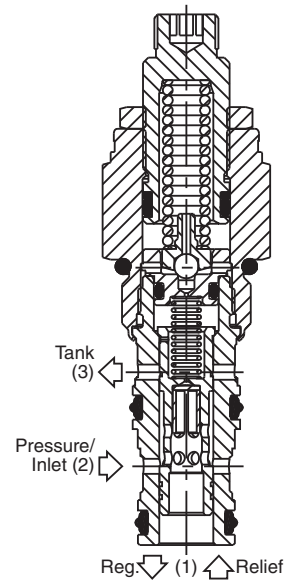
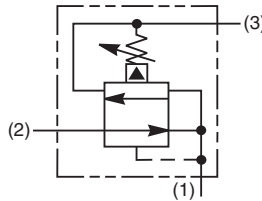

**Performance Curves**

**Flow vs. Regulated Pressure (Through cartridge only)**

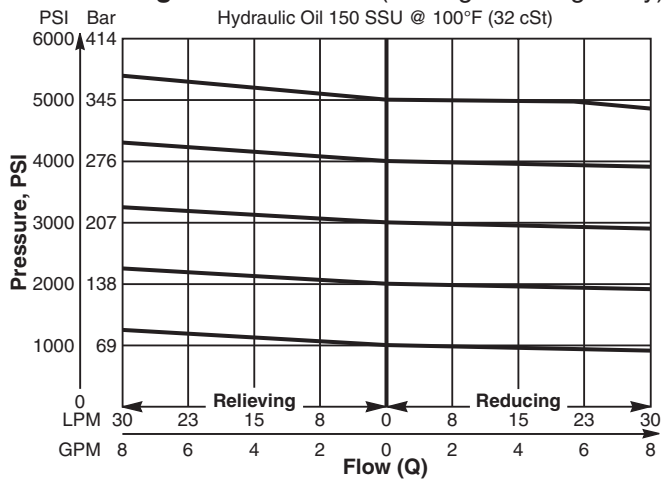

**Flow vs. Pressure Drop (Through cartridge only)**

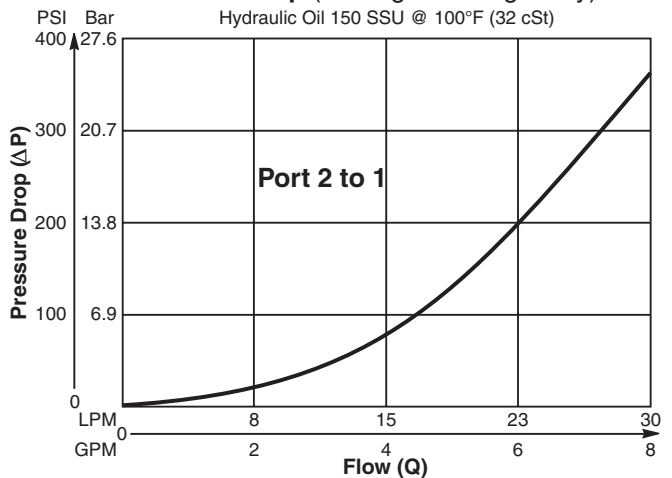

**Dimensions** Millimeters (Inches)

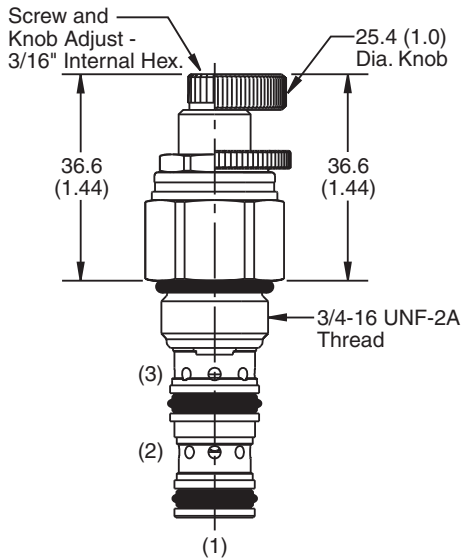

**Screw/Knob Version**

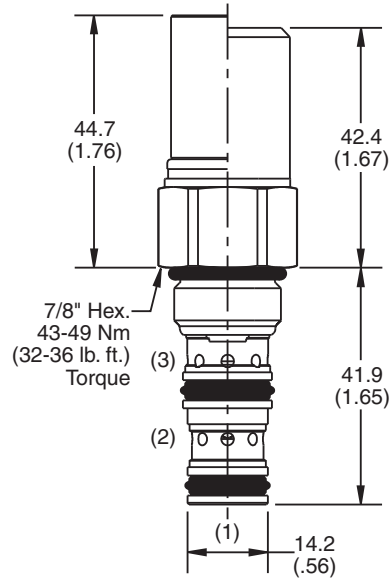

**Fixed Cap/Tamper Resistant Version**

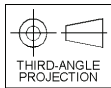

**Ordering Information**

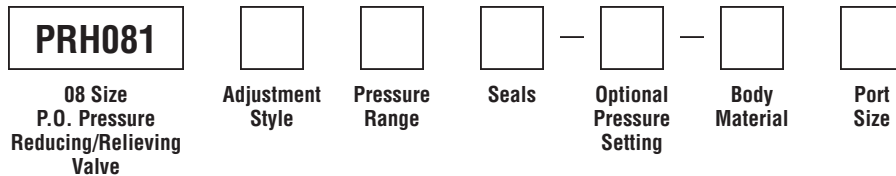

Code	Adjustment Style / Kit No.
F	Fixed style, preset at factory.
K	Knob Adjust (717784-10)
S	Screw Adjust
T	Tamper Resistant Cap (717943)

Code	Seals / Kit No.
Omit	"D"-Ring / (SK08-3)
N	Nitrile / (SK08-3N)
V	Fluorocarbon / (SK08-3V)

Code	Body Material
Omit	Steel
A	Aluminum

Code	Pressure Range
10	6.9 - 69 Bar (100 - 1000 PSI) Standard Setting: 34.5 Bar (500 PSI)
20	6.9 - 138 Bar (100 - 2000 PSI) Standard Setting: 69 Bar (1000 PSI)
30	13.8 - 207 Bar (200 - 3000 PSI) Standard Setting: 103.5 Bar (1500 PSI)
50	13.8 - 345 Bar (200 - 5000 PSI) Standard Setting: 172.4 Bar (2500 PSI)

Optional Pressure Setting
Pressure ÷ 10 i.e. 235 = 2350 PSI (Omit if standard setting is used) Setting Range: 100 to 5000 PSI

Code	Port Size	Body Part No.
Omit	Cartridge Only	
4T	SAE-4	(B08-3-*4T)
6T	SAE-6	(B08-3-*6T)

\* Add "A" for aluminum, omit for steel.

**NOTE:** For settings below 20.7 Bar (300 PSI), flow rating is limited to 11.3 LPM (3 GPM).

- CV  
Check Valves
- SH  
Shuttle Valves
- LM  
Load/Motor Controls
- FC  
Flow Controls
- PC  
Pressure Controls
- LE  
Logic Elements
- DC  
Directional Controls
- MV  
Manual Valves
- SV  
Solenoid Valves
- PV  
Proportional Valves
- CE  
Coils & Electronics
- BC  
Bodies & Cavities
- TD  
Technical Data