

**Technical Information**

- CV** Check Valves
- SH** Shuttle Valves
- LM** Load/Motor Controls
- FC** Flow Controls
- PC** Pressure Controls
- LE** Logic Elements
- DC** Directional Controls
- MV** Manual Valves
- SV** Solenoid Valves
- PV** Proportional Valves
- CE** Coils & Electronics
- BC** Bodies & Cavities
- TD** Technical Data

**General Description**

Pilot Operated Pressure Reducing/Relieving Valve. For additional information see Technical Tips on pages PC1-PC6.

**Features**

- Hardened, precision ground parts for durability
- Ball-type pilot for added stability
- Full capacity reducing/relieving
- Performs job of two separate valves in one
- All external parts zinc plated

**Specifications**

<b>Rated Flow</b>	150 LPM (40 GPM)								
<b>Maximum Inlet Pressure</b>	380 Bar (5500 PSI)								
<b>Maximum Pressure Setting</b>	350 Bar (5000 PSI)								
<b>Sensitivity: Pressure/Turn</b>	<table style="border: none;"> <tr> <td style="padding-right: 10px;"><b>10</b></td> <td>23 Bar (334 PSI)</td> </tr> <tr> <td><b>20</b></td> <td>37 Bar (539 PSI)</td> </tr> <tr> <td><b>30</b></td> <td>60 Bar (870 PSI)</td> </tr> <tr> <td><b>50</b></td> <td>118 Bar (1711 PSI)</td> </tr> </table>	<b>10</b>	23 Bar (334 PSI)	<b>20</b>	37 Bar (539 PSI)	<b>30</b>	60 Bar (870 PSI)	<b>50</b>	118 Bar (1711 PSI)
<b>10</b>	23 Bar (334 PSI)								
<b>20</b>	37 Bar (539 PSI)								
<b>30</b>	60 Bar (870 PSI)								
<b>50</b>	118 Bar (1711 PSI)								
<b>Maximum Tank Pressure</b>	350 Bar (5000 PSI)								
<b>Maximum Drain Flow</b>	1.9 LPM (0.5 GPM)								
<b>Cartridge Material</b>	All parts steel. All operating parts hardened steel.								
<b>Operating Temp. Range/Seals</b>	-34°C to +121°C (Nitrile) (-30°F to +250°F) -26°C to +204°C (Fluorocarbon) (-15°F to +400°F)								
<b>Fluid Compatibility/Viscosity</b>	Mineral-based or synthetic with lubricating properties at viscosities of 45 to 2000 SSU (6 to 420 cSt)								
<b>Filtration</b>	ISO-4406 18/16/13, SAE Class 4								
<b>Approx. Weight</b>	0.9 kg (2.0 lbs.)								
<b>Cavity</b>	C16-3 (See BC Section for more details)								
<b>Form Tool</b>	<table style="border: none;"> <tr> <td>Rougher</td> <td>NTF16-3R</td> </tr> <tr> <td>Finisher</td> <td>NFT16-3F</td> </tr> </table>	Rougher	NTF16-3R	Finisher	NFT16-3F				
Rougher	NTF16-3R								
Finisher	NFT16-3F								

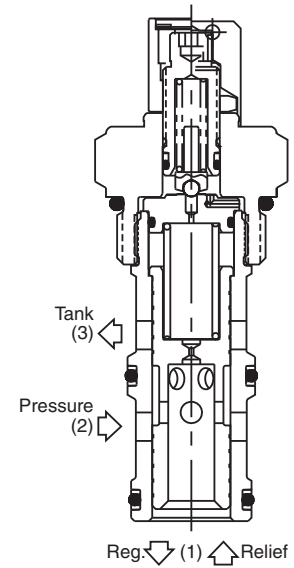
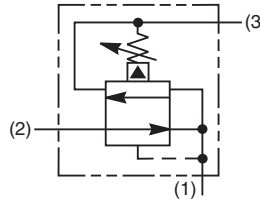

**Performance Curve**

**Flow vs. Regulated Pressure**

(Pressure rise through cartridge only)

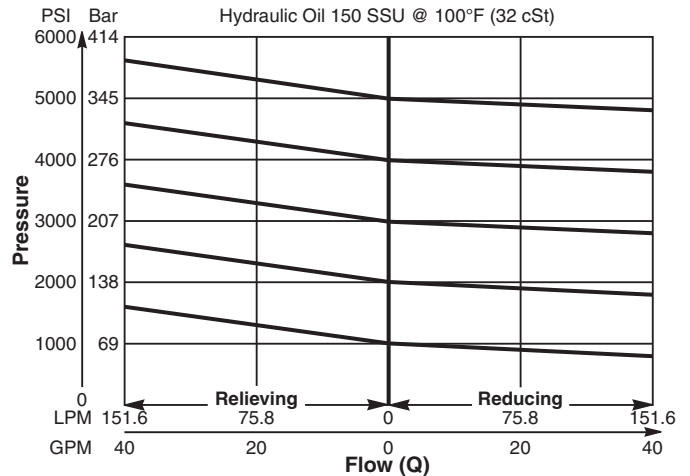

**Dimensions** Millimeters (Inches)

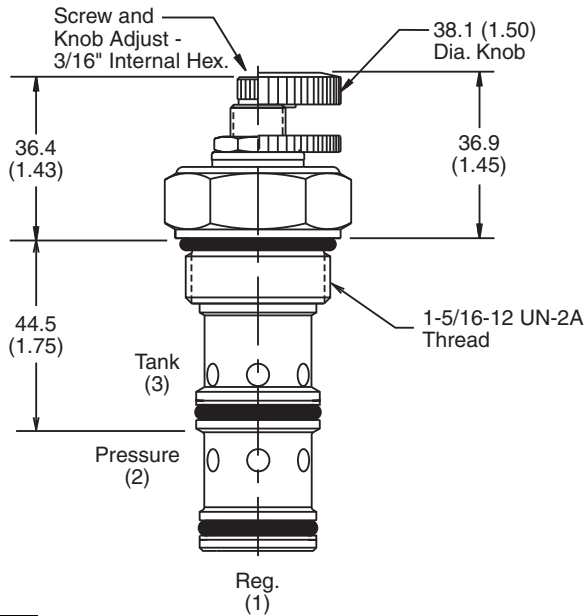

**Screw/Knob Version**

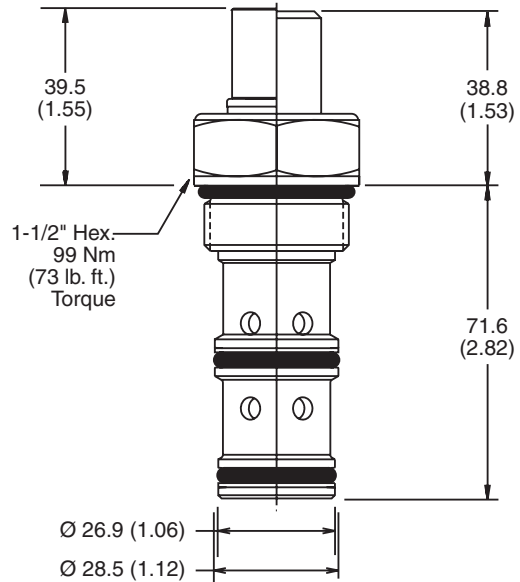

**Fixed Cap/Tamper Resistant Version**

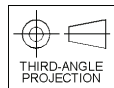

**Ordering Information**

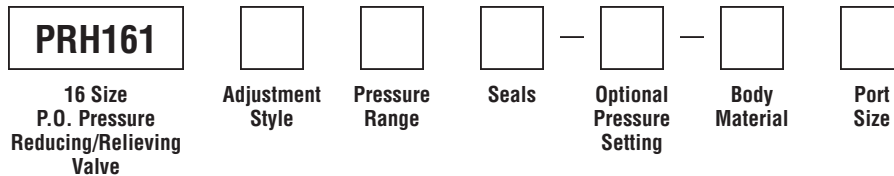

Code	Adjustment Style / Kit No.
F	Fixed style, preset at factory.
K	Knob Adjust (717784-15)
S	Screw Adjust
T	Tamper Resistant Cap (717785)

Code	Seals / Kit No.
Omit	Nitrile / (SK16-3)
V	Fluorocarbon / (SK16-3V)

Code	Body Material
Omit	Steel
A	Aluminum

Code	Pressure Range
10	6.9 - 69 Bar (100 - 1000 PSI) Standard Setting: 34.5 Bar (500 PSI)
20	13.8 - 138 Bar (200 - 2000 PSI) Standard Setting: 69 Bar (1000 PSI)
30	20.7 - 207 Bar (300 - 3000 PSI) Standard Setting: 103.5 Bar (1500 PSI)
50	34.5 - 345 Bar (500 - 5000 PSI) Standard Setting: 172.4 Bar (2500 PSI)

Optional Pressure Setting
Pressure ÷ 10 i.e. 235 = 2350 PSI (Omit if standard setting is used) Setting Range: 100 to 5000 PSI

Code	Port Size	Body Part No.
Omit	Cartridge Only	
12T	SAE-12	(B16-3-*12T)
16T	SAE-16	(B16-3-*16T)

\* Add "A" for aluminum, omit for steel.

- CV  
Check Valves
- SH  
Shuttle Valves
- LM  
Load/Motor Controls
- FC  
Flow Controls
- PC  
Pressure Controls
- LE  
Logic Elements
- DC  
Directional Controls
- MV  
Manual Valves
- SV  
Solenoid Valves
- PV  
Proportional Valves
- CE  
Coils & Electronics
- BC  
Bodies & Cavities
- TD  
Technical Data