

Technical Information

- CV** Check Valves
- SH** Shuttle Valves
- LM** Load/Motor Controls
- FC** Flow Controls
- PC** Pressure Controls
- LE** Logic Elements
- DC** Directional Controls
- MV** Manual Valves
- SV** Solenoid Valves
- PV** Proportional Valves
- CE** Coils & Electronics
- BC** Bodies & Cavities
- TD** Technical Data

General Description

Pilot Operated Pressure Reducing Valve. For additional information see Technical Tips on pages PC1-PC6.

Features

- Hardened, precision ground parts for durability
- High accuracy, pilot operation design
- Ball-type pilot for added stability
- All external parts zinc plated

Specifications

Rated Flow	150 LPM (40 GPM)								
Maximum Inlet Pressure	380 Bar (5500 PSI)								
Maximum Pressure Setting	350 Bar (5000 PSI)								
Sensitivity: Pressure/Turn	<table border="0"> <tr> <td>10</td> <td>23 Bar (334 PSI)</td> </tr> <tr> <td>20</td> <td>37 Bar (539 PSI)</td> </tr> <tr> <td>30</td> <td>60 Bar (870 PSI)</td> </tr> <tr> <td>50</td> <td>118 Bar (1711 PSI)</td> </tr> </table>	10	23 Bar (334 PSI)	20	37 Bar (539 PSI)	30	60 Bar (870 PSI)	50	118 Bar (1711 PSI)
10	23 Bar (334 PSI)								
20	37 Bar (539 PSI)								
30	60 Bar (870 PSI)								
50	118 Bar (1711 PSI)								
Maximum Tank Pressure	350 Bar (5000 PSI)								
Maximum Drain Flow	0.94 LPM (0.25 GPM)								
Cartridge Material	All parts steel. All operating parts hardened steel.								
Operating Temp. Range/Seals	-34°C to +121°C (Nitrile) (-30°F to +250°F) -26°C to +204°C (Fluorocarbon) (-15°F to +400°F)								
Fluid Compatibility/Viscosity	Mineral-based or synthetic with lubricating properties at viscosities of 45 to 2000 SSU (6 to 420 cSt)								
Filtration	ISO-4406 18/16/13, SAE Class 4								
Approx. Weight	0.9 kg (2.0 lbs.)								
Cavity	C16-3 (See BC Section for more details)								
Form Tool	Rougher NTF16-3R Finisher NFT16-3F								

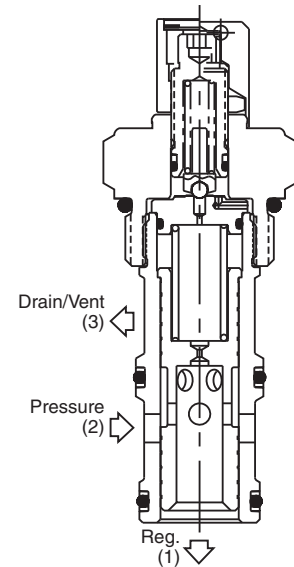
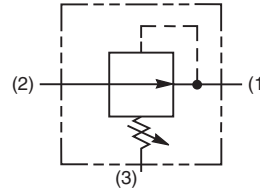

Performance Curve

Flow vs. Pressure

(Pressure rise through cartridge only)

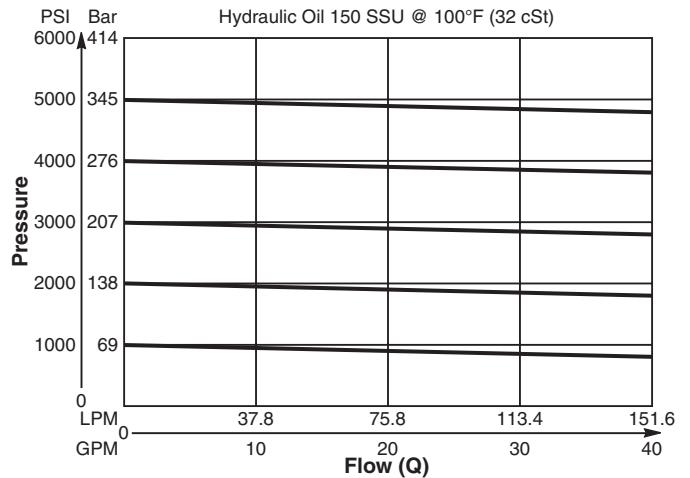

Dimensions Millimeters (Inches)

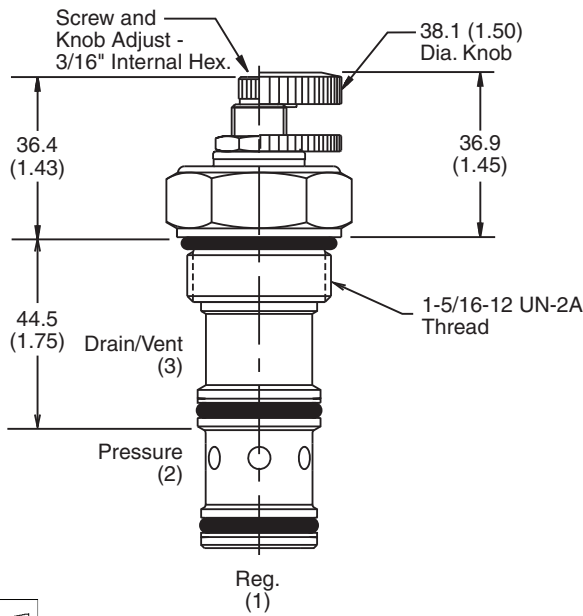

Screw/Knob Version

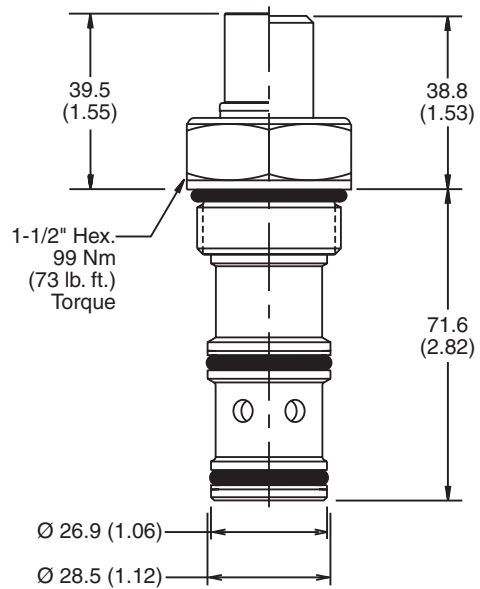

Fixed Cap/Tamper Resistant Version

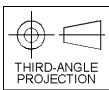

Ordering Information

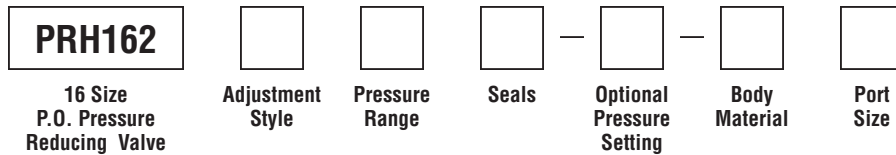

Code	Adjustment Style / Kit No.
F	Fixed style, preset at factory.
K	Knob Adjust (717784-15)
S	Screw Adjust
T	Tamper Resistant Cap (717785)

Code	Seals / Kit No.
Omit	Nitrile / (SK16-3)
V	Fluorocarbon / (SK16-3V)

Code	Body Material
Omit	Steel
A	Aluminum

Code	Pressure Range
10	6.9 - 69 Bar (100 - 1000 PSI) Standard Setting: 34.5 Bar (500 PSI)
20	13.8 - 138 Bar (200 - 2000 PSI) Standard Setting: 69 Bar (1000 PSI)
30	20.7 - 207 Bar (300 - 3000 PSI) Standard Setting: 103.5 Bar (1500 PSI)
50	34.5 - 345 Bar (500 - 5000 PSI) Standard Setting: 172.4 Bar (2500 PSI)

Optional Pressure Setting
Pressure ÷ 10 i.e. 235 = 2350 PSI (Omit if standard setting is used) Setting Range: 100 to 5000 PSI

Code	Port Size	Body Part No.
Omit	Cartridge Only	
12T	SAE-12	(B16-3-*12T)
16T	SAE-16	(B16-3-*16T)

* Add "A" for aluminum, omit for steel.

- CV**
Check Valves
- SH**
Shuttle Valves
- LM**
Load/Motor Controls
- FC**
Flow Controls
- PC**
Pressure Controls
- LE**
Logic Elements
- DC**
Directional Controls
- MV**
Manual Valves
- SV**
Solenoid Valves
- PV**
Proportional Valves
- CE**
Coils & Electronics
- BC**
Bodies & Cavities
- TD**
Technical Data