

Technical Information

- CV** Check Valves
- SH** Shuttle Valves
- LM** Load/Motor Controls
- FC** Flow Controls
- PC** Pressure Controls
- LE** Logic Elements
- DC** Directional Controls
- MV** Manual Valves
- SV** Solenoid Valves
- PV** Proportional Valves
- CE** Coils & Electronics
- BC** Bodies & Cavities
- TD** Technical Data

General Description

Direct Acting Relief Valve. This valve is designed for pilot flow circuits. For additional information see Technical Tips on pages PC1-PC6.



Features

- Hardened, precision ground parts for durability
- Low profile adapter for minimal space requirements
- Fully guided pilot for more consistent reseal
- Steel adapters are zinc plated
- Polyurethane "D"-Ring eliminates backup rings and prevents hydrolysis

Specifications

Rated Flow	1.9 LPM (.5 GPM)								
Maximum Inlet Pressure	380 Bar (5500 PSI)								
Maximum Pressure Setting	350 Bar (5000 PSI)								
Sensitivity: Pressure/Turn	<table style="display: inline-table; border: none;"> <tr> <td style="padding-right: 10px;">10</td> <td>19.6 Bar (285 PSI)</td> </tr> <tr> <td>20</td> <td>39.3 Bar (570 PSI)</td> </tr> <tr> <td>30</td> <td>58.9 Bar (859 PSI)</td> </tr> <tr> <td>50</td> <td>131.7 Bar (1910 PSI)</td> </tr> </table>	10	19.6 Bar (285 PSI)	20	39.3 Bar (570 PSI)	30	58.9 Bar (859 PSI)	50	131.7 Bar (1910 PSI)
10	19.6 Bar (285 PSI)								
20	39.3 Bar (570 PSI)								
30	58.9 Bar (859 PSI)								
50	131.7 Bar (1910 PSI)								
Reseat Pressure	90% of crack pressure								
Leakage at 150 SSU (32 cSt)	5 drops/min. (.33 cc/min.) @75% of crack pressure								
Cartridge Material	All parts steel. All operating parts hardened steel.								
Operating Temp. Range/Seals	-45°C to +132°C ("D"-Ring) (-50°F to +270°F) -34°C to +121°C (Nitrile) (-30°F to +250°F) -26°C to +204°C (Fluorocarbon) (-15°F to +400°F)								
Fluid Compatibility/Viscosity	Mineral-based or synthetic with lubricating properties at viscosities of 45 to 2000 SSU (6 to 420 cSt)								
Filtration	ISO-4406 18/16/13, SAE Class								
Approx. Weight	.09 kg (.20 lbs.)								
Cavity	C08-2 (See BC Section for more details)								
Form Tool	<table style="display: inline-table; border: none;"> <tr> <td>Rougher</td> <td>None</td> </tr> <tr> <td>Finisher</td> <td>NFT08-2F</td> </tr> </table>	Rougher	None	Finisher	NFT08-2F				
Rougher	None								
Finisher	NFT08-2F								

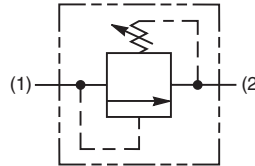
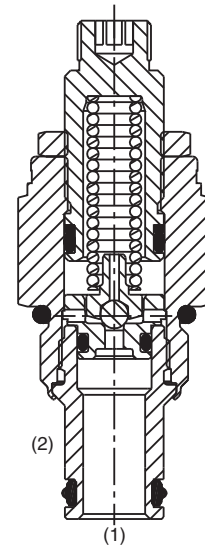
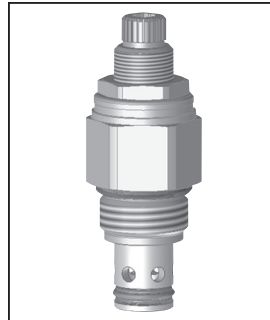

Performance Curve
Flow vs. Inlet Pressure

(Pressure rise through cartridge only)

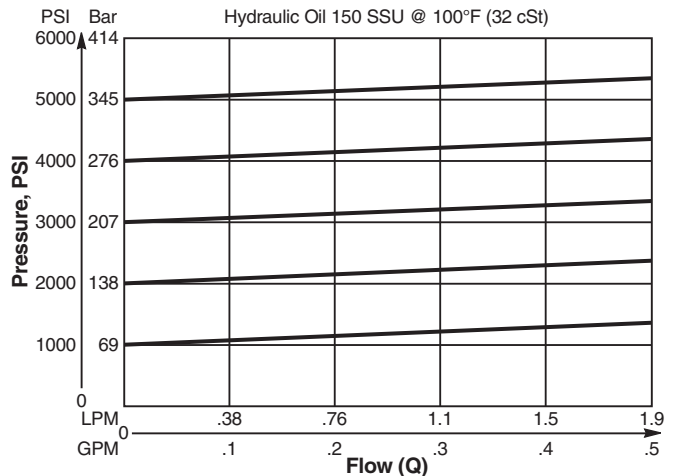

Dimensions Millimeters (Inches)

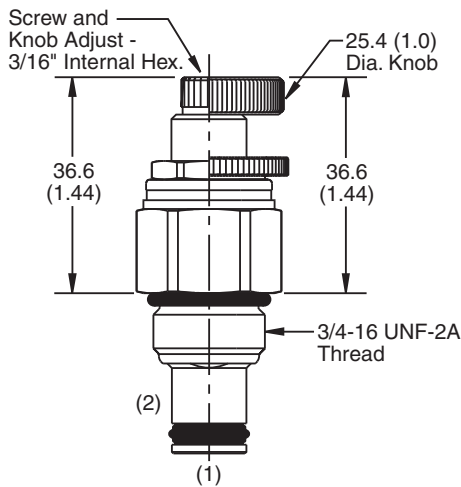

Screw/Knob Version

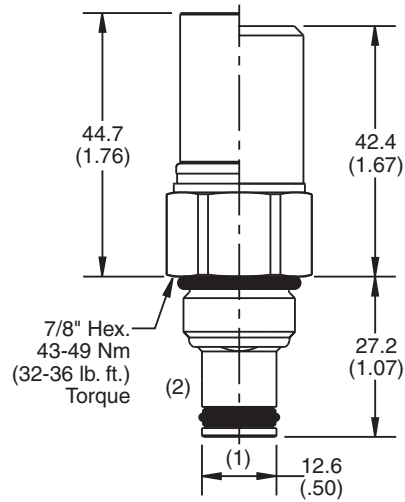

Fixed Cap/Tamper Resistant Version

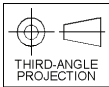

Ordering Information

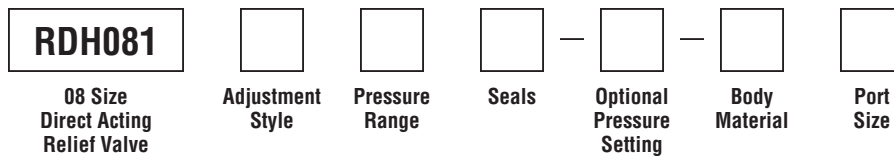

Code	Adjustment Style / Kit No.
F	Fixed style, preset at factory.
K	Knob Adjust (717784-10)
S	Screw Adjust
T	Tamper Resistant Cap (717943)

Code	Seals / Kit No.
Omit	"D"-Ring / (SK08-2)
N	Nitrile / (SK08-2N)
V	Fluorocarbon / (SK08-2V)

Code	Body Material
Omit	Steel
A	Aluminum

Code	Pressure Range
10	6.9 - 69 Bar (100 - 1000 PSI) Standard Setting: 34.5 Bar (500 PSI) @ crack pressure, approximately 100 cc/min (6.1 in³/min)
20	6.9 - 138 Bar (100 - 2000 PSI) Standard Setting: 69 Bar (1000 PSI) @ crack pressure, approximately 100 cc/min (6.1 in ³ /min)
30	13.8 - 207 Bar (200 - 3000 PSI) Standard Setting: 103.5 Bar (1500 PSI) @ crack pressure, approximately 100 cc/min (6.1 in³/min)
50	13.8 - 345 Bar (200 - 5000 PSI) Standard Setting: 172.4 Bar (2500 PSI) @ crack pressure, approximately 100 cc/min (6.1 in³/min)

Optional Pressure Setting	
Pressure ÷ 10	i.e. 235 = 2350 PSI
(Omit if standard setting is used)	
Setting Range:	100 to 5000 PSI
All settings at crack pressure, approximately 100 cc/min (6.1 in ³ /min)	

Code	Port Size	Body Part No.
Omit	Cartridge Only	
4T	SAE-4	(B08-2-*4T)
6T	SAE-6	(B08-2-*6T)

* Add "A" for aluminum, omit for steel.

- CV**
Check Valves
- SH**
Shuttle Valves
- LM**
Load/Motor Controls
- FC**
Flow Controls
- PC**
Pressure Controls
- LE**
Logic Elements
- DC**
Directional Controls
- MV**
Manual Valves
- SV**
Solenoid Valves
- PV**
Proportional Valves
- CE**
Coils & Electronics
- BC**
Bodies & Cavities
- TD**
Technical Data