

- CV**
Check Valves
- SH**
Shuttle Valves
- LM**
Load/Motor Controls
- FC**
Flow Controls
- PC**
Pressure Controls
- LE**
Logic Elements
- DC**
Directional Controls
- MV**
Manual Valves
- SV**
Solenoid Valves
- PV**
Proportional Valves
- CE**
Coils & Electronics
- CB**
Cartridge Bodies
- BC**
Bodies & Cavities
- TD**
Technical Data

General Description

Pilot Operated Pressure Reducing Valve. For additional information see Technical Tips on pages PC1-PC6.



Features

- Hardened, precision ground parts for durability
- Low profile adapter for minimal space requirements
- Fully guided pilot for more consistent reseal
- Steel adapters are zinc plated
- Polyurethane “D”-Ring eliminates backup rings and prevents hydrolysis
- Internal screening protects pilot spring from debris

Specifications

Rated Flow	30 LPM (8 GPM)
Maximum Inlet Pressure	380 Bar (5500 PSI)
Maximum Pressure Setting	350 Bar (5000 PSI)
Sensitivity: Pressure/Turn	10 25 Bar (362 PSI) 30 64.2 Bar (932 PSI) 50 137 Bar (1987 PSI)
Maximum Tank Pressure	350 Bar (5000 PSI)
Maximum Drain Flow	0.56 LPM (0.15 GPM)
Cartridge Material	All parts steel. All operating parts hardened steel.
Operating Temp. Range/Seals	-37°C to +93°C (“D”-Ring) -35°F to +200°F -34°C to +121°C (Nitrile) (-30°F to +250°F) -26°C to +204°C (Fluorocarbon) (-15°F to +400°F)
Fluid Compatibility/Viscosity	Mineral-based or synthetic with lubricating properties at viscosities of 45 to 2000 SSU (6 to 420 cSt)
Filtration	ISO-4406 18/16/13, SAE Class 4
Approx. Weight	0.11 kg (0.25 lbs.)
Cavity	C08-3 (See BC Section for more details)
Form Tool	Rougher NFT08-3R Finisher NFT08-3F

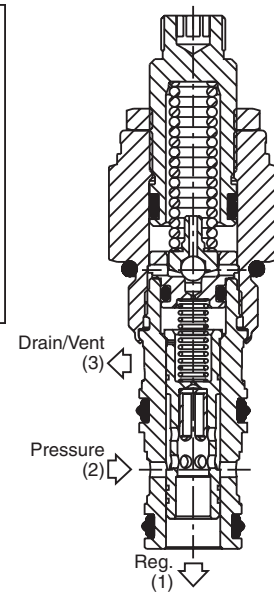
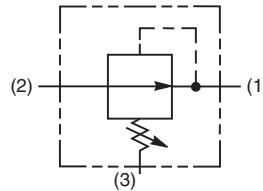
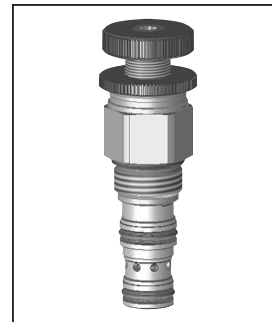

Performance Curves

Flow vs. Pressure (Through cartridge only)

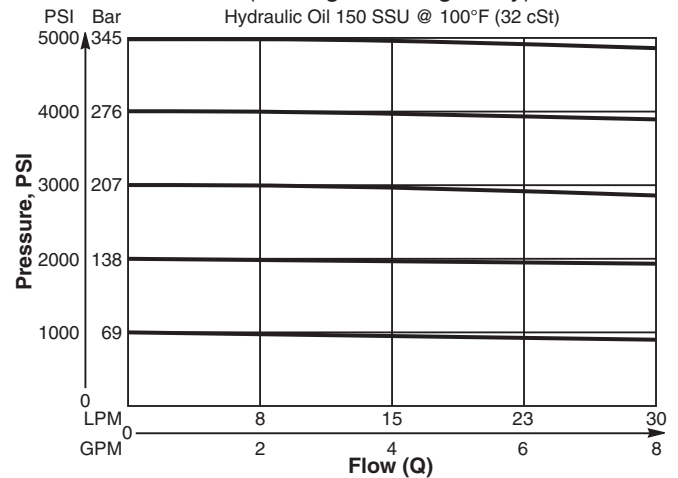

Flow vs. Pressure Drop (Through cartridge only)

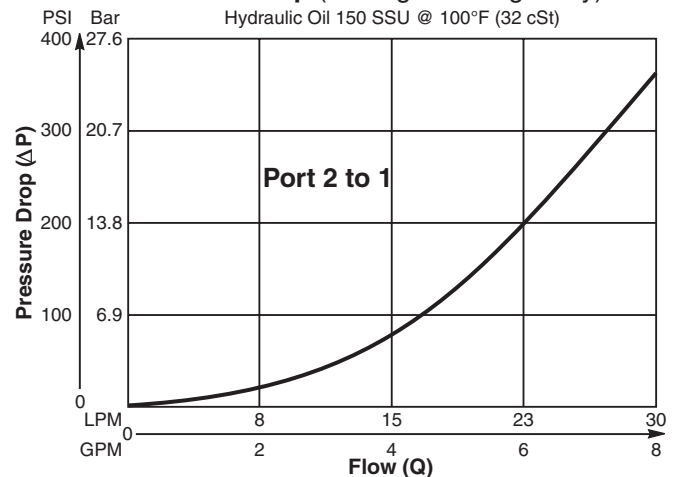

Dimensions Millimeters (Inches)

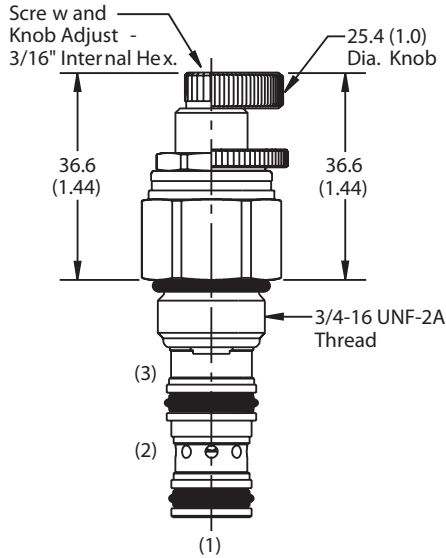

Screw/Knob Version

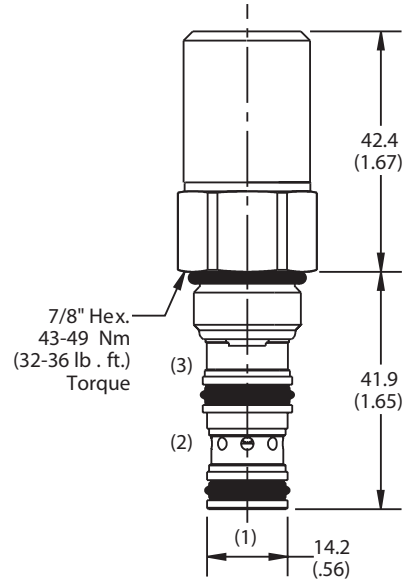

Tamper Resistant Version

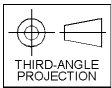

Ordering Information

PRH082			
08 Size P.O. Pressure Reducing Valve	Adjustment Style	Pressure Range	Seals

Highlighted represents preferred options that offer the shortest lead times. Other options may be available, but at extended lead times.

Code	Adjustment Style / Kit No.
K	Knob Adjust (717784-10)
S	Screw Adjust
T	Tamper Resistant Cap (717943)

Code	Seals / Kit No.
Omit	"D"-Ring / (SK08-3)
N	Nitrile / (SK08-3)
V	Fluorocarbon / (SK08-3V)

Code	Pressure Range
10	6.9 - 69 Bar (100 - 1000 PSI) Standard Setting: 34.5 Bar (500 PSI)
30	13.8 - 207 Bar (200 - 3000 PSI) Standard Setting: 103.5 Bar (1500 PSI)
50	13.8 - 345 Bar (200 - 5000 PSI) Standard Setting: 172.4 Bar (2500 PSI)

NOTE: For settings below 20.7 Bar (300 PSI), flow rating is limited to 11.3 LPM (3 GPM).

Order Bodies Separately
 See section BC

B08	-	3	-	
08 size		3-Way Cavity		Port Size

Code	Porting / Body Material
6T	SAE-6 / Steel (5000 PSI)
A6T	SAE-6 / Aluminium (3000 PSI)

CV
Check Valves
SH
Shuttle Valves
LM
Load/Motor Controls
FC
Flow Controls
PC
Pressure Controls
LE
Logic Elements
DC
Directional Controls
MV
Manual Valves
SV
Solenoid Valves
PV
Proportional Valves
CE
Coils & Electronics
CB
Cartrpак Bodies
BC
Bodies & Cavities
TD
Technical Data