



Launching Innovation

Systems strength. Component solutions.



ENGINEERING YOUR SUCCESS.



COMMERCIAL



MILITARY



ENGINES



BUSINESS AND
GENERAL AVIATION



HELICOPTERS

Photo courtesy U.S. Army



WORLDWIDE CUSTOMER SUPPORT

Advancing the global aerospace fleet to fly higher, faster, longer, and more efficiently.

The world's leading aircraft manufacturers choose Parker Aerospace as a technology partner, relying on our mastery of flight control, hydraulic, fuel, inerting, fluid conveyance, thermal management, pneumatic, and lubrication systems and components.

As an operating group of Parker Hannifin Corporation, the world leader in motion and control technologies, Parker Aerospace has the engineering muscle and stable foundation to truly move our customers' programs forward while increasing their productivity and profitability.

Parker Hannifin by the numbers

1,100+ industrial and aerospace markets

Nearly
1 million products offered

50,000+ employees

3,000+ product lines

13,000+ distribution/MRO locations

1 of the **FORTUNE 300**

0 competitors with a bigger product line

Parker Aerospace technology solutions



Flight control actuation



Fuel



Inerting



Hydraulics



Fluid conveyance



Pneumatics



Lubrication



Thermal management

COMMERCIAL AIRCRAFT

Systems and components that provide greater reliability, efficiency, and value



Parker equipment supports nearly every commercial aircraft flying, sending them safely and efficiently throughout the world. We work alongside aircraft manufacturers to design in performance, using lighter materials and smart, self-monitoring products.

Unmatched engineering expertise couples with manufacturing excellence to offer systems and components that meet the demands of an increasing digital industry, while providing ultimate dependability over program life.

The breadth of our organization allows us to focus on such functions as quality, program management, lean practices, and supply chain strategies, to ensure the optimum customer experience.

Parker's global customer support team of aftermarket field engineers makes it a priority that our customers' aircraft are logging miles, not hangar time. ■



System and component program pedigree

Airbus A220, A320, A330, A340, A350, A380 | Boeing 737, 747, 767, 777, 787 | Bombardier CRJ Series, Q Series | COMAC ARJ21, C919 | Embraer Embraer ERJs, E-jets, E-jets E2 | Xian MA700



Airbus A220



Airbus A350



Boeing 737 MAX



Boeing 787



COMAC C919



Embraer E170/175/190/195

Joint ventures in China support COMAC programs and regional aftermarket



NEIAS Parker Aero Systems & Equipment
6,800-square-meter facility in Nanjing.



Parker FACRI Actuation Systems
7,400-square-meter facility in Xi'an.

NEIAS Parker Aero Systems & Equipment

is an AS9100- and NADCAP-approved joint venture between Parker Aerospace and AVIC Jincheng Nanjing Engineering Institute of Aircraft Systems (NEIAS) in Nanjing, China. It provides advanced manufacturing and special processing for fuel and hydraulic systems and components for the C919 and future Chinese aircraft.

Parker FACRI Actuation Systems

is an AS9100- and NADCAP-approved joint venture between Parker Aerospace and AVIC Flight Automatic Control Research Institute (FACRI) in Xi'an, China. It performs OEM production and support for flight control actuators for the ARJ21, C919,

and MA700. The facility also has a world-class FAA 145/CAAC 145-approved maintenance, repair, and overhaul operation to support Parker Aerospace equipment for the Chinese airline fleet, as well as that produced by other manufacturers. It includes an inventory pooling center and a fluid conveyance distribution hub. ■

Systems integration: integral to system performance

Across aircraft system types – flight control, fuel, inerting, hydraulic, fluid conveyance – Parker's deep and broad component offering coalesces with two decades of system design knowledge in the area of system integration. Throughout our organization we have developed our own custom test rigs and system simulation laboratories that enable us to predict and optimize system performance. These rigs, representing hundreds of millions of dollars in investment, enable Parker to assume the integration responsibility on behalf of our customer, simulating all possible flight conditions to test every element of a system. ■



Eight complete airframe flight control SILs perform cockpit-to-control surface functions.



All operational conditions are tested, including extreme heat, cold, load, and inertia.



The cockpit and flight control computer are simulated in the flight control systems testing process.



Software is tested and qualified before being integrated with hardware for integration testing.

Commercial aircraft component technologies



Aircraft engine-driven pumps



Highly resistive unions



PGW/EGW cooling systems



Dual-flow motor-driven pumps



Horizontal stabilizer trim actuators



Electrohydraulic servovalves

MILITARY AIRCRAFT

Following the military order for performance and affordability



With a pedigree that began in the 1930s to the most advanced manned and unmanned platforms of today, Parker is a well-established partner with military aviation, realizing that the highest performance standards must be achieved while maintaining a firm grip on costs.

Understanding the unique needs of the warfighter, Parker Aerospace works closely with military aircraft customers to learn program requirements and deliver solutions that meet the needs of our armed services.

Systems and component experience enables Parker to employ a big-picture strategy in the programs it supports. We can turn to our extensive off-the-shelf technology solutions to reduce design cost and boost reliability, while enhancing performance through the application of our composite material, electronics packaging, and more-electric expertise. ■



System and component program pedigree

Airbus A400M | Bell Boeing V-22 | Boeing AH-64, C-17, CH-47, F-15, F/A-18 E/F, KC-46A, P-8A, X-45 | General Atomics Aeronautical Systems Predator B | Korea Aerospace Industries K-FX, T-50 | Lockheed Martin C-130, F-16, F-22, F-35, JASSM, RATTLS | Northrop Grumman BAMS, Global Hawk, X-47A | Raytheon Griffin, Javelin, JSM, Tomahawk | Saab Gripen | Sikorsky CH-53, MH-60/UH-60



Airbus A400M



Bell Boeing V-22 Osprey



Boeing C-17



General Atomics Aeronautical Systems Predator B



Lockheed Martin F-35



Lockheed Martin Sikorsky UH-60 BLACK HAWK® helicopter

BLACK HAWK® is a registered trademark of Sikorsky Aircraft Corporation.



KC-46A

KC-46A: mission-safe with Parker technology

Designed to refuel U.S., allied, and coalition military aircraft, the KC-46A Pegasus relies on a broad array of Parker Aerospace equipment to keep it mission-safe.

Parker's primary flight control actuation products, including rudder, elevator, aileron, flap, and stabilizer, help keep the tanker on target, while our robust fuel and hydraulic components provide the power needed for its long hauls.

The Pratt & Whitney PW4000 engines on the KC-46A are supported by scores of Parker products, including pneumatics, fluid conveyance, pumps, and thrust reverser actuators.

The Pegasus will enable our military fleets to complete their missions. And Parker products will make sure that the Pegasus is ready to do so. ■

Parker EHAs: a first for fighters

Lockheed Martin's F-35 is the first production fighter with a system of electrohydraulic actuators (EHAs) powering all primary flight control surfaces. EHAs save system weight, offer enhanced avionics integration, and reduce lifecycle costs. ■



F-35 horizontal tail electrohydraulic actuator

Military aircraft component technologies



Hydraulic power supply units



Quick-disconnect couplings



Aircraft nosewheels and mainwheels



Electromechanical missile control actuation systems



Fly-by-wire flight control actuators



Aerial refueling receptacles



As a PI&R effort for aircraft flying our fuel tank inerting and aircraft fire suppression systems, Parker Aerospace is introducing an even more reliable dewars nitrogen storage solution for the C-5. The enhanced equipment will lower operational disruptions for customers, helping reduce costs and increase aircraft mission availability.

PI&R: enhancing performance to reduce military life-cycle costs

Parker's dedicated Customer Support military operation backs our defense customers with product improvements & retrofits (PI&R). By cost-effectively integrating advanced new technology into our fielded products, we're helping to enhance the performance and extend the life of military fleets. Defense programs benefitting from PI&R include the B-2, C-5, C-130, F-15, F-16, KC-135, UH-60, and CFM56 engine. ■

BUSINESS & GENERAL AVIATION AIRCRAFT

Increasing productivity efficiently, flexibly,
and cost-effectively



Business aviation allows passengers to reach destinations quickly while using time efficiently. Parker

Aerospace has been a key supplier to the business, general aviation, and commercial helicopter market since the 1930s. Our support has ranged from single components, such as general aviation master cylinders, to fully integrated fuel, hydraulic, and flight control systems for the highest-performing business jets.

Today we continue to meet the needs of our customers, working collaboratively to offer innovative new ideas to boost performance coupled with our deep selection of off-the-shelf technologies that help manage cost. ■

System and component program pedigree

Airbus Helicopters H130, H145, H160, H225, NH90 | **Beechcraft** Baron, Bonanza, King Air | **Bell** 206, 407, 412, 429, 505, 525, Huey II | **Bombardier** Challenger 350/650, Global Express, Global 5000/6000/7000/8000, Learjet 70/75 | **Cessna** Caravan, Citation, Denali, Skyhawk, Skylane | **Cirrus** SR20, R22, Vision Jet | **Eclipse** 550 | **Embraer** Legacy 450/500/650E, Phenom 100/200 | **Gulfstream** G280, G450, G500, G550, G600, G650, G650ER | **Leonardo** AW109, AW119, AW139, AW169, AW609 | **Pilatus** PC-12, PC-24 | **Piper** M-Class, Trainer Class, Twin Class | **Sikorsky** S-76®, S-92®



Beechcraft King Air



Bell 407



Bombardier Global 7000



Cessna Citation X



Embraer Legacy



Sikorsky S-76® helicopter

S-76® and S-92® are registered trademarks of Sikorsky Aircraft Corporation.

Cleveland Wheels & Brakes: over 80 years of safe takeoffs and landings

With hundreds of FAA TSO qualifications on single- and twin-engine fixed-wing, light jet, and rotorblade aircraft, Parker's Cleveland Wheels & Brakes can be found on over 80 percent of the general aviation fleet. The brand is synonymous with better braking, smoother and more reliable landings, convenient worldwide availability, and valuable savings on maintenance, downtime, and labor. ■



Piper Meridian



Over 80 percent of the general aviation fleet depends on Cleveland Wheels & Brakes

Taking care of business on the G650

Parker Aerospace supports Gulfstream's G650 business jet with a broad portfolio of systems and components, starting with the aircraft's fully digital three-axis fly-by-wire primary flight control system and electric backup hydraulic actuators. Hydraulic equipment includes pumps, nose-gear door and retraction actuators, maingear door actuation, entry door actuation, reservoirs, valves, and hoses.

In addition, we supply airframe equipment for fuel quantity indication, lubrication, and fluid conveyance as well as the waste drain valve, ecology bottle, and flame arrestors. The G650's Rolls-Royce BR725 engines are outfitted with Parker's fuel atomization nozzles, hoses, quick disconnects, and lubrication equipment. ■



Business jet and general aviation component technologies



Electric motor-driven pumps



Breakaway safety valves



Multi-rotor steel brake assemblies



Remote oil replenishment units



Mechanical input actuators



Remote electronic units

ENGINE MARKET

Higher-powered, lower-emission solutions



Engine makers face ongoing challenges in the areas of noise, fuel burn, and emissions.

With Parker Aerospace, aero engine manufacturers have an experienced partner that can help them meet regulatory requirements while delivering the performance and low cost of ownership that their customers demand.

Our expertise touches every corner of the aviation engine market: commercial, regional, business, military, and rotor. We provide advanced systems and component solutions for fuel atomization, fuel

manifolds, engine pneumatics, lubrication, engine build-up, heat management, control electronics and more.

Looking ahead, we partner with engine customers to share risk and develop new technologies, which in turn helps them to help their civilian and military customers achieve important program objectives. ■

System and component program pedigree

CFM International CFM56, LEAP | **EuroProp International** TP400-D6 | **GE** CF6, CF34, F101, F110, F404/F414, GEnx, GE9x, GE90, Passport 20, T700 | **International Aero Engines** V2500 | **Pratt & Whitney** F119, F135, PW1000, PW2000, PW4000, | **Rolls-Royce** AE 2100, AE 3007, BR700, Trent 1000, Trent 7000, Trent XWB



CFM International LEAP



General Electric T700



General Electric GEnx



Pratt & Whitney 1000G



Pratt & Whitney F135



Rolls-Royce Trent 7000



Rolls-Royce Trent XWB



Rolls-Royce BR725

Advanced Atomization Technologies: fueling performance and growth

Fuel atomization nozzle know-how is a key contributor to reducing fuel burn, boosting efficiency, and cutting emissions. Established to support innovative fuel nozzle development and production, Advanced Atomization Technologies (AATECH) is a joint venture between GE Aviation and Parker Aerospace. AATECH designs and produces fuel nozzles for some of the most powerful and efficient gas turbines built by GE Aviation, including the CFM LEAP, GE9X, and GENx engines. Current and legacy engine programs – such as the GE90, CF6, and CFM56 – are also supported at AATECH. ■



AATECH facility in Clyde, New York.

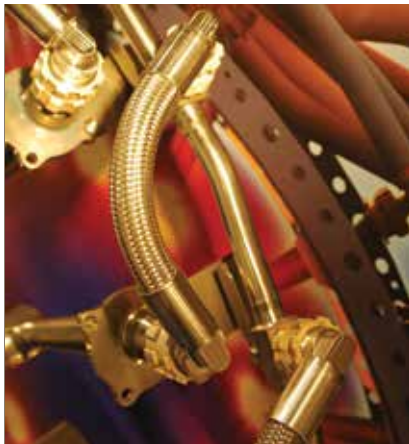

Flexible fuel lines: saving weight, managing vibration

Aircraft engine fuel manifolds are often designed as a system of rigid tubing and fittings that surround the engine's combustion section. Parker Aerospace is taking steps to reduce the weight of fuel manifolds by replacing rigid tubing with flexible high-temperature fuel lines. The flexible manifolds manage vibratory loads more efficiently, and can save weight by requiring fewer brackets. ■

Additive manufacturing: increasing value, subtracting development time and cost

Additive manufacturing is proving to be key to creating prototypes for test during the product development process, as well as for finished, in-service applications. A dedicated corporate innovation center helps direct and unify this quickly evolving process.

Parker is combining the unique advantages of additive technologies with its traditional manufacturing prowess to offer its customers the best and most reliable component solutions at a reasonable cost. ■



Engine component technologies



Fuel metering units



High-temperature flexible hoses



Main engine lubrication and scavenge pumps



Oil reservoirs



Fuel atomization nozzles



Engine stator section anti-ice valves

FLIGHT CONTROL ACTUATION SYSTEMS AND COMPONENTS



Parker Aerospace is the number-one stick-to-surface flight control system

provider in the world, and a global leader in fly-by-wire flight controls. Our systems pedigree is over three decades long and our overall experience nearly a century deep in both military and civilian applications.

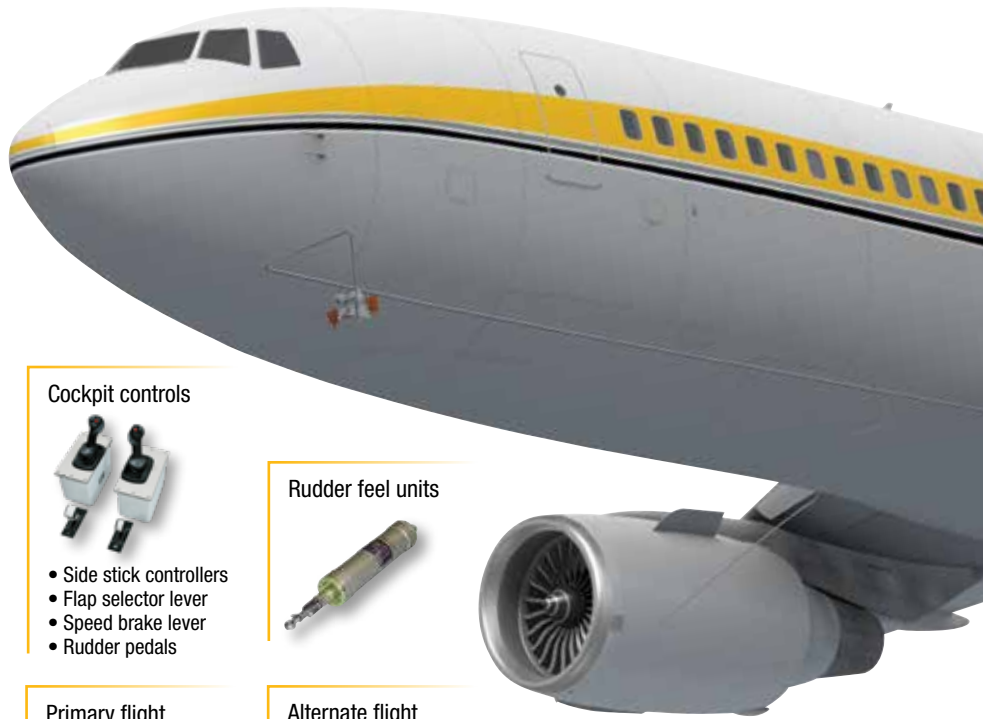

Cockpit controls



- Side stick controllers
- Flap selector lever
- Speed brake lever
- Rudder pedals

Rudder feel units



Primary flight control computers



Alternate flight control units



Stick-to-surface fly-by-wire flight control systems

- Airbus A220
- Embraer Legacy 450 and 500
- Bombardier Global 7000 and 8000



Lockheed Martin F-22

Electrohydraulic flight controls: tested, proven, trusted.

Our fly-by-wire primary and secondary flight controls have been in civil and military applications for decades, providing unparalleled performance and reliability.



EHA and EBHA innovation

The product of two-plus decades of research, development, and flight-tested reliability, Parker electrostatic actuators (EHAs) and electrical backup hydraulic actuators (EBHAs) lower system weight, decrease power consumption, and reduce lifecycle costs.

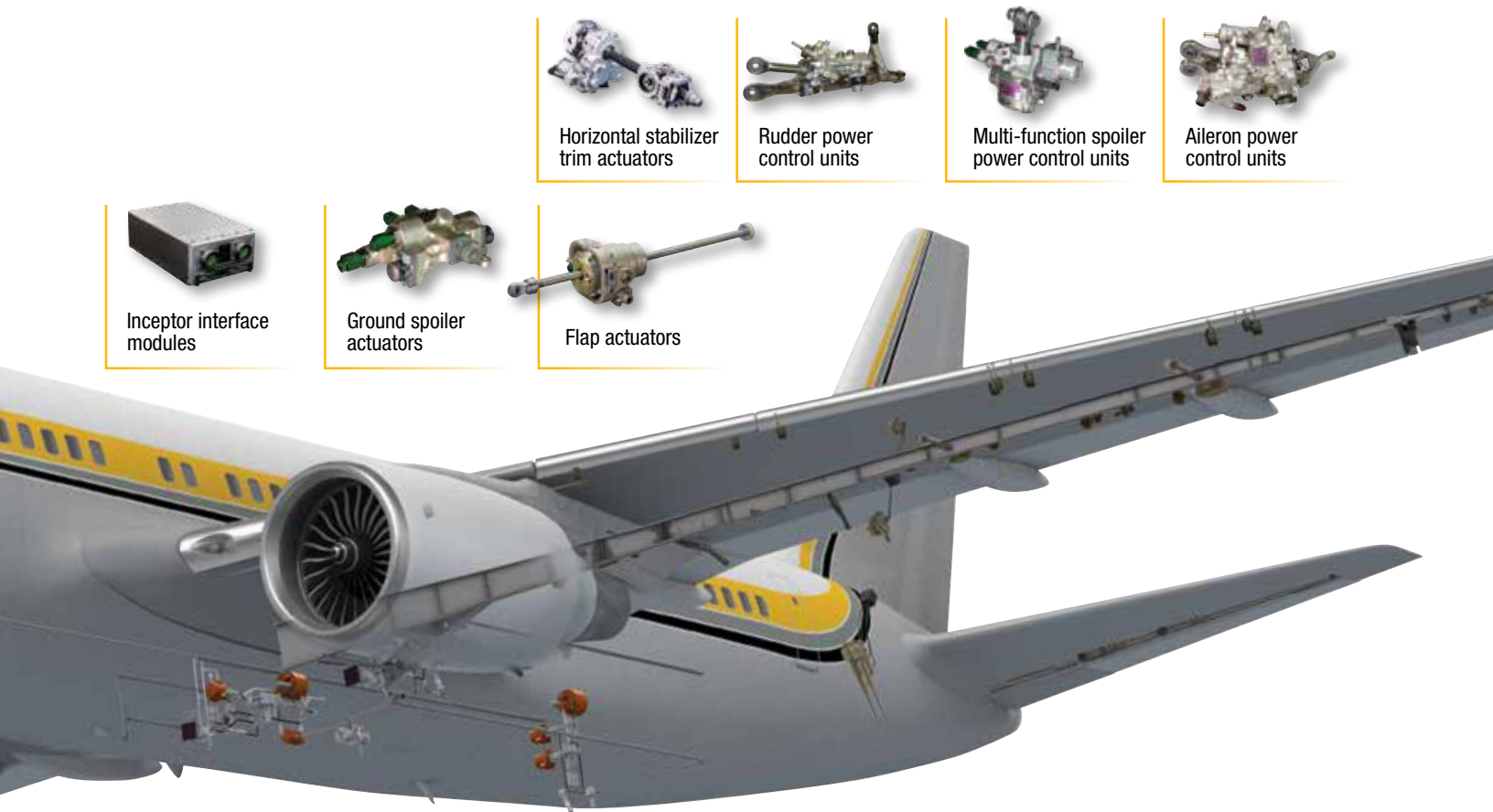

Horizontal stabilizer trim actuators



Rudder power control units



Multi-function spoiler power control units



Aileron power control units



Inceptor interface modules



Ground spoiler actuators



Flap actuators

Remote electronics units



Ground spoiler control modules



Flap power drive units



Motor control electronics



Elevator power control units



Embraer Phenom

More-electric EMAs

Parker's adaptable and scalable electromechanical actuation (EMA) equipment, such as that for Embraer's Phenom, offer the benefit of more affordable systems that require less lead time. We also provide EMA systems for the Raytheon/ Lockheed Martin Javelin missile, Lockheed Martin Polecat, and many other military and civilian platforms.

SILs: helping to get to market faster

Parker's flight control systems integration laboratories (SILs) allow us to bring subsystems and full stick-to-surface systems to market faster and more cost effectively. SILs allow for complete development and integration, and aid in the certification of modular, fly-by-wire flight control systems.



FUEL SYSTEMS AND COMPONENTS



As the premier global provider of fuel systems and components, Parker Aerospace offers a broad and deep portfolio of solutions for virtually every type of aircraft in the sky. Our customers look to us to provide design, integration, manufacture, certification, and lifetime support of their aircraft, improving their program and business performance.

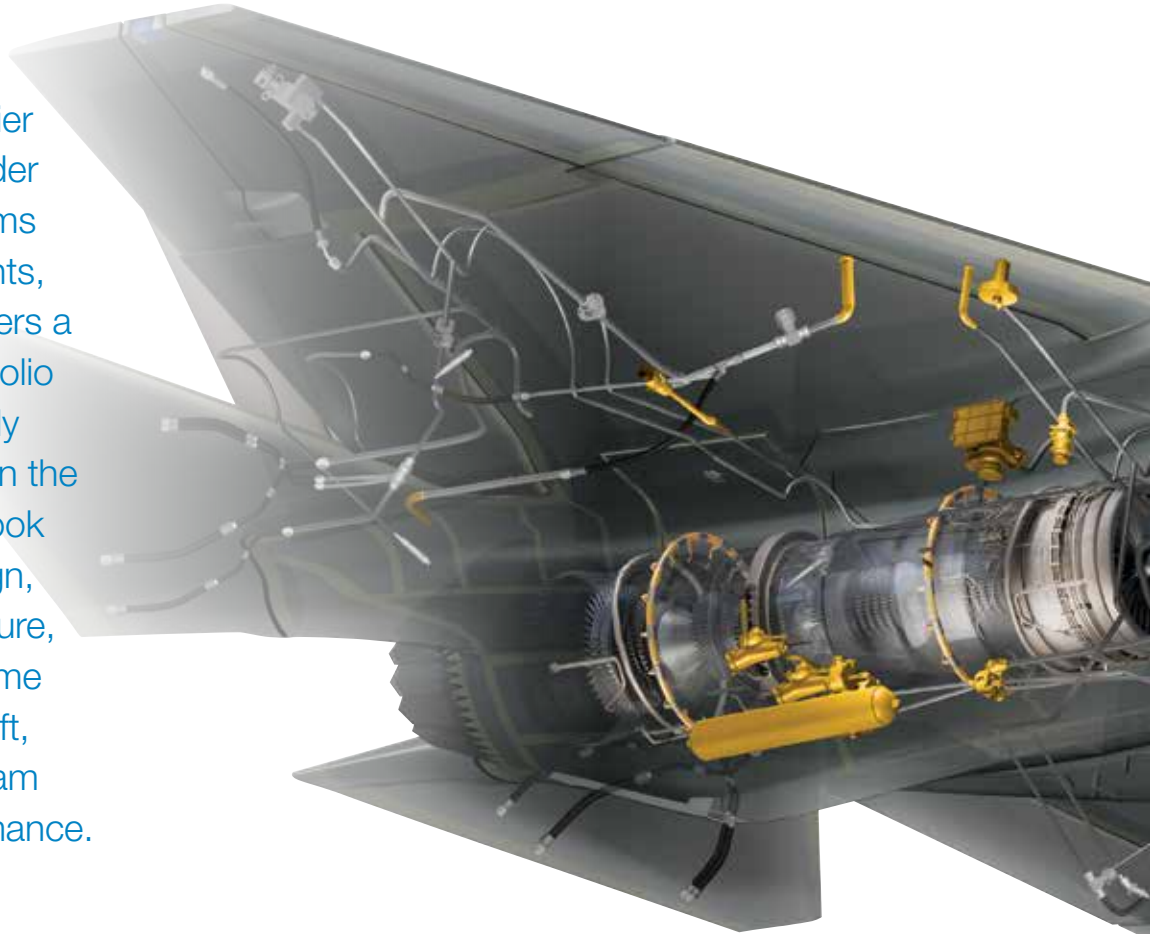

270 V BLDC fuel boost pumps

Motor-driven pumps drive efficiency

Our pumps can be designed to work with all types of power. The pump shown is unique, powered by 270 V BLDC. The overarching advantage of our fuel pump product line is its compatibility with constant or variable frequency AC, and DC power.



Measurable high performers: fuel gauging equipment

Parker's fuel measurement and management systems and components are engineered to reduce weight and save fuel while minimizing costs and maximizing efficiency.



Smart fuel metering motor-driven pumps



Fuel boost pumps



Motor-operated fuel shutoff valves



Ejector pumps



Lightning Safe® caps and adapters



Wing tank pumps



Fuel transfer pumps



Fuel scavenge valves



Engine feed shutoff valves



Fueling excellence: on-site system testing

Extensive on-site capabilities and a state-of-the-art fuel system testing laboratory duplicate actual operating conditions, giving Parker Aerospace the proven capacity to test complete aircraft fuel systems and components.

Aerial refueling: making the right connection

Military customers have long looked to Parker Aerospace to provide the critical equipment needed for extending the range of their aircraft. Our refueling couplers, nozzles, receptacles, and test kits represent today's leading edge in aerial refueling design, performance, and durability.



Photo courtesy of U.S. Air Force

INERTING SUBSYSTEMS



With more than 50 years of experience in the complex science of fuel tank fire suppression, Parker is the world leader in inerting systems used in both military and commercial markets. Our commercial fuel tank inerting equipment is used by more than 85% of the transport aircraft in production today, on 15 major platforms.



Catalytic inerting: the next-generation solution

Catalytic inerting technology enables simpler and lighter-weight fuel tank inerting systems. Requiring no bleed air or attachment to the aircraft pneumatic system, catalytic inerting can be a significant advantage for aircraft with little or no available bleed air, such as those powered by turboshaft, turboprop, or small turbofan engines.

In the interest of serving the customer through product development and via an exclusive license between Parker Aerospace and PHYRE Technologies,

both organizations are collaborating to bring catalytic inerting to the marketplace.

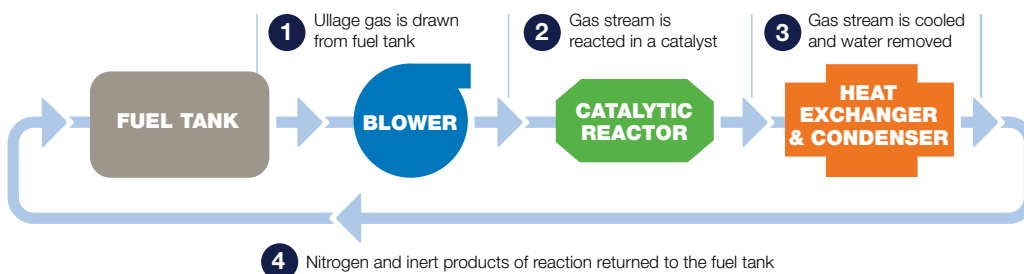

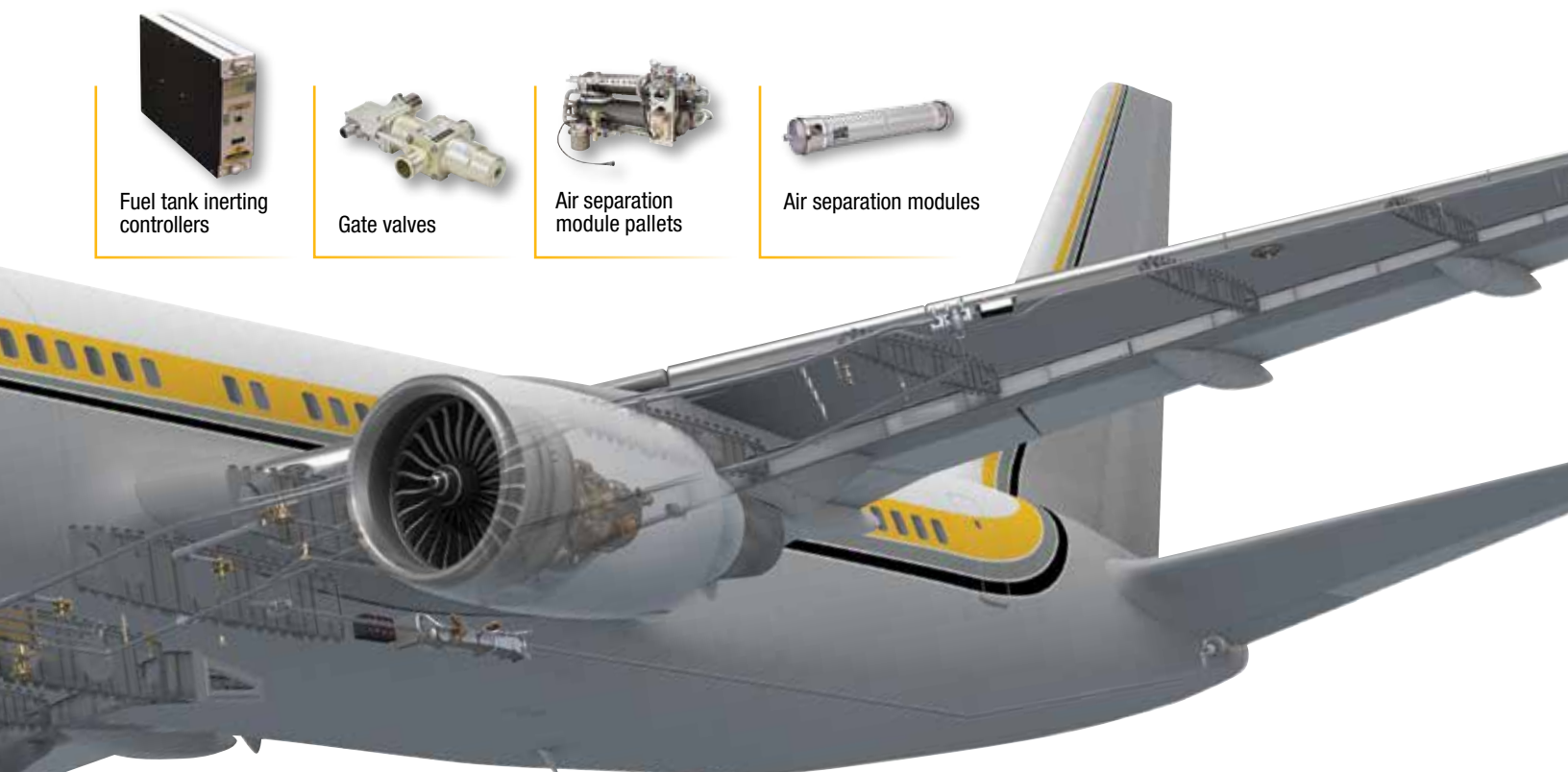

Fuel tank inerting controllers

Gate valves

Air separation module pallets

Air separation modules

Dual-flow shutoff valves

Inlet isolation valves

Single air separation module pallets

A brief summary of a long inerting history

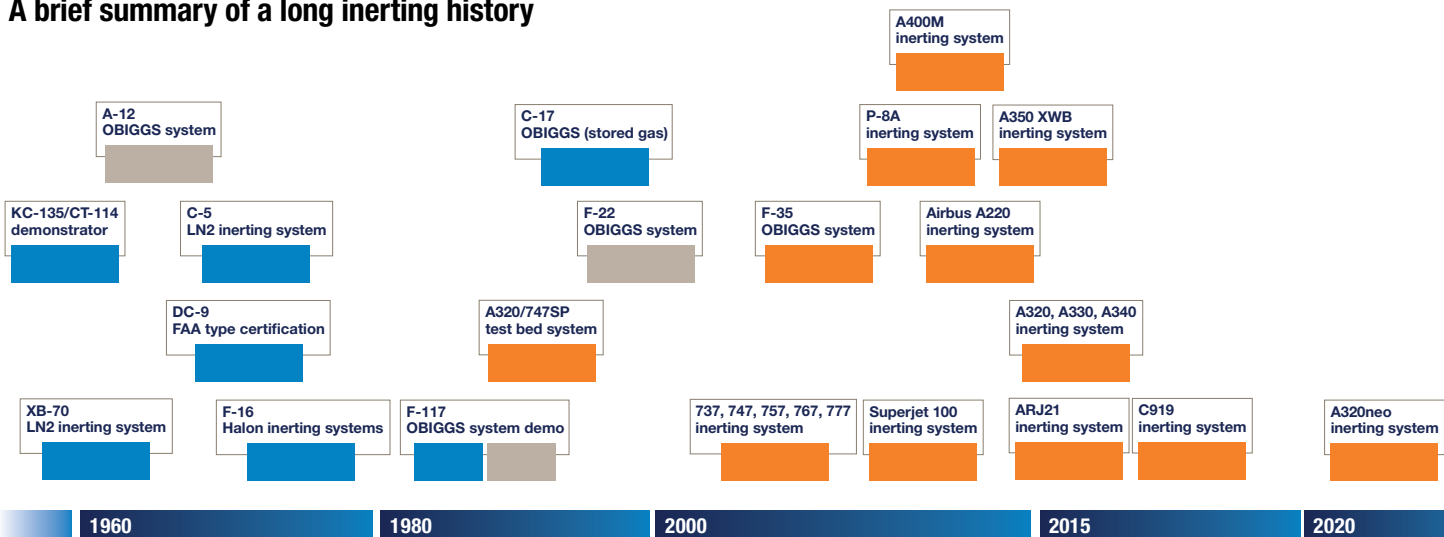

Migration from stored gas to permeable membranes

HYDRAULIC SYSTEMS AND COMPONENTS



As the leading provider of fully integrated

hydraulic systems and advanced hydromechanical and electromechanical subsystems and components, Parker Aerospace offers the talent and resources our customers count on for program success. Our range of system functions includes hydraulic rotating products, hydraulic utility products, and actuation systems.



Thrust reverser actuators



Filtration: adding life to hydraulic systems

Partnering with Parker's Filtration Group, Parker Aerospace offers innovative, custom, onboard filtration solutions that help to ensure safe operation, lower weight, protect flight-critical components, and reduce maintenance costs. Our filtration and fluid condition monitoring systems offer robust protection against contamination, the number-one cause of hydraulic system failure.



Smart and tough: AC electronic controller

Created to power hydraulic motor pumps, the AC electronic controller was designed, developed, and integrated entirely by Parker Aerospace. This unique device, which is DO178 and DO254 compatible in commercial aircraft, features a ruggedized enclosure that is environmentally sealed and explosion proof, while providing for the self-removal of heat.

Proprietary sensors and solid-state switches enable the controller to self-monitor health and report it to the aircraft system operating environment.





Filtration systems



Ground service panels



Bootstrap reservoirs



Hydraulic accumulators

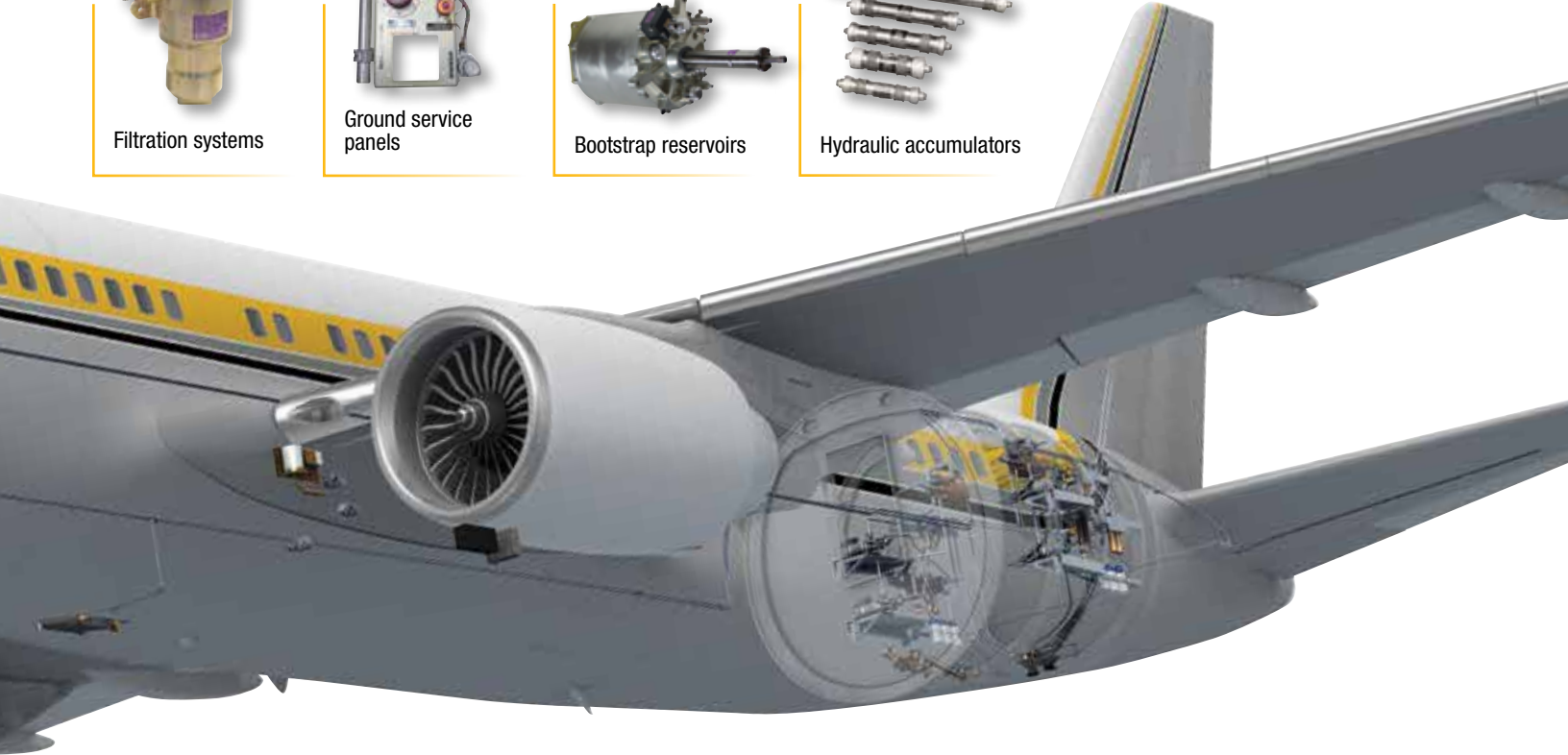

Heater valves



Engine-driven pumps



Kevlar-wound piston accumulators



Direct-current motor pumps



Alternating-current motor pumps



Aft strut fairing module for the Boeing 787

We took the lead to work with 787 partners to preassemble 60 major components, plus hundreds of structural elements and fasteners, into a single deliverable unit. The aft strut fairing module is engineered to quickly interface with the wing for simplified installation, while reducing supply chain infrastructure.

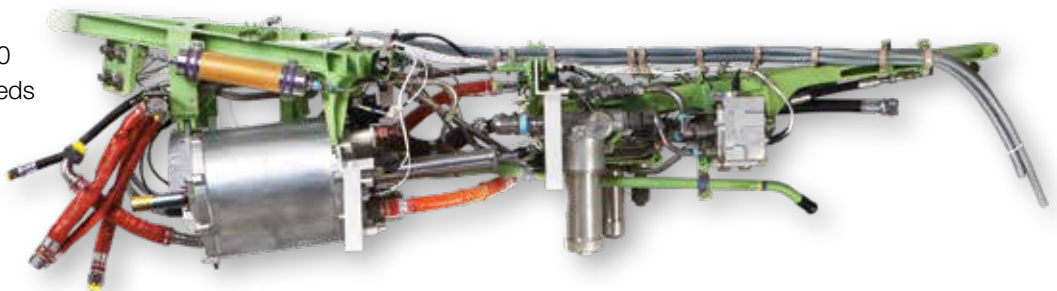

FLUID CONVEYANCE SYSTEMS AND COMPONENTS



Parker Aerospace's broad fluid conveyance portfolio

offers comprehensive solutions built from a proven pedigree and technical depth. From fuel and hydraulic systems, to crashworthy safety systems and engine build-ups, we can supply fluid conveyance for every critical engine and airframe system.

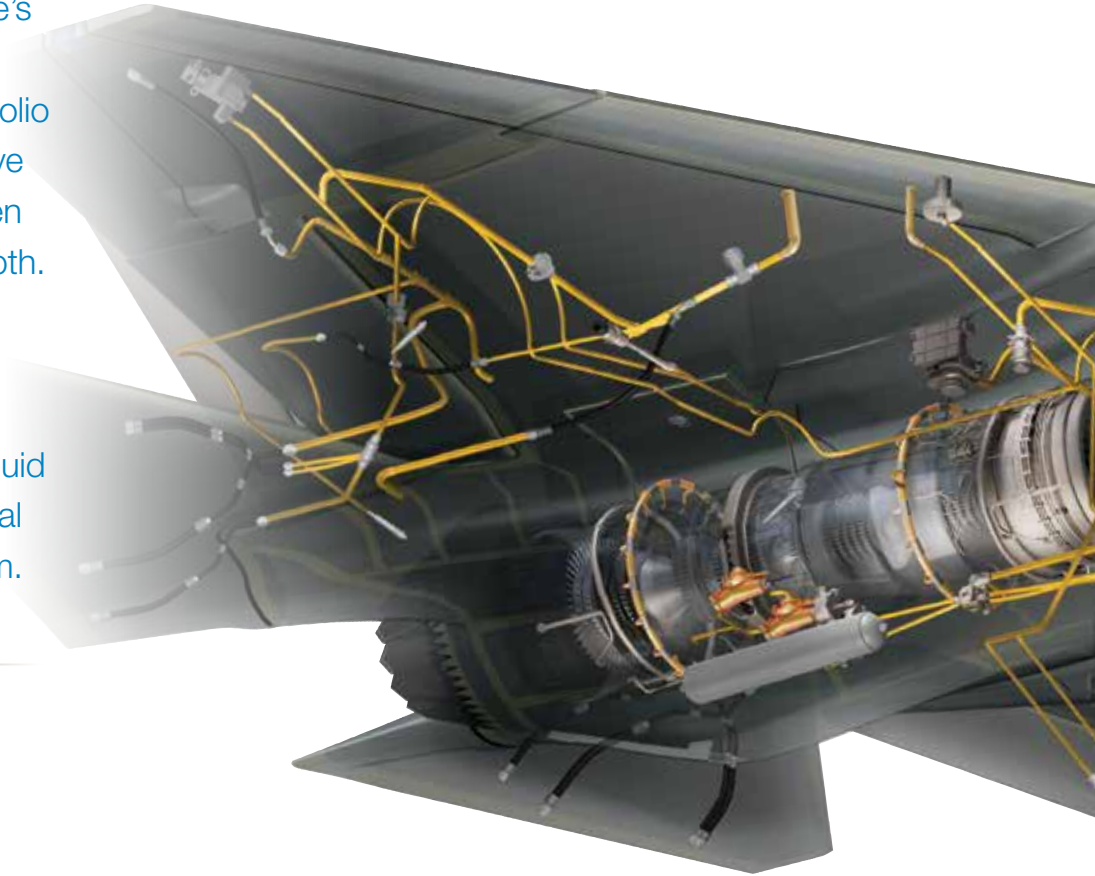

Fluid conveyance for:

- Engine systems
- Fuel systems
- Hydraulic systems
- Pneumatic systems
- Landing gear
- Potable water systems
- Lubrication systems

Water supply subsystems: ducts and tubing

On countless aircraft you will find Parker's composite duct and tubing solutions for potable and waste water applications.

Our products can be integrated with other Parker equipment to deliver a single, highly functional subsystem.

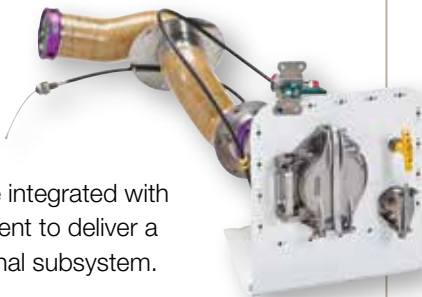

Waste water subsystems

Powerful connections: fuel manifolds

From military to civilian aircraft, Parker Aerospace is at the forefront in fuel conveyance and atomization equipment. Our broad line of conveyance solutions – including tubing, fittings, and flexible hose – combines with our engine manifold design expertise to reduce engine weight, while our fuel nozzle capabilities help to lower CO, CO₂ and NO_x emissions.



Manifolds

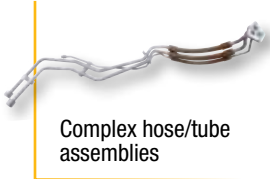

Complex hose/tube assemblies



Hydraulic flow regulators



Hydraulic fuses



PTFE hose assemblies



High-pressure swivel joints



Quick-disconnect couplings

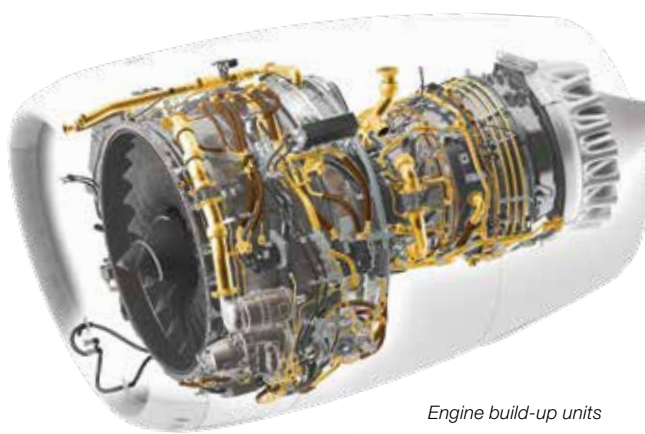

Engine build-up units

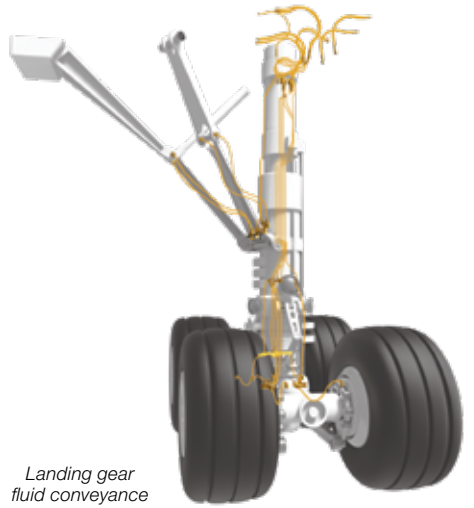

Landing gear fluid conveyance

Let it flow: your single source for all things conveyance

Our capability as a fluid conveyance systems integrator makes it simple for manufacturers to make all the right connections in their aircraft. From hydraulics, anti-icing, ducting, and environmental control, to fuel injection manifolds, and fuel lines, Parker's fluid conveyance capability keeps things flowing reliably throughout aircraft of all types.

PNEUMATIC, LUBRICATION, THERMAL MANAGEMENT, AND ENGINE ACTUATION EQUIPMENT



Engine air systems and actuation



Our pneumatic component and subsystem expertise complements our fuel system and fluid conveyance abilities in the engine environment.

Available for virtually any specification or application, our cost-effective equipment is well proven and reliable. Our engine controls include:

- Nacelle and wing anti-ice, regulating, shutoff valves
- Handling-bleed systems
- Transient-bleed valves
- Secondary air system valves
- Solenoid valves
- Fuel, motor, and pneumatic actuation
- Turbine-tip clearance-control valves
- Heat management system valves

Turbine clearance control actuators



Solenoid banks



Anti-ice pressure-regulating shut-off valves



Intermediate pressure bleed valves



Thermal management systems: high heat removal with greater design flexibility



Parker's thermal management team provides solutions for both heat collection and heat rejection.

Designed as stand-alone solutions or integrated as part of larger environmental control systems, our solutions offer significant size, weight, and power advantages.

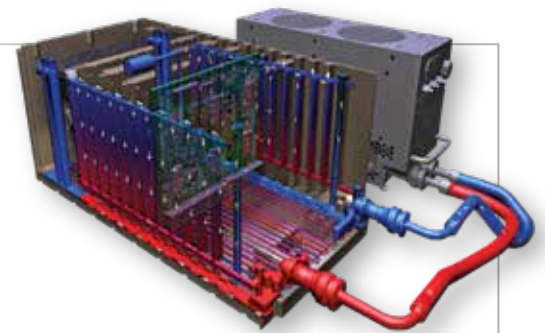

Heat rejection panels



Secondary air system valves



High-pressure turbine clearance control valves



Handling bleed valves



Electric motor-driven positive-displacement pumps



Airframe pneumatics



Our broad portfolio of airframe pneumatic components and subsystems is the ideal place to start for any commercial, military, or regional application. The industry experience and pedigree we offer keep our pneumatic products leading the way while offering low cost of ownership. Products include:

- Anti-ice control and de-icing systems
- Compartment and pre-cooler temperature controls
- Auxiliary power unit load control valves
- Butterfly, coaxial, and check valves
- Bleed air manifold isolation valves
- Air turbine starter control valves
- Temperature-control valves and temperature sensors
- Low-pressure regulators
- Motor-operated shutoff valves
- Pneumatic-operated shutoff valves
- Nacelle cooling/ventilation valves

Lubrication systems



Parker Aerospace lubrication systems deliver rugged performance and value in a small envelope.

From industry-leading lubrication pumps and accessories to oil reservoirs and pump/reservoir systems and subsystems, we support both commercial

and military platforms with solutions that save space and reduce weight, while offering

greater reliability, easier maintenance, simpler operation, and longer life.

Products include:

- Lubrication pumps
- Scavenge pumps
- Air/oil separators
- Oil filtration, conveyance, and bypass/pressure relief valves
- Caps and adapters
- Oil cooling systems
- Oil reservoirs
- Oil level sensors and indicators
- Magnetic debris monitors and drain valves



Engine oil tank

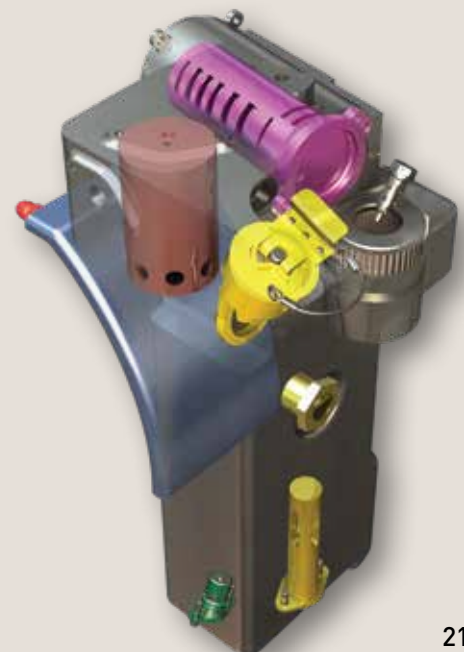

AFTERMARKET SUPPORT



Customer Support Operations is our worldwide organization dedicated solely to keeping your fleet continuously healthy. We are around the globe and on the clock 24/7 with a full spectrum of support services.



Customer response center

As part of our global-reach, local-focus strategy for maintenance, repair, and overhaul, we have elevated our service level to provide a fully staffed service facility available 24/7, worldwide. The goal of our customer response center is to resolve all customer issues at first contact, no matter the location or hour. ■

Parker 360



Global Support Services

- Customer service centers
- Customer response centers
- Joint venture facilities
- Global pooling centers
- Logistics centers
- MRO licensed centers

RESPONSIVENESS



Business Support Services

- Leasing programs
- Flexible warranties
- Asset management
- Life-cycle cost management
- Cost-per-hour programs
- Public-private partnerships

FLEXIBILITY



Maintenance Support Services

- Repair and overhaul
- Field service engineering
- Depot support
- Maintenance support services
- Reliability & maintainability programs
- Technical training
- Onsite services

DEPENDABILITY



Product Support Services

- Worldwide inventories
- Kitting solutions
- AOG support
- Online order status
- Asset management

AVAILABILITY

Worldwide customer service centers

Avon, OH

Camarillo, CA

Devens, MA

Dubai, UAE

Dublin, GA

Elyria, OH

Fort Worth, TX

Glendale, AZ

Hauppauge, NY

Irvine, CA

Jacksonville



Joint ventures to support aftermarket needs

ACE Services is a joint venture between Parker Aerospace and SIA Engineering Company, Ltd, and Parker's center of excellence for the repair and overhaul of aerospace hydraulic components in the Asia Pacific and Middle East regions.



Parker FACRI Actuation Systems

is an AS9100- and NADCAP-approved joint venture between Parker Aerospace and AVIC Flight



Automatic Control Research Institute (FACRI) in Xi'an, China. The facility has a world-class maintenance, repair, and overhaul operation to support Parker Aerospace equipment for the Chinese airline fleet, as well as that produced by other manufacturers. It includes an inventory pooling center and a fluid conveyance distribution hub. ■

Taking military expertise on-base with depot partnership

Public-private partnerships (PPP) with military repair depots allow us to work on site with depot personnel to share best practices in the maintenance of Parker equipment, while streamlining processes and adding efficiency where it's needed most. ■



Photo courtesy of U.S. Air Force

Global pooling centers

Recognizing the critical need for fast, dependable response with spares and product support, Parker Aerospace has established regional pooling centers, strategically located in Xi'an, China; Singapore; Paris, France; and Dubai, UAE. ■



INNOVATION AND ENGINEERING

Our goal is to engineer the success of every aerospace program we touch. We accomplish that by being an engineering-focused organization, devoting significant resources to research and development. By meeting regularly with key customers to determine their priorities, we are able to couple our R&D efforts with real-world demands, developing practical engineered solutions that move aerospace technology forward.

What's driving our blue-sky thinking:

Green technology



- Fuel cells and integrated power systems
- More-electric architecture

Smaller and lighter



- Next-generation manufacturing
- Advanced materials
- Electronics packaging

Improved reliability



- Product improvements & retrofits
- Internet of things
- Health monitoring



Parker's corporate technology ventures facility, Macedonia, Ohio.

Enterprise-wide innovation

To accelerate the understanding of potentially valuable and disruptive manufacturing technology throughout the corporation, Parker has constructed its advanced manufacturing learning and development center in its corporate technology ventures facility in Macedonia, Ohio. The center will help Parker stay at the cutting edge of emerging technologies while managing risk, accelerating knowledge, and providing bottom-line benefits to our customers. ■

Driving advancements in technology

At Parker Aerospace, we are constantly deploying technology advancements across the entire spectrum of current and future airborne platforms. We are integrating technology that enhances performance, reduces weight, and improves quality while remaining affordable and having minimal impact on the environment. ■

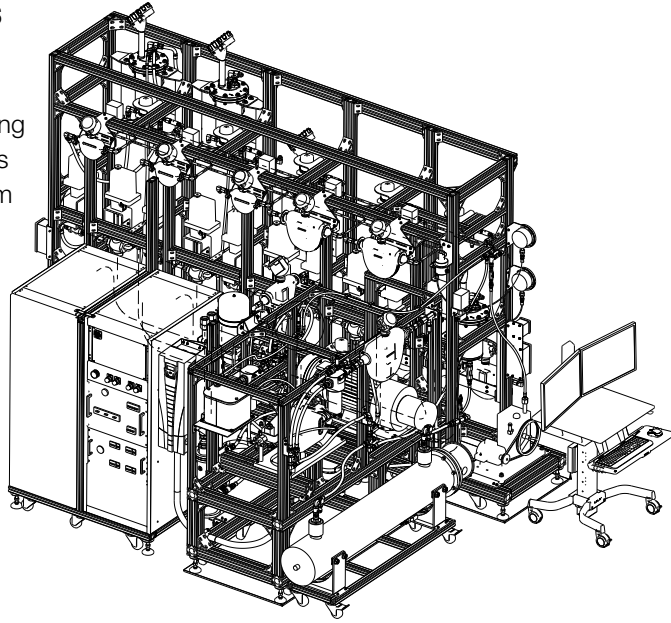

This Parker-built lubrication rig will test the entire lubrication system under actual operating conditions. Profiling the full system allows Parker to optimize its components and customize the system to precisely meet performance requirements.



Automation



Electronics



Robotics



Chemical processing



Automated blaster



Digital x-ray

Parker-tested and -proven

Extensive on-site test capabilities at each of our manufacturing sites help to ensure reliability at entry into service for every program. Parker Aerospace customers often rely on our test results for aircraft certification, eliminating the need of test equipment investment. ■



An air separation module endurance test rig at our Fluid Systems Division in Irvine, California.

Engineering as a core competency

15,000

combined years of engineering experience

43% of salaried workforce are engineers

500+ Parker Aerospace patents

35% of engineers have advanced degrees

100% of **worldwide fleet** supported by technical field service engineers

14 technical fellows and subject matter experts

Corporate synergy: seals, shielding, and filtration solutions

Collaborating with Parker's Engineered Materials and Filtration Groups provides the world-class sealing, electronic shielding, and filtration technologies that enable us to elevate the performance and reliability of our aerospace systems and components. ■



STANDARDIZED EXCELLENCE

One of the benefits of a larger organization, with many experienced minds put to bear on complex challenges, is that our solutions are often best-in-class. These best practices are then systematized and employed across the organization, essentially standardizing excellence.

Program management

All Parker Aerospace program managers are required to obtain certification as Project Management Professionals by PMI®, the Project Management Institute. This certification gives our program managers an in-depth understanding of the discipline and the positive affect it has on customer programs. Certification is held by many of our engineers, contract administrators, and functional managers as well.

In 2016, the program management office at Parker Aerospace was recognized as one of the world's top three by the Project Management Institute. The company puts strong emphasis on the use of standardized, professional program management methodologies through our engineering and production programs. This enables us to manage program costs, schedule, scope, and risks, while aligning with customer and industry standards.



Lean practices are integrated in all we do, going beyond manufacturing to lean enterprise systems that have become a part of our culture and an important aspect of program management. This translates to an overriding philosophy of being fastest to market, with the highest quality, the best value, and the shortest value stream. Lean events, held on the factory floor and in administrative offices, reduce inventories, lead times, turnaround and cycle times, and backlogs for increased productivity, faster and better customer service, and improved yield. ■

Safety	Program management	Supply chain strategies	Lean practices	Quality management	Manufacturing excellence
<ul style="list-style-type: none"> • Zero accidents • Online reporting system • High-performance teams 	<ul style="list-style-type: none"> • Recognized as a global leader by the Project Management Institute • 100% of all program managers are PMP certified • Aligns process with industry standards 	<ul style="list-style-type: none"> • Shared best practices • Common cost objectives • Long-term strategic partnerships 	<ul style="list-style-type: none"> • Consistent methodology • Inventory management • Waste reduction throughout the value stream • Faster throughput 	<ul style="list-style-type: none"> • Six Sigma quality • Zero defect program • Standard detection methods • Reducing variation • Measuring success 	<ul style="list-style-type: none"> • Robotics • Automation • Advanced materials • Advanced production methods



Safety is our standard

Throughout Parker Hannifin Corporation, worker safety is our top priority, and zero accidents is our goal.

We strive to ensure that each of our team members returns home safely at the end of every workday. To that end, Parker Aerospace is implementing the use of Gensuite® safety management processes across all of its facilities to monitor, record, track, and reduce accidents. High-performance teams work diligently to reinforce safety best practices and explore all options to optimize equipment and operations in pursuit of zero accidents. ■



The road to zero: a journey toward perfect

Our Zero Defects program is designed to reduce



manufacturing defects to zero, providing our customers with perfect Six Sigma quality as a standard. Here are some of the steps we're taking toward perfection:

- Strengthening detection methods for containment
- Detecting sources of variation
- Improving process capability
- Employee and supplier engagement, training, and metrics ■



By using strategic supply chain methods, manufacturing production labor and expense is reduced significantly, while overall costs remain competitive.

Supply chain strategies

The best world-class organizations must rely on supply chain partners that are aligned with the organization's goals and work toward the benefit of the end customer. Parker Aerospace and its divisions employ a common, systematic approach to building supply chain excellence that results in lower costs, higher quality, and consistently on-time delivery performance. ■

Manufacturing operations

At Parker Aerospace, our emphasis on operations flow is unparalleled. It is of critical importance, giving our customers the benefit of the highest productivity, line item yields, and optimized personal service.

Based on a practice of continuous improvement to provide 100 percent on-time delivery, we excel at all aspects of operations.

- Full in-house testing and assembly
- Production and delivery based on lean principles, implemented to build upon our existing operational efficiencies
- Consistent training of high-performance work teams, facilitating greater capacity
- Factory transformations that streamline material flow and expedite production and delivery
- Continued investment in the latest processes, tools, and testing equipment

Our operations teams work as one with our program management teams to deliver quality products that consistently and reliably meet our customers' schedules. ■



On the path to your next innovation



Parker Aerospace offers the unmatched leadership,
resources, and expertise to engineer your success.

United States

Avon, Ohio | Camarillo, California | Clyde, New York |
Devens, Massachusetts | Dublin, Georgia | Elyria, Ohio |
Everett, Washington | Fort Worth, Texas | Glendale, Arizona |
Hauppauge, New York | Irvine, California | Jacksonville, Florida |
Kalamazoo, Michigan | Mentor, Ohio | Moncks Corner, South Carolina |
Naples, Florida | Ogden, Utah | Portsmouth, New Hampshire

International

Bangalore, India | Bristol, England | Derby, England |
Dubai, UAE | Guaymas, Mexico | Kuala Lumpur, Malaysia |
Monterrey, Mexico | Montreal, Canada | Nanjing, China |
Paris, France | São José dos Campos, Brazil | Shanghai, China |
Singapore | Toulouse, France | Wiesbaden, Germany | Xi'an, China

Parker Aerospace group and division headquarters



Parker Aerospace Headquarters
6035 Parkland Boulevard
Cleveland, Ohio 44124-4141
+1 216 896 3000



Aircraft Wheel & Brake Division
1160 Center Road
Avon, Ohio 44011-0158
+1 440 937 6211



Control Systems Division
14300 Alton Parkway
Irvine, California 92618-1898
+1 949 833 3000



Fluid Systems Division
16666 Von Karman
Irvine, California 92606-4917
+1 949 851 3500



Gas Turbine Fuel Systems Division
8940 Tyler Boulevard
Mentor, Ohio 44060-2185
+1 440 266 2300



Hydraulic Systems Division
2220 Palmer Avenue
Kalamazoo, Michigan 49001-4165
+1 269 384 3400



Stratoflex Products Division
220 Roberts Cut-Off Road
Fort Worth, Texas 76114-3605
+1 817 738 6543



Customer Support Operations
14300 Alton Parkway
Irvine, California 92618-1898
+1 949 833 3000