

## Specifications:

**Height:** FBO-10 19.0" (48.26 cm)  
with DP Gauge 20.08" (51.0 cm)

FBO-14 23.0" (58.42 cm)  
with DP Gauge 24.08" (61.16 cm)

**Width:** 8.6" (21.8 cm)  
with Bracket 10.7"<sup>±</sup> (27.9 cm)

**Depth:** 8.6" (21.8 cm)  
with Bracket 9.8" (24.9 cm)

**Weight:** FBO-10-DPL: 15 lbs  
FBO-14-DPL: 17 lbs

**Ports:** 1.5" NPT (Inlet and Outlet)

**Service Clearance (Drop-down):** 1.13" (2.87 cm)

**Maximum Pressure:** 150 psi (10.0 bar)

**Max Flow Rate:** 20 gpm (76 lpm) to 65 gpm (246 lpm)  
based on housing, fuel type and element used.

**Fuel Type:** Diesel (up to B20) or Kerosene

**\*\* Filter elements ordered separately unless noted**

## Create a Part Number

Housing Type	Housing Size		Optional Add Ons				
	Required	10" Height **	14" Height **	Delta-P Gauge **	Delta-P Gauge/ Liquid Sight Glass **	25 micron Element Included	Marine Assembly - White Element Included
FBO		10	14	DP	DPL	25M	MA

ASSEMBLY	DESCRIPTION
FBO-10	10" Assy., Drain Valve
FBO-10-DP	10" Assy., Drain Valve, Delta-P Gauge
FBO-10-DPL	10" Assy., Drain Valve, Delta-P Gauge, Sight Glass
FBO-10-25M	10" Assy., Drain Valve, Delta-P Gauge, Sight Glass, 25 micron filter
FBO-10-MA	10" Assy., Marine - Drain Valve, Delta-P Gauge, Sight Glass, Bracket/Fittings, 25 micron filter
FBO-14	14" Assy., Drain Valve
FBO-14-DP	14" Assy., Drain Valve, Delta-P Gauge
FBO-14-DPL	14" Assy., Drain Valve, Delta-P Gauge, Sight Glass
FBO-14-25M	14" Assy., Drain Valve, Delta-P Gauge, Sight Glass, 25 micron filter
FBO-14-MA	14" Assy., Marine - Drain Valve, Delta-P Gauge, Sight Glass, Bracket/Fittings, 25 micron filter

## Dimensions:

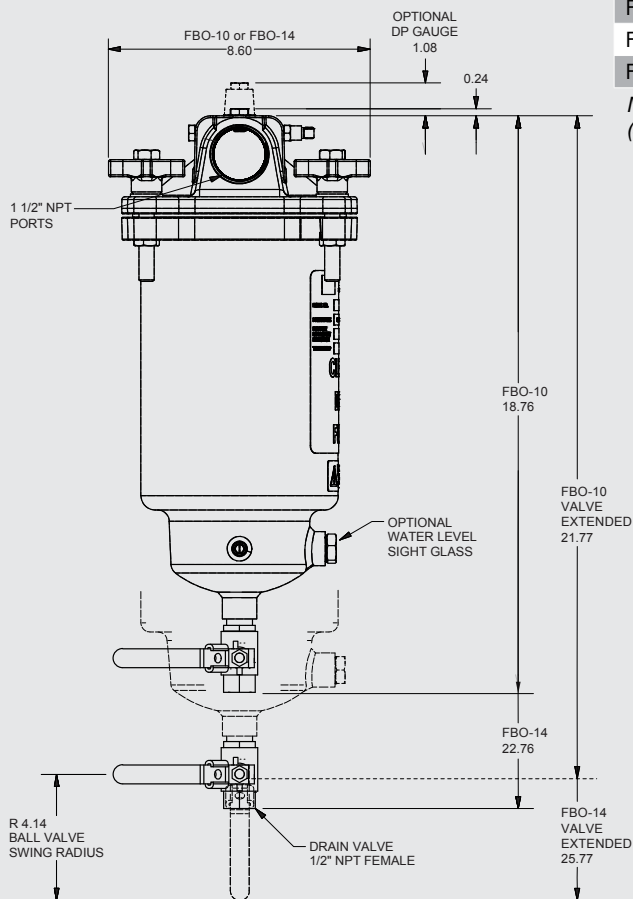

## Mounting Bracket Hole Pattern (Standard on Marine Unit)

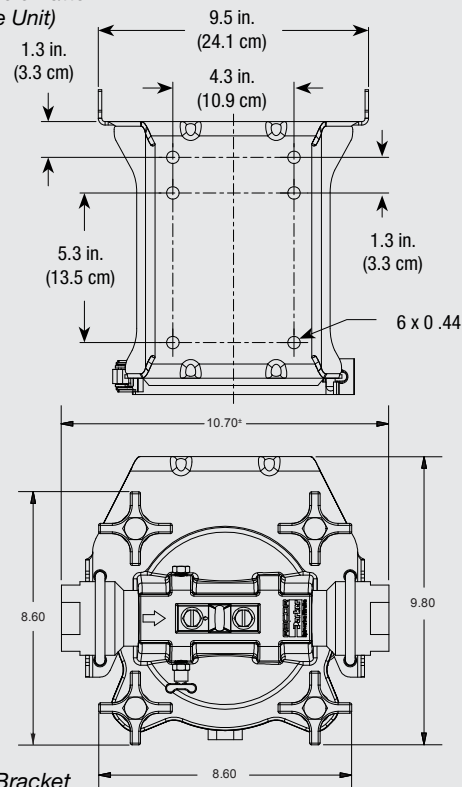

Top - with Bracket



# PARTS

# FBO Series

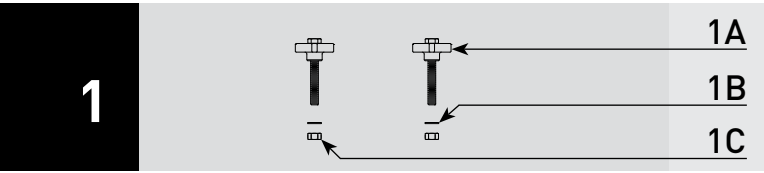

Part #	Description
1A	72712 FBO 1/2" Knob Handle Bolt
1B	FBO 1/2" Washer
1C	FBO 1/2" Hex Nut

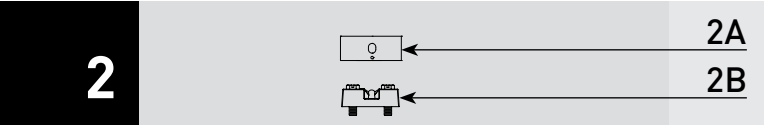

2A	DP Gauge Heat Shield (included in Marine Assembly)
2B	72694 Differential Pressure Gauge (0-15 PSID)
	72783 Differential Pressure Gauge (0-30 PSID)

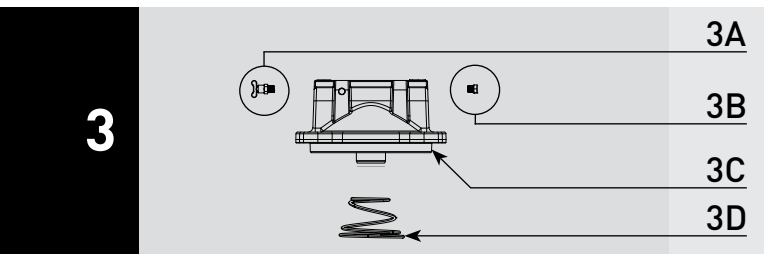

3A	1/8" NPT Brass Vent Valve
3B	1/8" NPT Brass Pipe Plug
3C	FBO Head (Yellow)
	FBO Head (White)
3D	FBO Conical Spring - Stainless Steel

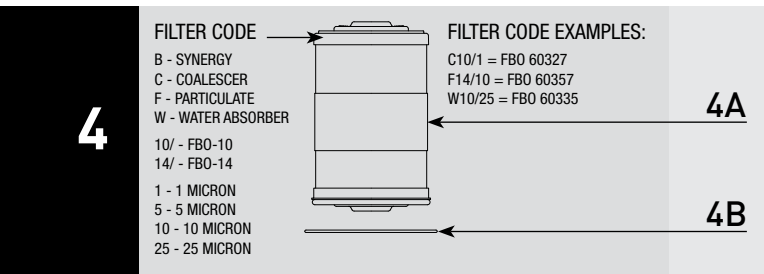

4A	FBO-10 Replacement Elements Includes 4B	Micron	Coalescer/ Separator B C	Particulate F	Water Absorber W
10/	1	FBO 60327	FBO 60330	FBO 60333	
	5	FBO 60328	FBO 60331	FBO 60334	
	10	FBO 60353 FBO 60362 (Synergy)	FBO 60354	FBO 60355	
	25	FBO 60329	FBO 60332	FBO 60335	
4A	FBO-14 Replacement Elements Includes 4B	Micron	Coalescer/ Separator B C	Particulate F	Water Absorber W
14/	1	FBO 60336	FBO 60339	FBO 60342	
	5	FBO 60337	FBO 60340	FBO 60343	
	10	FBO 60356 FBO 60364 (Synergy)	FBO 60357	FBO 60358	
	25	FBO 60338	FBO 60341	FBO 60344	
4B	0V-13	FBO Viton® O-ring			

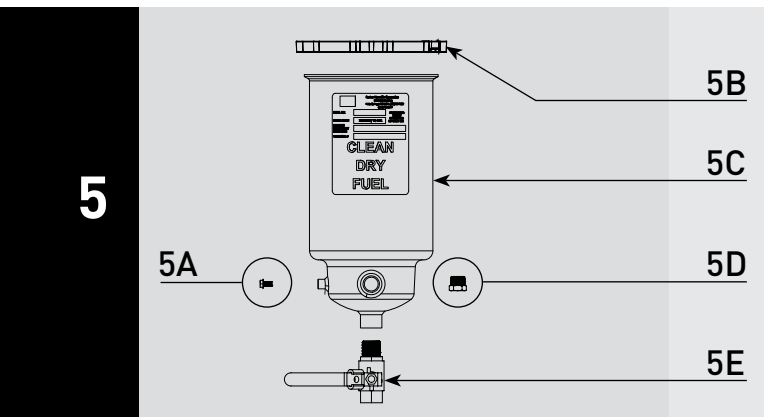

5A	Ground Screw - #10-32 X 3/8 Slotted Hex Head
5B	FBO Flange (Yellow) - Includes 4B
	73153-W-KIT FBO Flange (White) - Includes 4B
5C	FBO-10 Housing (Black)
	FBO-14 Housing (Black)
5D	72710 1/2" NPT Brass Sight Glass
5E	73225-.5 1/2" NPT Brass Locking Ball Valve

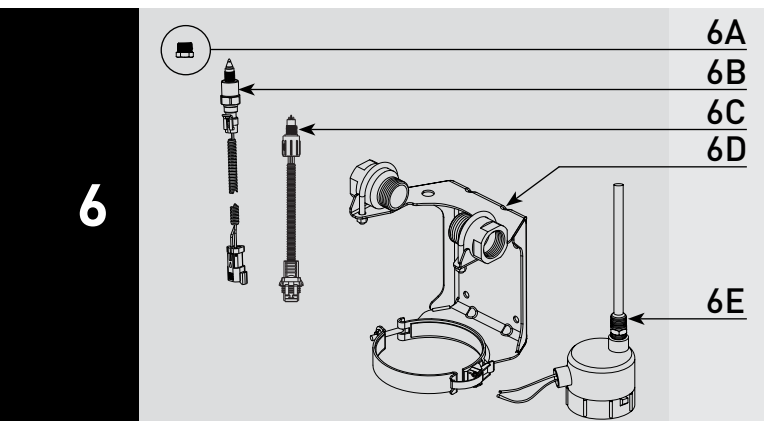

6A	RK18-1656 1/2" NPT Steel Adapter
6B	RK23191-03 Steel - 1/2"-20 Water Sensor - Requires 6A **
6C	RK30880E Plastic - 1/2"-20 Water Sensor - Requires 6A **
6D	73084 FBO Mounting Bracket Kit (Black) with Brass Fittings
6E	FBO-HTR-KIT 45 watt, 120 VAC Heater **

\*\* Note: Not for use in Gasoline Applications