



aerospace
climate control
electromechanical
filtration
fluid & gas handling
hydraulics
pneumatics
process control
sealing & shielding



Racor Filter Division Europe

Commercial Diesel Engine Filtration



Parker's technical resources provide the correct filtration technologies that conform to your requirements. That's why thousands of manufacturers and equipment users around the world rely on Parker Filtration products and people.



Hydraulic, Lubrication & Coolant Filtration
High-performance filtration systems for protection of machinery in industrial, mobile and military/marine applications.



Filtration & Separation
Complete line of compressed air/gas filtration and separation products; coalescing, particulate and adsorption filters in many applications in many industries.



Racor Fuel Conditioning & Filtration
Parker air, fuel and oil filtration systems provide quality protection for engines operating in any environment, anywhere in the world.



Process & Chemical Fluid Filtration
Liquid filtration systems for beverage, chemical and food processing; cosmetic, paint, water treatment; photo-processing; and micro-chip fabrication.



System Contamination Monitoring
On-line dynamic particle analysis, off-line bottle sampling and fluid analysis and measurement of water content polluting the oil in a system.

Parker Filtration's global reputation as a reliable supplier of superior filtration products is the result of a focused and integrated development and manufacturing system.

Parker Filtration consolidates quality filtration products, manufactured for process filtration, air and gas filtration and separation, fuel conditioning and filtration, fluid power products and hydraulic filter products into one broad-based range that covers many markets and most applications, as detailed here.

Racor

The World's Best Filtration starts with the

Over 30 years of innovation, over 30 years of quality...

1969

Diesel Fuel

1969 It all began with a patented, and exceptionally efficient new way to remove water, dirt, rust and algae from diesel fuel.



1975

Cold

1975 Racor pioneers integrated fuel heaters, now standard throughout the industry.

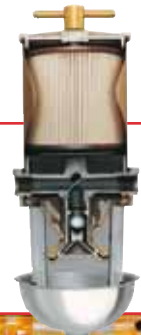

1983

Technology

1983 Aquabloc® filters debut, and Racor Filter/Separators make another significant leap in filtration efficiency.



1984

Protection

1984 The Racor Sentinel System shuts down an engine before a major component failure can cause permanent damage. Sentinel remains the preferred all mechanical engine control system.



1985

Growth

1985 Racor becomes a division of Parker Hannifin Corporation, further strengthening one of the world's most respected brands.



1987

Standard Equipment

1987 The first Navistar powered Ford E Series and F Series vehicles roll off the production line with the revolutionary, compact and flexible Racor Spin On Series.

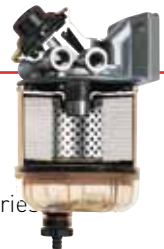

1989

Quality

1989 Racor earns Ford Q1 certification, the first in a series of quality awards from one of the world's leading engine and equipment manufacturers.



1991

The Environment

1991 Along with protecting engines, Racor makes products that protect the environment. Lifeguard is a marine fuel/air separator that prevents fuel from escaping overboard from vent lines during refuelling.



1992

Oil

1992 Every bit as vital and every bit as dirty as fuel. The Racor solution is an ingenious one, a cleanable oil filter that puts an end to frequent filter changes and disposal.



Contents

1994

Air

1994 Engines gasping for a breath of fresh air breathe easy with the introduction of synthetic, multi stage Racor "twice the life" air filters.



1995

CCV Products

1995 Racor starts cleaning up engine rooms with a crankcase ventilation system that keeps oily blow-by from damaging turbo chargers and other precision components.



1996

Plant expansion

1996 In addition to the world class manufacturing facility in Modesto, Racor opens locations in Oklahoma, South Carolina, Brazil, Korea and South Africa. In Europe Morley, West Yorkshire in the UK becomes the centre of excellence in Europe.



1997

Racor Hydrocarbon

1997 Racor Hydrocarbon Filters and Vessels debut – offering customers flow rates to 1000 gpm and higher.



2000

UK Facility

2000 Having moved out of Morley into a purpose built factory at nearby Dewsbury in 1998, Racor sees significant growth in Europe. 2000 saw the expansion of manufacturing capability to include all spin on series filters, and the establishment of a state-of-the-art design and test, research and development facility.



2001

Global OEM

2001 Racor continues to forge long term relationships with Global OEM companies to produce sound, cost effective engineered solutions to meet specific application requirements.



2002

High performance air filters

2002 Racor purchases Farr opening up opportunities in medium and heavy duty Engine Air applications.



2007

Ultra high efficiency CCV integration

2007 European design and engineering consolidation to provide CCV integrated OEM solutions.



2008

Lab and engine test facilities

2008 A major investment in Dewsbury facilities ensure technical resources are in place to support customer needs. Parker Racor purchases Village Marine-Water filtration desalination products.



The most trusted name in engine protection

Racor technology takes the guesswork out of engine protection and Racor manufacturing quality and attention to detail ensures every customer gets the filtration and separation solution they are looking for.

To make product selection easier, Racor's extensive range has been catalogued into four market/ application groups detailed below.

Hydrocarbon Filter Vessels and Elements

From the refinery to the injector, at the terminal and on the forecourt, Racor has a hydrocarbon filter vessel and element solution to meet your fuel delivery needs.



Ref: FDRB130GB1

Commercial Fuel Filtration

Everytime you add fuel, you add millions of tiny contaminants...small enough to be invisible, but big enough to destroy injectors, pumps and profitability. Racor's industrial and automotive product range of customer proven spin-on filter/separators, turbine fuel filters and crank case ventilators are the solution.



Ref: FDRB129GB1

Engine Air Filtration

Systems Fresh air. That's what Racor filtration is all about. Because when engines breathe easier they perform better with more power, more torque and with improved fuel economy. Whatever your application, there's a Racor Air Filtration system that will help you and your engine breathe easy.



Ref: FDRB172UK

Leisure Marine and Commercial Marine

Filtration Ask a sailor about engine protection. About filtration, about reliability and performance. Whether they are the master of a superyacht, sailboat, fishing boat or tug, the chances are the one word answer will be the same as it has been for more than three decades...Racor. Marine filtration products trusted across the seven seas.



Ref: Commercial Marine FDRB175UK
Ref: Leisure Marine FDRB134GB1

For further information email:
filtrationinfo@parker.com

Racor Out in Front	4-5	OEM CCV Solutions	19	CCV Systems	26-29
Diesel and Petrol Spin-on Series	6-13	CNG and LPG Filtration	20-21	ECO III & ECO SE	30-31
P-Series	14-15	FBO Filters Vessels	22-23	Accessories	32-33
Turbine Series & Primer Pump	16-18	RVFS Series	24-25	Installation examples/other products	34-35

The World's Best Filtration Starts with the

Whether you operate a truck, bus, generator or pump set, you need to know that every time you switch on the ignition you will hear the engine fire into life, each time and every time. There is no better way to ensure engine reliability than with good quality filtration. Whatever and wherever your application, we have a system which will meet your requirements.

Racor Closed Crankcase Ventilation

To meet emissions legislation and also to keep engine bays and air filters clear of oil, engine blow by gases emanating from the crankcase are fed back into the air intake before the turbo charger.

Fuel Filtration Water Separators (FFWS)

Fuel Contamination, either in the form of dirt or water will find its way into your fuel system however careful you are. With modern engines now injecting fuel at anything up to 2000 bar, and injector tolerances being measured in microns, it is hardly surprising that even a small amount of dirt or water corrosion can start a problem. Water or particulate can cause microscopic surface damage which is then focused on by the high pressure flow, to cause significant wear which will eventually lead to reduced efficiency and complete break-down. Several \$100 of filtration over an engines life can save \$1000's in engine re-fits let-alone down-time. Parker Racor offer what is widely accepted as the industry bench mark premium product, why risk anything less.

Working to Efficiency standards:

ISO TR 13353, ISO TS 13353,
ISO 19438, SAE J 1985,
SAE J 905,

Water Separation Standards:

ISO 4020 6.5, SAE J1839,
SAE J 1488]

FFWS

1. 400 Series FFWS
2. 600 Series FFWS
3. 200 Series FFWS
4. Turbine FFWS
5. Top Loader
6. P-Series Pump FFWS
7. RAC gasoline Series

Fuel Dispensing Filters

Water and dirt are often introduced into fuels during fuel transfer and storage, therefore to clean fuel before it enters the fuel tank, will reduce contamination, protect your injection system and save money in the long-run.

Fuel Delivery

8. FBO FFWS
9. RVFS FFWS



World's Best Engineering

However these gases are full of soot laden oil mist, which will coat the turbo turbine blades and more importantly coat the intercooler, reducing efficiency and causing over heating. Racor's CCVs solve this problem.

They are some of the most efficient available and have upstream crankcase pressure regulation as opposed to a turbo vacuum limiters, which other manufacturers are forced to employ.

- CCV
- 10. CCV 3500
- 11. CCV 6000

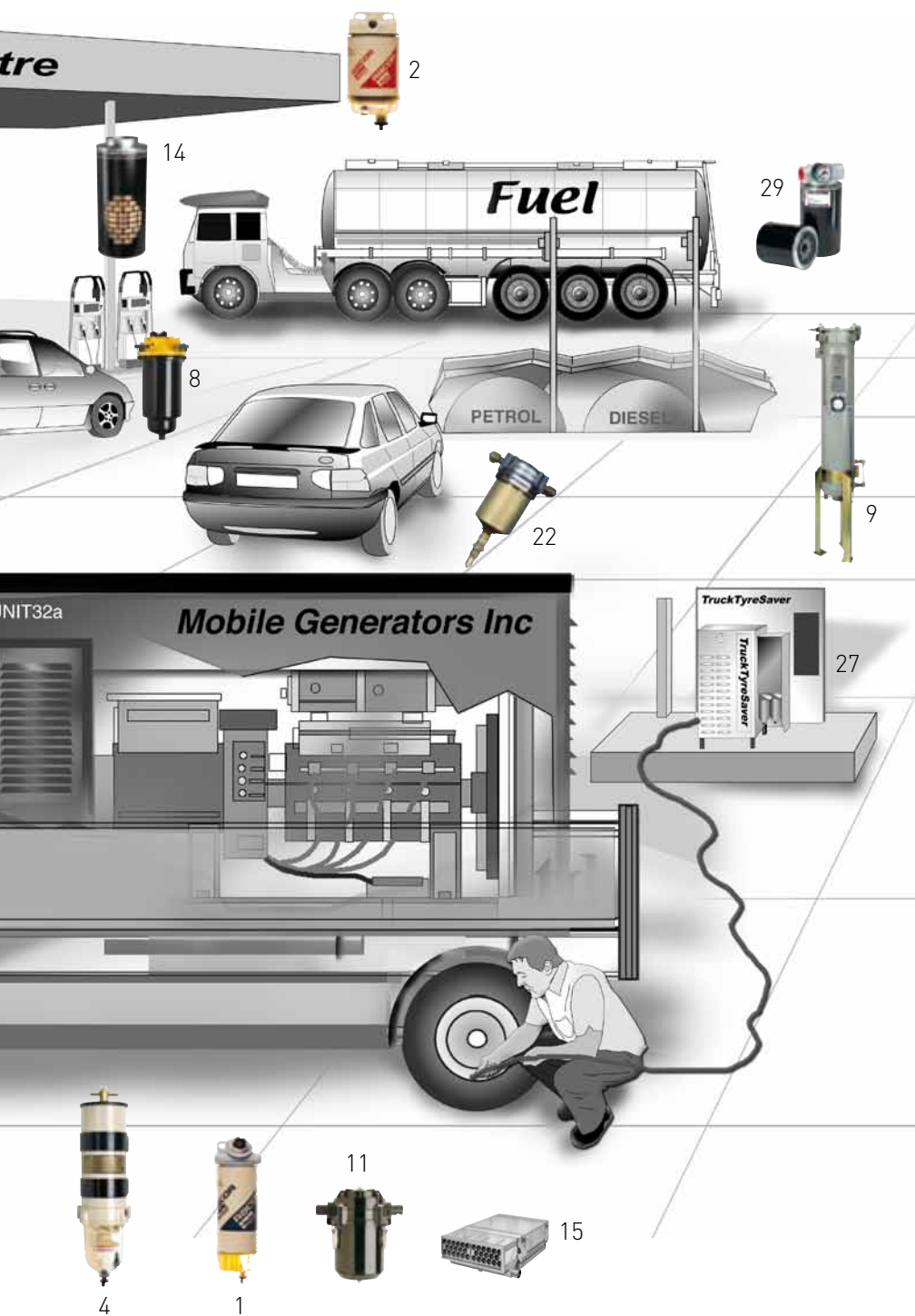

Air Filters

High efficiency air filters will allow your engine to breath clean dry air, which will stop damaging particulate from entering the engine and oil systems. In very dirty atmospheres special static and active pre-cleaners are available to stop media elements from being prematurely clogged.

Air Filters

- 12. AF Air Filter
- 13. Pamic Air Filter
- 14. ECO Air Filter
- 15. Dynacell Air Filter
- 16. Cabin Air Filters

Oil Filters

Parker Racor is able to develop with boat and marine engine manufacturers oil filtration system solutions based either on cartridge elements or spin-on canister filter assemblies.

International Oil, Fuel and Cooler Module

17. A total system approach that utilises 17 functions in one filtration module developed for OEM's. The module has a fuel and oil top loading filter cartridge ensuring quality and preventing design features being copied. The oil, fuel and cooler module is used in conjunction with the HFCM OE version of the P Series.

Racor Additives

For long term fuel stability, elimination of Bacterial growth or engine performance improvement, Racor have an additive to suit your needs.

Racor Additives

- 18. Fuel/Oil/Coolant Additives

Additional Products

- 19. Hydraulic spin on
- 20. Parker Par-Fit
- 21. Replacement Elements
- 22. LPG/CNG Filters
- 23. ABL
- 24. EAB
- 25. Particle Counter
- 26. Multiclamp
- 27. Nitrogen Tyre Saver
- 28. Green Dust Cap Nitrogen Filled
- 29. Transmission Filter

At the heart of the filter is the filter paper or media, which is constructed from a special blend of mixed fibre sizes, to achieve the highest possible efficiency whilst maximising capacity and life. The media is impregnated with special resins to ensure durability and separation performance. Product is built in an ISO TS 16949 quality system environment to ISO 14001 Environmental requirements. Leading global engine manufacturers recommend Racor to protect their engines, why risk anything less.

Diesel and Petrol Spin-On Series

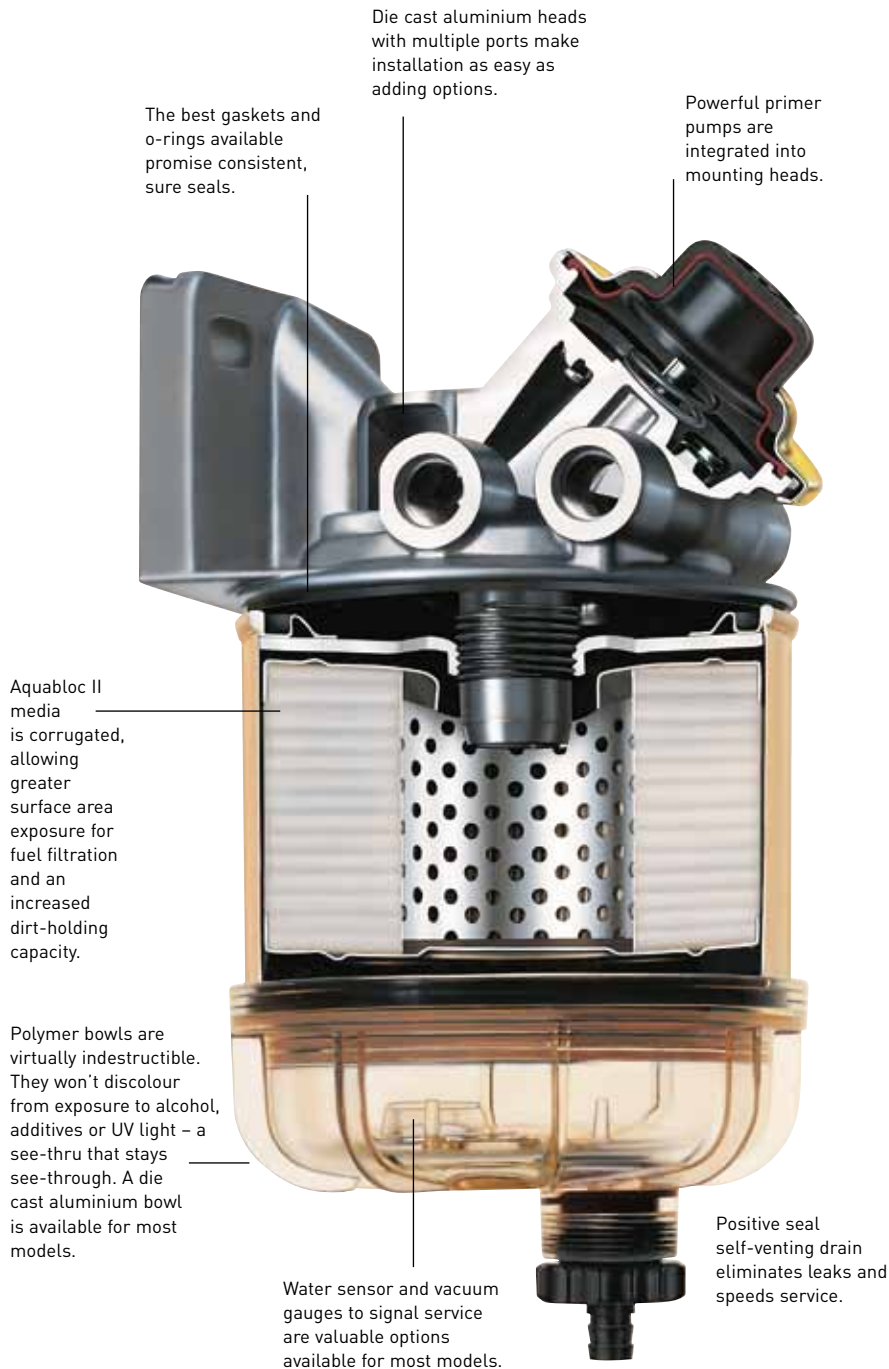

100 Series

110A - 120A - 140

Maximum protection in minimum space.

The 110A is designed for fuel injected petrol engines with high working pressures and also can be used on diesel engines. A metal housing is standard.

Other models in the 100 Series, the 120A and 140, offer reliable protection for smaller diesel and petrol engines used in generator sets, pressure washers and other equipment. Their compact size fits tight mounting locations and multiple ports offer installation flexibility.



200 Series

215 - 230 - 245

Improved for greater versatility.

The 215, 230 and 245 filter/separators come standard with an integral priming pump and a new see-through contaminant bowl which can operate in applications up to 30 psi. Another design upgrade is the optional 200-watt in-bowl heater for colder operating conditions. Applications include light duty and medium duty trucks and vehicles, construction, agricultural and other diesel powered equipment.





Diesel Spin-On Series

4120 - 6120 - 3150 - 3250

High Capacity Fuel Filtration

High flow applications need not suffer with high maintenance... and Racor offers a range of ultra-high capacity, highly efficient fuel filter/water separators that also deliver spin-on convenience. As you'd expect, Aquabloc II media is standard, and all units provide flexibility in options to customize and meet specific operating conditions.



3250 R30
High flow filter
water separator

Bowl removal
wrench available
22628



400 Series

445 - 460 - 490 - 4120 - 4160

A powerful, integral primer pump makes service quick and easy.

The standard equipment primer pump tops the list of extensive options that allows bus fleets, truck fleets, RV owners and others to tailor a filter/separator system specifically to their operating requirements. These options include a choice of three micron rating for the Aquabloc filter element, 300 watt in head PTC (positive temperature coefficient heater) water sensor and flow rates up to 600 l/hr (160 US gph).



600 Series

645 - 660 - 690 - 6120

Maximise engine protection with a low profile, easy to fit filtration system.

With all the features of the 400 Series, the 600 Series offers engine owners an economical system for applications where an integral primer pump is not needed. Flow rates up to 600 l/hr (160 US gph), in bowl heater and water sensor are all available options.



100 Series

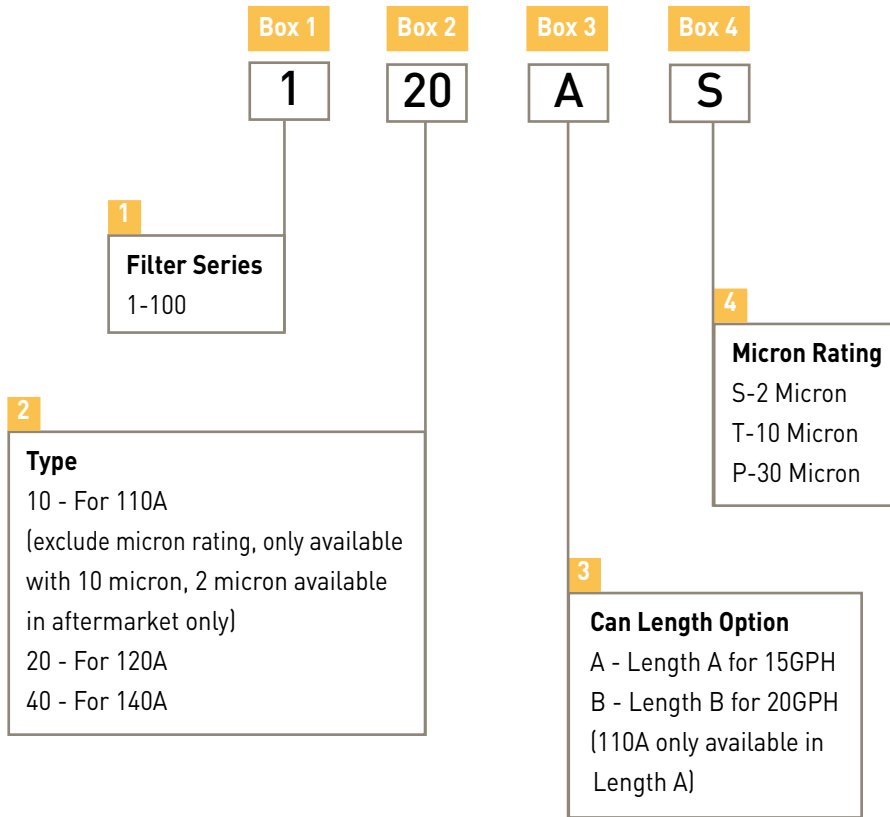

Model	110A	120A	140A
Maximum Flow Rate *1	57 L/hr (15 G/hr) Diesel 132 L/hr (35 G/hr) Petrol	57 L/hr (15 G/hr) Diesel 132 L/hr (35 G/hr) Petrol	57 L/hr (15 G/hr) Diesel 132 L/hr (35 G/hr) Petrol
Petrol/Diesel *2	Both	Both	Both
Maximum Pressure Bar *3	6.9	0.5	0.5
No. of Ports	4	4	2
Port Size	1/4" - 18 NPTF	1/4" - 18 NPTF	1/4" - 18 NPTF
Integral Primer Pump *4	No	No	No
Water Sensor Option *5	Yes	Yes	Yes
Electric Heater Option *5	No	No	No
Height mm	152	166	152
Width mm	81	81	81
Depth mm	81	81	81
Weight Kg	0.59	0.5	0.5

*1 Flow rate given in US gph 1US Gallon = 0.833 Gallon

*2 Metal Bowls must be used for petrol installations

*3 Pressure installations are applicable up to the maximum Pressure shown

200 Series

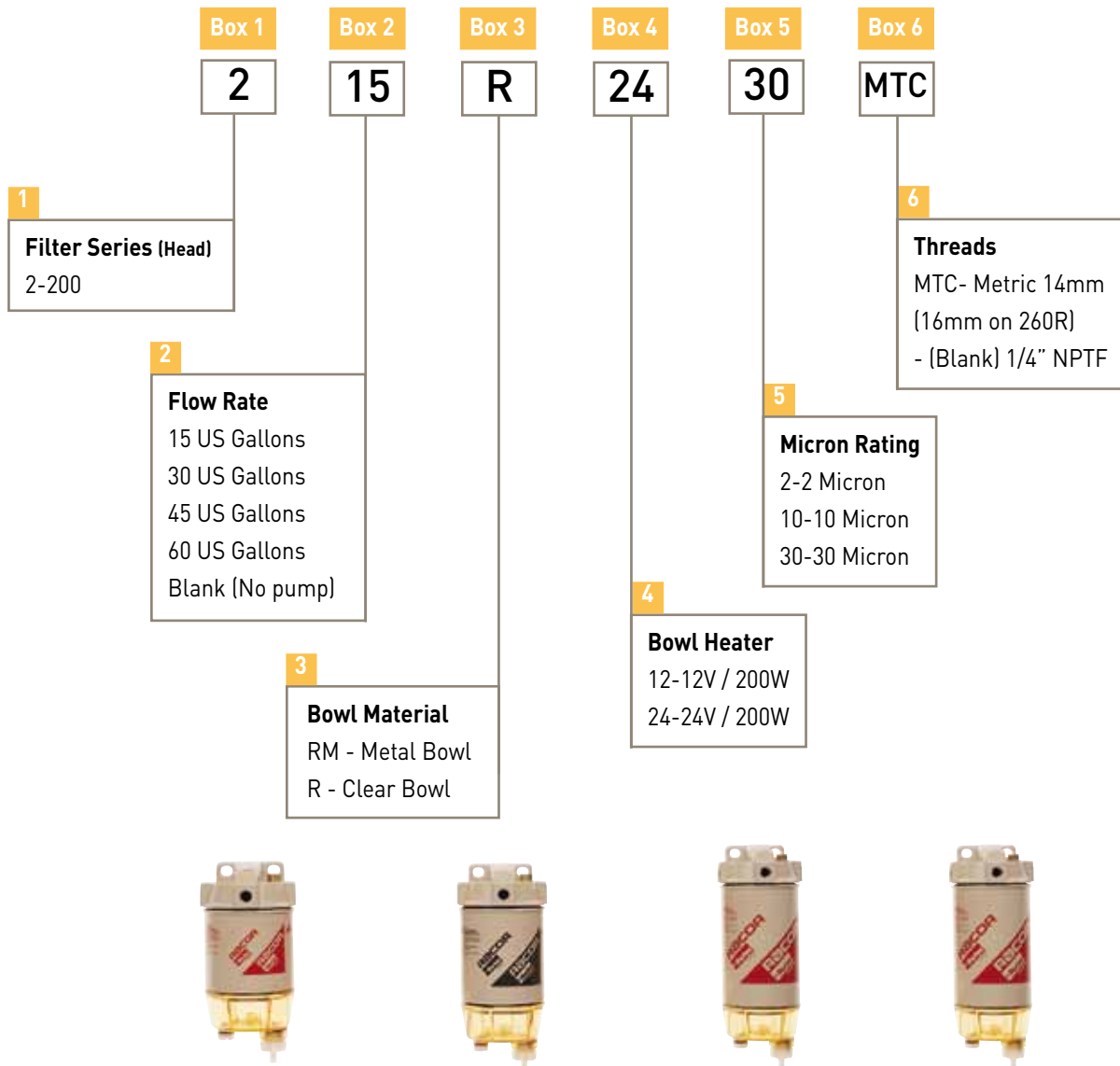

Model	215	230	245	260
Maximum Flow Rate *1	57 L/hr (15 G/hr) Diesel	114 L/hr (30 G/hr) Diesel	170 L/hr (45 G/hr) Diesel	227 L/hr (60 G/hr) Diesel (65 G/hr)
Petrol/Diesel *2	Diesel	Diesel	Diesel	Diesel
Maximum Pressure Bar *3	2.06	2.06	2.06	2.06
No. of Ports	3	3	3	3
Port Size	M14 x 1.5 - 1/4NPTF	M14 x 1.5 - 1/4NPTF	M14 x 1.5 - 1/4NPTF	M16 x 1.5 - 1/4NPTF
Integral Primer Pump *4	Yes	Yes	Yes	No
Water Sensor Option *5	Yes	Yes	Yes	Yes
Electric Heater Option *5	Yes	Yes	Yes	Yes
Height mm	211	229	267	267
Width mm	102	102	102	102
Depth mm	102	102	102	102
Weight Kg	0.5	0.8	1	1

*4 Models with integral priming pumps are not recommended for petrol applications

*5 Not for use with petrol applications

400 Series

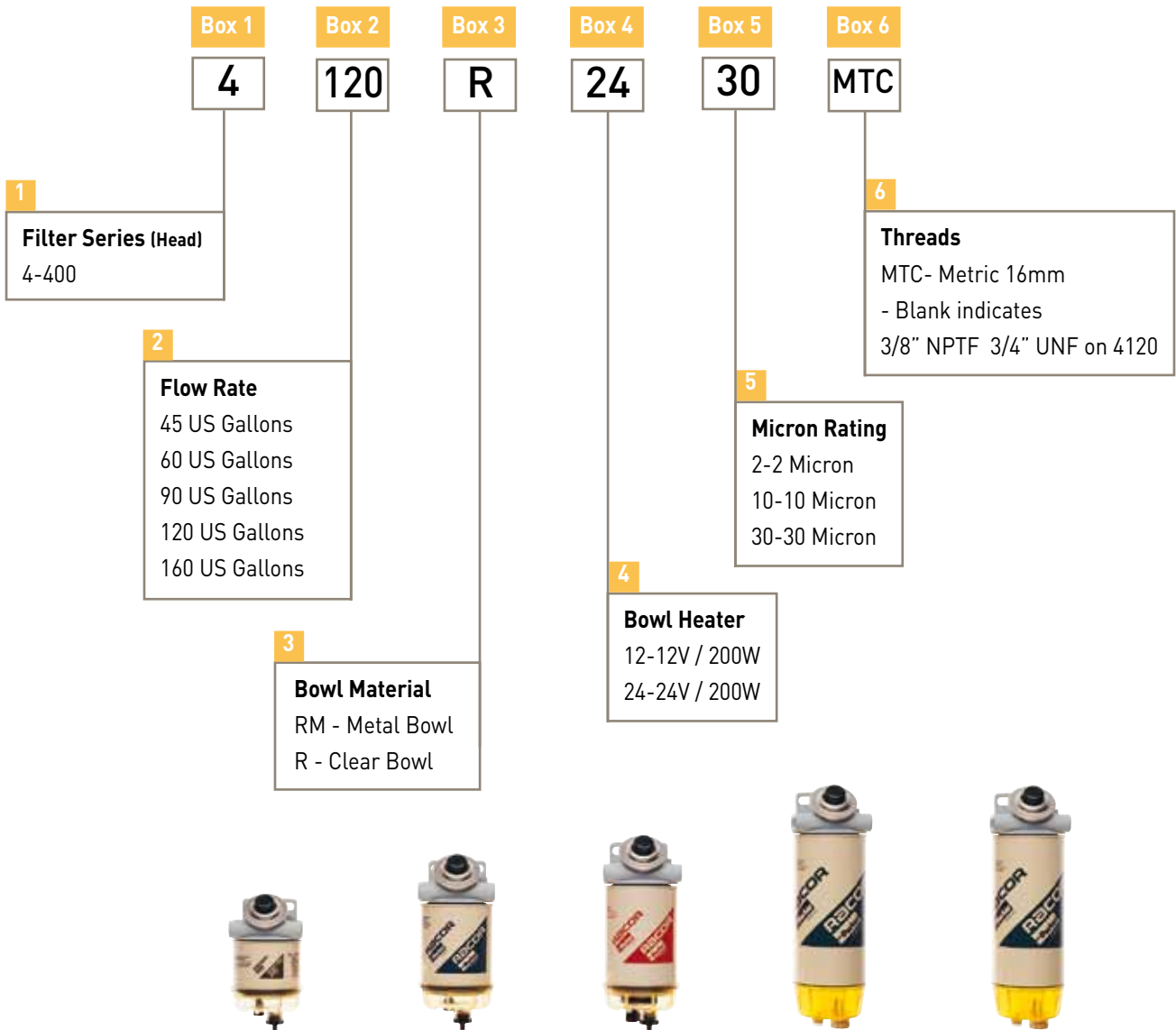

Model	445	460	490	4120	4160
Maximum Flow Rate *1	170 L/hr (45 G/hr)	227 L/hr (60 G/hr)	341 L/hr (90 G/hr)	454 L/hr (120 G/hr)	600 L/hr (160 G/hr)
Petrol/Diesel *2	Diesel	Diesel	Diesel	Diesel	Diesel
Maximum Pressure Bar *3	2.06	2.06	2.06	2.06	2.06
No. of Ports	4	4	4	4	4
Port Size	M16 x 1.5 - 3/8NPTF	M16 x 1.5 - 3/8NPTF	M16 x 1.5 - 3/8NPTF	M16 x 1.5 - 3/4SAE	M16 x 1.5 - 3/4SAE
Integral Primer Pump *4	Yes	Yes	Yes	Yes	Yes
Water Sensor Option *5	Yes	Yes	Yes	Yes	Yes
Electric Heater Option *5	Yes	Yes	Yes	Yes	Yes
Height mm	236	279	300	381	381
Width mm	114	114	114	114	114
Depth mm	121	121	121	121	121
Weight Kg	1.1	1.3	1.4	1.8	1.8

*1 Flow rate given in US gph 1US Gallon = 0.833 Gallon

*2 Metal Bowls must be used for petrol installations

*3 Pressure installations are applicable up to the maximum Pressure shown

600 Series

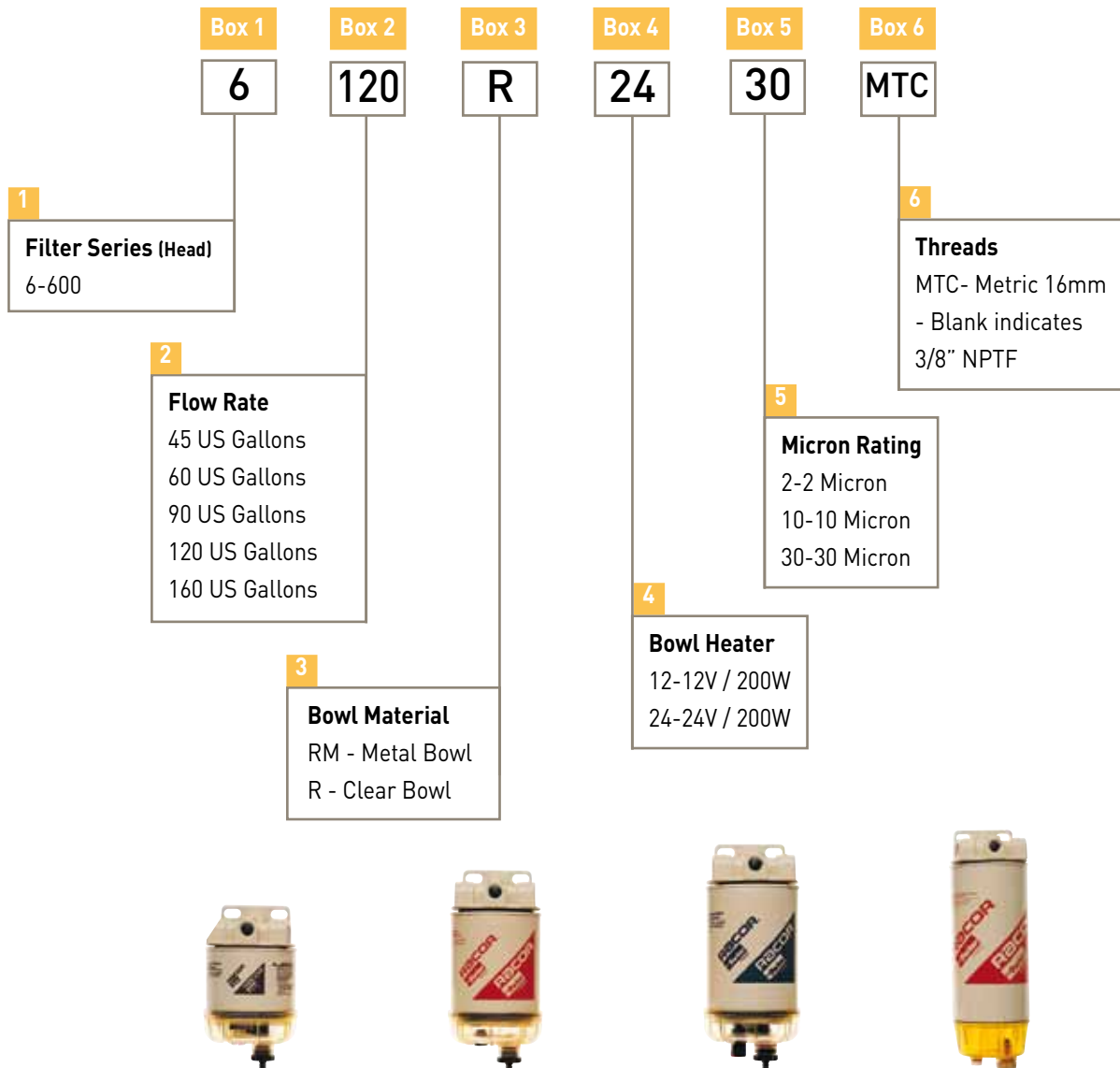

Model	645	660	690	6120
Maximum Flow Rate *1	170 L/hr (45 G/hr)	227 L/hr (60 G/hr)	341 L/hr (90 G/hr)	454 L/hr (120 G/hr)
Petrol/Diesel *2	Both	Both	Both	Both
Maximum Pressure Bar *3	2.06	2.06	2.06	2.06
No. of Ports	7	7	7	7
Port Size	M16 x 1.5 – 3/8NPTF	M16 x 1.5 – 3/8NPTF	M16 x 1.5 – 3/4SAE	M16 x 1.5 – 3/4SAE
Integral Primer Pump *4	No	No	No	No
Water Sensor Option *5	Yes	Yes	Yes	Yes
Electric Heater Option *5	Yes	Yes	Yes	Yes
Height mm	215	259	284	359
Width mm	114	114	114	114
Depth mm	114	114	114	114
Weight Kg	1.07	1.17	1.2	1.8

*4 Models with integral priming pumps are not recommended for petrol applications

*5 Not for use with petrol applications

Spin-on Replacement Filter Cans

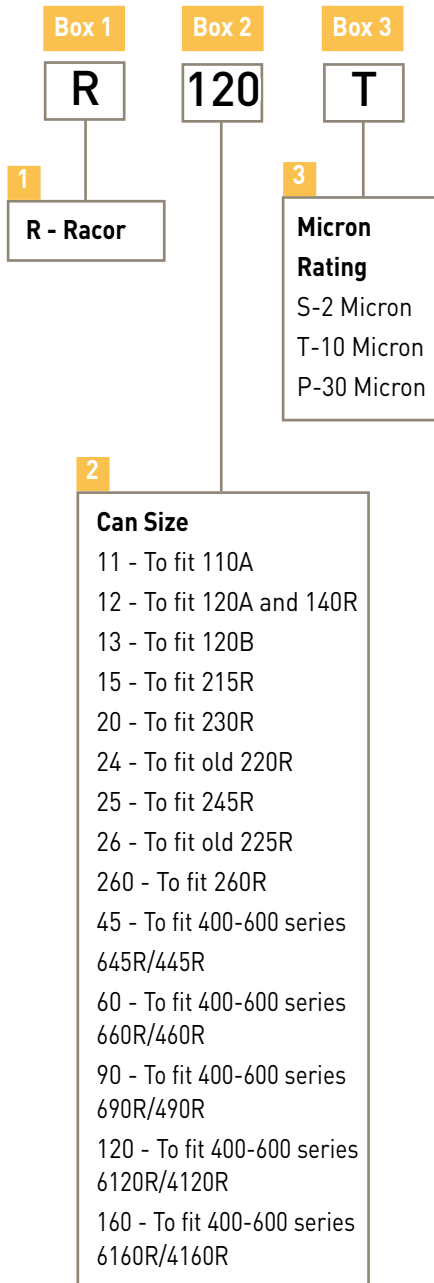

Fuel Filter / Water Separators with Intergrated Priming Pump

The Racor 700 Series is equipped with state-of-the-art fuel pumps with DC motors. The 12V roller-cell fuel pump offers the benefit of an electric on-demand priming pump. In the 24V brushless version, the motor shaft directly drives the gerotor, creating a unique, positive displacement pump. The gerotor has fewer parts than gear or vane pumps, and the sensorless control technology of the DC motor make this product the most reliable filter and pump assembly on the market. The 24V pump assembly is ideal for tough on-engine applications. For off-engine mounting, the 12V pumps are a more economical alternative.



Product Features

- Aluminium filter head with integral mounting bracket and four ports (2 inlets and 2 outlets) with 7/8"-14 SAE O-ring threads.
- 100 micron prefilter screen.
- 12 volt or 24 volt electronic priming pump.
- Vent valve to purge air during fuel priming.
- Replaceable Aquabloc®II spin-on element.
- Reusable, see-thru collection bowl.
- Self-venting water/contaminant drain.
- Water-in-fuel (WIF) sensor/detection probe.

Problem

- Filters are often installed in hard to reach places for re-priming.
- Air can get in fuel lines during element change-out or storage.
- Pre-filling filter can be messy.
- Distance between tank and filter can be inconvenient for hand priming.

Solution

Racor 700 Series Integrated Fuel Filter/Water Separator with a two stage filtration and re-priming system.

- Simplifies service
- No messy pre-filling
- Protects engine
- No lag in starting engine
- Fast and safe re-priming

How it works

The 700 Series pump/fuel filter water separator assemblies are two stage filtration and re-priming systems. These complete fuel management systems isolate contaminants present in diesel fuels and traps them prior to reaching the fuel injection system, protecting the engine's fuel system from costly and premature failure.



Ordering and Specification



Model	745R30	760R30	790R30 ¹	7125R10 ¹ (10 micron)	7125R30 ¹ (30 micron)
Maximum Flow Rate	170 L/hr (45 G/hr)	227 L/hr (60 G/hr)	341 L/hr (90 G/hr)	454 L/hr (120 G/hr)	454 L/hr (120 G/hr)
Replacement Element	R45P	R60P	R90P	R125T	R125P
Height	10.8in / 25.7cm	11.8in / 28.4cm	12.8in / 31.2cm	15.8in / 40.1cm	15.8in / 40.1cm
Width	4.3in / 11.0cm	4.3in / 11.0cm	4.3in / 11.0cm	4.3in / 11.0cm	4.3in / 11.0cm
Depth	6.5in / 16.5cm	6.5in / 16.5cm	6.5in / 16.5cm	6.5in / 16.5cm	6.5in / 16.5cm
Weight	4.5 lbs / 2.0kg	5.5 lbs / 2.5kg	6.5 lbs / 3.0kg	7.7 lbs / 3.5kg	7.7 lbs / 3.5kg
Clean Pressure Drop	0.25 psi / 1.7 kPa	0.25 psi / 1.7 kPa	0.25 psi / 1.7 kPa	0.25 psi / 1.7 kPa	0.25 psi / 1.7 kPa
Operating Temperature	-40° to +225°F (-40° to +107°C)				

¹ The 700 Series comes standard with a 12 volt brushed pump assembly. To order the 24 volt brushless pump assembly insert 24 at the end of the 790 or 7125 part numbers. (example: 790R3024)

Racor Fuel Conditioning Module

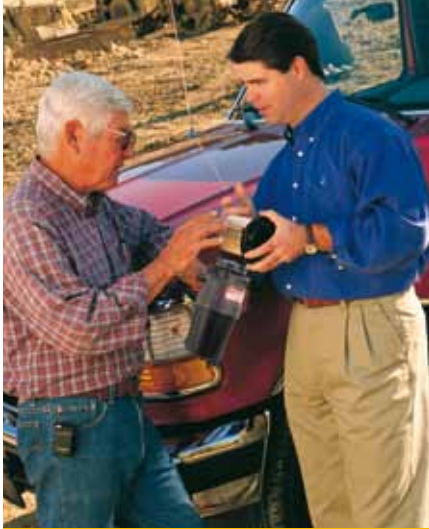

Durable, 12V DC roller-cell electric fuel pump offers the benefit of an electric, on-demand, priming pump.

High performance Aquabloc II cartridge-style filter media is environmentally friendly and incinerable.

Thermostatically controlled PTC style electric (150-watt) heater facilitates cold weather starting.



Water-in-fuel (WIF) sensor alerts the operator when service is required. Under-dash control module for pump and water sensor operation is included with pump option.

Contaminant collection bowl with self-venting drain is both removable and reusable.

The P-Series diesel fuel conditioning module (for vacuum side applications only) was developed for application in any diesel engine fuel injection system. P-Series assemblies are available in three sizes and all feature 3/8" NPT fuel ports. This innovative and modular fuel filter/water separator incorporates low-pressure fuel system components into a single package.



Robust roller-cell electric fuel pump ensures consistent fuel delivery at a variety of engine speeds.

Thermostatically (10°C / 50°F – 26°C / 80°F) controlled PTC style electric fuel heater (200 watts at 12V DC) facilitates cold weather starting.

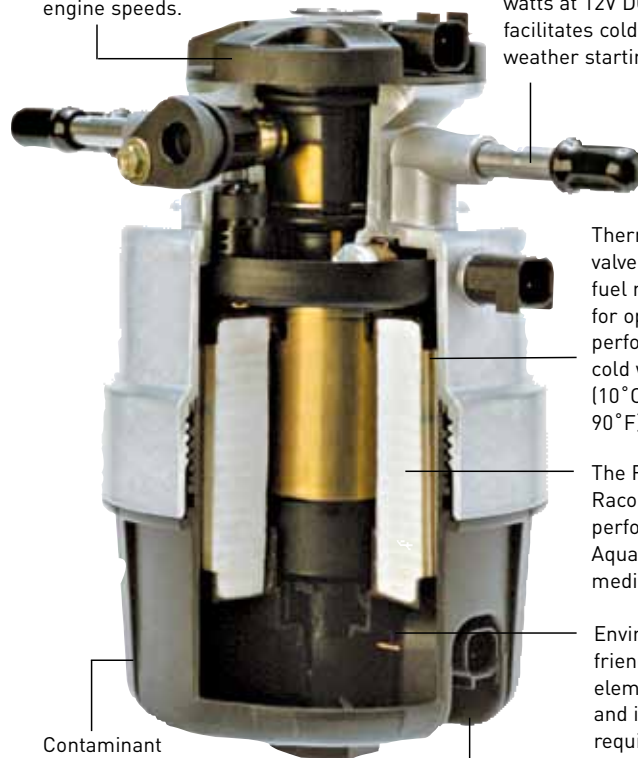

Thermal recirculation valve regulates return fuel recirculation for optimum performance during cold weather operation (10°C / 50°F – 32°C / 90°F).

The RFCM contains Racor's high performance Aquabloc II filter media.

Environmentally friendly cartridge-style element is incinerable and is available at the required efficiency levels for high pressure diesel fuel injection systems. An anti-drainback valve makes element service convenient and clean.

Contaminant collection bowl is removable.

Also available in see-through collection bowl.

Water sensing system alerts the operator when service is required and a self-venting drain valve makes draining quick and easy.

The modular design of the RFCM allows features to be added or removed independent of one another – providing a new level of design flexibility.

The Racor fuel conditioning module is designed and manufactured to provide the highest possible value to the diesel engine, vehicle and equipment. The innovation and modular design of the RFCM incorporates all of the low pressure fuel components required by the latest generation of electronically-controlled fuel injection systems. The consistent pressure and volume delivery of pure fuel under various engine speeds, loads and environmental conditions is absolutely essential to achieve the efficiency levels required in today's engines. The modular design of the RFCM allows features to be added or removed independent of one another – providing a new level of design flexibility.

P Series

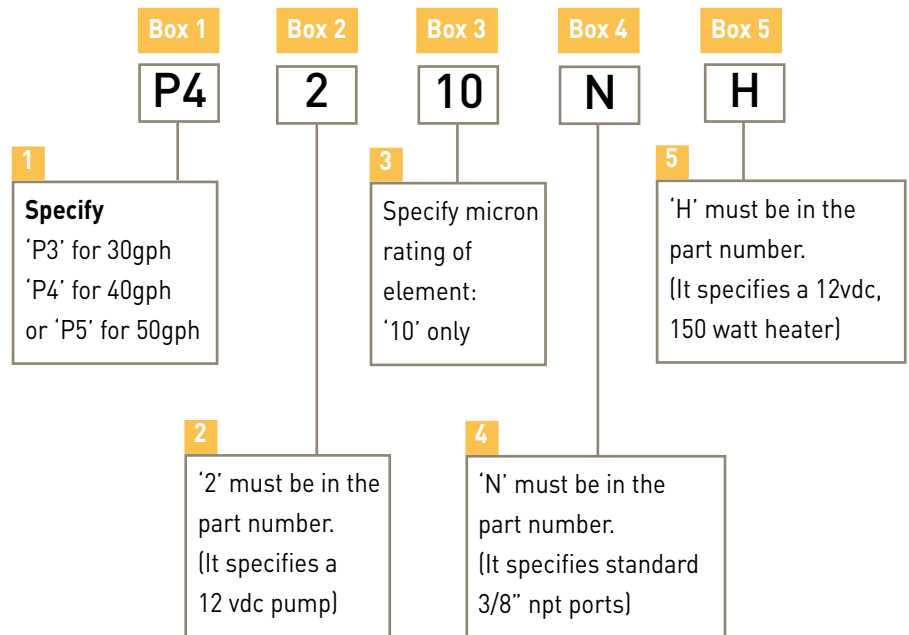

For continuous run pump operation, custom fittings, or pressure requirements consult Parker Filtration +44 (0) 1924 487000.



Model	P3	P4	P5
Maximum Flow Rate	30 gph / 114 lph	40 gph / 170 lph	50 gph / 227 lph
Clean Pressure Drop	0.4 psi / 2.8 kPa	0.5 psi / 3.4 kPa	0.8 psi / 5.5 kPa
Maximum Pump Output (at 14.4 volts)	40 gph / 151 lph	40 gph / 151 lph	40 gph / 151 lph
Standard Fuel Port Size (SAE J476)	3/8" - 18 npt	3/8" - 18 npt	3/8" - 18 npt
Total Number of Ports Available:			
Fuel Inlets	1	1	1
Fuel Outlets	1	1	1
Replacement Elements:			
02 micron	R58060-02	R58095-02	R58039-02
10 micron	R58060-10	R58095-10	R58039-10
30 micron	R58060-30	R58095-30	R58039-30
Minimum Service Clearance	2.5" (28 mm)	2.5" (28 mm)	2.5" (28 mm)
Height	7.7" (196mm)	9.0" (229 mm)	11.5" (292 mm)
Depth	5.2" (132 mm)	5.2" (132 mm)	5.2" (132 mm)
Width	4.8" (122)	4.8" (122 mm)	4.8" (122 mm)
Weight (dry)	3.4 lb (1.5 kg)	3.8 lb (1.7 kg)	4.2 lb (1.9 kg)
Maximum Pump Output Pressure	10 psi (69 kPa)	10 psi (69 kPa)	10 psi (69 kPa)
Features: ¹			
Water Sensor	Standard	Standard	Standard
Heater	Standard	Standard	Standard
Pressure Regulator (10 psi)	Standard	Standard	Standard
Operating Temperature		-40° to +255°F / -40° to +121°C	

Vacuum installations are recommended. ¹Not for use with gasoline applications.

The First in Fuel Filtration

The high grade aluminium components and powder coat paints mean that corrosion is never a worry.

A durable single bolt mounting bracket doubles resistance to vibration fatigue.

Aquabloc media sheds water and keeps engines waterproof, rustproof and dirtproof.

300-watt heaters start you in the cold – thermostats are standard to meet the requirements of today's electronic engines.

Polymer bowl withstands impact and temperature extremes.

Self-venting drain. A single twist makes draining clean, fast and easy.

With an Aquabloc II replacement element, you get a complete kit with all the seals you need.

Aquabloc II media is a blend of high grade cellulose compounded with resins and a special chemical treatment.

Every engine runs better with a system that cleans fuel, removes water, heats fuel and senses when it's time for service. The system is the Racor Turbine Series and it's the most complete, most efficient, most reliable high-capacity engine protection you can install. A system that protects your investment in engines and fuel.



End caps are colour-coded for easy identification and application – red for 30 micron primary filtration, blue for 10 micron primary or secondary, and brown for 2 micron secondary/final filtration.

Use original Racor filter elements to ensure premium performance.

An integral bail handle makes changeouts easy.

Aquabloc II elements filter harmful tiny particles of dirt and algae from fuel. Aquabloc II elements are rustproof – with polymer end caps that won't ever corrode.

Turbine Series

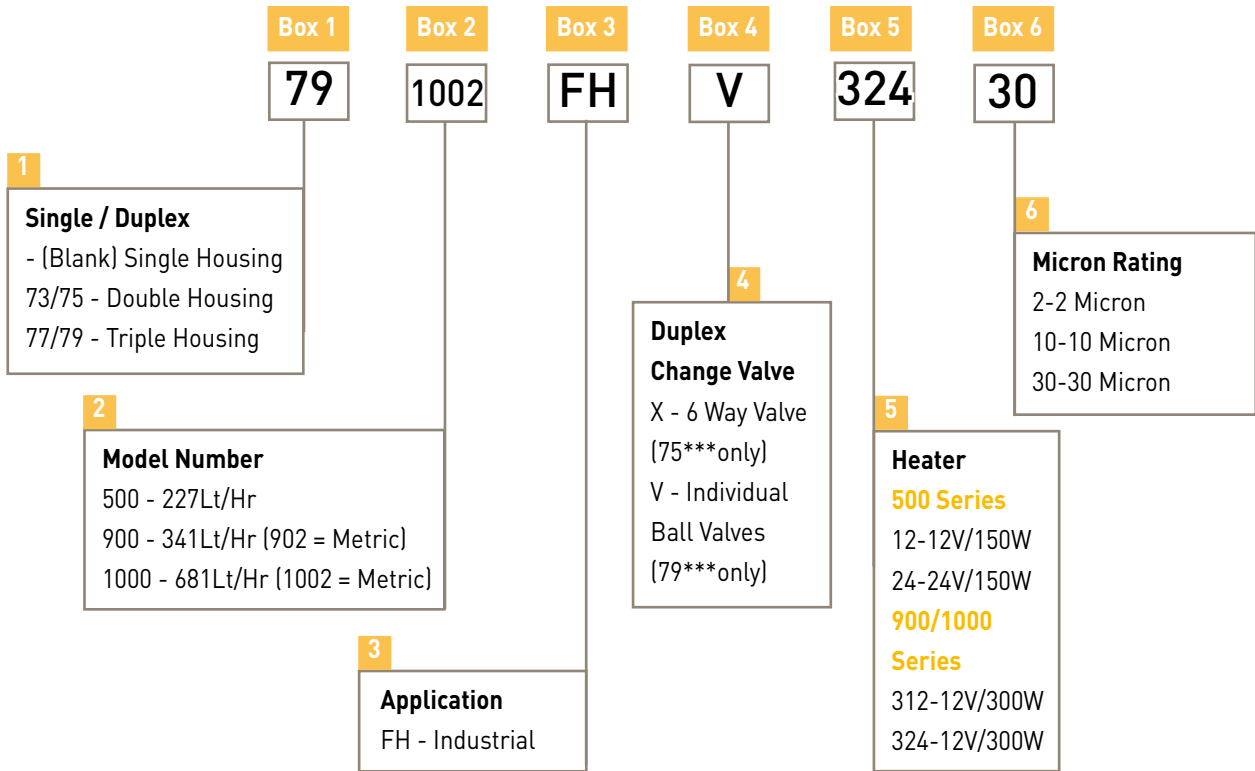

Model	500FG	900FH	1000FH	75500FGX	75900FHX	731000FH	751000FHX	771000FH	791000FHV
Maximum Flow Rate	60 gph / 227 lph	90 gph / 341 lph	180 gph / 681 lph	60/120 gph / 227/454 lph	90/180 gph / 341/681 lph	360 gph / 1363 lph	180/360 gph / 681/1363 lph	540 gph / 2044 lph	360/540 gph / 1363/2044 lph
Height	11.5" / 292mm	17" / 432mm	22" / 559mm	11.5" / 292mm	17" / 432mm	22" / 559mm	22" / 559mm	22" / 559mm	22" / 559mm
Width	5.8" / 147mm	6" / 152mm	6" / 152mm	14.5" / 368mm	18.75" / 476mm	16.5" / 419mm	18.75" / 476mm	21.5" / 546mm	21.5" / 546mm
Depth	4.8" / 122mm	7" / 178mm	7" / 178mm	9.5" / 241mm	11" / 279mm	12" / 305mm	11" / 279mm	12" / 305mm	12" / 305mm
Weight	4 lbs / 1.7 kgs	6 lbs / 2.7 kgs	10 lbs / 4.5 kgs	17 lbs / 7.7 kgs	23 lbs / 10.4 kgs	26 lbs / 11.8 kgs	30 lbs / 13.6 kgs	39 lbs / 17.7 kgs	52 lbs / 23.6 kgs
Port Size Std. (Option)	3/4"-16 UNF / 16mm x 1.5	7/8"-14 UNF / 22mm x 1.5	7/8"-14 UNF / 22mm x 1.5	3/4"-16 UNF	7/8"-14 UNF 1	3/4" NPT	7/8"-14 UNF 1	1"-11 1/2 NPT	3/4" NPT
Clean Pressure	0.25 psi	0.34 psi	0.49 psi	0.70 psi	1.7 psi	1.7 psi	3.7 psi	1.7 psi	2.5 psi
Drop	1.72 kPa	2.4 kPa	3.4 kPa	4.83 kPa	11.7 kPa	11.7 kPa	25.5 kPa	11.7 kPa	17.2 kPa
Maximum Operating Pres.	15 psi / 103 kPa	15 psi / 103 kPa	15 psi / 103 kPa	15 psi / 103 kPa	15 psi / 103 kPa	15 psi / 103 kPa	15 psi / 103 kPa	15 psi / 103 kPa	15 psi / 103 kPa
Replacement Element #	2010PM-OR	2040PM-OR	2020PM-OR	2010PM-OR	2040PM-OR	2020PM-OR	2020PM-OR	2020PM-OR	2020PM-OR+
Element	4" / 102mm	5" / 127mm	10" / 254mm	4" / 102mm	5" / 127mm	10" / 254mm	10" / 254mm	10" / 254mm	10" / 254mm
Removal Clearance									

Notes:
1 Male "JIC" 37" fittings.
2 Flow rates shown for one/both filters on-line.
3 Flow rates shown for two/all filters on-line.
 For accurate fuel flow rates consult your engine manual, engine manufacturer's agent or Racor distributor.

Manifold Units:
 • 75500, 75900 and 751000 double manifolds with shutoff valve.
 • 731000 double manifold without shutoff valves.
 • 791000 triple manifold with shutoff valves.
 • 771000 triple manifold without shutoff valves.

Fuel Filter Primer Pump

Applications

The Turbine Series Fuel Primer Pump Kit is designed for marine, gen set, and mobile applications.

Product

The **RKP1912** (12 volt) and **RKP1924** (24 volt) Fuel Primer Pump Kits can be retrofitted to the Racor 1000 or 900 series fuel filters already in service.

The Primer Pump Kit is designed to offer improved ease of maintenance for the user.

The Primer Pump Kit is a pre-assembled system which includes all the components ready for easy installation. It is manufactured with premium materials installed into a die cast and powder coated housing.

How it works

The Fuel Primer Pump Kit is an innovative and proprietary system consisting of a pre-screen filter, a flow bypass circuit and a roller cell pump powered by a 12VDC brushed motor or a 24VDC brushless motor.

When the switch is activated the fuel is drawn into the pre-screen and then pumped through the housing refilling the unit with fuel. When not in use the primer pump system is bypassed and the Racor fuel filter/water separator functions normally.

The Primer Pump Kit works on Racor duplex and triplex systems also. This will allow one Racor primer pump to prime the other filter or filters in a manifold system such as a 751000MAX for example.

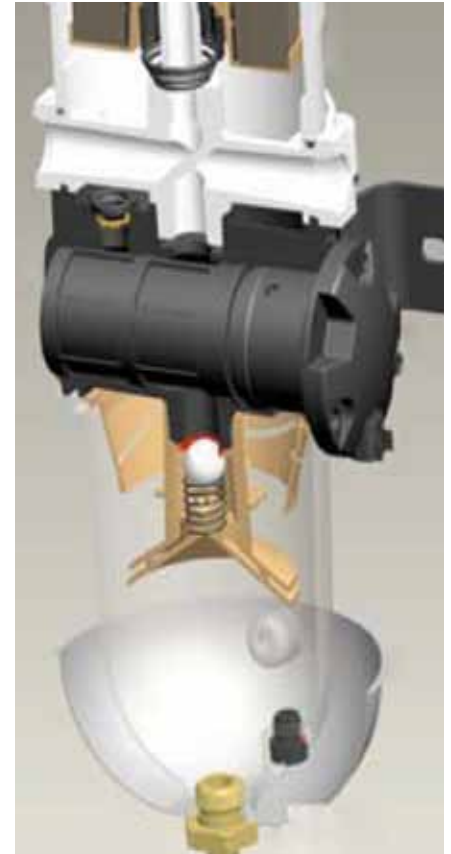

Benefits

- Easy installation.
- Pump adds only 3.3" to the over all assembly.
- 60 gallons per hour flow rate while in priming mode.
- 12 VDC brushed electric motor.
- 24 VDC brushless electric motor.
- 100 micron pre-screen.
- One size fits several models.
- Kit includes wiring harness and controller switch.
- Allows for electric re-priming of filter and fuel system.
- Not for use as continuous duty.



OEM CCV Solutions



Combined CCV
Impactor / Oil
Filler Cap



Whilst Racor's extensive standard CCV range is extremely versatile and robust, offering a solution for almost every diesel application, Racor also endeavour to offer unique innovation OEM solutions. The OEM offering includes rocker cover integration and supply, flange mount integration, fit for life impactor solutions and open breather options. These solutions can offer anything up to 98% efficiency 'depending on customer requirements.'



Hyundai L Series



Case New Holland Intergrated
CCV Rocker Cover

CNG and LPG Filtration

Today's alternative fuels – compressed natural gas, liquid natural gas and liquid propane gas – have the same problems that plague diesel and gasoline... contamination that collects during handling, water that condenses in tanks and compressors that leak oil into the fuel stream.

The precision components necessary for the efficient operation of an alternative fuel system demand superior filtration.

The solution – the industry's first and most complete line of alternative fuel filter/coalescers and prefilter/strainers. From pipeline to engine – Racor fuel filter/coalescer products provide the ultra-fine filtration required by alternative fuels.

Protecting the fuel injectors and components of an alternative fuel system is vital to efficient vehicle operation. Racor offers the most complete line of fuel filter/coalescers and prefilter/strainers for on-vehicle applications. These filters ensure removal of damaging aerosol contamination as small as 0.3 to 0.6 micron and exceed 95% efficiency, depending on the grade of element specified. Units are available in a range of pressure ratings and are constructed of aluminium, stainless steel or painted steel.

The fuel filter/coalescer elements are produced by a process of arranging microglass fibres into a tubular form. During operation, fuel is forced through the coalescing media from the inside of the cartridge through the tubular wall to the outside, where the large droplets fall to the bottom of the housing.

Oily water emulsion accumulates until drained while the dirt particles remain trapped on the surface of the fibres.



Prefilter/Strainers

Engineered and precisely manufactured to provide superior performance at operating pressures up to 500 psi, the compact, in-line prefilter/strainers are an essential first step in a complete filtration system.

Low Pressure Fuel Filter/Coalescers

Low pressure coalescers are ideal for operating environments up to 54 bar. All aerosol contaminants in the 0.3 to 0.6 micron range are filtered to an efficiency level that exceeds 95%.

High Pressure Fuel Filter/Coalescers

These coalescing filters are constructed to withstand operating pressures to 245 bar. These coalescing filters remove over 95% of aerosols in the 0.3 to 0.6 micron range.

Engineered Modules/System

The combination of high pressure filters, regulators, fittings and brackets into one module allows manufacturers to specify one part number.

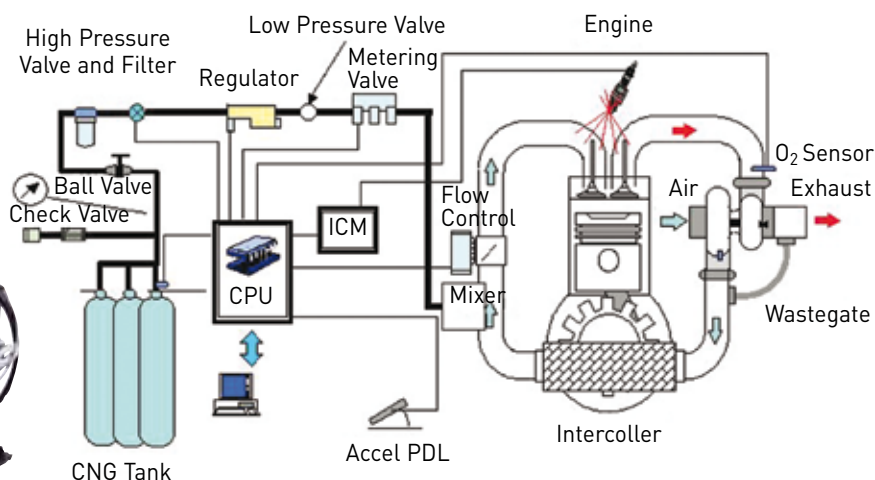
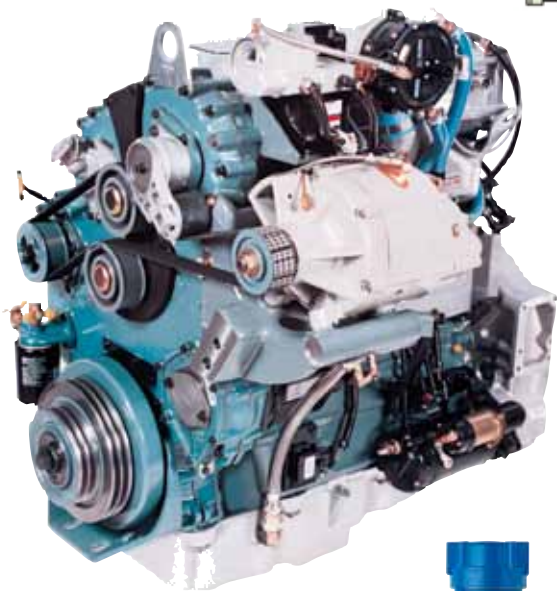

Ordering and Specification

Contact your Parker Specialist for details



	LOW		MEDIUM	HIGH		
Model	FFC-119	FFC-110	FFC-110L	FFC-116	FFC-112	FFC-113
Type	Pre-filter/ Strainer 1	Coalescer 3	Coalescer	Coalescer 3	Coalescer	Coalescer
Port	5/8" Outlet 1/4" Inlet	1/4" NPT	1/2" NPT	1/4" NPT	1/2" NPT 9/16 SAE	1/4" NPT
Bar (Max.)	34 bar	54 bar	54 bar	245bar	245 bar	245bar
Rated Flow 2	25	25	50	15	50	8.4
Length (in / mm)	4.87" / 123.69 mm	7.16" / 181.86 mm	10.4" / 264.16 mm	4.75" / 120.65 mm	8.03" / 203.96 mm	3.85" / 97.79 mm
Diameter (in / mm)	2.63" / 66.80 mm	3.13" / 79.50 mm	3.13" / 79.50 mm	2.25" / 57.15 mm	2.97" / 75.43 mm	1.75" / 44.45 mm
CNG		•	•	•	•	•
LPG	•					
Weight lbs. / kg	.5 lbs / .23 kg	1.5 lbs / .68 kg	1.8 lbs / .82 kg	1.5 lbs / 0.68 kg	5.5 lbs / 2.49 kg	1.75 lbs / .79 kg
Element	N/A	CLS110-10	CLS110-10L	CLS112-10	CLS113-6	CLS116-10
Number						
Sump	N/A	5.0	4.7	0.5	5.0	0.25
Capacity Oz.						
Material	Painted Steel	Painted Aluminium	Painted Aluminium	Stainless Steel	Anodized Aluminium	Stainless Steel

Notes: **1** Use in conjunction with coalescer.

2 SCFM at 100 PSIG.

3 ECER 110 versions of FFC-112 and FFC-110 available on request.

FBO Filter Assembly

Racors' new FBO-10 and FBO-14 filter assemblies are designed to meet the toughest hydrocarbon refuelling conditions and provide for ease of filter change outs. The FBO Assembly can flow at 25gpm (95 lpm) or up to 75gpm (230 lpm) depending on the model, the elements installed and fuel being filtered.

The FBO assembly can be used on mobile refuellers or installed in refuelling cabinets. The unit can also be used for diesel fuel dispensing pumps or as a primary fuel filter/water separator for large diesel engines.

The assembly features a locking ring collar, which attaches the filter housing to the aluminium die-cast filter head with four bolts. The slotted locking ring collar allows maintenance personnel to hand-loosen the four collar bolts, rotate and lower the bowl assembly for element change outs. With new element installed, simply raise the bowl and rotate into position on the locking ring and hand-tighten evenly.

The closure hardware consists of stainless steel nuts, bolts and washers with metal hand knobs for ease of maintenance – one person can easily change the filter element. No special tools are required.

The versatile FBO-10 and the FBO-14 filter assemblies have three element options to meet most field applications.

For refuelling applications the filter separator element is used. The filter separator element removes contaminants and water from jet fuel, aviation gas, diesel fuel, gasoline and hydrocarbon fuels.

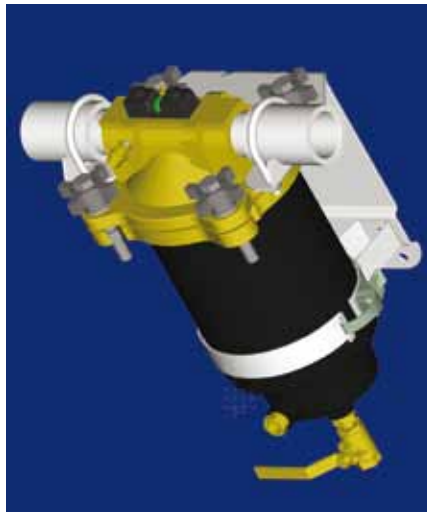

Standard Design Features

- Die-cast aluminium head
- Steel filter bowl assembly
- Powder coated components
- Locking ring collar, no clamps
- 1 1/2" NPT Inlet and Outlet
- 10 bar @ 240° F max. design pressure
- Manual drain valve
- Manual vent valve

Options

- Mounting bracket
- Sight level gauge
- Pressure diff. indicator

Installations

- Aviation fuel trucks
- Aviation fuelling cabinets
- Diesel fuel dispensing system
- Marine fuel docks
- Fuel systems on large diesel engines

Applications

- Jet fuel, aviation gas, diesel fuel, gasoline, kerosene, JP4, JP5 and JP8.

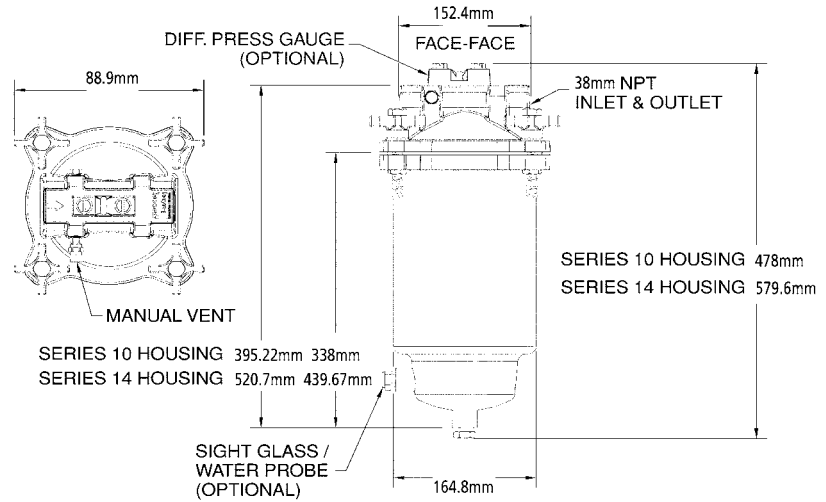

Element Applications

Application	Micron Rating	FBO-10 Element	FBO-14 Element
Filter Separator	1	FBO 60327	FBO 60336
	5	FBO 60328	FBO 60337
	10	FBO 60353	FBO 60356
	25	FBO 60329	FBO 60338
Micro Filter	1	FBO 60330	FBO 60339
	5	FBO 60331	FBO 60340
	10	FBO 60354	FBO 60357
	25	FBO 60332	FBO 60341
Absorptive Filter	1	FBO 60333	FBO 60342
	5	FBO 60334	FBO 60343
	10	FBO 60355	FBO 60358
	25	FBO 60335	FBO 60344



Performance Specifications

FBO-10	Maximum Flow Rates			Clean	Change
	Diesel	Gasoline	Kerosene	Delta P	Delta P
Microfilter	18 GPM (68 LPM)	52.5 GPM (199 LPM)	35 GPM (132 LPM)	< 2 PSID	15 PSID
Filter Separator/ Absorptive	10 GPM (38 LPM)	31.5 GPM (119 LPM)	21 GPM (79 LPM)	< 2 PSID	15 PSID
FBO-14	Diesel	Gasoline	Kerosene	Delta P	Delta P
Microfilter	25 GPM (95 LPM)	75 GPM (284 LPM)	50 GPM (189 LPM)	< 2 PSID	15 PSID
Filter Separator/ Absorptive	15 GPM (57 LPM)	45 GPM (170 LPM)	30 GPM (114 LPM)	< 2 PSID	15 PSID

RVFS Series

The Racor RVFS Series filter vessels offer an unparalleled high efficiency, versatile, economical and low maintenance solution to many fuel delivery and industrial filtration applications. The vessels will accept Micro-filter pre-filters, Coalescer/ Water Separator combinations, Monitor/Absorbers and clay treatment bags.

Used mainly in the diesel and kerosene re-fuelling industry, these robust vessels can be seen on countless forecourts providing clean dry safe fuel to modern TDI, PD, HDI, CDI and heavy duty vehicles. Equally these vessels can be used for kerosene, aviation fuels, heating oils, gasoline and numerous other industrial fluids and fuels.

RVFS Element Options

Coalescer / Separator

Coalescer and separator mounted in the RVFS housing. Fluid/fuel is passed from the outside of the coalescer to the inside. The coalescer element provides primary filtration of the fuel as well as coalescing free water from it. The clean fuel passes through the separator barrier and into the outlet of the housing. The coalesced water droplets are repelled by the hydrophobic barrier and are collected in the sump of the housing. The sump should be drained routinely.

FP Element Installation

Mounting shown – Parker's cellulose FP microfilter series. These elements offer 95% filtration efficiency of fluids and are available in micron ratings of 1, 2, 5, 10, 25 & 40.

When ordering a RVFS for FP installation the kit number 72137 is required.

The RVFS-1, 2 & 3 housing series is compatible with all 6-7" OD, 3.5" ID in multiple lengths of 14 inches.

FW Element Installation

Mounting shown – Parker's combination water absorbing/ filtration FW filter series. These elements will absorb free water from fuels to less than 15 ppm and offer 95% filtration efficiency and are available in micron ratings of 1, 5, 10 & 25. This product can also be used to absorb free water and filter industrial oils.

When ordering a RVFS for FW installation the kit number 72137 is required. The RVFS-1, 2, 3 housing series is compatible with all 6-7"OD, 3.5"ID elements in multiple lengths of 14 inches.



Optional Accessories

- Automatic air eliminator
- Pressure relief valve
- Differential pressure gauge
- Liquid level gauge
- Manual water drain valve
- Support stand
- Wall mount brackets

Applications

- Jet A, Jet A1
- JP4, JP5, JP8
- Diesel Fuel
- Kerosene
- Gasoline

Features

- Carbon steel construction, other materials available
- 17 23 ASME code Section VIII construction, stamped and certified. CE certified vessels available.
- Zinc plated swing bolt closure.
- Buna-N o-ring cover seal
- Interior epoxy coated MIL C4556E, exterior primer coated (carbon steel versions only)

Connections

- Inlet and Outlet: 2 inch NPT
- Main Drain and Liquid Level Ports: 1/2 inch NPT
- Vent and Pressure Relief Connection: 3/4 inch NPT
- Differential Pressure Gauge/ Sample Ports: 1/8 inch NPT



Vessel and Element Sizing Specification



RVFS Maximum Flow Rates

Flow rate with 8 cSt
Diesel GPM

Flow rate with 7 cSt Aviation Fuel
GPM

Vessel	Coalescer	Prefilter	Monitor	Coalescer	Prefilter	Monitor	Clay
RVFS-1	25	66	29	50	66	58	N/A
RVFS-2	50	133	58	100	133	116	7
RVFS-3	75	200	87	150	200	174	14

Note: ASME or CE rated vessels available. EU legislation requires CE marked vessels on all European installations.

Element Options

Coalescer Element Prefix OCP

Separator Element Options

Vessel	1 micron	2 micron	5 micron	10 micron	25 micron	5 micron	10 micron	25 micron	Teflon
RVFS-1	OCP-15854	OCP-15855	OCP-15858	OCP-15868	OCP-15878	SP-15404	SP-15405	SP-15407	ST-15401
RVFS-2	OCP-30854	OCP-30855	OCP-30858	OCP-30868	OCP-30878	SP-30404	SP-30405	SP-30407	ST-30401
RVFS-3	OCP-44854	OCP-44855	OCP-44858	OCP-44868	OCP-44878	SP-44404	SP-44405	SP-44407	ST-44401

Water Absorbing FW Elements

Clay Canister

Vessel	1 micron	5 micron	10 micron	25 micron	Clay	
RVFS-1*	FW-61401	FW-61405	FW-61410	FW-61425	FCC-18701	*Note RVFS 1 takes one element, RVFS 2 takes 2 elements, RVFS 3 takes 3 elements.
RVFS-2*	FW-61401	FW-61405	FW-61410	FW-61425	FCC-18701	
RVFS-3*	FW-61401	FW-61405	FW-61410	FW-61425	FCC-18701	

FP Silicon Treated Pre-filters

Vessel	0.5 micron	1 micron	2 micron	5 micron	10 micron	25 micron	
RVFS-1	FP-14601-1/2	FP-14601	FP-14602	FP-14604	FP-14605	FP-14607	Recommended options for diesel fuel applications. Consult Racor for other fluids.
RVFS-2	FP-30601-1/2	FP-30601	FP-30602	FP-30604	FP-30605	FP-30607	
RVFS-3	FP-44601-1/2	FP-44601	FP-44602	FP-44604	FP-44605	FP-44607	

Vessel Dimensions (mm)

height	width	depth	dry weight	overhead space requirements
991	349	343	46 kg	406
1295	349	343	52 kg	813
1651	349	343	59 kg	1194

For additional information please consult Parker Racor for installation details.

Closed Crank Case Ventilation Systems

The problem – open and unfiltered engine crankcase breathers, allow oil and soot laden aerosol mist to enter the atmosphere from the crankcase.

Environmental concerns and EPA and European legislation bans the emission of open and untreated crankcase gases into the atmosphere. To reduce total engine emissions, it is becoming necessary to close the crankcase breather system, by routing these gases back into the air intake system.

Crankcase blowby is produced when combustion gases under high pressure are blown past the piston rings into the crankcase. As these blow by gases pass through the crankcase, they become contaminated with oil mist.

Racor's crankcase ventilation system removes these contaminations. The exhaust can then be allowed to be vented in the atmosphere.

For applications requiring more stringent emissions requirements, a closed crankcase filter is recommended.

In this application, the exhaust from the crankcase filter is routed to the inlet side of the turbo. A regulator in the crankcase filter controls the vacuum in the crankcase to ensure proper operation.

Pictures below: (left) Cummins QSM11 marine engine with CCV cutaway. (right) Caterpillar 3196 marine engine with Racor CCV/AF System.



A modern diesel engine schematic

A schematic indicating air intake filtration, crankcase ventilation and water separation and fuel filtration in a modern diesel engine.

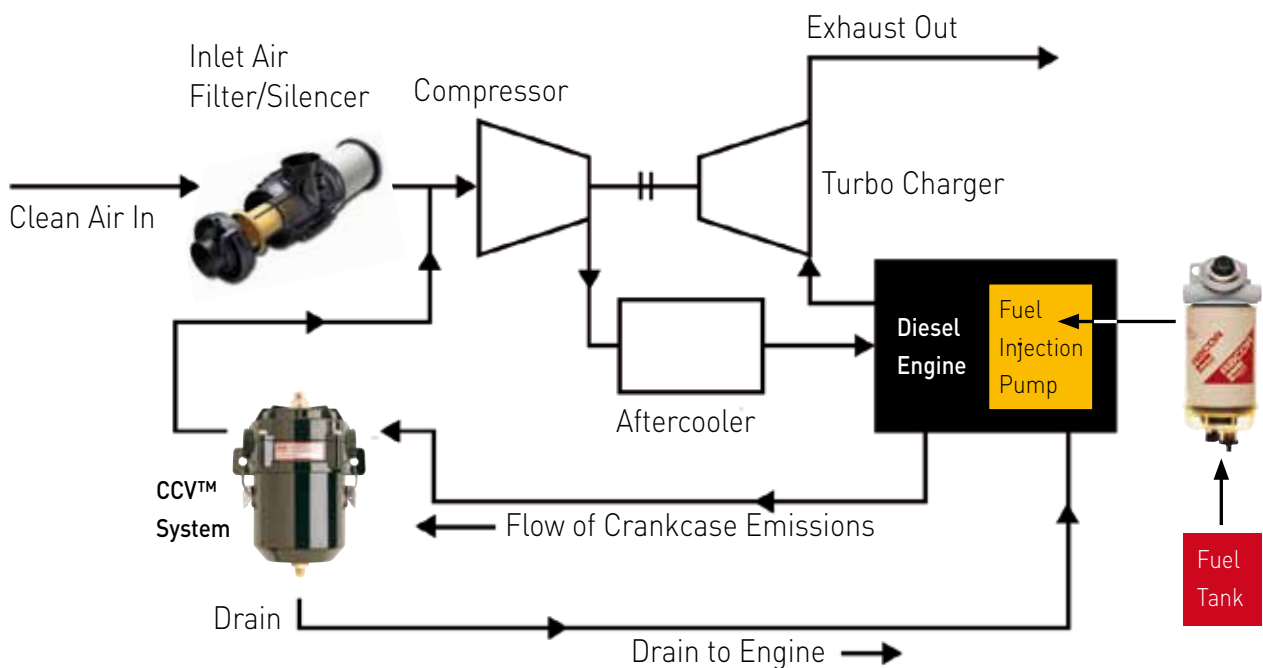

- In closed environments like generator set and marine engine rooms, damage to surrounding equipment such as radiators and electronic control panels can cause hazardous conditions, down time and expensive maintenance.
- Oil mist will coat and contaminate the aftercooler and other engine components. This coating reduces engine cooling capacity, causes a degradation of engine performance and reliability over time, and shortens the useful service life of the engine components.
- The engine intake inhales contaminated gasses, clogging air filter systems and damaging turbo-charger components. It is imperative that oil mist be removed from the crankcase emissions prior to introduction into the engine air intake in closed breather systems.

Unique crankcase pressure regulator with integral bypass valve that minimizes variation in crankcase pressure. Excessive variation in crankcase pressure can damage seals, cause loss of oil and other problems

Pop-up style indicator that alerts of a bypass condition and the need for a filter change

High efficiency oil separation to 0.3µ (microns)

Durable glass-filled nylon components

Replaceable high-performance filter with depth-loading, micro-glass fiber coalescing media

Maximum continuous operating temperature, -40°F to +240°F (-40°C to 116°C)



Left or right hand inlet/outlet options

Stainless steel latches for tool-less element change

Extended filter service interval from the Vaporbloc™ element

Steel with epoxy powder coating

Drain check valve allows collected oil to be returned to the crankcase. This eliminates frequent draining and significantly reduces oil consumption

Separator Performance Data

Measurement of blow-by aerosol size distribution shows that over 90% of oil particles can be < 1 micron in diameter. Typically a significant peak occurs in particle sizes

between 0.4 and 0.5 microns. (as shown below). While some other CCV systems can offer reasonable efficiency above 1 micron, depth filtering media gives

excellent sub micron performance, while still maintaining a very low pressure differential across the entire engine speed and load range.

Typical Engine Blow-by Oil Particle Size Distribution

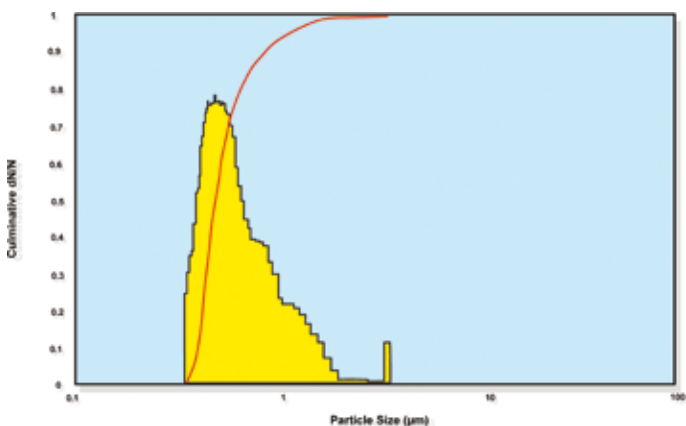

Racor CCV Media Fractional Efficiency Curve

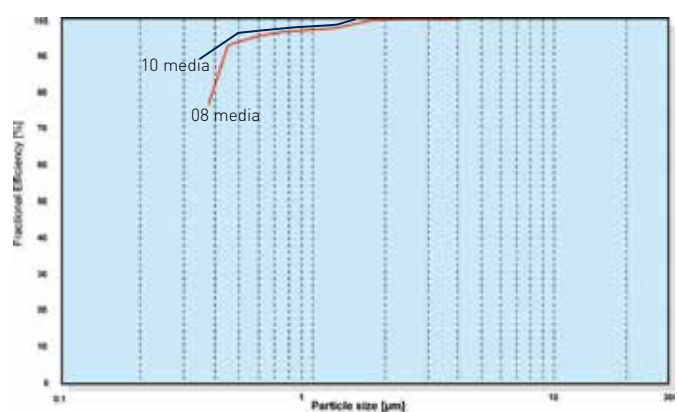

Advanced Crankcase Pressure Regulation

Racor CCV s employ a unique upstream pressure regulation system, which is the only way to maintain consistent crankcase pressures across the full engine speed/load range and throughout the filter element service life.

Competitive products are forced to use vacuum limiter forms of regulation which allow varying crankcase pressures at different engine speeds and are unable to regulate for increasing filter element differential during the service period.

Racor CCV Crankcase Regulation

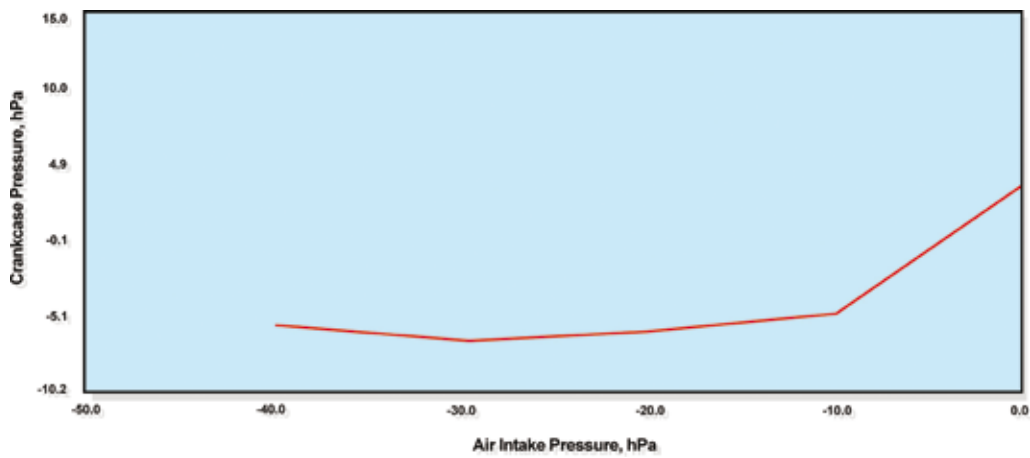

Racor CCV Sizing

CCV systems should be specified using engine blow-by flow, based on engine manufacturer's data. The chart will help you to easily select a CCV, which will allow for a typical filter element service period of 750 hours, for larger applications it is possible to use multiple CCVs, for convenience the CCVs can be specified with Right or Left hand inlet (Suffix R or L).



Ordering and Specification

Model

Height
Maximum Opening Width (incl. clamps & bracket)
Depth
Weight
Filter Removal Clearance
Replacement Element High Efficiency Media
Replacement Element Ultra Efficiency Media
Housing Material

Inlet & Outlet Thread Size
Flow Max. Cubic Feet per Minute
Crankcase Pressure Regulator
Bypass/Change Indicator
Engine Block Check Valve Return Fitting
Swivel Fitting (Qty.)
Oil drain hose I.D.



Crankcase Replacement Elements

Open System Crankcase Filtration

Crankvent CV4500, CV6000 and CV8000 Systems trap crankcase blow-by and recycle engine oil through a high performance filter. They help to decrease costs for maintaining air filters and keeping engine rooms clean. These units are typically used as an "open" system for non-turbocharged engines.



CCV4500	CCV6000	CCV8000	CCV12000
9.25" / 235.0 mm	12.00" / 304.8 mm	13.88" / 352.6 mm	18" / 457 mm
7.50" / 190.5 mm	11.25" / 286.8 mm	13.25" / 336.6 mm	17.88" / 454.2 mm
5.60" / 142.2 mm	7.30" / 185.4 mm	9.30" / 236.2 mm	9.30" / 236.2 mm
3.26" lbs / 1.48 kg	5.0"1 lbs / 2.28 kg	8.72 lbs / 3.96 kg	9.5 lbs / 4.30 kg
2.25" / 57.2 mm	4.00" / 101.6 mm	5.00" / 127.0 mm	9.00" / 229 mm
CCV 55248-08	CCV 55274-08	CCV 55222-08	CCV 55222-12-08
CCV 55248-10	CCV 55274-10	CCV 55222-10	CCV 55222-12-10
Die cast head, glass-filled nylon and black powder epoxy-coated steel bowl.	Die cast head, glass-filled nylon and black powder epoxy-coated steel bowl.	Die cast head, glass-filled nylon and black powder epoxy-coated steel bowl.	Die cast head, glass-filled nylon and black powder epoxy-coated steel bowl.
1 3/16" - 12 STOR	1 5/8" - 12 STOR	1 7/8" - 12 STOR	1 7/8" - 12 STOR
10 cfm / 283 lpm	20 cfm / 566 lpm	40 cfm / 1132 lpm	50 cfm / 1415 lpm
Integral	Integral	Integral	Integral
Integral or Remote	Integral or Remote	Integral or Remote	Integral or Remote
1/4 NPT"	1/4 NPT"	3/8 NPT"	3/8 NPT"
# 6 JIC (2pcs.)	# 6 JIC (2pcs.)	# 8 JIC (2pcs.)	# 8 JIC (2pcs.)
.375"	.375"	.5"	.5"

* Units can be manifolded to handle higher flow rates.

Air Filtrations Solutions in every day situations

The **ECO III** is Racor's newest filter model, designed specifically to be the most versatile filter on the market, allowing for multiple inlet/outlet angle positions, left or right hand element removal and outlet configurations, with CCV and gauge connections built in. Designed for 250-500HP engines the ECO III's versatility makes it ideally suited for truck, bus and coach applications.



ECO III in a typical Closed Air Filtration System Configuration



ECO III Pressure Drop

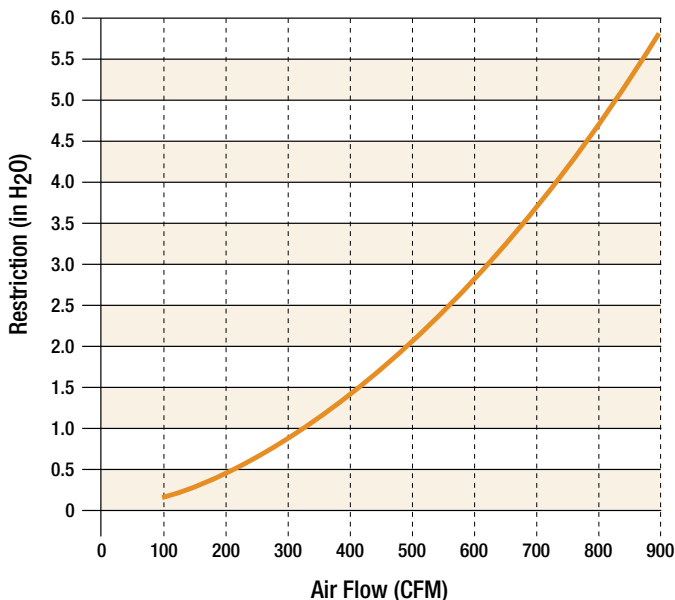

Part No.	Description
----------	-------------

Housing

- 500250012 Housing, Base with Secondary
- 500251012 Housing, Base without Secondary

Service Elements

- 500247012 Primary Element
- 500233000 Safety Element

Replacement Parts

- 500187012 Base
- 5002192012 Outlet Pan
- 500229000 Clip (8 per package)

For additional information regarding custom manufacturing and ECO III configurations for larger horsepower ratings, please contact Racor Division.



The Racor Pamic Range

is uniquely adaptable, providing both lower maintenance costs and increased filtration efficiency to extend engine life cycles even in the harshest, most aggressive operational environments.



The ECO II is a lightweight, compact easy fit, economical air cleaner offering maximum efficiency for light to medium duty applications. The ECO II can also be rotated to position the air intake at any angle. It also has a water resisitant paper, which gives engine protection in moisture laden environments.

The AF Series Filters and Pre-Cleaners

are designed to be connected to the air intake of gasoline or diesel engines. A full range of complete air cleaners, pre-cleaners and combination air/pre-cleaner units are available for engines from 30 to 600HP.



Water Probe Kits

Racor offers a wide selection of water probes, each designed for use with particular models and installation requirements. These probes are available in various configurations to fit every Racor filter/separator. The water probe is only a component in the water detection system and will not work without a Racor electronic detection module (see next two pages). The RK30880 has the electronic detection module built-in to its design and has the simplest installation procedure. Multiplex units must use one probe for each collection bowl but only one water detection module is needed.



Specifications	RK 21069	RK 30964	RK 22371	RK 30880
Threads	1/2" -20 Threads	1/2" -20 Threads	9/16" -18 Threads	1/2" -20 Threads
Description	One piece design with two wires. Requires a detection module.	Includes detachable 2-wire connector. Requires a detection module.	Includes detachable 2-wire connector. Requires a detection module.	Active probe, 3-wire connector, no detection module.
Voltage	12 or 24 vdc	12 or 24 vdc	12 or 24 vdc	12 or 24 vdc
Power Draw: (12 volt) (24 volt)	N/A	N/A	N/A	5 Milliamps 10 Milliamps
Maximum Load	N/A	N/A	N/A	1 Amp
Weight	0.03 lb (0.01 kg)	0.02 lb (0.01 kg)	0.1 lb (0.05 kg)	0.4 lb (0.2 kg)

Caution: Never wire a water probe directly to voltage or another brand of detection module.

T-handle Vacuum Gauge

T-handle vacuum gauges are available to monitor element condition and as the filter element slowly becomes clogged with contaminates the restriction (resistance to flow) increases. The fuel pump still tries to draw fuel (suction) but because of this restriction less fuel is delivered to the engine and instead more air is pulled from it (fuel de-gassing). These results can cause the engine to lose power and eventually stall. By installing a vacuum gauge in your fuel system (at the outlet side of the Racor filter) visual monitoring of element condition is possible at a glance. At the first indication of decreased performance, note the dial reading or apply the 'red line' decal provided with most kits. This will assist in knowing when to change the filter at the next interval. T-handle Vacuum Gauge.



Specifications	RK11-1969	RK11-1669
Description	500FG units only. T-handle vacuum gauge kit includes gauge & fitting with 9/16" -18 UNF threads. See below.	For 900FH &1000FH units only. T-handle vacuum gauge kit includes gauge & fitting with 9/16" -18 UNF threads. See below.
Threads	1/4" NPT bottom boss mount.	1/4" NPT bottom boss mount.
Dimensions	2.0" W x 1.1" D	2.0" W x 1.1" D
Dial	2 in.	2 in.
Weight	0.3 lb (0.1 kg)	0.3 lb (0.1 kg)

Special Notes: For severe vibration applications, mount the gauge on a stable, remote location and connect to the source using flexible tubing. After September 1999, Racor converted many liquid-filled gauges to new silicone dampened movement. This new (dry) technology provides a vibration resistant design that never leaks fluid or requires adjustments due to temperature or altitude variations.

Water Detection Modules

Racor Water Detection Kits are available in a wide selection for various installation requirements. Under dash, in-dash and remote mount, these solid-state units may be used with any Racor fuel filter/water separator and water probe. They are manufactured using the highest quality materials and are all 100% electrically tested. An electric detection module analyzes electrical resistance at the water probe and determines if water is present. If so, the detection module operates to indicate water, based on its features listed below. All units reset automatically after water is removed (unless specified).



Specifications	RK 20726	RK 11-11570	RK 20725	RK 20725-24
Voltage	12 or 24 vdc	12 or 24 vdc	12 vdc	24 vdc
Features	Light & Buzzer	Light & Buzzer	Light Only	Light Only
Description	Red DRAIN lamp illuminates continuously and buzzer sounds momentarily when water is detected. Power-up self diagnosis feature and circuit protection included.	Includes pre-set vacuum switch (7in.Hg.), connector and outlet adapter fitting. The red DRAIN or CHANGE FILTER lamps illuminate continuously and buzzer sounds momentarily when water is detected.	Green ON lamp illuminates with power and red DRAIN lamp illuminates when water is detected. Includes initial power-up self diagnosis feature & circuit protection.	Same as RK20725
Dimensions ¹	2.2" Diameter x 3.2" Depth	2.2" Diameter x 2.0" Depth	1.0" H x 1.5"D x 2.0" W	1.0" H x 1.5"D x 2.0" W
Power Draw: (12 volt) (24 volt)	3 Milliamps 13 Milliamps	3 Milliamps 14 Milliamps	10 Milliamps	10 Milliamps
Max. Internal Load	30 Milliamps	30 Milliamps	30 Milliamps	30 Milliamps
Weight	0.4 lb (0.2 kg)	0.9 lb (0.4 kg)	0.4 lb (0.2 kg)	0.4 lb (0.2 kg)

¹Cut 2.0" diameter hole to mount gauges in instrument panel.

RK22628 Bowl Wrench

Racor offers a hand wrench to remove all metal and see-through spin-on bowls that feature external ribs. By simply fitting the wrench over the bowl ribs, the bowl can be removed from the replaceable spin-on element, or filter housing with little effort. The wrench is made of a corrosion proof, high-impact, high-strength engineered polymer. One bowl wrench per kit.



Primary (Pre-) Fuel/Water Separator For Vacuum Applications And Final Fuel For Pressure Applications

Fuel is drawn out of the fuel reservoir by the lift pump into and out of the pre-fuel filter/water separator. The fuel is pre-filtered through a 10 to 30 micron rated filter which also removes harmful water, thereby protecting the lift pump and injection system. The lift pump pressurizes the pre-filtered fuel into the final filter. Fuel is then filtered by a 1 to 7 micron rated filter, ensuring purified fuel is delivered. The combination filtration system design provides superior protection for heavy-duty applications where high levels of contamination and high volumes of fuel require a high filter capacity. Fuel conditioning options (drain, water sensor, hand primer pump, heater, etc.) are usually installed in the primary assembly.

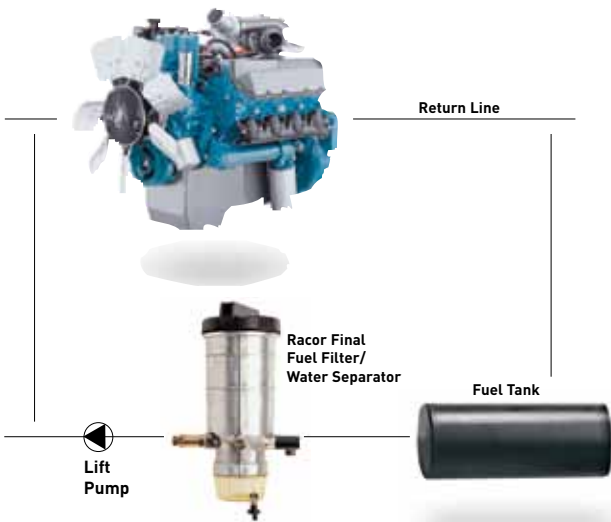
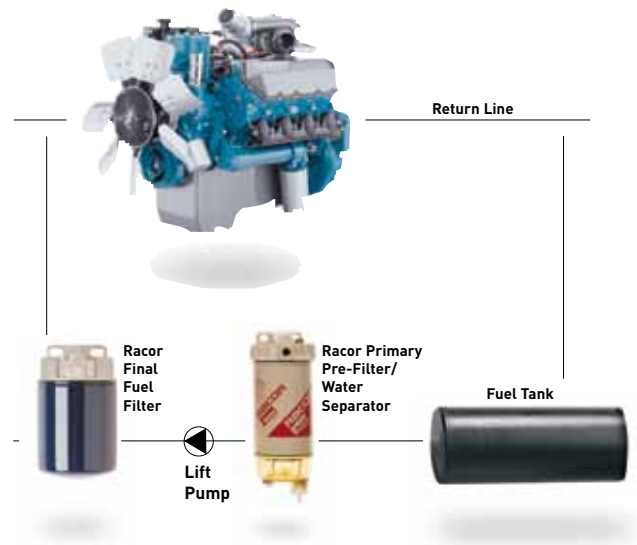

Secondary (Final) Fuel Filter/Water Separators For Vacuum Applications

This design integrates the primary fuel filter/water separator and final fuel filter into one system that is installed prior to the lift pump. The single assembly provides total filtration (1 to 7 microns) and water separation for the entire fuel system. This filtration system design provides excellent protection for applications where cost and service constraints are a challenge. Sufficient space for an adequate size combination unit must be available.

Secondary (Final) Fuel Filter/Water Separators For Pressure Applications

This design integrates the primary fuel filter/water separator and final fuel filter into one compact system that is installed after the lift pump. Generally, an in-fuel reservoir filter screen (100 to 200 micron) is utilized to complete the filtration system. The final fuel filter/water separator is installed after the lift pump and provides protection (1 to 7 microns) to the high pressure injection system. This filtration system design provides economical fuel injection system protection for small diesel engines, automotive and light-truck applications that already have generally good fuel quality and a relatively low volume of fuel usage.

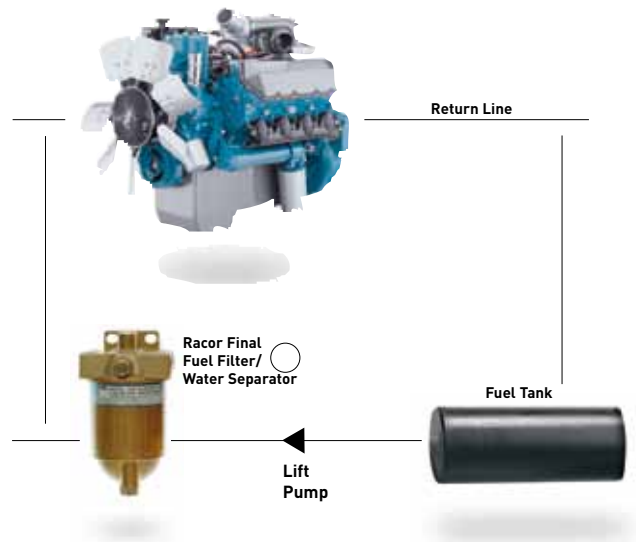

Hydrocarbon Filters



Hydrocarbon filter vessels and elements represent an important and fast developing part of the Parker Racor range. Installation applications include aviation fuel trucks, diesel fuel dispensing systems; marine fuel docks, bulk fuel storage and garage pump dispensing systems.

245R



TC35-01



110A



TC180-01



460R



Hydraulic Filtration



Parker Filtration's global reputation as a reliable supplier of superior hydraulic and lubrication filtration products, quality environmental filter media and fluid power products, is the result of a focused and integrated development and advanced manufacturing systems.

BC45-01



SE50-01



SE60-01



SE90-01



Condition Monitoring



To clearly identify the condition of a fluid system, Parker Filtration has a range of fluid contamination monitoring products. Portable or installed monitors and detectors allow for the observation of fluid within the working system in most circumstances, environments and including hazardous or explosive areas requiring ATEX approved equipment.

Parker Worldwide

Europe, Middle East, Africa

AE – United Arab Emirates, Dubai
Tel: +971 4 8127100
parker.me@parker.com

AT – Austria, Wiener Neustadt
Tel: +43 (0)2622 23501-0
parker.austria@parker.com

AT – Eastern Europe, Wiener Neustadt
Tel: +43 (0)2622 23501 900
parker.easteurope@parker.com

AZ – Azerbaijan, Baku
Tel: +994 50 2233 458
parker.azerbaijan@parker.com

BE/LU – Belgium, Nivelles
Tel: +32 (0)67 280 900
parker.belgium@parker.com

BY – Belarus, Minsk
Tel: +375 17 209 9399
parker.belarus@parker.com

CH – Switzerland, Etoy
Tel: +41 (0)21 821 87 00
parker.switzerland@parker.com

CZ – Czech Republic, Klecany
Tel: +420 284 083 111
parker.czechrepublic@parker.com

DE – Germany, Kaarst
Tel: +49 (0)2131 4016 0
parker.germany@parker.com

DK – Denmark, Ballerup
Tel: +45 43 56 04 00
parker.denmark@parker.com

ES – Spain, Madrid
Tel: +34 902 330 001
parker.spain@parker.com

FI – Finland, Vantaa
Tel: +358 (0)20 753 2500
parker.finland@parker.com

FR – France, Contamine s/Arve
Tel: +33 (0)4 50 25 80 25
parker.france@parker.com

GR – Greece, Athens
Tel: +30 210 933 6450
parker.greece@parker.com

HU – Hungary, Budapest
Tel: +36 1 220 4155
parker.hungary@parker.com

IE – Ireland, Dublin
Tel: +353 (0)1 466 6370
parker.ireland@parker.com

IT – Italy, Corsico (MI)
Tel: +39 02 45 19 21
parker.italy@parker.com

KZ – Kazakhstan, Almaty
Tel: +7 7272 505 800
parker.easteurope@parker.com

NL – The Netherlands, Oldenzaal
Tel: +31 (0)541 585 000
parker.nl@parker.com

NO – Norway, Asker
Tel: +47 66 75 34 00
parker.norway@parker.com

PL – Poland, Warsaw
Tel: +48 (0)22 573 24 00
parker.poland@parker.com

PT – Portugal, Leca da Palmeira
Tel: +351 22 999 7360
parker.portugal@parker.com

RO – Romania, Bucharest
Tel: +40 21 252 1382
parker.romania@parker.com

RU – Russia, Moscow
Tel: +7 495 645-2156
parker.russia@parker.com

SE – Sweden, Spånga
Tel: +46 (0)8 59 79 50 00
parker.sweden@parker.com

SK – Slovakia, Banská Bystrica
Tel: +421 484 162 252
parker.slovakia@parker.com

SL – Slovenia, Novo Mesto
Tel: +386 7 337 6650
parker.slovenia@parker.com

TR – Turkey, Istanbul
Tel: +90 216 4997081
parker.turkey@parker.com

UA – Ukraine, Kiev
Tel: +380 44 494 2731
parker.ukraine@parker.com

UK – United Kingdom, Warwick
Tel: +44 (0)1926 317 878
parker.uk@parker.com

ZA – South Africa, Kempton Park
Tel: +27 (0)11 961 0700
parker.southafrica@parker.com

North America

CA – Canada, Milton, Ontario
Tel: +1 905 693 3000

US – USA, Cleveland
Tel: +1 216 896 3000

Asia Pacific

AU – Australia, Castle Hill
Tel: +61 (0)2-9634 7777

CN – China, Shanghai
Tel: +86 21 2899 5000

HK – Hong Kong
Tel: +852 2428 8008

IN – India, Mumbai
Tel: +91 22 6513 7081-85

JP – Japan, Tokyo
Tel: +81 (0)3 6408 3901

KR – South Korea, Seoul
Tel: +82 2 559 0400

MY – Malaysia, Shah Alam
Tel: +60 3 7849 0800

NZ – New Zealand, Mt Wellington
Tel: +64 9 574 1744

SG – Singapore
Tel: +65 6887 6300

TH – Thailand, Bangkok
Tel: +662 186 7000-99

TW – Taiwan, Taipei
Tel: +886 2 2298 8987

South America

AR – Argentina, Buenos Aires
Tel: +54 3327 44 4129

BR – Brazil, Sao Jose dos Campos
Tel: +55 800 727 5374

CL – Chile, Santiago
Tel: +56 2 623 1216

MX – Mexico, Apodaca
Tel: +52 81 8156 6000