

SAFETY RELIEF VALVE

Types H2, H3, H4 & H5

Sizes 13mm - 32 mm (1/2" - 1 1/4")

FOR AMMONIA, R-12, R-22, R-502 AND OTHER COMMON REFRIGERANTS

FEATURES

- High Capacity
- Excellent Repeatability
- All Stainless Steel Internal Parts
- Maximum Temperature 300°F
- Unaffected By Vibration
- Drain Plug Standard
- PTFE Seat

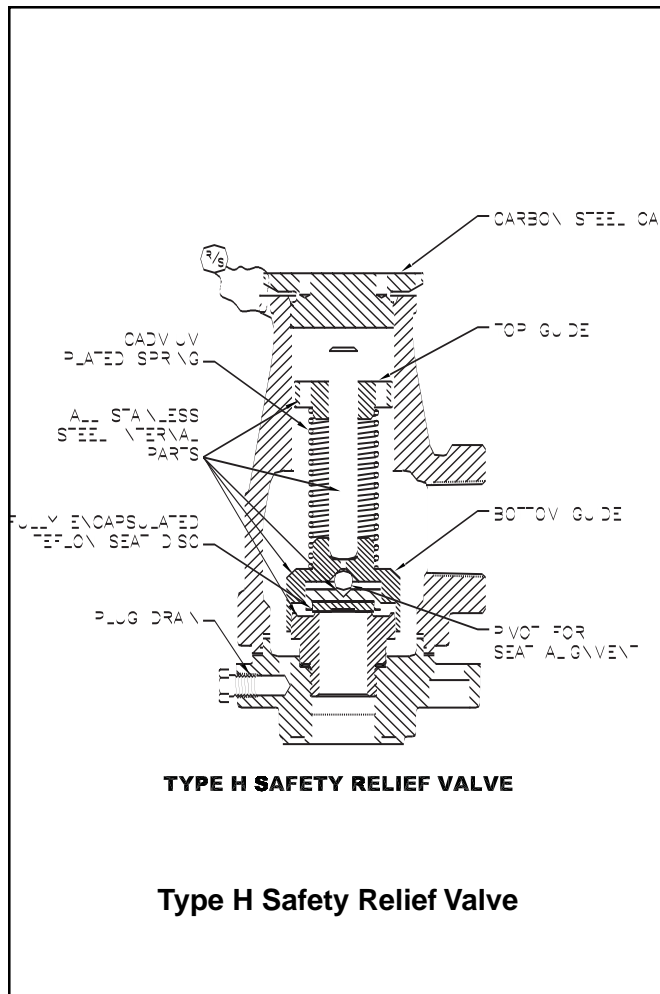

BULLETIN 70-01A TYPE H



Dual Valve
with Manifold



Single Valve

March 2002

Installation, Service and Parts Information

Description

The Type H High Capacity Safety Relief Valves are designed and constructed to meet the requirements of ASME Boiler and Pressure Vessel Code and ANSI/ASHRAE 15-78 Code requirements and bear the ASME Code Symbol (UV) indicating compliance with these codes. Employing proven principles of design, these Safety Relief Valves are highly reliable and dependable. Precision machined moving parts of stainless steel, a PTFE disc and a cadmium plated spring prevent sticking due to corrosion or cold welding, to assure valve opening at the set pressure long after installation. They are not suitable for corrosive ambient atmospheres such as chlorine, etc. The two-bolt flanged bottom inlet affords simple removal and replacement.

Purpose

Safety Relief Valves should be used to protect each refrigeration system pressure vessel that can be isolated by valves. In many localities state or municipal codes govern selection and installation of Relief Valves. Many are patterned after the ASME Boiler and Pressure Vessel Code and the ANSI/ASHRAE 15-78 Safety Code for Mechanical Refrigeration. Where no compulsory code exists, installation of Relief Valves according to this ANSI/ASHRAE Code is highly recommended.

Application

The Type H2 thru H5 valves are for use with Ammonia and Halocarbon refrigerants in non-corrosive environments. Pressure settings and capacities apply only when the valve is discharging to atmospheric pressure.

Pressure Settings

Codes require valve settings equal to or less than design working pressure of the vessel protected. The Type H Safety Relief Valves are available in six standard settings, from 50 psig to 300 psig in 50 lb. increments. Special settings between 50 psig to 300 psig in 25 lb. increments are also available. To retain the validity of the code symbols, pressure settings and capacity, these valves must be set and sealed at the factory. When required, valves can be returned to the factory for verification of setting, or readjustment to the original setting. No major repairs or reconditioning will be done. Contact factory for details.

Dual Relief Valves

The Dual Relief Valve Assembly includes two relief valves and a Dual Stop Valve. This arrangement permits either valve to be shut off individually and removed for repairs or inspection. Thus one valve is always in service as required by most codes. **When the stem is in, the right valve is closed, and when the stem is out, the left valve is closed.**

SINGLE VALVE ONLY						DUAL VALVES WITH MANIFOLDS	
Valve Type	Connections		Capacity			Connections	
	Companion Mounting Flange (Inlet)	Relief Valve Outlet FPT	Pressure Setting psig	Lbs. Per. Min Air	SCFM Air	Manifold Inlet Bottom	Relief Valve Outlet
H2	Provides 3/4" FPT	1"	50	23	302	Type M2 Manifold Provides 3/4" FPT	1" FPT
			100	41	541		
			150	60	780		
			175	69	899		
			200	78	1019		
			225	87	1138		
250	96	1257					
300	114	1496					
H3	Provides 1" FPT	1-1/4"	50	38	498	Type M3 Manifold Provides 1" FPT	1-1/4" FPT
			100	68	890		
			150	98	1283		
			200	128	1676		
			225	143	1872		
			250	158	2068		
300	188	2461					
H4	Provides 1-1/4" FPT	1-1/2"	50	57	744	Type M4 Manifold Provides 1-1/2" FPT	1-1/2" FPT
			100	101	1330		
			150	146	1917		
			200	191	2504		
			250	236	3091		
			300	281	3678		
H5	Provides 1-1/4" FPT	2"	50	95	1242	Type M4 Manifold Provides 1-1/2" FPT	2" FPT
			100	170	2222		
			150	244	3202		
			200	319	4182		
			225	357	4672		
			250	394	5162		
300	469	6143					

Selection Data

The Type H Safety Relief Valve is intended to prevent the pressure of the vessel from rising more than 10% above the Design Working Pressure (DWP) of the vessel or the pressure setting of the relief device, whichever is the lower pressure.

Whenever conditions permit, it is advisable to have the relief valve pressure setting (which must not exceed the design working pressure of the vessel) at least 25% higher than the normal operating pressure for the refrigerant used.

Pressure limiting devices, such as high pressure cutouts on positive displacement compressor systems, must stop the action of the pressure imposing element at no higher than 90% of the pressure setting for the pressure relief device.

For non-positive displacement compressors, the pressure limiting device, such as a high pressure cut-out, may be set at the DWP of the high side; providing, the low side is protected by a properly sized pressure relief device set to relieve pressure at low side DWP and there are no stop valves in the system that isolate the high side from the low side.

Discharge piping from relief devices must not exceed specified lengths indicated in ANSI/ASHRAE 15-78 with discharge to atmosphere.

Per ANSI/ASHRAE 15-78 the minimum required discharge capacity of a relief device for each pressure vessel where vessel is valved off from refrigerating systems is determined as follows: $C = FDL$. Where D = outside diameter of vessel, ft.; L = Length of vessel, ft.; C = Capacity, lb/min air and F = Factor determined as follows:

Refrigerant	F
R-717	0.5
R-12, -22, -500	1.6
R-13, -13B1, -14, -502	2.5
All others	1.0

Space Saving

The high capacity of the Type H valve permits the use of a small size valve which results in space saving. The valves are very compact and sturdy requiring small headroom. The dual valve assembly is especially compact, sturdy and easily assembled.

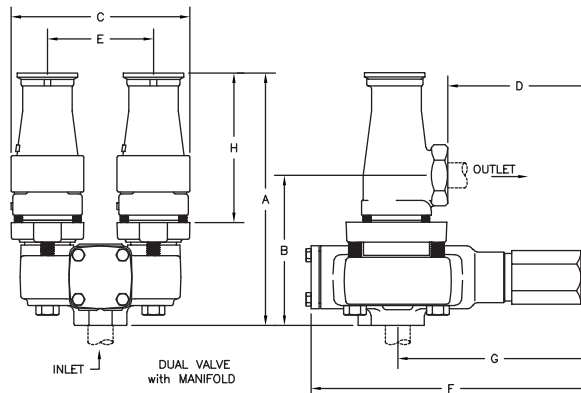
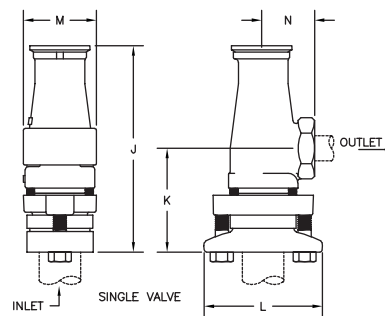

TABLE OF DIMENSIONS								
	H2		H3		H4		H5	
	mm	inch	mm	inch	mm	inch	mm	inch
A	251	9.87	295	11.62	340	13.37	371	14.62
B	152	6.00	187	7.37	211	8.31	224	8.81
C	171	6.75	219	8.62	273	10.75	318	12.50
D	137	5.37	127	5.00	117	4.62	111	4.37
E	102	4.00	127	5.00	165	6.50	165	6.50
F	273	10.75	283	11.12	298	11.75	298	11.75
G	187	7.37	188	7.41	192	7.56	192	7.56
H	166	6.53	202	7.97	237	9.34	266	10.46
I	193	7.59	229	9.03	267	10.53	296	11.65
K	96	3.77	120	4.72	137	5.40	151	5.93
L	102	4.00	102	4.00	122	4.81	122	4.81
M	70	2.75	92	3.62	108	4.25	152	6.00
N	49	1.94	62	2.43	75	2.94	81	3.19
Inlet	20	3/4	25	1	32	1-1/4	32	1-1/4
Outlet	25	1	32	1-1/4	40	1-1/2	50	2

Warranty

All Refrigerating Specialties Products are warranted against defect in workmanship and materials for a period of one year from date of shipment from the factory. This warranty is in force only when products are properly installed, maintained and operated in use and service as specifically stated in Refrigerating Specialties Catalogs or Bulletins for normal refrigeration applications, unless otherwise approved in writing by Refrigerating Specialties Division. Defective products, or parts thereof returned to the factory with transportation charges prepaid and found to be defective by factory inspection will be replaced or repaired at Refrigerating Specialties' option, free of charge, F.O.B. factory. Warranty does not cover products which have been altered or repaired in the field; damaged in transit, or have suffered accidents, misuse, or abuse. Products disabled by dirt, or other foreign substances will not be considered defective.

THE EXPRESS WARRANTY SET FORTH ABOVE CONSTITUTES THE ONLY WARRANTY APPLICABLE TO REFRIGERATING SPECIALTIES PRODUCTS, AND IS IN LIEU OF ALL OTHER WARRANTIES, EXPRESS OR IMPLIED, WRITTEN OR ORAL, INCLUDING ANY WARRANTY OF MERCHANTABILITY, OR FITNESS FOR A PARTICULAR PURPOSE. No employee, agent, dealer or other person is authorized to give any warranties on behalf of Refrigerating Specialties, nor to assume, for Refrigerating Specialties, any other liability in connection with any of its products.