



Single Acting Hydraulic Telescopic Cylinder

SAT Series Service Manual



ENGINEERING YOUR SUCCESS.

In line with our policy of continuing product improvement, specifications and information contained in this catalog are subject to change.

Copyright ©2022 by Parker Hannifin Corporation.
All rights reserved.

PRINTED IN THE U.S.A.

ASSEMBLED IN U.S.A.

⚠ WARNING

FAILURE OR IMPROPER SELECTION OR IMPROPER USE OF THE PRODUCTS AND/OR SYSTEMS DESCRIBED HEREIN OR RELATED ITEMS CAN CAUSE DEATH, PERSONAL INJURY AND PROPERTY DAMAGE.

This document and other information from the Parker Hannifin Corporation, its subsidiaries and authorized distributors provide product and/or system options for further investigation by users having expertise. It is important that you analyze all aspects of your application, including consequences of any failure and review the information concerning the product or system in the current product catalog. Due to the variety of operating conditions and applications for these products or systems, the user, through its own analysis and testing, is solely responsible for making the final selection of the products and systems and assuring that all performance, safety and warning requirements of the application are met.

The products described herein, including without limitation, product features, specifications, designs, availability and pricing, are subject to change by Parker Hannifin Corporation and its subsidiaries at any time without notice.

WARNING!!

Before working on a telescopic cylinder mounted on a truck or trailer unit, use supports or holding devices that will absolutely prevent the body from accidentally lowering. Place control valve in the “Lower” position to assure that all pressure has been relieved from the cylinder.

Offer of Sale

The items described in this document are hereby offered for sale by Parker Hannifin Corporation, its subsidiaries or its authorized distributors. This offer and its acceptance are governed by provisions stated on a separate page of the document entitled 'Offer of Sale'.

⚠ PROP 65 WARNING

Warning: This product can expose you to chemicals including **Lead and Lead Compounds** which are known to the State of California to cause cancer and birth defects or other reproductive harm. For more information go to www.P65Warnings.ca.gov



Table of Contents

Genuine Replacement Service Rebuild and Ring Kits	4-5
Servicing	6-11
Installing New Rebuild Kit	12-15
Hydraulic Oil Recommendations	16
Safety Precautions for SAT Cylinders	17-18
Storage and Installation	19
Cylinder Safety Guide	20-21
Offer of Sale	22

 **PROP 65 WARNING** **WARNING:** This product can expose you to chemicals including **Lead and Lead Compounds** which are known to the State of California to cause cancer and birth defects or other reproductive harm. For more information go to www.P65Warnings.ca.gov

WARNING!!

Before working on a telescopic cylinder mounted on a truck or trailer unit, use supports or holding devices that will absolutely prevent the body from accidentally lowering. Place control valve in the "Lower" position to assure that all pressure has been relieved from the cylinder.

Repair Kits
For Standard Parker Single-acting, Dump Body Cylinders.

SAT Rebuild Kits	
Contains Symbol 1, 2, 3, 5, 6 & 8	
Part Number	Cylinder Series
3751807001	SAT53
3751807002	SAT63
3751807003	SAT64
3751807004	SAT73
3751807005	SAT74
3751807006	SAT84
3751807007	SAT85
3751807008	SAT52
3751807009	SAT72
3751807010	SAT75
3751807011	SAT82
3751807012	SAT83
3751807013	SAT62

Parker's genuine replacement parts are available in rebuild kits and ring kits. These parts are the same as originally installed.

As with all hydraulic repairs, be sure your shop is properly equipped and that the work area is clean.

Rebuild kit includes: wiper, rod seal, rod bearing, piston bearing and static seal for end cap.

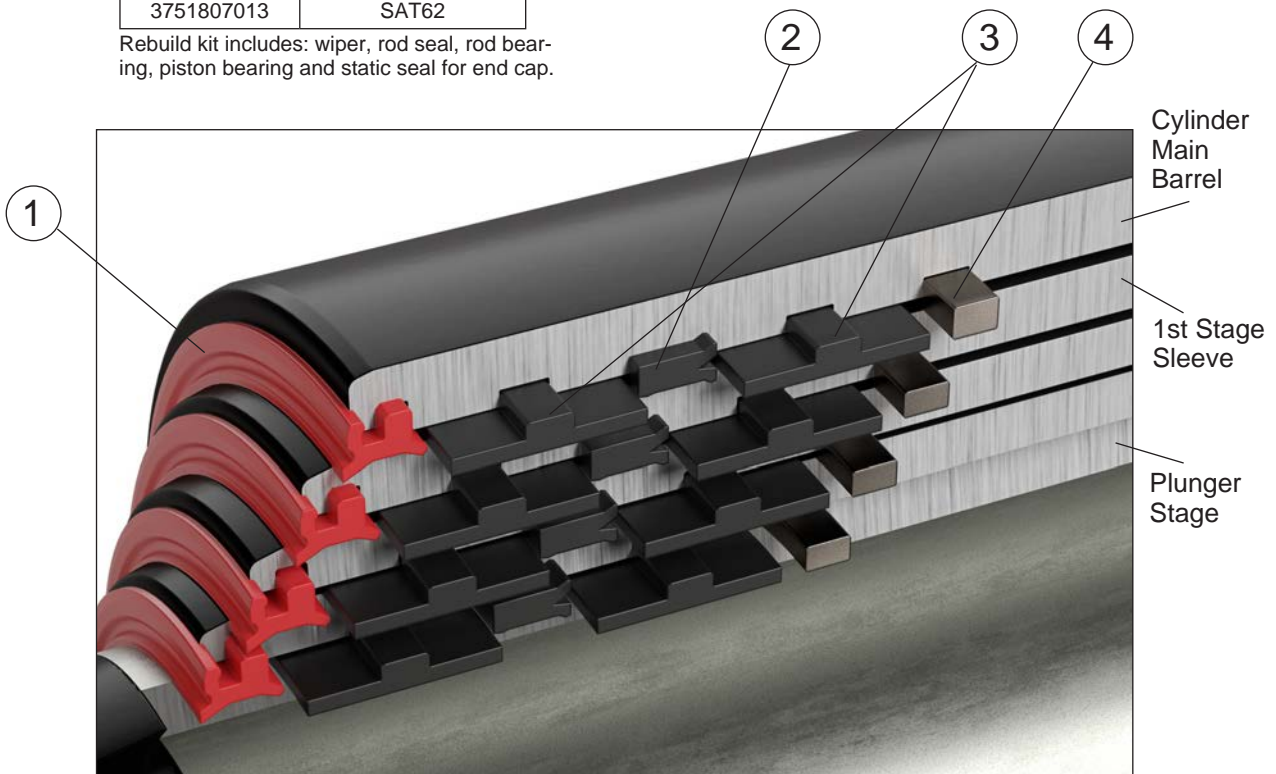

PROP 65 WARNING WARNING: This product can expose you to chemicals including **Lead and Lead Compounds** which are known to the State of California to cause cancer and birth defects or other reproductive harm. For more information go to www.P65Warnings.ca.gov

WARNING!!

Before working on a telescopic cylinder mounted on a truck or trailer unit, use supports or holding devices that will absolutely prevent the body from accidentally lowering. Place control valve in the "Lower" position to assure that all pressure has been relieved from the cylinder.

Ring Kits
For Standard Parker Single-acting, Dump Body Cylinders.

SAT Ring Kits	
Contains Symbol 4, 7, 9 & 10	
Ring Kit Number	Cylinder Series
3751807014	SAT53
3751807015	SAT63
3751807016	SAT64
3751807017	SAT73
3751807018	SAT74
3751807019	SAT84
3751807020	SAT85
3751807021	SAT52
3751807022	SAT62
3751807023	SAT72
3751807024	SAT75
3751807025	SAT82
3751807026	SAT83

Kit includes Sleeve OD and ID Stop Rings, and Roll Pins

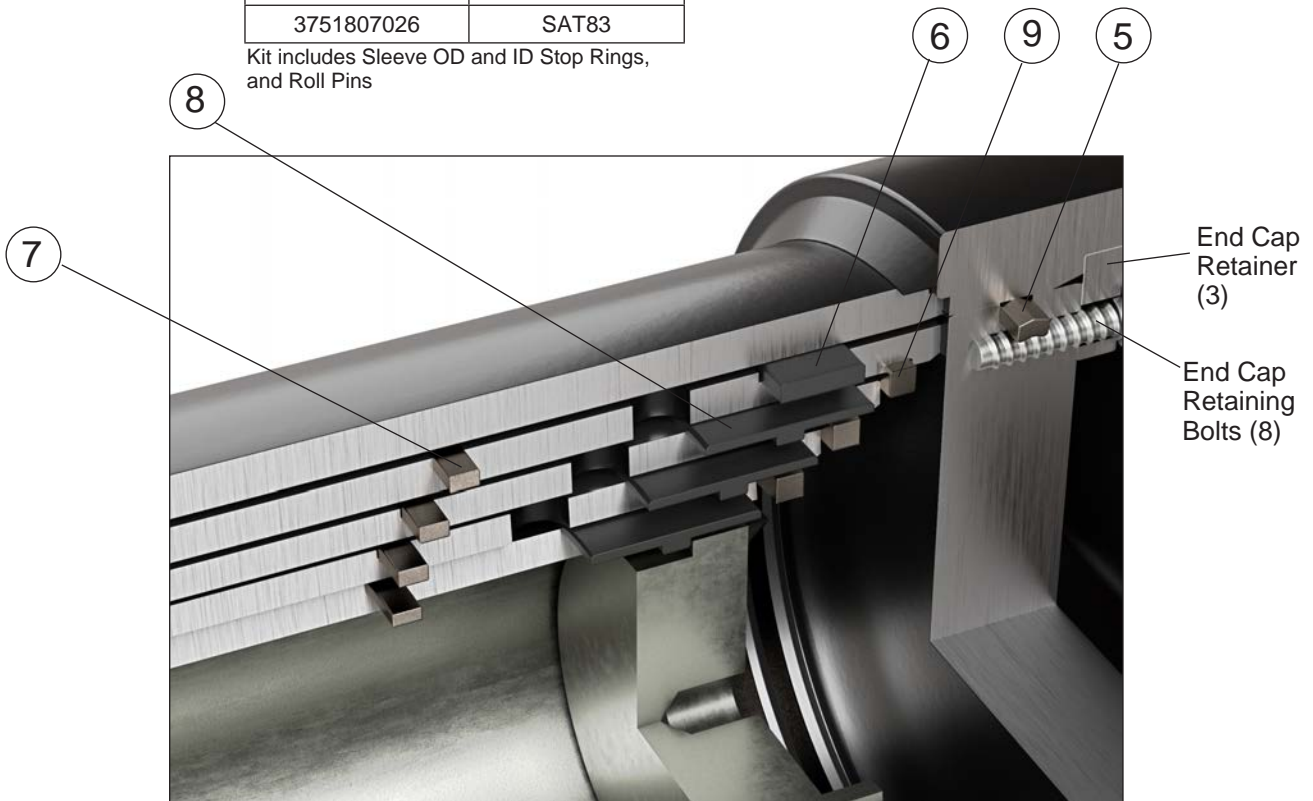
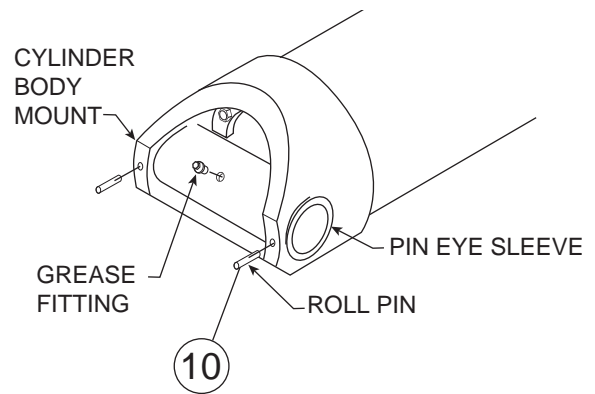

PROP 65 WARNING WARNING: This product can expose you to chemicals including **Lead and Lead Compounds** which are known to the State of California to cause cancer and birth defects or other reproductive harm. For more information go to www.P65Warnings.ca.gov

WARNING!!

Before working on a telescopic cylinder mounted on a truck or trailer unit, use supports or holding devices that will absolutely prevent the body from accidentally lowering. Place control valve in the "Lower" position to assure that all pressure has been relieved from the cylinder.

When a SAT cylinder is overhauled all wiper seals, rod seals, ID wear rings, metallic wear bands, OD wear bands, and end cap static seals should be replaced. All of these items are included in the SAT Rebuild kits. It is also recommended to replace the OD and ID extend stop rings, sleeve end stop rings, and the cross tube retaining roll pins. The stop rings and roll pins are included in the SAT Ring Kits. (See pages 4 and 5 for kits and diagrams).

Recommended Tools

The following tools are recommended for servicing the SAT series cylinders to make servicing easier, safer, and minimize the chances of damaging any of the cylinder components.



Two flat head screwdrivers
(long shank preferred)



Dead blow hammer,
preferably 48 oz.



3/16" pin punch



9/16" Socket and
socket wrench



Vise grip 10"



Ball-peen hammer,
12-16 oz.



5/8"-11, Lifting eye



Lock ring washer pliers



7/16" Wrench



Removable anaerobic
adhesive threadlocker

PROP 65 WARNING WARNING: This product can expose you to chemicals including **Lead and Lead Compounds** which are known to the State of California to cause cancer and birth defects or other reproductive harm. For more information go to www.P65Warnings.ca.gov

Disassembling the Cylinder

Before disassembling the cylinder, inspect each cylinder sleeve for any sign of gouges, scratches, dents, bulges, or corrosion. If any of these conditions exist, contact the factory for additional repair parts or repair instructions.

Note: Make sure to drain cylinder of hydraulic fluid before disassembly.

Caution: Make sure there is no trapped pressure in cylinder before removing the plug from port.

Remove the pin eye sleeve by removing the grease fitting and the 2 roll pins as shown in figure 1 below.

- 1) Remove the grease fitting (7/16" wrench)
- 2) Remove the roll pins by using the 3/16" pin punch and ball peen hammer to drive the roll pins through to the inside of the pin eye sleeve. Reach into the ID of Sleeve to remove roll pins.
- 3) Use dead blow hammer to knock the pin eye sleeve through the cylinder body end mount.

Note: cleaning dirt and paint from outside of the pin eye sleeve can help in removal of the sleeve.

Figure 1

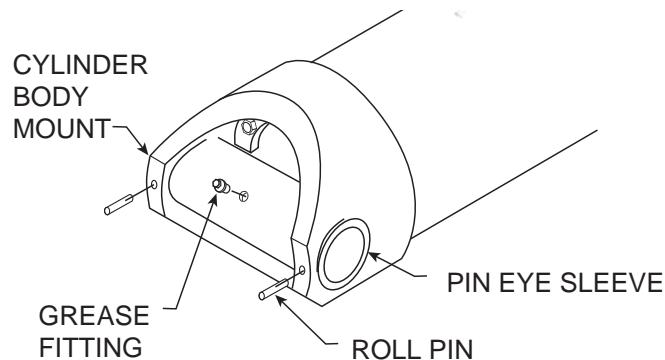
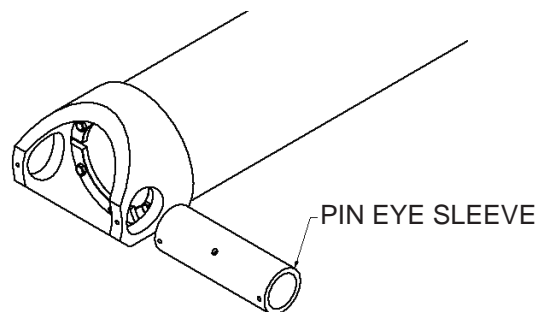

Figure 2



PROP 65 WARNING WARNING: This product can expose you to chemicals including **Lead and Lead Compounds** which are known to the State of California to cause cancer and birth defects or other reproductive harm. For more information go to www.P65Warnings.ca.gov

Remove the End Cap. See Fig 3 & Fig 4

- 1) Use 9/16" socket and wrench to remove (6) 3/8" bolts from end cap.
- 2) Slide the end cap retainer plates toward center of cylinder and pull out.

Note: It might be necessary to tap on back of end cap with the dead blow hammer provide more clearance between end cap and end cap retainers before you can slide them out.

Figure 3

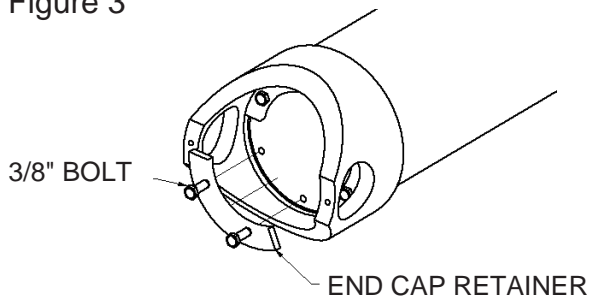

Figure 4

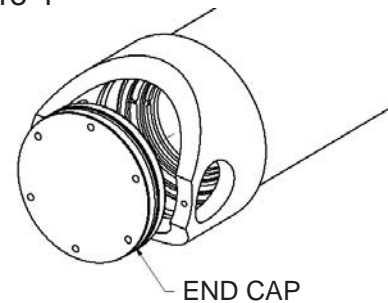
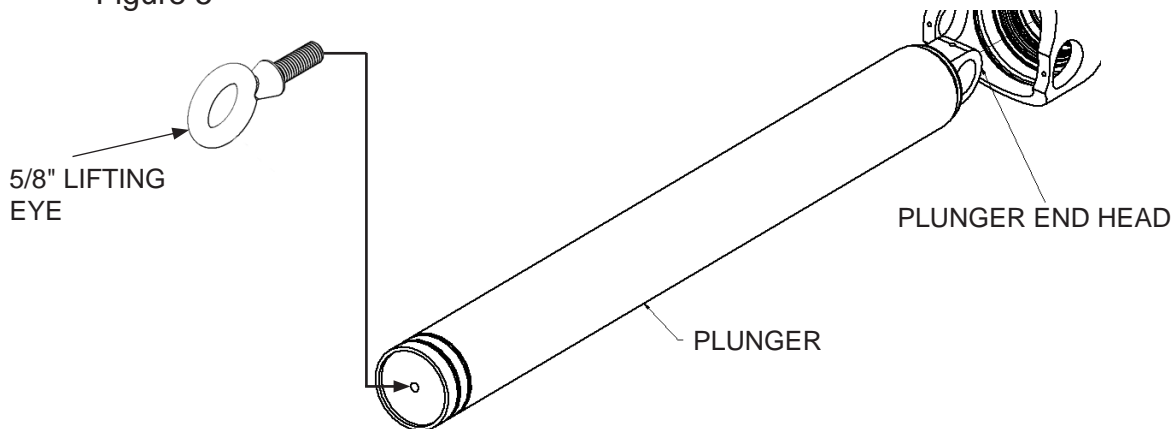

Figure 5



- 3) Tap on plunger end head (Fig. 5) with a dead blow hammer to knock end cap out or use (2) 3/8"-16 x 3" long bolts threaded into 2 of the cap retainer bolt holes to pull out end cap.

Caution: End Cap has a tight seal and may break free without warning. Take care to support the end cap so that if it does break free it is not damaged or fall on anyone's hands or feet.

PROP 65 WARNING WARNING: This product can expose you to chemicals including **Lead and Lead Compounds** which are known to the State of California to cause cancer and birth defects or other reproductive harm. For more information go to www.P65Warnings.ca.gov

Remove all nested stages from the main cylinder barrel

Remove the Plunger assembly and all other moving stages from the main barrel by threading the 5/8-11 lifting eye into the bottom of the plunger and pulling all the nested stages out of the main barrel. See Fig. 5.

Remove all remaining cylinder stages

- 1) Using a 7/16 inch wrench, remove the grease fitting from the plunger end head. See Fig. 5
- 2) Thread the 5/8- 11 lifting eye into the back of the plunger assembly. See Fig. 5
- 3) Remove the sleeve end stop ring from the cylinder stage that is holding in the plunger.
 - a. You may need to tap the bottom of the plunger with the dead blow hammer to move it forward enough to have room to remove the stop ring.



Figure 6

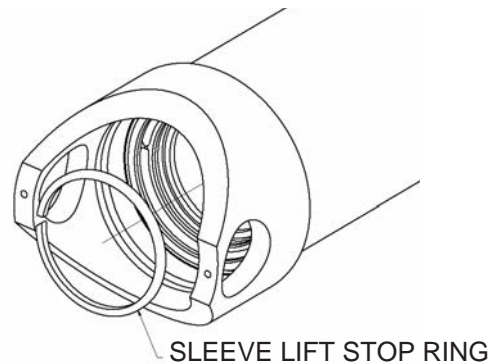

Figure 7

- b. Use vise grips and a long shank screw driver to pry ring from groove. Pry up on the vise grips after prying ring from groove. See Fig. 6 and 7.
- 4) Pull the plunger assembly out from the nested cylinder stages using the lifting eye.

Note: Use care not to damage plunger OD or the ID of the sleeve as you remove the plunger.

Caution: Rings are under tension and can spring out and cause injury, it is recommended to wear a face shield.

- 5) Remove the next sleeve by repeating step 3 above and slide each stage out as the sleeve end stop rings are removed. Continue repeating until all stages have been removed.

Remove OD Wear Rings and Sleeve Stop Rings, ID wear rings, ID stop rings, wipers, and rod seals.

- 1) Remove Sleeve Stop Rings from all sleeves and plunger using the lock ring washer pliers. See Fig. 8.

Figure 8

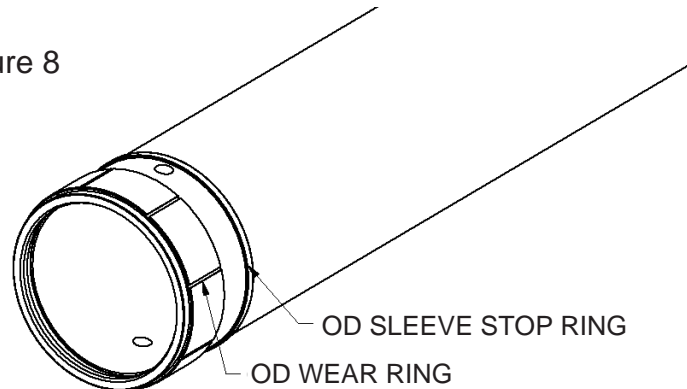

- 2) Remove the Metallic OD wear ring on the 1st moving stage using the lock ring washer pliers. See Fig. 9.

Figure 9

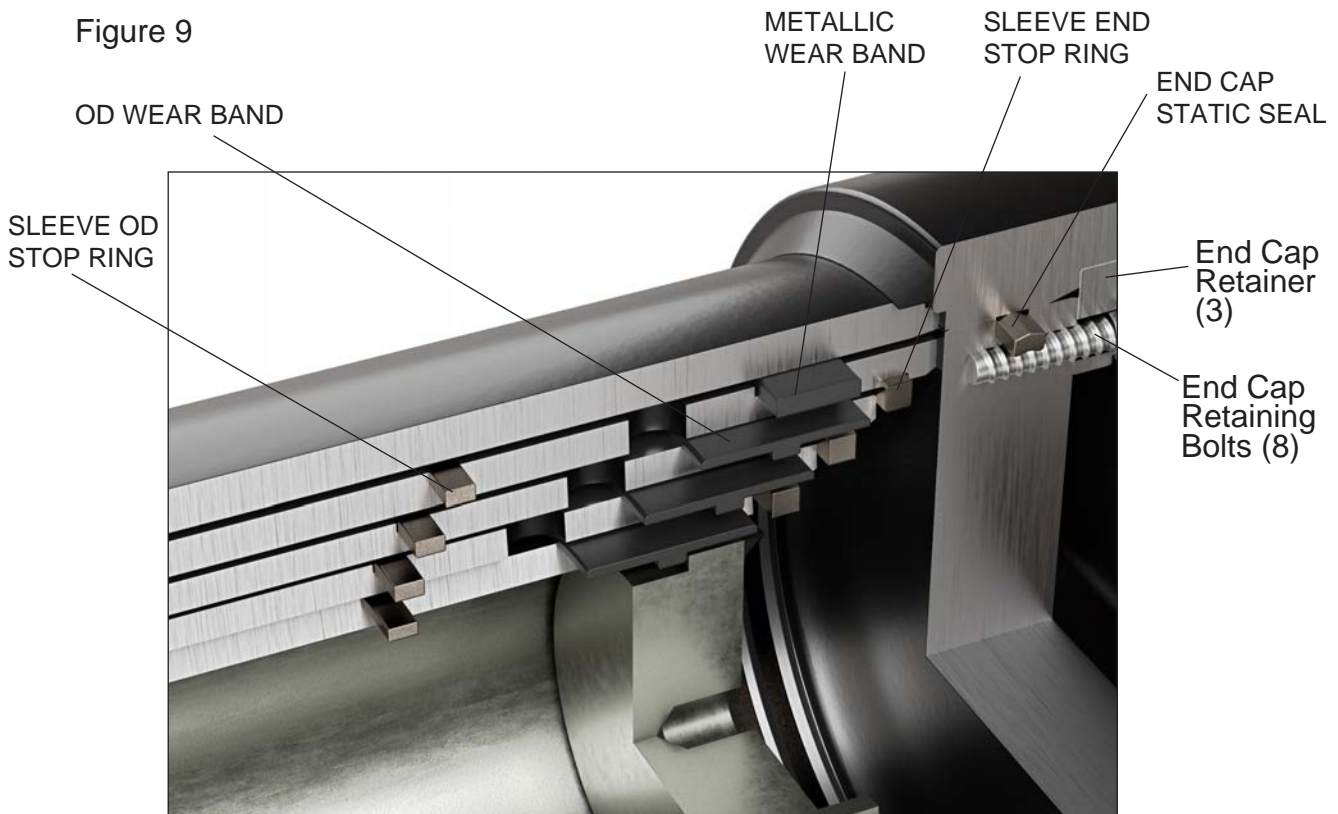

⚠ PROP 65 WARNING WARNING: This product can expose you to chemicals including **Lead and Lead Compounds** which are known to the State of California to cause cancer and birth defects or other reproductive harm. For more information go to www.P65Warnings.ca.gov

- 3) Remove ID Wipers, ID Wear Rings, ID stop rings and Rod Seals. Be careful not to damage grooves when removing components. See Fig. 10.

Figure 10

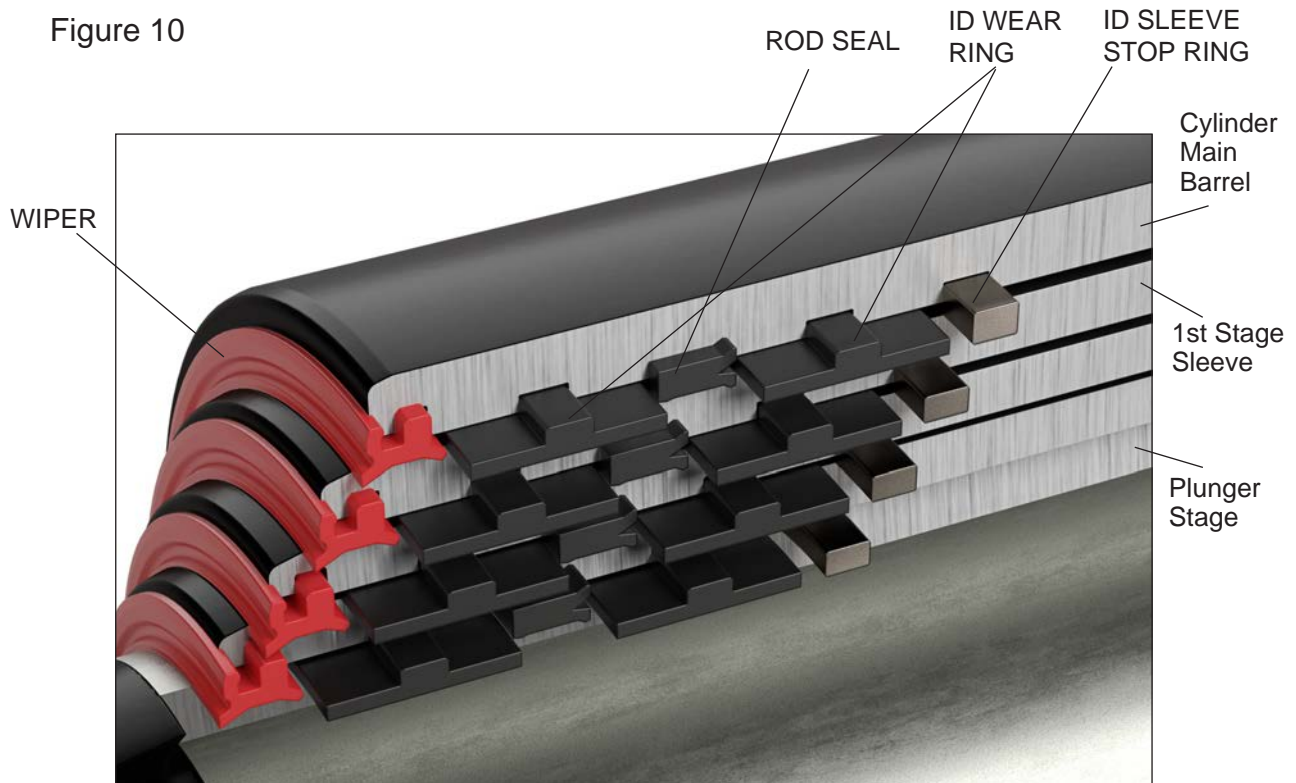

- 4) Be sure to drain and remove all old oil from the sleeves and main barrel. Clean all the cylinder parts: cylinder main barrel, cylinder sleeves, and plunger with an eco-friendly degreaser and be sure all parts are dry before reinstalling the new seals, wear rings, and stop rings.

Inspect Cylinder Parts

- 1) Inspect the main barrel, all the sleeves and the plunger for scratches, dings, dents, or gouges and insure none of them are bent. Small scratches, no deeper than .003 deep, can be polished out with a fine emery cloth, 600 grit.
- 2) Inspect the ID and OD stop ring grooves for damage. If there is any deformation to the ring grooves then the sleeve, plunger, or main barrel with the damaged groove should be replaced.
- 3) Inspect the OD and ID stop rings for damage. If the rings are bent or deformed in any way they should be replaced.

⚠ PROP 65 WARNING WARNING: This product can expose you to chemicals including **Lead and Lead Compounds** which are known to the State of California to cause cancer and birth defects or other reproductive harm. For more information go to www.P65Warnings.ca.gov

Installing new rebuild kit.

- 1) Apply Parker Lube-A-Cyl grease Part Number 0761630000 or equivalent, to the ID of the rod seal, wiper seal and ID wear ring grooves. Also apply to the OD wear band grooves
- 2) Apply Parker Lube-A-Cyl grease or equivalent to the OD and ID wear bands, Metallic wear band, rods seals, and wiper seals.
- 3) Install the new components in the following order: ID wear rings, ID sleeve stop rings, rod seals, and then wiper seals into the main barrel and sleeves.

Note: Direction of seals, if installed improperly it will cause leakage and/or binding. For the wiper seal note the notch/groove on the front face of the seal is facing the outside of the cylinder sleeve. See Fig. 11.

Figure 11

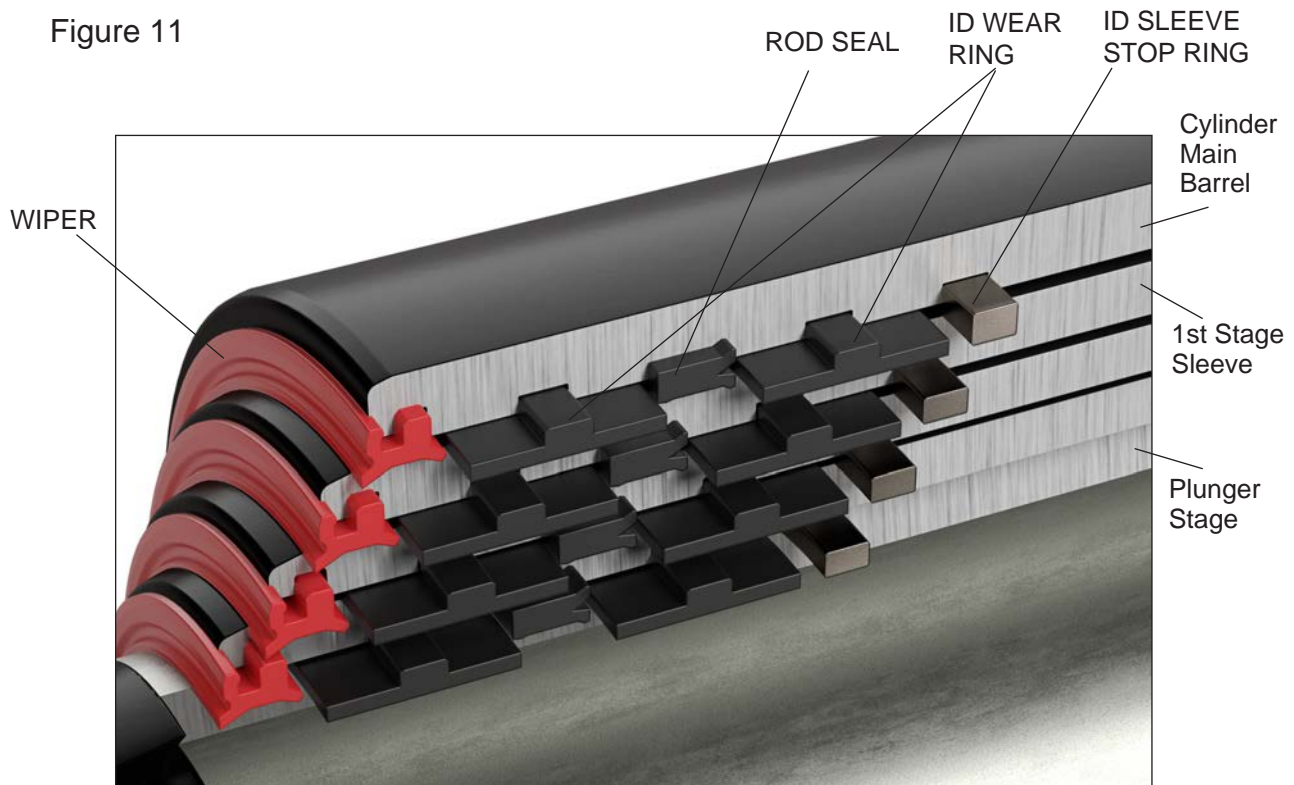

⚠ PROP 65 WARNING WARNING: This product can expose you to chemicals including **Lead and Lead Compounds** which are known to the State of California to cause cancer and birth defects or other reproductive harm. For more information go to www.P65Warnings.ca.gov

- 4) Install Sleeve OD Stop Rings on the sleeves and plunger using the lock ring washer pliers. See Fig. 12.

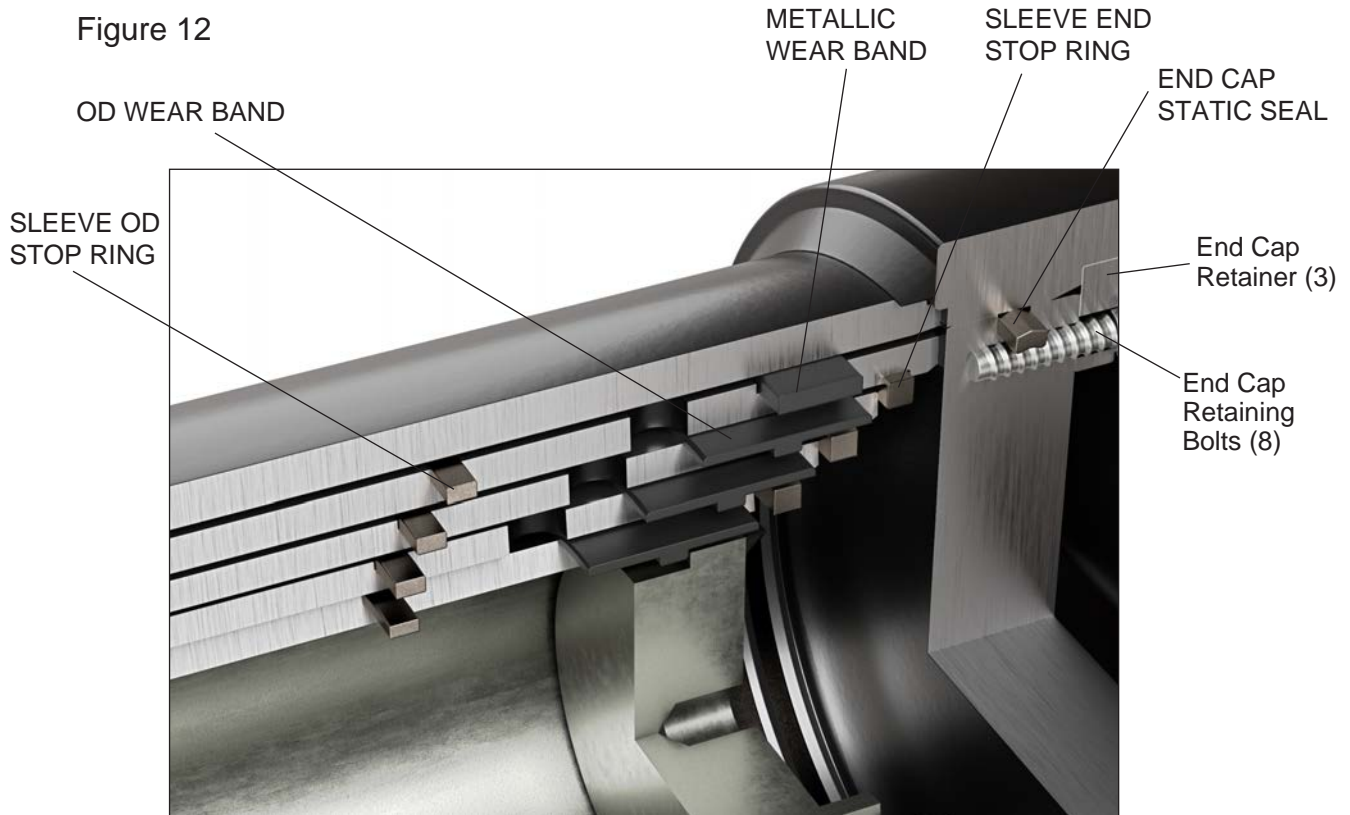

- 5) Install OD wear bearing on the sleeves and plunger. See Fig 12.
- 6) Install the metallic wear bearing on the 1st moving sleeve using the lock ring washer pliers.

⚠ PROP 65 WARNING **WARNING:** This product can expose you to chemicals including **Lead and Lead Compounds** which are known to the State of California to cause cancer and birth defects or other reproductive harm. For more information go to www.P65Warnings.ca.gov

Install sleeves and plunger into cylinder main barrel.

- 1) Lubricate the seals and sleeve/plunger with hydraulic oil before installing into main barrel.
- 2) Install the 1st sleeve (largest moving stage) into the cylinder main barrel. The sleeve will meet resistance when it gets to the seals. It will require some force to push the sleeve through the seals.

Caution: If assembling horizontal; guide the sleeves so it is not rubbing or scratching the ID of the cylinder main barrel and do not let the sleeves rub the ID stop ring as this can cause damage to the OD of the sleeve.

- 3) Install the sleeve end stop ring.
- 4) Install the next moving sleeve (2nd Stage) into the 1st stage The second stage will need to pass the end of the 1st stage approximately 1 to 2 inches to install the sleeve end stop ring.
- 5) Install the sleeve end stop ring.
- 6) Repeat steps 4 and 5 above until all remaining sleeves and plunger have been installed.

Caution: Make sure all sleeve end stop rings are securely installed into the grooves.

Install Cylinder end cap.

- 1) Install end cap static seal on to end cap.
- 2) Lubricate the end cap static seal with Lube-A-Cyl grease or equivalent.
- 3) Place end cap in place in cylinder body mount, push in place. Use the dead blow hammer to tap the end cap into place and be sure the cap is in past the end cap retainer groove.
- 4) Install the three end cap retainer pieces into place. If they are difficult to slide into the grooves, tap the end cap into the cylinder body a little farther.
- 5) Apply Loctite 242 or equivalent to the 3/8 inch bolts.
- 6) Install the 3/8 inch bolts and torque to 34 lbs-ft.
- 7) Install body mount pin eye sleeve into body mount. Be sure the roll pin holes on the sleeve line up with the roll pin holes on the body mount and the threads for the grease fitting are positioned in a location that will allow easy access to lubricate pin eye sleeve.
- 8) Drive in the 2 roll pins using the ball-peen hammer. Make sure the pins are in both the body mount and pin eye sleeve.
- 9) Install grease fitting into the plunger end head and the pin eye sleeve.

 **PROP 65 WARNING** **WARNING:** This product can expose you to chemicals including **Lead and Lead Compounds** which are known to the State of California to cause cancer and birth defects or other reproductive harm. For more information go to www.P65Warnings.ca.gov

Testing Rebuilt Cylinder in truck.

- 1) Install cylinder on truck, making sure to follow all safety requirements specified by truck manufacturer.
- 2) Make sure all pins are fully secured
- 3) Grease the pins.
- 4) Connect hydraulic hose to cylinder
- 5) Check the hydraulic fluid in tank before operating cylinders. Make sure it is at the proper level.
- 6) Make sure all connections are tight. Loose connections may cause high pressure leaks and also allow air to get into the hydraulic system.
- 7) Be sure all personnel is clear before testing cylinder.
- 8) Test dumping cylinder.
- 9) This cylinder is a bleederless design. The cylinder should be fully cycled 5 to 7 times to bleed air from the cylinder.
- 10) Check all fitting connections and hoses for leaks.
- 11) Check each cylinder stage for any sign of leakage.

 **PROP 65 WARNING** **WARNING:** This product can expose you to chemicals including **Lead and Lead Compounds** which are known to the State of California to cause cancer and birth defects or other reproductive harm. For more information go to www.P65Warnings.ca.gov

All cylinder parts, with the exception of a few items, are lubricated by the hydraulic oil in the circuit. Particular attention must be paid to keep the oil in the circuit clean. Whenever there is a hydraulic component failure (cylinder, pump, valve), and there is a reason to feel that metal particles may be in the system, the oil must be drained, the entire system flushed clean, and any filter screens thoroughly cleaned or replaced. New oil should be supplied for the entire system. Oil suitable and recommended for use in circuits involving Commercial cylinders should meet the following specifications:

***These suggestions are intended as a guide only.
Obtain your final oil recommendations from your oil supplier.***

Viscosity Recommendations:

Optimum operating viscosity is considered to be about 100 SSU.

- * 50 SSU minimum @ operating temperature
7500 SSU maximum @ starting temperature
- * 150 to 225 SSU @ 100° F. (37.8° C.) (generally)
44 to 48 SSU @ 210° F. (98.9° C.) (generally)

Other Desirable Properties:

Viscosity Index: 90 minimum
Aniline point: 175 minimum

Additives Usually Recommended:

Rust and Oxidation (R & O) Inhibitors
Foam Depressant

Other Desirable Characteristics:

Stability of physical and chemical characteristics.
High demulsibility (low emulsibility) for separation of water, air and contaminants.
Resistant to the formation of gums, sludges, acids, tars and varnishes.
High lubricity and film strength.

General Recommendations:

A good quality hydraulic oil conforming to the characteristics listed above is essential to the satisfactory performance and long life of any hydraulic system.

Oil should be changed on regular schedules in accordance with the manufactures recommendations and the system periodically flushed.

Oil operating temperature should not exceed 200° F. (93° C.) with a maximum of 180° F. (82° C.) generally recommended. 120° F. to 140° F. (50° C. to 60° C.) is generally considered optimum. High temperatures result in rapid oil deterioration and may point out a need for an oil cooler or a larger reservoir. The nearer to optimum temperature, the longer the service life of the oil and the hydraulic components.

Reservoir size should be large enough to hold and cool all the fluid a system will need, yet it should not be wastefully large. Minimum required capacity can vary anywhere between 1 and 3 times pump output. The reservoir must be able to hold all of the fluid displaced by retracted cylinders when the system is not operating, yet provide space for expansion and foaming.

Oil poured into the reservoir should pass through a 100 mesh screen. Pour only clean oil from clean containers into the reservoir.

Never use Crank Case Drainings, Kerosene, Fuel Oil, or any Non-Lubricating Fluid, such as Water.

Approximate SSU at . . .

Oil Grade	100° F. (37.8° C.)	210° F. (98.9° C.)
SAE 10	150	43
SAE 20	330	51

Normal Temperatures:

0° F. (-18° C.) to 100° F. (37.8° C.) ambient
100° F. (37.8° C.) to 180° F. (82.2° C.) system

Be sure the oil you use is recommended for the temperature you expect to encounter.

⚠ PROP 65 WARNING WARNING: This product can expose you to chemicals including **Lead and Lead Compounds** which are known to the State of California to cause cancer and birth defects or other reproductive harm. For more information go to www.P65Warnings.ca.gov



WARNING!

Telescopic cylinders commonly installed on dumping vehicles are devices intended to provide only a lifting force. The cylinder is not a structural member, and is not designed for, nor intended to provide stability to the dumping vehicle. Rollover or lateral tilt can cause the cylinder to bend, buldge or separate causing the dump body to drop suddenly, resulting in severe injury or death and/or damage to the unit and cylinder, if the following warnings are not observed.

Hydraulic cylinders are not to be used as a stabilizer on a dump body or dump trailer. The hydraulic cylinder will not prevent the dump body or trailer from rollover or lateral tilt. The cylinder is strictly a lifting device and is not a structural member of the unit. Cylinders are not to be used as a means of stabilizing the unit.

The hydraulic cylinder mounted in the unit should be free to find its own trajectory line of extension, free of any lateral loading of the plungers. Misalignment of the top or bottom mountings, or mounting pins too tight, may cause scoring of the plungers, leaking, or improper sequencing which could cause the unit to upset.

The hydraulic cylinder will not withstand lateral or side pressure when the unit is leaning. Only activate the cylinder when the tractor and trailer are in a straight line (not jack-knifed). A jackknife position of the tractor with the trailer is not recommended when dumping. In a jackknifed position, the upper coupler pivots on bearings, contributing nothing to dump stability. When the tractor and trailer are straight, the coupler bearings are normally 34 inches apart, assisting in stabilizing the dump.

Do not activate the cylinder while on unlevel or soft ground, or during heavy crosswinds. Doing so may cause the unit to upset. Uneven terrain, causing the trailer wheels to be 3 1/2 inches to 4 inches higher than the other side, puts the top of the body 12 inches to 14 inches off center when the cylinder is fully extended. On fresh fill, loaded trailer wheels may sink on one side, again setting up potential tip over. On road construction, the crown is also critical on spread application, as in dumping on a slope. A 4 inch plus, height differential of wheels on an axle 8 feet wide, is another rollover potential. Do not attempt dumping operations in high gusty wind conditions. If possible, raise the dump body directly into the wind.

A blown tire or a severely under inflated tire can cause dump instability, when dumping. Always check tires visually for cuts or punctures by nails and metal. Make sure all tires are inflated properly. Proper tire inflation also improves wear and fuel economy.

Do not activate the cylinder while personnel or equipment are alongside or behind the dump body or trailer.

A hung load is material that does not discharge when a dump body is raised to an elevated position. This condition exists due to surface adhesion between the material and the interior of the dump body. To avoid a tip over due to a hung load, the driver should be warned by an observer or be aware of the material's moisture content, if this condition exists, immediately lower the dump body.

The operator should stay at the controls during the entire dumping operation. An operator who fails to stay at the controls will never control the body when it starts to lean over for a tip over. If a problem exists, and the body starts to lean, the operator should immediately lower the dump body or trailer and check and remedy any potential problems, then resume dumping the load. It is important to slowly position the cylinder control valve into the hold position to avoid subjecting the cylinder to a high pressure.

Do not overload the unit. The load must be distributed evenly during loading or unloading to avoid rollover and lateral tilt. Loads stuck while the cylinder is partially or completely extended increases the hazard of rollover and lateral tilt. Lower the dump body or trailer entirely with the cylinder control valve partially open (avoid lowering the dump body or trailer with the cylinder control valve completely open). Then unload the dump body or trailer manually or with an alternative mechanical aid.

Overloading is a very common occurrence that aggravates all the above conditions that cause a tip over.

⚠ PROP 65 WARNING **WARNING:** This product can expose you to chemicals including **Lead and Lead Compounds** which are known to the State of California to cause cancer and birth defects or other reproductive harm. For more information go to www.P65Warnings.ca.gov



WARNING!

Shock pressure can cause severe injury or death and/or damage to the unit and cylinder.

Do not use the cylinder to loosen loads stuck in the dump body or trailer. Lower the dump body or trailer entirely with the cylinder control valve partially open (avoid lowering the dump body or trailer with the cylinder control valve completely open). Then unload the dump body or trailer manually or with an alternative mechanical aid.

Humping is a rapid acceleration / deceleration method used to loosen a hung load from a trailer. If the load is off center and the trailer is moved, a tip over may occur. Also, serious damage to the hoist may occur if an extreme humping motion is used to get a sticky load out of the body.

Do not move the truck and jam the brakes while the cylinder is partially or fully extended to loosen loads stuck in the dump body or trailer. Pulling forward (or backing up) and hitting the brakes, or lowering the body part way and then quickly engaging the valve in the "HOLD" or "RAISE" position will cause a tremendous pressure spike. This pressure spike may bulge or split one of the larger stages of the cylinder. Lower the dump body or trailer entirely with the cylinder control valve partially open (avoid lowering the dump body or trailer with the cylinder control valve completely open). Then unload the dump body or trailer manually or with an alternative mechanical aid.

Do not move the truck until the dump body or trailer is lowered completely.

WARNING!

Over pressurizing the cylinder can cause severe injury or death and/or damage to the unit and cylinder.

(Normally 2,500 P.S.I. unless otherwise approved).

Do not operate a cylinder at pressures above factory recommended operating pressures

WARNING!

Worn or damaged hydraulic hoses can cause severe injury or death and/or damage to the unit and cylinder.

Hydraulic hoses should be checked regularly and replaced if worn out or damaged.

NOTICE!

Do not drive the unit while the P.T.O. or hydraulic pump is engaged.

The hydraulic oil should be checked and changed regularly to avoid contamination leading to internal cylinder damage.

A damp to light film of oil on each plunger indicates a good cylinder operation. A small accumulation of oil may be noticed on the plunger at the head nuts after many cycles. This should not be mistaken for leakage.

Cylinder should be free of entrapped air. It is advisable to bleed air from the cylinder weekly to free entrapped air. This will result in a smoother operation.

The cylinder should float in the pin mountings. The cylinder should be installed with 1/8" to 3/16" of clearance between the pin and the pin hole if the mounting eye is wider than 5", or with 1/16" to 1/8" clearance if the mounting eye is less than 5" wide. There should be a clearance of 1/8" to 1/4" per side on eyes less than 5" wide and 1/4" to 1/2" clearance per side on eyes in excess of 5" wide. This is to allow the body to sway slightly while dumping, without putting a side load on the cylinder. The cylinder plunger or one of the sleeves should be extended a minimum of 1/4" when the dump body is in the down position.

⚠ PROP 65 WARNING **WARNING:** This product can expose you to chemicals including **Lead and Lead Compounds** which are known to the State of California to cause cancer and birth defects or other reproductive harm. For more information go to www.P65Warnings.ca.gov



STORAGE

It pays to keep spare hydraulic cylinders on hand for use when you need them. But, you must know and follow these recommended storage practices or the cylinders can be ruined. Hydraulic cylinders, though often large and unwieldy, are precision machines with finely finished parts and close tolerances. And they're expensive. So handle them with care.

For optimum storage life, hydraulic cylinders should be kept in an environment that is protected from excessive moisture and temperature extremes. A hot, dry desert climate with cold nights, for example, must be accommodated when choosing the storage area. Daytime heat quickly bakes oil out of sealing materials, which causes leaks and rapid wear when the cylinder is placed in service. Cooling at night causes water condensation and corrosion damage to wear surfaces. Storage areas that allow exposure to rain, snow and extreme cold must like wise be avoided.

It's best to store cylinders indoors if possible. But indoors or out, be sure that plugs or closures are properly installed in all ports to keep out moisture and dirt. However, overtightening of port plugs should be avoided. Widely varying temperatures and tightly closed ports may cause pressure inside the cylinder to build up to the point where the piston moves far enough to expose the rod to corrosion or contamination. Try to choose a storage location where the cylinders are protected from physical damage. Even a little ding from a falling bar or forklift tine can cause trouble later.

Cylinders, Particularly large ones, should be stored closed in a vertical position with the rod end down. Be sure they're blocked securely to keep them from toppling. Storing with the rod ends down keeps oil on the seals, which protects them from drying out. This is more critical with fabric and butyl seals than with urethane sealing materials. Storing single-acting cylinders with the rod end up can cause port closures to pop open and leak, exposing the sleeves to corrosion damage and contamination. Storing with the rod end down also discourages the temptation to lift a cylinder by the rod eye – a dangerous practice. If horizontal storage cannot be avoided, the rod or cylinder should be rolled into a new position every two months or so to prevent drying, distortion and deterioration of the seals. Don't forget that a cylinder can be a major source of contamination. A small scratch or nick on the sleeve will quickly shred packing and contaminate the system. Store cylinders carefully and keep them clean.

The following procedures should be followed in order to prevent oxidation and maintain the surfaces of a mounted hydraulic cylinder during idle periods. These idle periods may include; inventory units, demo units, out of service units, etc.

- All machined surfaces left expose should be coated with a light film of grease, if not oxidation will occur.
- If oxidation is present, apply a light coat of oil to the surfaces.
- Buff surfaces with 320 or 400 grit sandpaper. Do not buff surfaces up and down the length, buff only around the circumference.
- If after buffing, the surfaces show evidence of oxidation damage i.e., pitting, the cylinder should be inspected by an authorized service center for evaluation.
- Operation of a hydraulic cylinder with surface damage will shorten the longevity and preclude any warranty express or implied.

INSTALLATION

- Cleanliness is an important consideration, and Parker cylinders are shipped with the ports plugged to protect them from contaminants entering the ports. These plugs should not be removed until the piping is to be installed. Before making the connection to the cylinder ports, the piping should be thoroughly cleaned to remove all chips or burrs which might have resulted from threading or flaring operations. One small foreign particle can cause premature failure of the cylinder or other hydraulic system components. If oxidation is present, apply a light coat of oil to the surfaces.
- Proper alignment of the cylinder piston rod and its mating component on the machine should be checked in both the extended and retracted positions. Improper alignment will result in excessive rod gland and/or cylinder bore wear.
- Cylinders operating in an environment where air drying material are present such as fast- drying chemicals, paint, or welding splatter, or other hazardous conditions such as excessive heat, should have shields installed to prevent damage to the piston rod and piston rod seals.

⚠ PROP 65 WARNING **WARNING:** This product can expose you to chemicals including **Lead and Lead Compounds** which are known to the State of California to cause cancer and birth defects or other reproductive harm. For more information go to www.P65Warnings.ca.gov



Safety Guide for Selecting and Using Hydraulic, Pneumatic Cylinders and Their Accessories

WARNING: ⚠ **FAILURE OF THE CYLINDER, ITS PARTS, ITS MOUNTING, ITS CONNECTIONS TO OTHER OBJECTS, OR ITS CONTROLS CAN RESULT IN:**

- Unanticipated or uncontrolled movement of the cylinder or objects connected to it.
- Falling of the cylinder or objects held up by it.
- Fluid escaping from the cylinder, potentially at high velocity.

THESE EVENTS COULD CAUSE DEATH OR PERSONAL INJURY BY, FOR EXAMPLE, PERSONS FALLING FROM HIGH LOCATIONS, BEING CRUSHED OR STRUCK BY HEAVY OR FAST MOVING OBJECTS, BEING PUSHED INTO DANGEROUS EQUIPMENT OR SITUATIONS, OR SLIPPING ON ESCAPED FLUID.

Before selecting or using Parker Hannifin Corporation (the Company) cylinders or related accessories, it is important that you read, understand and follow the following safety information. Training is advised before selecting and using the Company's products.

1.0 General Instructions

1.1 Scope – This safety guide provides instructions for selecting and using (including assembling, installing, and maintaining) cylinder products. This safety guide is a supplement to and is to be used with the specific Company publications for the specific cylinder products that are being considered for use.

1.2 Fail Safe – Cylinder products can and do fail without warning for many reasons. All systems and equipment should be designed in a fail-safe mode so that if the failure of a cylinder product occurs people and property won't be endangered.

1.3 Distribution – Provide a free copy of this safety guide to each person responsible for selecting or using cylinder products. Do not select or use the Company's cylinders without thoroughly reading and understanding this safety guide as well as the specific Company publications for the products considered or selected.

1.4 User Responsibility – Due to very wide variety of cylinder applications and cylinder operating conditions, the Company does not warrant that any particular cylinder is suitable for any specific application. This safety guide does not analyze all technical parameters that must be considered in selecting a product. The hydraulic and pneumatic cylinders outlined in this catalog are designed to the Company's design guidelines and do not necessarily meet the design guideline of other agencies such as American Bureau of Shipping, ASME Pressure Vessel Code etc. The user, through its own analysis and testing, is solely responsible for:

- Making the final selection of the cylinders and related accessories.
- Determining if the cylinders are required to meet specific design requirements as required by the Agency(s) or industry standards covering the design of the user's equipment.
- Assuring that the user's requirements are met, OSHA requirements are met, and safety guidelines from the applicable agencies such as but not limited to ANSI are followed and that the use presents no health or safety hazards.
- Providing all appropriate health and safety warnings on the equipment on which the cylinders are used.

1.5 Additional Questions – Call the appropriate Company technical service department if you have any questions or require any additional information. See the Company publication for the product being considered or used, or call 1-847-298-2400, or go to www.parker.com, for telephone numbers of the appropriate technical service department.

2.0 Cylinder and Accessories Selection

2.1 Seals – Part of the process of selecting a cylinder is the selection of seal compounds. Before making this selection, consult the "seal information page(s)" of the publication for the series of cylinders of interest.

The application of cylinders may allow fluids such as cutting fluids, wash down fluids etc. to come in contact with the external area of the cylinder. These fluids may attack the piston rod wiper and or the primary seal and must be taken into account when selecting and specifying seal compounds.

Dynamic seals will wear. The rate of wear will depend on many operating factors. Wear can be rapid if a cylinder is mis-aligned or if the cylinder has been improperly serviced. The user must take seal wear into consideration in the application of cylinders.

2.2 Piston Rods – Possible consequences of piston rod failure or separation of the piston rod from the piston include, but are not limited to are:

- Piston rod and or attached load thrown off at high speed.
- High velocity fluid discharge.
- Piston rod extending when pressure is applied in the piston retract mode.

Piston rods or machine members attached to the piston rod may move suddenly and without warning as a consequence of other conditions occurring to the machine such as, but not limited to:

- Unexpected detachment of the machine member from the piston rod.
- Failure of the pressurized fluid delivery system (hoses, fittings, valves, pumps, compressors) which maintain cylinder position.
- Catastrophic cylinder seal failure leading to sudden loss of pressurized fluid.
- Failure of the machine control system.

Follow the recommendations of the "Piston Rod Selection Chart and Data" in the publication for the series of cylinders of interest. The suggested piston rod diameter in these charts must be followed in order to avoid piston rod buckling.

Piston rods are not normally designed to absorb bending moments or loads which are perpendicular to the axis of piston rod motion. These additional loads can cause the piston rod to fail. If these types of additional loads are expected to be imposed on the piston rod, their magnitude should be made known to our engineering department.

The cylinder user should always make sure that the piston rod is securely attached to the machine member.

On occasion cylinders are ordered with double rods (a piston rod extended from both ends of the cylinder). In some cases a stop is threaded on to one of the piston rods and used as an external stroke adjuster. On occasions spacers are attached to the machine member connected to the piston rod and also used as a stroke adjuster. In both cases the stops will create a pinch point and the user should consider appropriate use of guards. If these external stops are not perpendicular to the mating contact surface, or if debris is trapped between the contact surfaces, a bending moment will be placed on the piston rod, which can lead to piston rod failure. An external stop will also negate the effect of cushioning and will subject the piston rod to impact loading. Those two (2) conditions can cause piston rod failure. Internal stroke adjusters are available with and without cushions. The use of external stroke adjusters should be reviewed with our engineering department.

The piston rod to piston and the stud to piston rod threaded connections are secured with an anaerobic adhesive. The strength of the adhesive decreases with increasing temperature. Cylinders which can be exposed to temperatures above +250°F (+121°C) are to be ordered with a non studded piston rod and a pinned piston to rod joint.

2.3 Cushions – Cushions should be considered for cylinder applications when the piston velocity is expected to be over 4 inches/second.

Cylinder cushions are normally designed to absorb the energy of a linear applied load. A rotating mass has considerably more energy than the same mass moving in a linear mode. Cushioning for a rotating mass application should be reviewed by our engineering department.

2.4 Cylinder Mountings – Some cylinder mounting configurations may have certain limitations such as but not limited to minimum stroke for side or foot mounting cylinders or pressure de-ratings for certain mounts. Carefully review the catalog for these types of restrictions.

Always mount cylinders using the largest possible high tensile alloy steel socket head cap screws that can fit in the cylinder mounting holes and torque them to the manufacturer's recommendations for their size.

2.5 Port Fittings – Hydraulic cylinders applied with meter out or deceleration circuits are subject to intensified pressure at piston rod end.

The rod end pressure is approximately equal to:

$$\frac{\text{operating pressure} \times \text{effective cap end area}}{\text{effective rod end piston area}}$$

Contact your connector supplier for the pressure rating of individual connectors.

3.0 Cylinder and Accessories Installation and Mounting

3.1 Installation

3.1.1 – Cleanliness is an important consideration, and cylinders are shipped with the ports plugged to protect them from contaminants entering the ports. These plugs should not be removed until the piping is to be installed. Before making the connection to the cylinder ports, piping should be thoroughly cleaned to remove all chips or burrs which might have resulted from threading or flaring operations.

⚠ PROP 65 WARNING **WARNING:** This product can expose you to chemicals including **Lead and Lead Compounds** which are known to the State of California to cause cancer and birth defects or other reproductive harm. For more information go to www.P65Warnings.ca.gov



3.1.2 – Cylinders operating in an environment where air drying materials are present such as fast-drying chemicals, paint, or weld splatter, or other hazardous conditions such as excessive heat, should have shields installed to prevent damage to the piston rod and piston rod seals.

3.1.3 – Proper alignment of the cylinder piston rod and its mating component on the machine should be checked in both the extended and retracted positions. Improper alignment will result in excessive rod gland and/or cylinder bore wear. On fixed mounting cylinders attaching the piston rod while the rod is retracted will help in achieving proper alignment.

3.1.4 – Sometimes it may be necessary to rotate the piston rod in order to thread the piston rod into the machine member. This operation must always be done with zero pressure being applied to either side of the piston. Failure to follow this procedure may result in loosening the piston to rod-threaded connection. In some rare cases the turning of the piston rod may rotate a threaded head and loosen it from the cylinder body. Confirm that this condition is not occurring. If it does, re-tighten the head firmly against the cylinder body.

For double rod cylinders it is also important that when attaching or detaching the piston rod from the machine member that the torque be applied to the piston rod end of the cylinder that is directly attaching to the machine member with the opposite end unrestrained. If the design of the machine is such that only the rod end of the cylinder opposite to where the rod attaches to the machine member can be rotated, consult the factory for further instructions.

3.2 Mounting Recommendations

3.2.1 – Always mount cylinders using the largest possible high tensile alloy steel socket head screws that can fit in the cylinder mounting holes and torque them to the manufacturer's recommendations for their size.

3.2.2 – Side-Mounted Cylinders – In addition to the mounting bolts, cylinders of this type should be equipped with thrust keys or dowel pins located so as to resist the major load.

3.2.3 – Tie Rod Mounting – Cylinders with tie rod mountings are recommended for applications where mounting space is limited. Nuts used for this mounting style should be torqued to the same value as the tie rods for that bore size.

3.2.4 – Flange Mount Cylinders – The controlled diameter of the rod gland extension on head end flange mount cylinders can be used as a pilot to locate the cylinders in relation to the machine. After alignment has been obtained, the flanges may be drilled for pins or dowels to prevent shifting.

3.2.5 – Trunnion Mountings – Cylinders require lubricated bearing blocks with minimum bearing clearances. Bearing blocks should be carefully aligned and rigidly mounted so the trunnions will not be subjected to bending moments. The rod end should also be pivoted with the pivot pin in line and parallel to axis of the trunnion pins.

3.2.6 – Clevis Mountings – Cylinders should be pivoted at both ends with centerline of pins parallel to each other. After cylinder is mounted, be sure to check to assure that the cylinder is free to swing through its working arc without interference from other machine parts.

4.0 Cylinder and Accessories Maintenance, Troubleshooting and Replacement

4.1 Storage – At times cylinders are delivered before a customer is ready to install them and must be stored for a period of time. When storage is required the following procedures are recommended.

4.1.1 – Store the cylinders in an indoor area which has a dry, clean and noncorrosive atmosphere. Take care to protect the cylinder from both internal corrosion and external damage.

4.1.2 – Whenever possible cylinders should be stored in a vertical position (piston rod up). This will minimize corrosion due to possible condensation which could occur inside the cylinder. This will also minimize seal damage.

4.1.3 – Port protector plugs should be left in the cylinder until the time of installation.

4.1.4 – If a cylinder is stored full of hydraulic fluid, expansion of the fluid due to temperature changes must be considered. Installing a check valve with free flow out of the cylinder is one method.

4.1.5 – When cylinders are mounted on equipment that is stored outside for extended periods, exposed unpainted surfaces, e.g. piston rod, must be coated with a rust-inhibiting compound to prevent corrosion.

4.2 Cylinder Trouble Shooting

4.2.1 – External Leakage

4.2.1.1 – Rod seal leakage can generally be traced to worn or damaged seals. Examine the piston rod for dents, gouges or score marks, and replace piston rod if surface is rough.

Rod seal leakage could also be traced to bearing wear. If clearance is excessive, replace rod bearing and seal. Rod seal leakage can also be traced to seal deterioration. If seals are soft or gummy or brittle, check compatibility of seal material with lubricant used if air cylinder, or operating fluid if hydraulic cylinder. Replace with seal material, which is compatible with these fluids. If the seals are hard or have lost elasticity, it is usually due to exposure to temperatures in excess of 165°F. (+74°C). Shield the cylinder from the heat source to limit temperature to 350°F. (+177°C.) and replace with fluorocarbon seals.

4.2.1.2 – Cylinder body seal leak can generally be traced to a loose head. Torque the head to manufacturer's recommendation for that bore size.

Excessive pressure can also result in cylinder body seal leak. Determine maximum pressure to rated limits. Replace seals and retorque head as in paragraph above. Excessive pressure can also result in cylinder body seal leak. Determine if the pressure rating of the cylinder has been exceeded. If so, bring the operating pressure down to the rating of the cylinder and have the head replaced.

Pinched or extruded cylinder body seal will also result in a leak. Replace cylinder body seal and retorque as in paragraph above.

Cylinder body seal leakage due to loss of radial squeeze which shows up in the form of flat spots or due to wear on the O.D. or I.D. – Either of these are symptoms of normal wear due to high cycle rate or length of service. Replace seals as per paragraph above.

4.2.2 – Internal Leakage

4.2.2.1 – Piston seal leak (by-pass) 1 to 3 cubic inches per minute leakage is considered normal for piston ring construction. Virtually no static leak with lipseal type seals on piston should be expected. Piston seal wear is a usual cause of piston seal leakage. Replace seals as required.

4.2.2.2 – With lipseal type piston seals excessive back pressure due to over-adjustment of speed control valves could be a direct cause of rapid seal wear. Contamination in a hydraulic system can result in a scored cylinder bore, resulting in rapid seal wear. In either case, replace piston seals as required.

4.2.2.3 – What appears to be piston seal leak, evidenced by the fact that the cylinder drifts, is not always traceable to the piston. To make sure, it is suggested that one side of the cylinder piston be pressurized and the fluid line at the opposite port be disconnected. Observe leakage. If none is evident, seek the cause of cylinder drift in other component parts in the circuit.

4.2.3 – Cylinder Fails to Move the Load

4.2.3.1 – Pneumatic or hydraulic pressure is too low. Check the pressure at the cylinder to make sure it is to circuit requirements.

4.2.3.2 – Piston Seal Leak – Operate the valve to cycle the cylinder and observe fluid flow at valve exhaust ports at end of cylinder stroke. Replace piston seals if flow is excessive.

4.2.3.3 – Cylinder is undersized for the load – Replace cylinder with one of a larger bore size.

4.3 Erratic or Chatter Operation

4.3.1 – Excessive friction at rod bearing or piston bearing due to load misalignment – Correct cylinder-to-load alignment.

4.3.2 – Cylinder sized too close to load requirements – Reduce load or install larger cylinder.

4.3.3 – Erratic operation could be traced to the difference between static and kinetic friction. Install speed control valves to provide a back pressure to control the stroke.

4.4 Cylinder Modifications, Repairs, or Failed Component

Cylinders as shipped from the factory are not to be disassembled and/or modified. If cylinders require modifications, these modifications must be done at company locations or by the Company's certified facilities. The Industrial Cylinder Division Engineering Department must be notified in the event of a mechanical fracture or permanent deformation of any cylinder component (excluding seals). This includes a broken piston rod, head, mounting accessory or any other cylinder component. The notification should include all operation and application details. This information will be used to provide an engineered repair that will prevent recurrence of the failure.

It is allowed to disassemble cylinders for the purpose of replacing seals or seal assemblies. However, this work must be done by strictly following all the instructions provided with the seal kits.



PROP 65 WARNING

WARNING: This product can expose you to chemicals including **Lead and Lead Compounds** which are known to the State of California to cause cancer and birth defects or other reproductive harm. For more information go to www.P65Warnings.ca.gov



The items described in this document and other documents and descriptions provided by Parker Hannifin Corporation, its subsidiaries and its authorized distributors ("Seller") are hereby offered for sale at prices to be established by Seller. This offer and its acceptance by any customer ("Buyer") shall be governed by all of the following Terms and Conditions. Buyer's order for any item described in its document, when communicated to Seller verbally, or in writing, shall constitute acceptance of this offer. All goods, services or work described will be referred to as "Products".

1. Terms. All sales of Products by Seller are expressly conditioned upon, and will be governed by the acceptance of, these Terms. These Terms are incorporated into any Quote provided by Seller to Buyer. Buyer's order for any Products whether communicated to Seller verbally, in writing, by electronic data interface or other electronic commerce, shall constitute acceptance of these Terms. Seller objects to any contrary or additional terms or conditions of Buyer. Reference in Seller's order acknowledgement to Buyer's purchase order or purchase order number shall in no way constitute an acceptance of any of Buyer's terms or conditions of purchase. No modification to these Terms will be binding on Seller unless agreed to in writing and signed by an authorized representative of Seller.

2. Price; Payment. The Products set forth in the Quote are offered for sale at the prices indicated in the Quote. Unless otherwise specifically stated in the Quote, prices are valid for thirty (30) days and do not include any sales, use, or other taxes or duties. Seller reserves the right to modify prices at any time to adjust for any raw material price fluctuations. Unless otherwise specified by Seller, all prices are F.C.A. Seller's facility (INCOTERMS 2020). All sales are contingent upon credit approval and full payment for all purchases is due thirty (30) days from the date of invoice (or such date as may be specified in the Quote). Unpaid invoices beyond the specified payment date incur interest at the rate of 1.5% per month or the maximum allowable rate under applicable law.

3. Shipment; Delivery; Title and Risk of Loss. All delivery dates are approximate, and Seller is not responsible for damages resulting from any delay. Regardless of the manner of shipment, delivery occurs and title and risk of loss or damage pass to Buyer, upon placement of the Products with the carrier at Seller's facility. Unless otherwise agreed prior to shipment and for domestic delivery locations only, Seller will select and arrange, at Buyer's sole expense, the carrier and means of delivery. When Seller selects and arranges the carrier and means of delivery, freight and insurance costs for shipment to the designated delivery location will be prepaid by Seller and added as a separate line item to the invoice. Buyer shall be responsible for any additional shipping charges incurred by Seller due to Buyer's acts or omissions. Buyer shall not return or repackage any Products without the prior written authorization from Seller, and any return shall be at the sole cost and expense of Buyer.

4. Warranty. The warranty for the Products is as follows: (i) Goods are warranted against defects in material or workmanship for a period of eighteen (18) months from the date of delivery or 2,000 hours of use, whichever occurs first; (ii) Services shall be performed in accordance with generally accepted practices and using the degree of care and skill that is ordinarily exercised and customary in the field to which the Services pertain and are warranted for a period of six (6) months from the date of completion of the Services; and (iii) Software is only warranted to perform in accordance with applicable specifications provided by Seller to Buyer for ninety (90) days from the date of delivery or, when downloaded by a Buyer or end-user, from the date of the initial download. All prices are based upon the exclusive limited warranty stated above, and upon the following disclaimer: **EXEMPTION CLAUSE; DISCLAIMER OF WARRANTY, CONDITIONS, REPRESENTATIONS: THIS WARRANTY IS THE SOLE AND ENTIRE WARRANTY, CONDITION, AND REPRESENTATION, PERTAINING TO PRODUCTS. SELLER DISCLAIMS ALL OTHER WARRANTIES, CONDITIONS, AND REPRESENTATIONS, WHETHER STATUTORY, EXPRESS OR IMPLIED, INCLUDING BUT NOT LIMITED TO THOSE RELATING TO DESIGN, NON-INFRINGEMENT, MERCHANTABILITY, AND FITNESS FOR A PARTICULAR PURPOSE. SELLER DOES NOT WARRANT THAT THE SOFTWARE IS ERROR-FREE OR FAULT-TOLERANT, OR THAT BUYER'S USE THEREOF WILL BE SECURE OR UNINTERRUPTED. UNLESS OTHERWISE AUTHORIZED IN WRITING BY SELLER, THE SOFTWARE SHALL NOT BE USED IN CONNECTION WITH HAZARDOUS OR HIGH RISK ACTIVITIES OR ENVIRONMENTS. EXCEPT AS EXPRESSLY STATED HEREIN, ALL PRODUCTS ARE PROVIDED "AS IS".**

5. Claims; Commencement of Actions. Buyer shall promptly inspect all Products upon receipt. No claims for shortages will be allowed unless reported to Seller within ten (10) days of delivery. Buyer shall notify Seller of any alleged breach of warranty within thirty (30) days after the date the non-conformance is or should have been discovered by Buyer. Any claim or action against Seller based upon breach of contract or any other theory, including tort, negligence, or otherwise must be commenced within twelve (12) months from the date of the alleged breach or other alleged event, without regard to the date of discovery.

6. LIMITATION OF LIABILITY. IN THE EVENT OF A BREACH OF WARRANTY, SELLER WILL, AT ITS OPTION, REPAIR OR REPLACE THE NON-CONFORMING PRODUCT, RE-PERFORM THE SERVICES, OR REFUND THE PURCHASE PRICE PAID WITHIN A REASONABLE PERIOD OF TIME. **IN NO EVENT IS SELLER LIABLE FOR ANY SPECIAL, INDIRECT, INCIDENTAL OR CONSEQUENTIAL DAMAGES INCLUDING ANY LOSS OF REVENUE OR PROFITS, WHETHER BASED IN CONTRACT, TORT OR OTHER LEGAL THEORY. IN NO EVENT SHALL SELLER'S LIABILITY UNDER ANY CLAIM MADE BY BUYER EXCEED THE PURCHASE PRICE PAID FOR THE PRODUCTS.**

7. Confidential Information. Buyer acknowledges and agrees that any technical, commercial, or other confidential information of Seller, including, without limitation, pricing, technical drawings or prints and/or part lists, which has been or will be disclosed, delivered or made available, whether directly or indirectly, to Buyer ("Confidential Information"), has been and will be received in confidence and will remain the property of Seller. Buyer further agrees that it will not use Seller's Confidential Information for any purpose other than for the benefit of Seller.

8. Loss to Buyer's Property. Any tools, patterns, materials, equipment or information furnished by Buyer or which are or become Buyer's property ("Buyer's Property"), will be considered obsolete and may be destroyed by Seller after two (2) consecutive years have elapsed without Buyer ordering the Products manufactured using Buyer's Property. Furthermore, Seller shall not be responsible for any loss or damage to Buyer's Property while it is in Seller's possession or control.

9. Special Tooling. "Special Tooling" includes but is not limited to tools, jigs, fixtures and associated manufacturing equipment acquired or necessary to manufacture Goods. Seller may impose a tooling charge for any Special Tooling. Such Special Tooling shall be and remain Seller's property notwithstanding payment of any charges by Buyer. In no event will Buyer acquire any interest in the Special Tooling, even if such Special Tooling has been specially converted or adapted for manufacture of Goods for Buyer and notwithstanding any charges paid by Buyer. Unless otherwise agreed, Seller has the right to alter, discard or otherwise dispose of any Special Tooling or other property owned by Seller in its sole discretion at any time.

10. Security Interest. To secure payment of all sums due from Buyer, Seller retains a security interest in all Products delivered to Buyer and, Buyer's acceptance of these Terms is deemed to be a Security Agreement under the Uniform Commercial Code. Buyer authorizes Seller as its attorney to execute and file on Buyer's behalf all documents Seller deems necessary to perfect Seller's security interest.

11. User Responsibility. Buyer, through its own analysis and testing, is solely responsible for making the final selection of the Products and assuring that all performance, endurance, maintenance, safety and warning requirements of the application of the Products are met. Buyer must analyze all aspects of the application and follow applicable industry standards, specifications, and any technical information provided with the Quote or the Products, such as Seller's instructions, guides and specifications. If Seller provides options of or for Products based upon data or specifications provided by Buyer, Buyer is responsible for determining that such data and specifications are suitable and sufficient for all applications and reasonably foreseeable uses of the Products. In the event Buyer is not the end-user of the Products, Buyer will ensure such end-user complies with this paragraph.

12. Use of Products, Indemnity by Buyer. Buyer shall comply with all instructions, guides and specifications provided by Seller with the Quote or the Products. Unauthorized Uses. If Buyer uses or resells the Products in any way prohibited by Seller's instructions, guides or specifications, or Buyer otherwise fails to comply with Seller's

instructions, guides and specifications, Buyer acknowledges that any such use, resale, or non-compliance is at Buyer's sole risk. Further, Buyer shall indemnify, defend, and hold Seller harmless from any losses, claims, liabilities, damages, lawsuits, judgments and costs (including attorney fees and defense costs), whether for personal injury, property damage, intellectual property infringement or any other claim, arising out of or in connection with: (a) improper selection, design, specification, application, or any misuse of Products; (b) any act or omission, negligent or otherwise, of Buyer; (c) Seller's use of patterns, tools, equipment, plans, drawings, designs, specifications or other information or things furnished by Buyer; (d) damage to the Products from an external cause, repair or attempted repair by anyone other than Seller, failure to follow instructions, guides and specifications provided by Seller, use with goods not provided by Seller, or opening, modifying, deconstructing, tampering with or repackaging the Products; or (e) Buyer's failure to comply with these Terms. Seller shall not indemnify Buyer under any circumstance except as otherwise provided in these Terms.

13. Cancellations and Changes. Buyer may not cancel or modify, including but not limited to movement of delivery dates for the Products, any order for any reason except with Seller's written consent and upon terms that will indemnify, defend and hold Seller harmless against all direct, incidental and consequential loss or damage and any additional expense. Seller, at any time, may change features, specifications, designs and availability of Products.

14. Limitation on Assignment. Buyer may not assign its rights or obligations without the prior written consent of Seller.

15. Force Majeure. Seller is not liable for delay or failure to perform any of its obligations by reason of events or circumstances beyond its reasonable control. Such circumstances include without limitation: accidents, labor disputes or stoppages, government acts or orders, acts of nature, pandemics, epidemics, other widespread illness, or public health emergency, delays or failures in delivery from carriers or suppliers, shortages of materials, war (whether declared or not) or the serious threat of same, riots, rebellions, acts of terrorism, fire or any reason whether similar to the foregoing or otherwise. Seller will resume performance as soon as practicable after the event of force majeure has been removed. All delivery dates affected by force majeure shall be tolled for the duration of such force majeure and rescheduled for mutually agreed dates as soon as practicable after the force majeure condition ceases to exist. Force majeure shall not include financial distress, insolvency, bankruptcy, or other similar conditions affecting one of the parties, affiliates and/or sub-contractors.

16. Waiver and Severability. Failure to enforce any provision of these Terms will not invalidate that provision; nor will any such failure prejudice either party's right to enforce that provision in the future. Invalidation of any provision of these Terms shall not invalidate any other provision herein and, the remaining provisions will remain in full force and effect.

17. Termination. Seller may terminate any agreement governed by or arising from these Terms for any reason and at any time by giving Buyer thirty (30) days prior written notice. Seller may immediately terminate, in writing, if Buyer: (a) breaches any provision of these Terms, (b) becomes or is deemed insolvent, (c) appoints or has appointed a trustee, receiver or custodian for all or any part of Buyer's property, (d) files a petition for relief in bankruptcy on its own behalf, or one is filed against Buyer by a third party, (e) makes an assignment for the benefit of creditors; or (f) dissolves its business or liquidates all or a majority of its assets.

18. Ownership of Software. Seller retains ownership of all Software supplied to Buyer hereunder. In no event shall Buyer obtain any greater right in and to the Software than a right in the nature of a license limited to the use thereof and subject to compliance with any other terms provided with the Software.

19. Indemnity for Infringement of Intellectual Property Rights. Seller is not liable for infringement of any patents, trademarks, copyrights, trade dress, trade secrets or similar rights ("Intellectual Property Rights") except as provided in this Section. Seller will defend at its expense and will pay the cost of any settlement or damages awarded in an action brought against Buyer based on a third party claim that one or more of the Products sold hereunder infringes the Intellectual Property Rights of a third party in the country of delivery of the Products by Seller to Buyer. Seller's obligation to defend and indemnify Buyer is contingent on Buyer notifying Seller within ten (10) days after Buyer becomes aware of any such claim, and Seller having sole control over the defense of the claim including all negotiations for settlement or compromise. If one or more Products sold hereunder is subject to such a claim, Seller may, at its sole expense and option, procure for Buyer the right to continue using the Products, replace or modify the Products so as to render them non-infringing, or offer to accept return of the Products and refund the purchase price less a reasonable allowance for depreciation. Seller has no obligation or liability for any claim of infringement: (i) arising from information provided by Buyer; or (ii) directed to any Products provided hereunder for which the designs are specified in whole or part by Buyer; or (iii) resulting from the modification, combination or use in a system of any Products provided hereunder. The foregoing provisions of this Section constitute Seller's sole and exclusive liability and Buyer's sole and exclusive remedy for claims of infringement of Intellectual Property Rights.

20. Governing Law. These Terms and the sale and delivery of all Products are deemed to have taken place in, and shall be governed and construed in accordance with, the laws of the State of Ohio, as applicable to contracts executed and wholly performed therein and without regard to conflicts of laws principles. Buyer irrevocably agrees and consents to the exclusive jurisdiction and venue of the courts of Cuyahoga County, Ohio with respect to any dispute, controversy or claim arising out of or relating to the sale and delivery of the Products.

21. Entire Agreement. These Terms, along with the terms set forth in the main body of any Quote, forms the entire agreement between the Buyer and Seller and constitutes the final, complete and exclusive expression of the terms of sale and purchase. In the event of a conflict between any term set forth in the main body of a Quote and these Terms, the terms set forth in the main body of the Quote shall prevail. All prior or contemporaneous written or oral agreements or negotiations with respect to the subject matter shall have no effect. These Terms may not be modified unless in writing and signed by an authorized representative of Seller.

22. Compliance with Laws. Buyer agrees to comply with all applicable laws, regulations, and industry and professional standards, including those of the United States of America, and the country or countries in which Buyer may operate, including without limitation the U.S. Foreign Corrupt Practices Act ("FCPA"), the U.S. Anti-Kickback Act ("Anti-Kickback Act"), U.S. and E.U. export control and sanctions laws ("Export Laws"), the U.S. Food and Drug Administration ("FDA"), and the rules and regulations promulgated by the U.S. Food and Drug Administration ("FDA"), each as currently amended. Buyer agrees to indemnify, defend, and hold harmless Seller from the consequences of any violation of such laws, regulations and standards by Buyer, its employees or agents. Buyer acknowledges that it is familiar with all applicable provisions of the FCPA, the Anti-Kickback Act, Export Laws, the FDA and the FDA and certifies that Buyer will adhere to the requirements thereof and not take any action that would make Seller violate such requirements. Buyer represents and agrees that Buyer will not make any payment or give anything of value, directly or indirectly, to any governmental official, foreign political party or official thereof, candidate for foreign political office, or commercial entity or person, for any improper purpose, including the purpose of influencing such person to purchase Products or otherwise benefit the business of Seller. Buyer further represents and agrees that it will not receive, use, service, transfer or ship any Products from Seller in a manner or for a purpose that violates Export Laws or would cause Seller to be in violation of Export Laws. Buyer agrees to promptly and reliably provide Seller all requested information or documents, including end-user statements and other written assurances, concerning Buyer's ongoing compliance with Export Laws. 08/2020

 **PROP 65 WARNING** **WARNING:** This product can expose you to chemicals including **Lead and Lead Compounds** which are known to the State of California to cause cancer and birth defects or other reproductive harm. For more information go to www.P65Warnings.ca.gov



Parker Hannifin Corporation

Cylinder Division

500 South Wolf Road

Des Plaines, IL 60016

phone (847) 298-2400

fax (800) 892-1008

www.parker.com/cylinder

