

Parker Heavy Duty Hydraulic Cylinders

Series 2H

Exclusive with the Parker Stepped Cushion for increased performance and productivity

- Faster cycle time
- Reduced hydraulic shock
- Reduced machine noise
- Lower machine maintenance



- Heavy Duty Service – Industrial Tie-Rod Construction
- Nominal Pressure – 3000 PSI
- Standard Bore Sizes – 1-1/2" through 6"
- Piston Rod Diameters – 5/8" through 4"
- 18 Standard Mounting Styles

For Cylinder Division Plant Locations – See Page II.

The heavy-duty hydraulic cylinder with features only Parker can promise – and deliver!

Series 2H cylinders keep on performing like you expect from Parker — producing more power per pound, more power per dollar — over millions of trouble-free cycles. Everything you need for reliable 3,000 psi performance. Patented “Jewel” rod gland for longer life and lower operating costs. Chrome-plated, case hardened piston rods. Rod end studs of high yield-strength steel, with rolled threads for added strength. Tie rods with rolled threads and steel nuts. Floating cushions with float-check action and positive metal-to-metal seal. And every Parker cylinder is *individually* tested before it leaves our plant.



For additional information – call your local Parker Cylinder Distributor.

Series 2H Heavy Duty Hydraulic Cylinders

Specifications/ Mountings

Standard Specifications

- Heavy Duty Service – ANSI/(NFPA) T3.6.7R2 - 1996 Specifications and Mounting Dimension Standards
- Standard Construction – Square Head – Tie Rod Design
- Nominal Pressure – 3000 P.S.I.*
- Standard Fluid – Hydraulic Oil
- Standard Temperature – -10° F to +165° F**
- Bore Sizes – 1 1/2" through 6" (Larger sizes available)

- Piston Rod Diameter – 5/8" through 4"
- Mounting Styles – 18 standard styles at various application ratings
- Strokes – Available in any practical stroke length
- Cushions – Optional at either end or both ends of stroke. "Float Check" at cap end.
- Rod Ends – Three Standard Choices – Specials to Order

*If hydraulic operating pressure exceeds 3000 P.S.I., send application data for engineering evaluation and recommendation. See section C, page 84 for actual design factors.

** See section C, page 83 for higher temperature service.

In line with our policy of continuing product improvement, specifications in this catalog are subject to change.

Note: Series 2H Hydraulic Cylinders fully meet ANSI/(NFPA) T3.6.7R2 - 1996 Specifications and Mounting Dimension Standards for Square Head Industrial Fluid Power Cylinders.

Available Mounting Styles

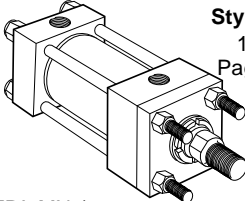
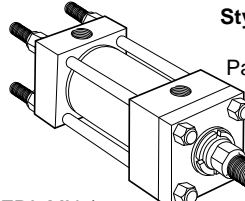
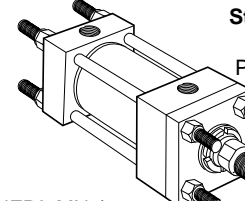
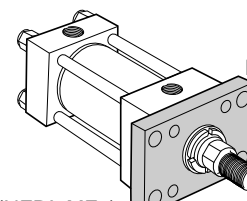
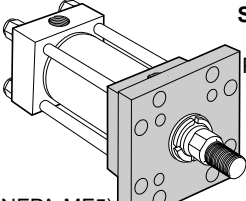
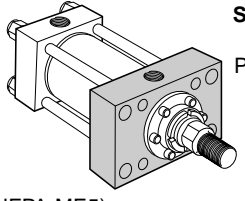
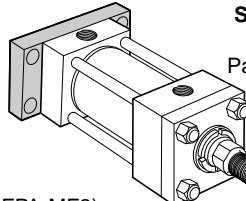
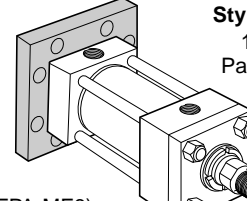
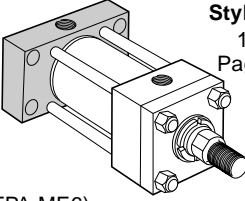
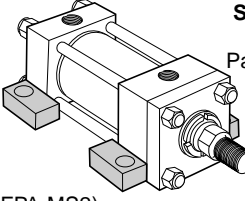
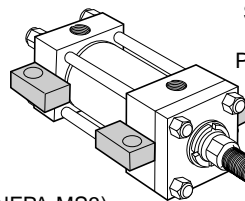
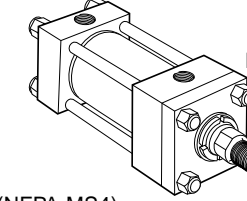
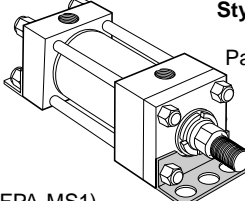
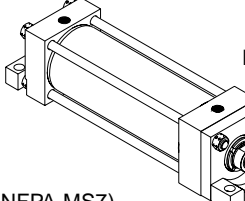
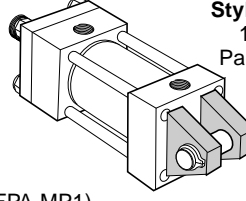
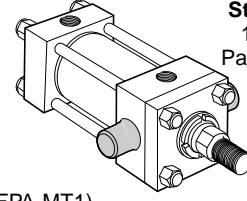
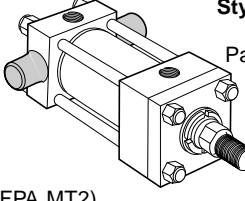
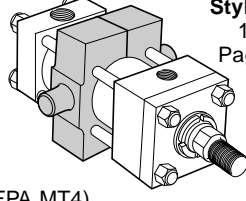
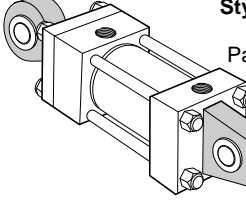
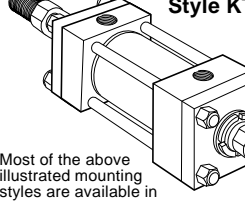
<p>Tie Rods Extended Head End</p>  <p>Style TB 1 1/2-6" Page 44</p> <p>(NFPA MX3)</p>	<p>Tie Rods Extended Cap End</p>  <p>Style TC 1 1/2-6" Page 44</p> <p>(NFPA MX2)</p>	<p>Tie Rods Extended Both Ends</p>  <p>Style TD 1 1/2-6" Page 44</p> <p>(NFPA MX1)</p>	<p>Head Rectangular Flange</p>  <p>Style J 1 1/2-6" Page 46</p> <p>(NFPA MF1)</p>
<p>Head Square Flange</p>  <p>Style JB 1 1/2-6" Page 46</p> <p>(NFPA MF5)</p>	<p>Head Rectangular</p>  <p>Style JJ 1 1/2-6" Page 46</p> <p>(NFPA ME5)</p>	<p>Cap Rectangular Flange</p>  <p>Style H 1 1/2-6" Page 48</p> <p>(NFPA MF2)</p>	<p>Cap Square Flange</p>  <p>Style HB 1 1/2-6" Page 48</p> <p>(NFPA MF6)</p>
<p>Cap Rectangular</p>  <p>Style HH 1 1/2-6" Page 48</p> <p>(NFPA ME6)</p>	<p>Side Lug</p>  <p>Style C 1 1/2-6" Page 50</p> <p>(NFPA MS2)</p>	<p>Centerline Lugs</p>  <p>Style E 1 1/2-6" Page 50</p> <p>(NFPA MS3)</p>	<p>Side Tapped</p>  <p>Style F 1 1/2-6" Page 50</p> <p>(NFPA MS4)</p>
<p>Side End Angles</p>  <p>Style CB 1 1/2-6" Page 52</p> <p>(NFPA MS1)</p>	<p>Side End Lugs</p>  <p>Style G 1 1/2-6" Page 52</p> <p>(NFPA MS7)</p>	<p>Cap Fixed Clevis</p>  <p>Style BB 1 1/2-6" Page 52</p> <p>(NFPA MP1)</p>	<p>Head Trunnion</p>  <p>Style D 1 1/2-6" Page 54</p> <p>(NFPA MT1)</p>
<p>Cap Trunnion</p>  <p>Style DB 1 1/2-6" Page 54</p> <p>(NFPA MT2)</p>	<p>Intermediate Fixed Trunnion</p>  <p>Style DD 1 1/2-6" Page 54</p> <p>(NFPA MT4)</p>	<p>Spherical Bearing</p>  <p>Style SB 1 1/2-6" Page 56</p>	<p>Double Rod Cylinders</p>  <p>Style KT Shown 1 1/2-6"</p> <p>Most of the above illustrated mounting styles are available in double rod cylinders. See Catalog Page 58.</p>

For Cylinder Division Plant Locations – See Page II.

The inside story on why series 2H is your best choice in heavy duty hydraulic cylinders

Primary Seal – New TS-2000 Rod Seal is a proven leakproof design – completely self-compensating and self-relieving to withstand variations and conform to mechanical deflection that may occur.

Piston Rod Stud – Furnished on 2" diameter rods and smaller when standard style #4 rod end threads are required or on 1 3/8" diameter rods and smaller when style #8 threads are required. Also available in 2 times the catalog "A" dimension length. Studs have rolled threads and are made from high strength steel. Anaerobic adhesive is used to permanently lock the stud to the piston rod.

"Jewel" Rod Gland Assembly – Externally removable without cylinder disassembly. Long bearing surface is inboard of the seals, assuring positive lubrication from within the cylinder. An "O" ring is used as a seal between gland and head, and also serves as a prevailing torque-type lock.

Secondary Seal – Double-Service Wiperseal® (Hannifin Patent #2907596) – wipes clean any oil film adhering to the rod on the extend stroke and cleans the rod on the return stroke.

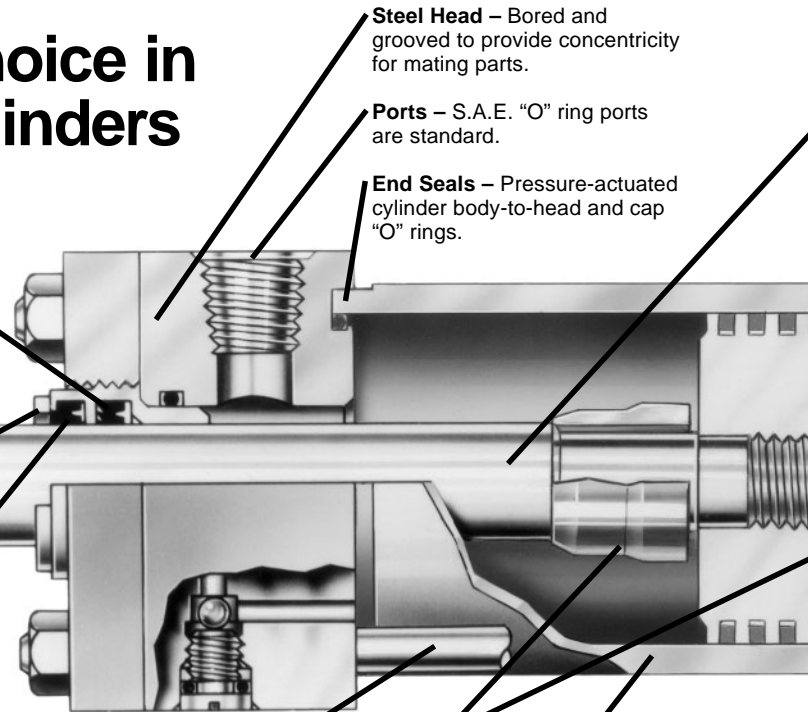
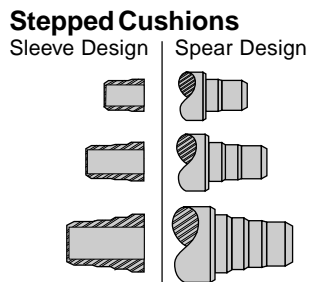

Steel Head – Bored and grooved to provide concentricity for mating parts.

Ports – S.A.E. "O" ring ports are standard.

End Seals – Pressure-actuated cylinder body-to-head and cap "O" rings.

High Strength Tie Rods – Made from 100,000 psi minimum yield steel with rolled threads for added strength.

The Cylinder Body – Heavy-wall steel tubing, honed to a micro finish bore.

Adjustable Floating Stepped Cushions – For maximum performance – economical and flexible for even the most demanding applications – provides superior performance in reducing shock. Cushions are optional and can be supplied at head end, cap end, or both ends without change in envelope or mounting dimensions.

Parker's New, Exclusive Stepped floating cushions combine the best features of known cushion technology.

Deceleration devices or built-in "cushions" are optional and can be supplied at head end, cap end, or both ends without change in envelope or mounting dimensions. Parker cylinder cushions are a stepped design and combine the best features of known cushion technology.

Standard straight or tapered cushions have been used in industrial cylinders over a very broad range of applications. Parker research has found that both designs have their limitations.

As a result, Parker has taken a new approach in cushioning of industrial hydraulic cylinders and for specific load and velocity conditions have been able to obtain deceleration curves that come very close to the ideal. The success lies in a stepped sleeve or spear concept where the steps are calculated to approximate theoretical orifice areas curves.

In the cushion performance chart, pressure traces show the results of typical orifice flow conditions. Tests of a three-step sleeve or spear show three pressure pulses coinciding with the steps. The deceleration cushion plunger curves shape comes very close to being theoretical, with the exception of the last 1/2 inch of

travel. This is a constant shape in order to have some flexibility in application. The stepped cushion design shows reduced pressure peaks for most load and speed conditions, with comparable reduction of objectionable stopping forces being transmitted to the load and the support structure.

All Parker Hannifin cushions are adjustable.

The Series 2H cylinder design incorporates the longest cushion sleeve and cushion spear that can be provided in the standard envelope without decreasing the rod bearing and piston bearing strengths.

(1) When a cushion is specified at the head end:

- A self-centering stepped sleeve is furnished on the piston rod assembly.
- A needle valve is provided that is flush with the side of the

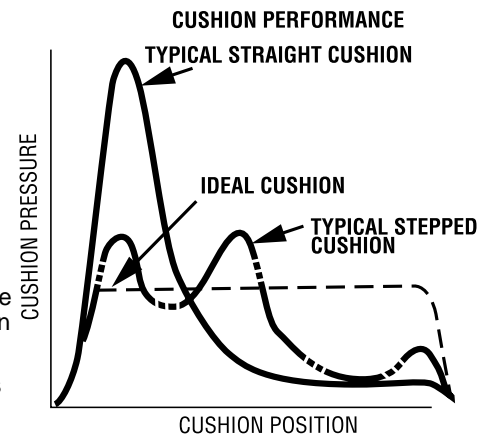

For additional information – call your local Parker Cylinder Distributor.

Piston Rod – Medium carbon steel, induction case-hardened to 54 Rc, hard chrome-plated and polished to 10 RMS finish. Piston rods are made from 90,000 to 100,000 psi minimum yield material in 5/8" through 4" diameters. Larger diameters vary between 57,000 and 90,000 psi minimum material, depending on rod diameter. The piston thread equals the catalog style #4 rod end thread for each rod diameter to assure proper piston-to-rod thread strength. Two wrench flats are provided for rod end attachment.

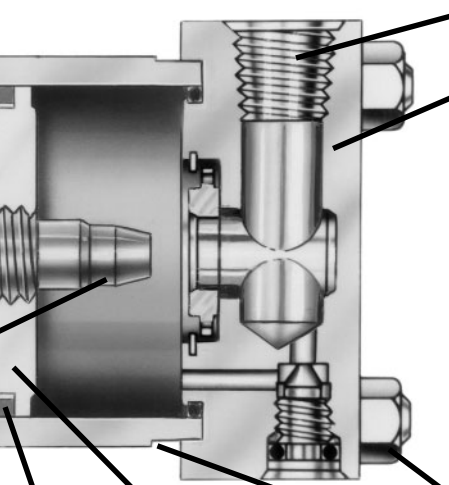

Ports – S.A.E. "O" ring ports are standard.

Steel Cap – Bored and grooved to provide concentricity for mating parts.

Optional Ports

Ports – N.P.T.F. ports are optional at no extra charge. Oversize N.P.T.F. and S.A.E. ports are available at extra charge.

Seals – Buna-N (Nitrile) seals are standard.

Fluorocarbon Seals – Optional at extra charge.

Alloy Steel Tie Rod Nuts

Align-A-Groove – (Patent #3043639) – A 3/16" wide surface machined at each end of the cylinder body. Makes precise mounting quick and easy.

One-Piece Nodular Iron Piston – The wide piston surface contacting cylinder bore reduces bearing loads. Anaerobic adhesive is used to permanently lock and seal the piston to the rod.

Step Cut Iron Piston Rings are standard.

The exclusive "Jewel" gland gives you longer cylinder life, better performance and lower costs.



An extra-long inboard bearing surface insures lubrication from within the cylinder. Outboard of the bearing surface are two leakproof seals – The TS-2000 and Wiperseal. The serrated TS-2000 (primary seal) is completely self-compensating and self-relieving. It adjusts to mechanical deflections or any pressure variation from near-zero to rated operating pressure. The result is positive, no-leak sealing – regardless of conditions.

The Wiperseal does double duty. On the advance stroke, it acts as a secondary pressure seal. On the return, it wipes away any dirt on the rod. This means less wear on bearing surfaces and internal parts. Longer life for working parts. And, less loss of fluid. Plus, you can replace a "Jewel" gland without removing the tie rods or the retainer. Just a few twists with a spanner wrench does the job.

Optional Pistons

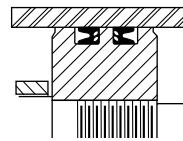

Lipseal® Piston – Optional at no extra charge. Zero leakage under static conditions for hydraulic pressures up to 3000 psi. Seals are self-compensating to conform to variations in pressure, mechanical deflection, and wear. Back-up washers prevent extrusion.

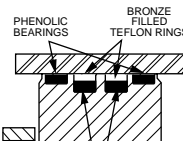

Hi Load Piston – Optional at extra charge. Includes wear rings and bronze-filled PTFE seals. Two wear rings serve as bearings which deform radially under side-loading, enabling the load to be spread over a larger area and reduce unit loading. Bronze-filled PTFE seals are designed for extrusion-free, leak-proof service and longer cylinder life than the lipseal type piston.

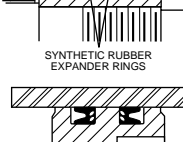

Nut Retained Piston – Optional at extra charge.

head even when wide open. It may be identified by the fact that it is socket-keyed. It is located on side number 2, in all mounting styles except D, DB, DD, JJ, HH and E. In these styles it is located on side number 3.

- c. On 6" bore and larger cylinders (except for 2 1/2" bore with code 2 rod), a springless check valve is provided that is also flush with the side of the head and is mounted adjacent to the needle valve except on mounting style C, where it is mounted opposite the needle valve. It may be identified by the fact that it is slotted.
- d. On 1 1/2" - 5" bore cylinders a slotted sleeve design is used in place of the check valve.
- e. 1 1/2" - 2 1/2" bore cylinders use a cartridge style needle valve (see Figure A).

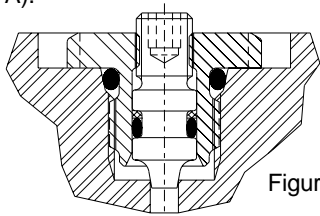

Figure A

- (2) When a cushion is specified at the cap end:
 - a. A cushion stepped spear is provided on the piston rod.

- b. A "float check" self-centering bushing is provided which incorporates a large flow check valve for fast "out-stroke" action.
- c. A socket-keyed needle valve is provided that is flush with the side of the cap when wide open. It is located on side number 2 in all mounting styles except D, DB, DD, JJ, HH and E. In these styles it is located on side number 3.

Cushion Length

Cyl. Bore In.	Rod Dia. In.	Rod No.	Cushion Length - Inch	
			Head*	Cap
1 1/2	5/8	1	1 1/8	1 3/16
	1	2	1 1/8	1 3/16
2	1	1	1 1/8	1 1/8
	1 3/8	2	1 1/8	1 1/8
2 1/2	1	1	1 1/8	1 1/8
	1 3/4	2	1 1/8	1 1/8
3 1/4	1 3/8	1	1 3/8	1 5/16
	2	2	1 1/16	1 5/16
4	1 3/4	1	1 3/8	1 1/4
	2 1/2	2	1 1/16	1 1/4
5	2	1	1 1/16	1 1/8
	3 1/2	2	1 1/16	1 1/8

Cyl. Bore In.	Rod Dia. In.	Rod No.	Cushion Length - Inch	
			Head*	Cap
6	2 1/2	1	1 5/16	1 1/2
	4	2	1 5/16	1 1/2
7	3	1	1 13/16	1 15/16
	5	2	1 11/16	1 15/16
8	3 1/2	1	2 1/16	2
	5 1/2	2	1 15/16	2

*Head end cushions for rod diameters not listed have cushion lengths with the limits shown.

For Cylinder Division Plant Locations – See Page II.



Tie Rod Mountings
1½" to 6" Bore Sizes

Series 2H Heavy Duty Hydraulic Cylinders

Tie Rods Extended Head End
Style TB
(NFFA Style MX3)

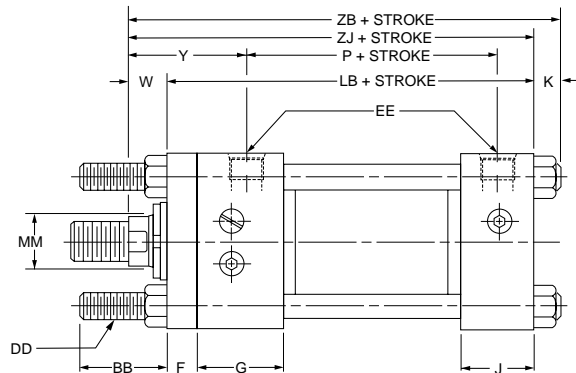
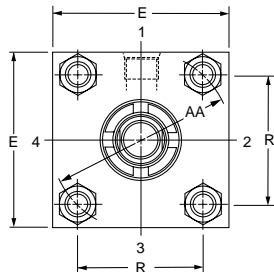
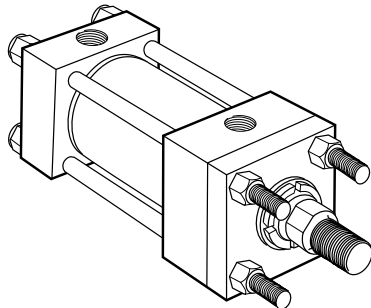

Tie Rods Extended Cap End
Style TC
(NFFA Style MX2)

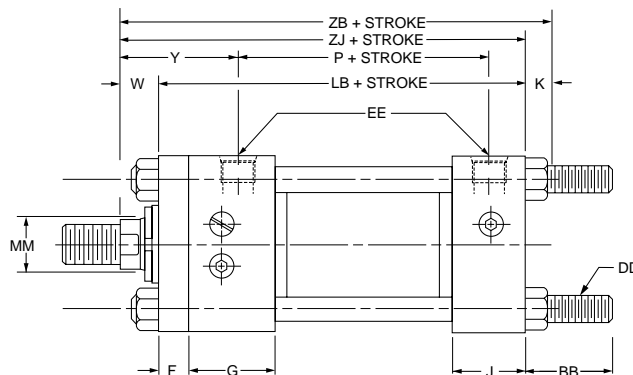
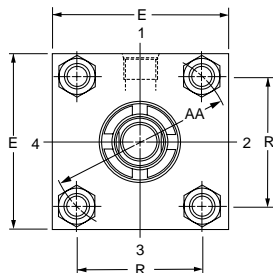
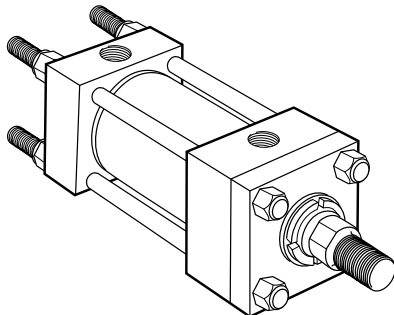

Tie Rods Extended Both Ends
Style TD
(NFFA Style MX1)

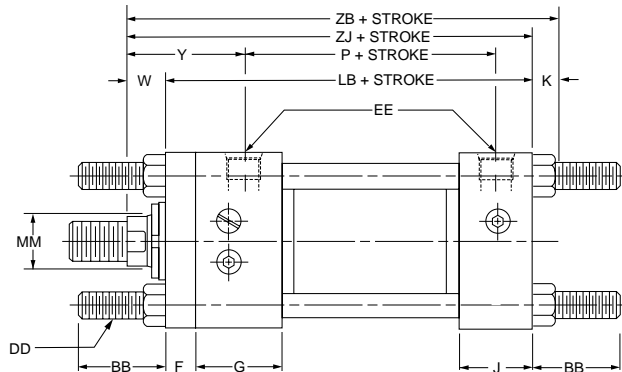
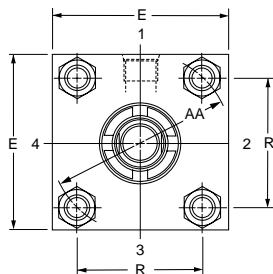
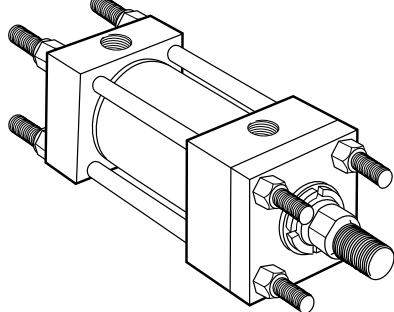

Basic Mounting (T) — NFFA MX0 — Not shown is no tie rod extended and can be supplied upon request.

Rod End Dimensions — see table 2

Thread Style 4
(NFFA Style SM)
Small Male

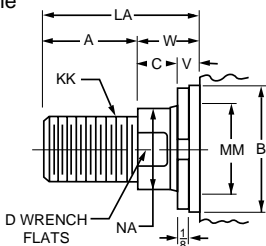

A high strength rod end stud is supplied on thread style 4 through 2" diameter rods and on thread style 8 through 1½" diameter rods. Larger sizes or special rod ends are cut threads. Style 4 rod ends are recommended where the workpiece is secured against the rod shoulder.

Thread Style 8
(NFFA Style IM)
Intermediate Male

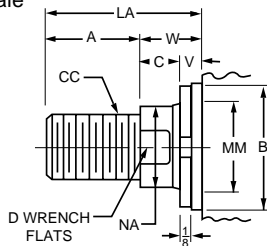

When the workpiece is not shouldered, style 4 rod ends are recommended through 2" piston rod diameters and style 8 rod ends are recommended on larger diameters. Use style 9 for applications where female rod end threads are required. If rod end is not specified, style 4 will be supplied.

Thread Style 9
(NFFA Style SF)
Small Female

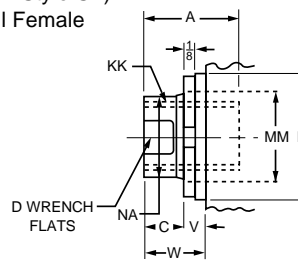

"Special" Thread Style 3

Special thread, extension, rod eye, blank, etc., are also available.

To order, specify "Style 3" and give desired dimensions for CC or KK, A and LA. If otherwise special, furnish dimensioned sketch.

For additional information — call your local Parker Cylinder Distributor.

Series 2H Heavy Duty Hydraulic Cylinders

Tie Rod Mountings
1½" to 6" Bore Sizes

Table 1—Envelope and Mounting Dimensions

Bore	AA	BB	DD	E	EE		F	G	J	K	R	Add Stroke	
					NPTF [⊖]	SAE★						LB	P
1½	2.3	1⅜	⅜-24	2½	1/2	10	⅜	1¾	1½	⅜	1.63	5	27/8
2	2.9	1⅜ ₁₆	1/2-20	3	1/2	10	5/8	1¾	1½	7/16	2.05	5¼	27/8
2½	3.6	1⅜ ₁₆	1/2-20	3½	1/2	10	5/8	1¾	1½	7/16	2.55	5⅜	3
3¼	4.6	25/16	5/8-18	4½	¾	12	¾	2	1¾	9/16	3.25	6¼	3½
4	5.4	25/16	5/8-18	5	¾	12	7/8	2	1¾	9/16	3.82	65/8	3¾
5	7.0	33/16	7/8-14	6½	¾	12	7/8	2	1¾	13/16	4.95	7⅞	4¼
6	8.1	35/8	1-14	7½	1	16	1	2¼	2¼	7/8	5.73	83/8	47/8

★ SAE straight thread ports are standard and are indicated by port number.
[⊖] NPTF ports are available at no extra charge.

Table 2—Rod Dimensions

Bore	Rod No.	Rod Dia. MM	Thread		Rod Extensions and Pilot Dimensions								Add Stroke		
			Style 8 CC	Style 4 & 9 KK	A	+0.000 -0.002 B	C	D	LA	NA	V	W	Y	ZB	ZJ
1½	1(Std.)	5/8	1/2-20	7/16-20	¾	1.124	⅜	1/2	1⅜	9/16	1/4	5/8	2	6	55/8
	2	1	7/8-14	¾-16	1⅞	1.499	1/2	7/8	2⅞	15/16	1/2	1	23/8	63/8	6
2	1(Std.)	1	7/8-14	¾-16	1⅞	1.499	1/2	7/8	17/8	15/16	1/4	¾	23/8	67/16	6
	2	13/8	1¼-12	1-14	15/8	1.999	5/8	11/8	25/8	15/16	3/8	1	25/8	611/16	6¼
2½	1(Std.)	1	7/8-14	¾-16	1⅞	1.499	1/2	7/8	17/8	15/16	1/4	¾	23/8	69/16	61/8
	2	13/4	1½-12	1¼-12	2	2.374	¾	1½	3¼	11/16	1/2	1¼	27/8	71/16	65/8
	3	13/8	1¼-12	1-14	15/8	1.999	5/8	11/8	25/8	15/16	3/8	1	25/8	613/16	63/8
3¼	1(Std.)	13/8	1¼-12	1-14	15/8	1.999	5/8	11/8	2½	15/16	1/4	7/8	23/4	711/16	71/8
	2	2	13/4-12	1½-12	2¼	2.624	7/8	11/8	3½	115/16	3/8	1¼	31/8	81/16	7½
	3	13/4	1½-12	1¼-12	2	2.374	¾	1½	31/8	111/16	3/8	11/8	3	715/16	73/8
4	1(Std.)	13/4	1½-12	1¼-12	2	2.374	¾	1½	3	111/16	1/4	1	3	83/16	75/8
	2	2½	2¼-12	17/8-12	3	3.124	1	21/16	43/8	23/8	3/8	13/8	33/8	89/16	8
	3	2	13/4-12	1½-12	2¼	2.624	7/8	111/16	33/8	115/16	1/4	11/8	31/8	85/16	7¾
5	1(Std.)	2	13/4-12	1½-12	2¼	2.624	7/8	111/16	33/8	115/16	1/4	11/8	31/8	91/16	8¼
	2	3½	3¼-12	2½-12	3½	4.249	1	3	47/8	33/8	3/8	13/8	33/8	95/16	8½
	3	2½	2¼-12	17/8-12	3	3.124	1	21/16	43/8	23/8	3/8	13/8	33/8	95/16	8½
	4	3	23/4-12	2¼-12	3½	3.749	1	25/8	47/8	27/8	3/8	13/8	33/8	95/16	8½
6	1(Std.)	2½	2¼-12	17/8-12	3	3.124	1	21/16	4¼	23/8	1/4	1¼	3½	10½	95/8
	2	4	33/4-12	3-12	4	4.749	1	33/8	5¼	37/8	1/4	1¼	3½	10½	95/8
	3	3	23/4-12	2¼-12	3½	3.749	1	25/8	4¾	27/8	1/4	1¼	3½	10½	95/8
	4	3½	3¼-12	2½-12	3½	4.249	1	3	4¾	33/8	1/4	1¼	3½	10½	95/8

Table 3 —
Envelope and
Mounting
Dimensions

B

For Cylinder Division Plant Locations – See Page II.



Rectangular Flange and Head Mountings
1½" to 6" Bore Sizes

Series 2H
Heavy Duty Hydraulic Cylinders

Head Rectangular Flange Mounting
Style J
(NFPA Style MF1)

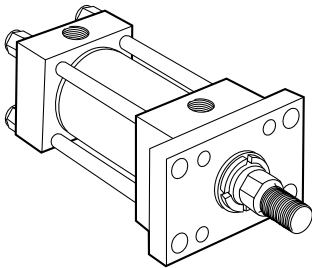

For Style "J" Mount

Bore Size	Max. PSI — Push*				
	Rod Code				
	1	2	3	4	5
1½	2500	1500	—	—	—
2	2500	1500	—	—	—
2½	2500	1500	1900	—	—
3¼	2500	1500	2100	—	—
4	2500	1500	1800	—	—
5	2200	750	1650	1200	—
6	1800	750	1450	1100	—

*Maximum pressure rating — push application.

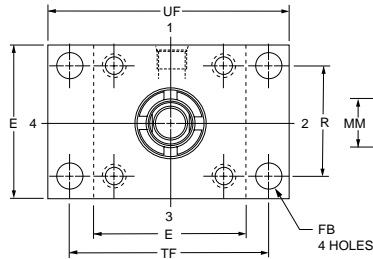

For pressures exceeding those shown use mounting styles JB or JJ.

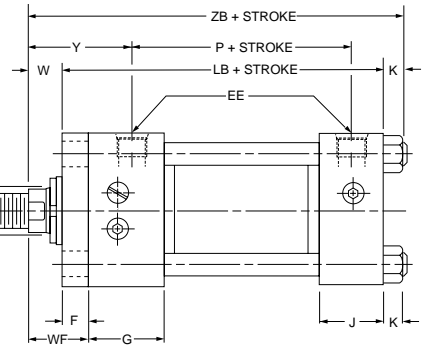

Head Square Flange Mounting
Style JB
(NFPA Style MF5)

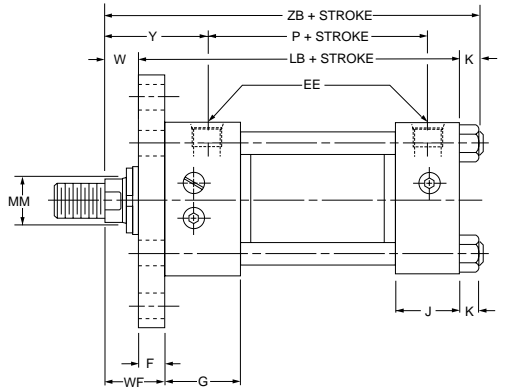
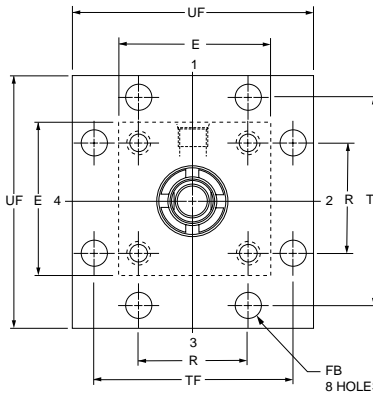
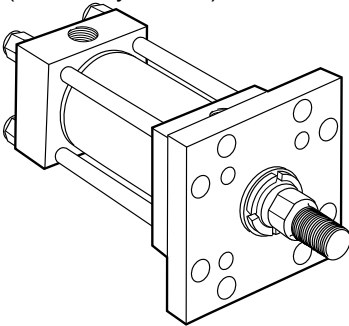

Head Rectangular Mounting
Style JJ
(NFPA Style ME5)

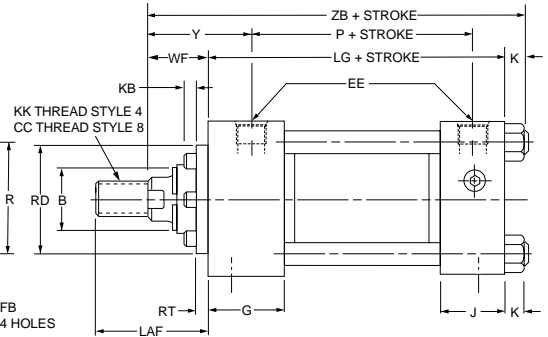
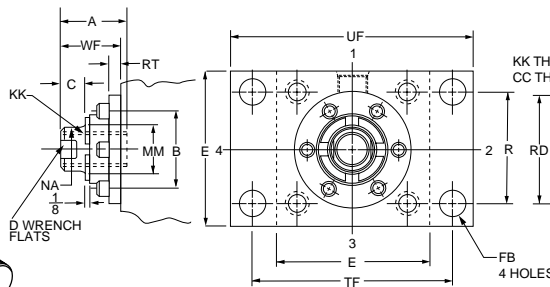
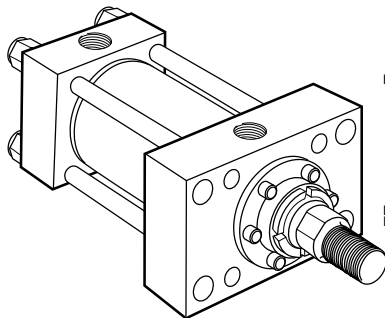

Rod End Dimensions — see table 2

Thread Style 4
(NFPA Style SM)
Small Male

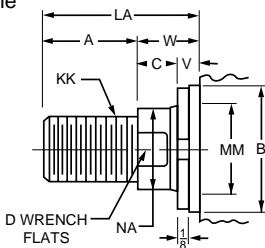

A high strength rod end stud is supplied on thread style 4 through 2" diameter rods and on thread style 8 through 1½" diameter rods. Larger sizes or special rod ends are cut threads. Style 4 rod ends are recommended where the workpiece is secured against the rod shoulder.

Thread Style 8
(NFPA Style IM)
Intermediate Male

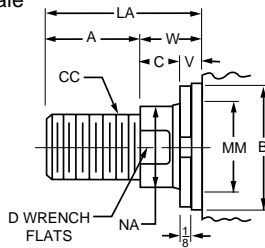

When the workpiece is not shouldered, style 4 rod ends are recommended through 2" piston rod diameters and style 8 rod ends are recommended on larger diameters. Use style 9 for applications where female rod end threads are required. If rod end is not specified, style 4 will be supplied.

Thread Style 9
(NFPA Style SF)
Small Female

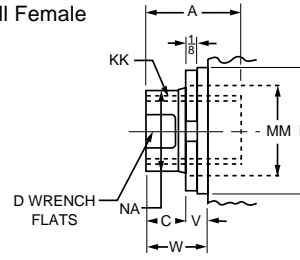

"Special" Thread Style 3

Special thread, extension, rod eye, blank, etc., are also available.

To order, specify "Style 3" and give desired dimensions for CC or KK, A and LA. If otherwise special, furnish dimensioned sketch.

For additional information — call your local Parker Cylinder Distributor.

Series 2H Heavy Duty Hydraulic Cylinders

Rectangular Flange
and Head Mountings
1½" to 6" Bore Sizes

Table 1—Envelope and Mounting Dimensions

Bore	E	EE		F	FB	G	J	K	R	TF	UF	Add Stroke		
		NPTF [⊖]	SAE★									LB	LG	P
1½	2½	½	10	¾	7/16	1¾	1½	¾	1.63	37/16	4¼	5	4⅝	27/8
2	3	½	10	⅝	9/16	1¾	1½	7/16	2.05	4⅞	5⅛	5¼	4⅝	27/8
2½	3½	½	10	⅝	9/16	1¾	1½	7/16	2.55	4⅝	5⅝	5⅜	4¾	3
3¼	4½	¾	12	¾	11/16	2	1¾	9/16	3.25	5⅞	7⅛	6¼	5½	3½
4	5	¾	12	7/8	11/16	2	1¾	9/16	3.82	6⅜	7⅝	6⅝	5¾	3¾
5	6½	¾	12	7/8	15/16	2	1¾	13/16	4.95	8³/16	9¾	7⅞	6¼	4¼
6	7½	1	16	1	11/16	2¼	2¼	7/8	5.73	97/16	11¼	8³/8	7³/8	47/8

★ SAE straight thread ports are standard and are indicated by port number.
[⊖] NPTF ports are available at no extra charge.

Table 2—Rod Dimensions

Bore	Rod No.	Rod Dia. MM	Thread		Rod Extensions and Pilot Dimensions													Add Stroke	
			Style 8 CC	Style 4 & 9 KK	A	+0.000 -0.002 B	C	D	KB	LA	LAF	NA	V	W	RD	RT	WF		Y
1½	1(Std.)	5/8	1/2-20	7/16-20	¾	1.124	¾	1/2	0	13/8	13/4	9/16	1/4	5/8	21/8	3/8	1	2	6
	2	1	7/8-14	¾-16	11/8	1.499	1/2	7/8	0	21/8	21/2	15/16	1/2	1	21/2	3/8	13/8	23/8	63/8
2	1(Std.)	1	7/8-14	¾-16	11/8	1.499	1/2	7/8	0	17/8	21/2	15/16	1/4	¾	21/2	3/8	13/8	23/8	67/16
	2	13/8	11/4-12	1-14	15/8	1.999	5/8	11/8	1/4	25/8	31/4	15/16	3/8	1	3	3/8	15/8	25/8	611/16
2½	1(Std.)	1	7/8-14	¾-16	11/8	1.499	1/2	7/8	0	17/8	21/2	15/16	1/4	¾	21/2	3/8	13/8	23/8	69/16
	2	13/4	11/2-12	11/4-12	2	2.374	¾	11/2	1/4	31/4	37/8	111/16	1/2	11/4	31/2	3/8	17/8	27/8	71/16
	3	13/8	11/4-12	1-14	15/8	1.999	5/8	11/8	1/4	25/8	31/4	15/16	3/8	1	3	3/8	15/8	25/8	613/16
3¼	1(Std.)	13/8	11/4-12	1-14	15/8	1.999	5/8	11/8	1/4	21/2	31/4	15/16	1/4	7/8	3	3/8	15/8	23/4	711/16
	2	2	13/4-12	11/2-12	21/4	2.624	7/8	111/16	1/8	31/2	41/4	115/16	3/8	11/4	4	5/8	2	31/8	81/16
	3	13/4	11/2-12	11/4-12	2	2.374	¾	11/2	1/4	31/8	37/8	111/16	3/8	11/8	31/2	3/8	17/8	3	715/16
4	1(Std.)	13/4	11/2-12	11/4-12	2	2.374	¾	11/2	1/4	3	37/8	111/16	1/4	1	31/2	3/8	17/8	3	83/16
	2	21/2	21/4-12	17/8-12	3	3.124	1	21/16	1/4	43/8	51/4	23/8	3/8	13/8	41/2	5/8	21/4	33/8	89/16
	3	2	13/4-12	11/2-12	21/4	2.624	7/8	111/16	1/8	33/8	41/4	115/16	1/4	11/8	4	5/8	2	31/8	85/16
5	1(Std.)	2	13/4-12	11/2-12	21/4	2.624	7/8	111/16	1/8	33/8	41/4	115/16	1/4	11/8	4	5/8	2	31/8	91/16
	2	31/2	31/4-12	21/2-12	31/2	4.249	1	3	1/4	47/8	53/4	33/8	3/8	13/8	53/4	5/8	21/4	33/8	95/16
	3	21/2	21/4-12	17/8-12	3	3.124	1	21/16	1/4	43/8	51/4	23/8	3/8	13/8	41/2	5/8	21/4	33/8	95/16
	4	3	23/4-12	21/4-12	31/2	3.749	1	25/8	1/4	47/8	53/4	27/8	3/8	13/8	51/4	5/8	21/4	33/8	95/16
6	1(Std.)	21/2	21/4-12	17/8-12	3	3.124	1	21/16	1/4	41/4	51/4	23/8	1/4	11/4	41/2	5/8	21/4	31/2	101/2
	2	4	33/4-12	3-12	4	4.749	1	33/8	1/4	51/4	61/4	37/8	1/4	11/4	61/2	¾	21/4	31/2	101/2
	3	3	23/4-12	21/4-12	31/2	3.749	1	25/8	1/4	43/4	53/4	27/8	1/4	11/4	51/4	5/8	21/4	31/2	101/2
	4	31/2	31/4-12	21/2-12	31/2	4.249	1	3	1/4	43/4	53/4	33/8	1/4	11/4	53/4	5/8	21/4	31/2	101/2

**Table 3 —
Envelope and
Mounting
Dimensions**

B

For Cylinder Division Plant Locations – See Page II.



Rectangular Flange and Cap Mountings
1½" to 6" Bore Sizes

Series 2H
Heavy Duty Hydraulic Cylinders

Cap Rectangular Flange Mounting
Style H
(NFFPA Style MF2)

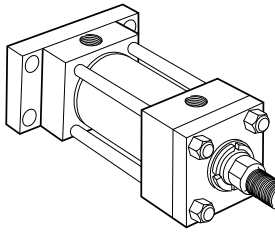

Bore Size	Max. PSI — Pull*				
	Rod Code				
	1	2	3	4	5
1½	3000	3000	—	—	—
2	3000	3000	—	—	—
2½	3000	3000	3000	—	—
3¼	3000	3000	3000	—	—
4	3000	3000	3000	—	—
5	2000	3000	2500	2800	—
6	2000	3000	2500	2800	—

*Maximum pressure rating — pull application.

For pressures exceeding those shown use mounting styles HB or HH.

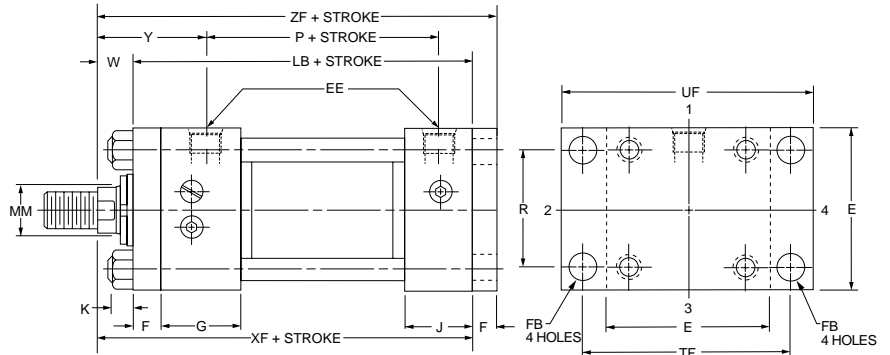

Cap Square Flange Mounting
Style HB
(NFFPA Style MF6)

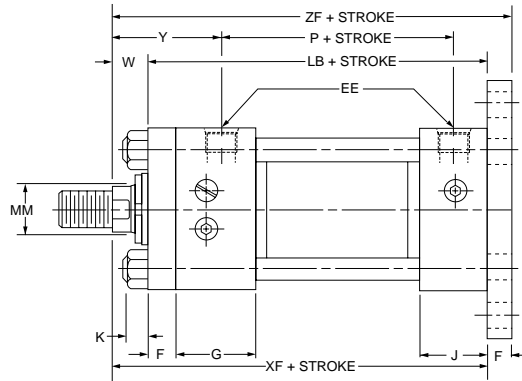
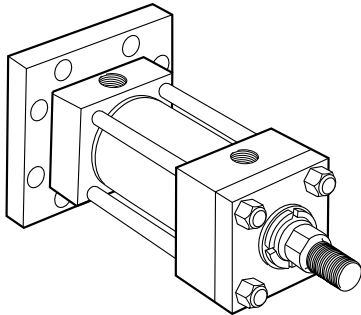

Cap Rectangular Mounting
Style HH
(NFFPA Style ME6)

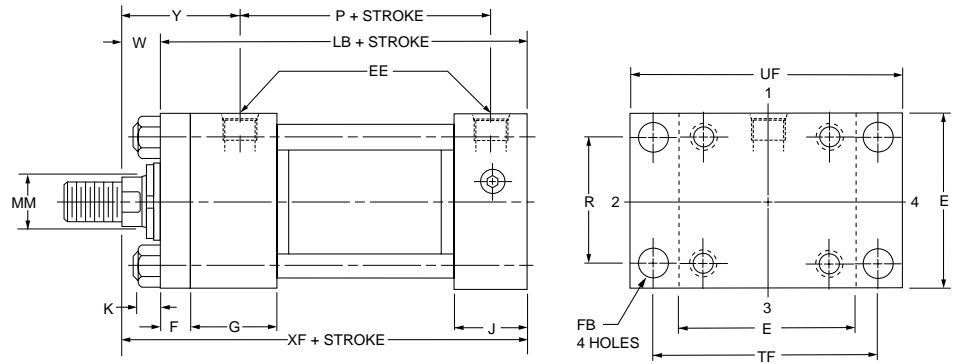
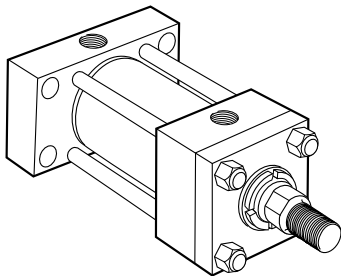

Rod End Dimensions — see table 2

Thread Style 4
(NFFPA Style SM)
Small Male

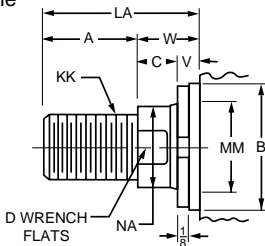

A high strength rod end stud is supplied on thread style 4 through 2" diameter rods and on thread style 8 through 1½" diameter rods. Larger sizes or special rod ends are cut threads. Style 4 rod ends are recommended where the workpiece is secured against the rod shoulder.

Thread Style 8
(NFFPA Style IM)
Intermediate Male

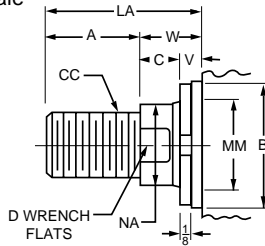

When the workpiece is not shouldered, style 4 rod ends are recommended through 2" piston rod diameters and style 8 rod ends are recommended on larger diameters. Use style 9 for applications where female rod end threads are required. If rod end is not specified, style 4 will be supplied.

Thread Style 9
(NFFPA Style SF)
Small Female

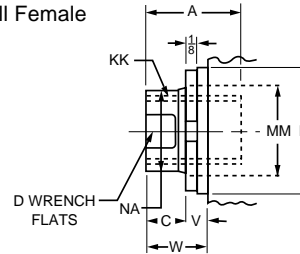

"Special" Thread Style 3

Special thread, extension, rod eye, blank, etc., are also available.

To order, specify "Style 3" and give desired dimensions for CC or KK, A and LA. If otherwise special, furnish dimensioned sketch.

For additional information — call your local Parker Cylinder Distributor.

Series 2H Heavy Duty Hydraulic Cylinders

Rectangular Flange
and Cap Mountings
1½" to 6" Bore Sizes

Table 1—Envelope and Mounting Dimensions

Bore	E	EE		F	FB	G	J	K	R	TF	UF	Add Stroke	
		NPTF \ominus	SAE \star									LB	P
1½	2½	½	10	¾	7/16	1¾	1½	¾	1.63	37/16	4¼	5	27/8
2	3	½	10	5/8	9/16	1¾	1½	7/16	2.05	4½	5½	5¼	27/8
2½	3½	½	10	5/8	9/16	1¾	1½	7/16	2.55	45/8	55/8	53/8	3
3¼	4½	¾	12	¾	11/16	2	1¾	9/16	3.25	57/8	7½	6¼	3½
4	5	¾	12	7/8	11/16	2	1¾	9/16	3.82	63/8	75/8	65/8	3¾
5	6½	¾	12	7/8	15/16	2	1¾	13/16	4.95	83/16	9¾	7½	4¼
6	7½	1	16	1	11/16	2¼	2¼	7/8	5.73	97/16	11¼	83/8	47/8

★ SAE straight thread ports are standard and are indicated by port number.

⊖ NPTF ports are available at no extra charge.

**Table 3 —
Envelope and
Mounting
Dimensions**

Table 2—Rod Dimensions

Bore	Rod No.	Rod Dia. MM	Thread		Rod Extensions and Pilot Dimensions								Add Stroke			
			Style 8 CC	Style 4 & 9 KK	A	+0.000 -0.002 B	C	D	LA	NA	V	W	WF	Y	XF	ZF
1½	1(Std.)	5/8	1/2-20	7/16-20	¾	1.124	¾	½	13/8	9/16	¼	5/8	1	2	55/8	6
	2	1	7/8-14	¾-16	1½	1.499	½	7/8	2½	15/16	½	1	13/8	23/8	6	63/8
2	1(Std.)	1	7/8-14	¾-16	1½	1.499	½	7/8	17/8	15/16	¼	¾	13/8	23/8	6	65/8
	2	13/8	1¼-12	1-14	15/8	1.999	5/8	11/8	25/8	15/16	¾	1	15/8	25/8	6¼	67/8
2½	1(Std.)	1	7/8-14	¾-16	1½	1.499	½	7/8	17/8	15/16	¼	¾	13/8	23/8	6½	6¾
	2	13/4	1½-12	1¼-12	2	2.374	¾	1½	3¼	111/16	½	1¼	17/8	27/8	65/8	7¼
3¼	1(Std.)	13/8	1¼-12	1-14	15/8	1.999	5/8	11/8	25/8	15/16	¾	1	15/8	25/8	63/8	7
	2	2	13/4-12	1½-12	2¼	2.624	7/8	111/16	3½	115/16	¾	1¼	2	31/8	7½	8¼
4	1(Std.)	13/4	1½-12	1¼-12	2	2.374	¾	1½	3	111/16	¾	1	17/8	3	75/8	8½
	2	2½	2¼-12	17/8-12	3	3.124	1	21/16	43/8	23/8	¾	13/8	2¼	33/8	8	87/8
5	1(Std.)	2	13/4-12	1½-12	2¼	2.624	7/8	111/16	33/8	115/16	¼	11/8	2	31/8	7¾	85/8
	2	3½	3¼-12	2½-12	3½	4.249	1	3	47/8	33/8	¾	13/8	2¼	33/8	8¼	9½
6	1(Std.)	2½	2¼-12	17/8-12	3	3.124	1	21/16	43/8	23/8	¾	13/8	2¼	33/8	8½	93/8
	2	4	3¾-12	3-12	4	4.749	1	33/8	5¼	37/8	¼	1¼	2¼	3½	95/8	105/8
6	3	3	2¾-12	2¼-12	3½	3.749	1	25/8	43/4	27/8	¼	1¼	2¼	3½	95/8	105/8
	4	3½	3¼-12	2½-12	3½	4.249	1	3	43/4	33/8	¼	1¼	2¼	3½	95/8	105/8

B

For Cylinder Division Plant Locations – See Page II.



**Side Lugs, Centerline Lugs
and Side Tapped Mountings**
1½" to 6" Bore Sizes

Series 2H
Heavy Duty Hydraulic Cylinders

Side Lug Mountings
Style C
(NFPA Style MS2)

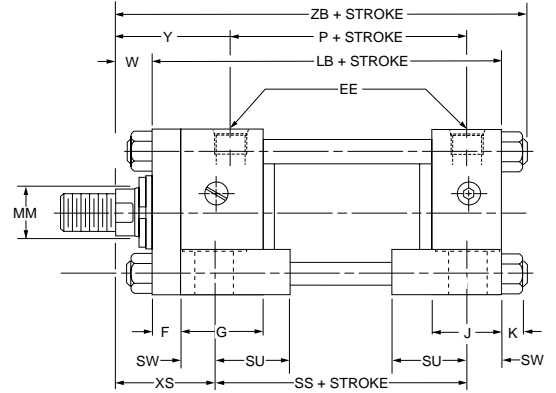
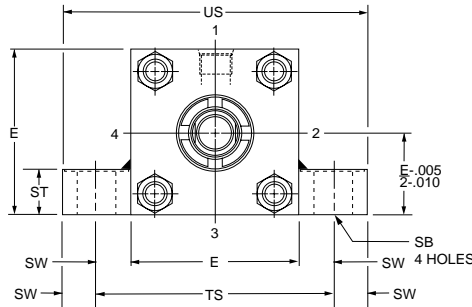
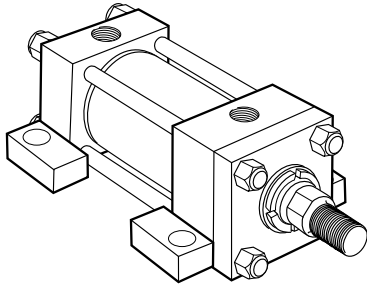

Centerline Lugs Mounting
Style E
(NFPA Style MS3)

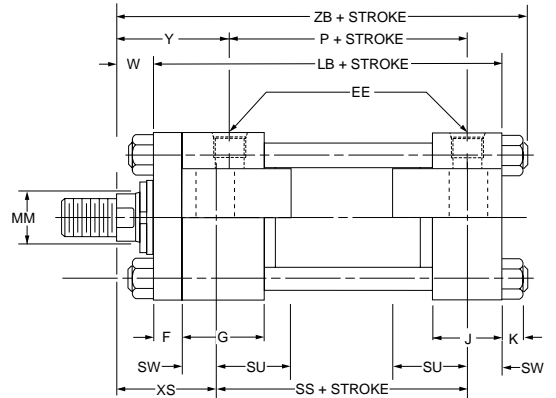
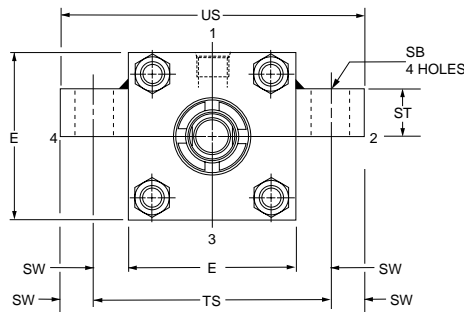
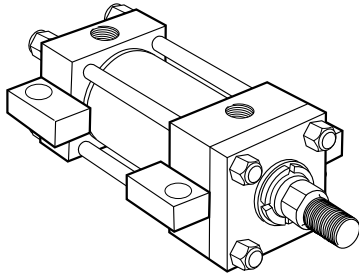

Side Tapped Mounting
Style F
(NFPA Style MS4)

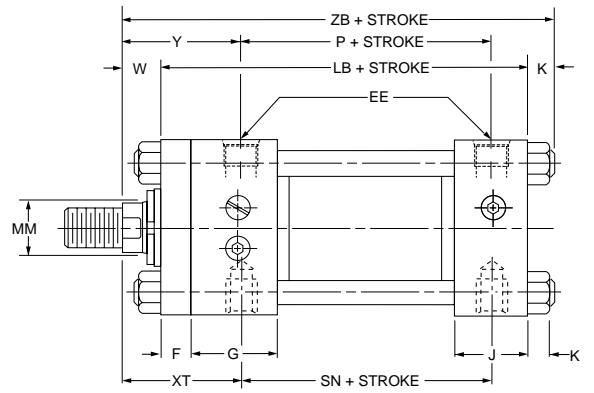
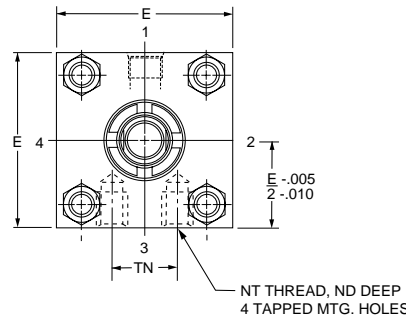
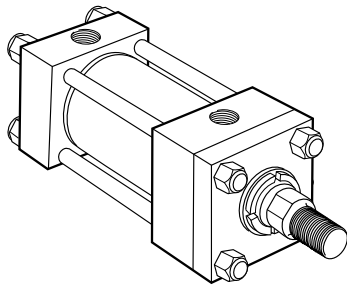

Rod End Dimensions — see table 2

Thread Style 4
(NFPA Style SM)
Small Male

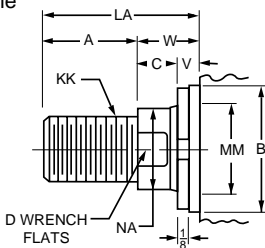

A high strength rod end stud is supplied on thread style 4 through 2" diameter rods and on thread style 8 through 1½" diameter rods. Larger sizes or special rod ends are cut threads. Style 4 rod ends are recommended where the workpiece is secured against the rod shoulder.

Thread Style 8
(NFPA Style IM)
Intermediate Male

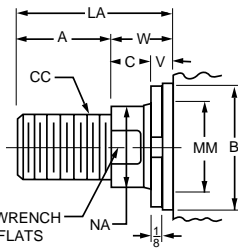

When the workpiece is not shouldered, style 4 rod ends are recommended through 2" piston rod diameters and style 8 rod ends are recommended on larger diameters. Use style 9 for applications where female rod end threads are required. If rod end is not specified, style 4 will be supplied.

Thread Style 9
(NFPA Style SF)
Small Female

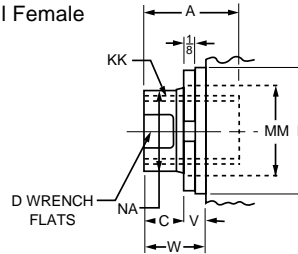

"Special" Thread Style 3

Special thread, extension, rod eye, blank, etc., are also available.

To order, specify "Style 3" and give desired dimensions for CC or KK, A and LA. If otherwise special, furnish dimensioned sketch.

For additional information – call your local Parker Cylinder Distributor.

Series 2H Heavy Duty Hydraulic Cylinders

Side Lugs, Centerline Lugs
and Side Tapped Mountings
1½" to 6" Bore Sizes

Table 1—Envelope and Mounting Dimensions

Bore	E	EE		F	G	J	K	NT	SB*	ST	SU	SW	TN	TS	US	Add Stroke			
		NPTF \ominus	SAE \star													LB	P	SN	SS
1½	2½	½	10	¾	1¾	1½	¾	¾-16	7/16	½	15/16	¾	¾	¾	4	5	27/8	27/8	37/8
2	3	½	10	5/8	1¾	1½	7/16	1½-13	9/16	¾	1¼	½	15/16	4	5	5¼	27/8	27/8	35/8
2½	3½	½	10	5/8	1¾	1½	7/16	5/8-11	13/16	1	19/16	11/16	15/16	47/8	6¼	53/8	3	3	33/8
3¼	4½	¾	12	¾	2	1¾	9/16	¾-10	13/16	1	19/16	11/16	1½	57/8	7¼	6¼	3½	3½	41/8
4	5	¾	12	7/8	2	1¾	9/16	1-8	11/16	1¼	2	7/8	21/16	6¾	8½	65/8	3¾	3¾	4
5	6½	¾	12	7/8	2	1¾	13/16	1-8	11/16	1¼	2	7/8	215/16	8¼	10	71/8	4¼	4¼	4½
6	7½	1	16	1	2¼	2¼	7/8	1¼-7	15/16	1½	2½	1½	35/16	9¾	12	83/8	47/8	51/8	51/8

★ SAE straight thread ports are standard and are indicated by port number.

⊖ NPTF ports are available at no extra charge.

* Upper surface spotfaced for socket head screws.

**Table 3 —
Envelope and
Mounting
Dimensions**

Table 2—Rod Dimensions

Bore	Rod No.	Rod Dia. MM	Thread		Rod Extensions and Pilot Dimensions								ND	XS	XT	Y	Add Stroke ZB
			Style 8 CC	Style 4 & 9 KK	A	+0.000 -0.002 B	C	D	LA	NA	V	W					
1½	1(Std.)	5/8	1/2-20	7/16-20	¾	1.124	¾	½	13/8	9/16	¼	5/8	¾	13/8	2	2	6
	2	1	7/8-14	¾-16	11/8	1.499	½	7/8	21/8	15/16	½	1	¾	1¾	23/8	23/8	63/8
2	1(Std.)	1	7/8-14	¾-16	11/8	1.499	½	7/8	17/8	15/16	¼	¾	7/16	17/8	23/8	23/8	67/16
	2	13/8	1¼-12	1-14	15/8	1.999	5/8	11/8	25/8	15/16	¾	1	7/16	21/8	25/8	25/8	611/16
2½	1(Std.)	1	7/8-14	¾-16	11/8	1.499	½	7/8	17/8	15/16	¼	¾	½	21/16	23/8	23/8	69/16
	2	13/4	1½-12	1¼-12	2	2.374	¾	1½	31/4	111/16	½	1¼	½	29/16	27/8	27/8	71/16
	3	13/8	1¼-12	1-14	15/8	1.999	5/8	11/8	25/8	15/16	¾	1	½	25/16	25/8	25/8	613/16
3¼	1(Std.)	13/8	1¼-12	1-14	15/8	1.999	5/8	11/8	21/2	15/16	¼	7/8	11/16	25/16	23/4	23/4	711/16
	2	2	1¾-12	1½-12	2¼	2.624	7/8	111/16	31/2	115/16	¾	1¼	11/16	211/16	31/8	31/8	81/16
	3	13/4	1½-12	1¼-12	2	2.374	¾	1½	31/8	111/16	¾	11/8	11/16	29/16	3	3	715/16
4	1(Std.)	13/4	1½-12	1¼-12	2	2.374	¾	1½	3	111/16	¼	1	11/16	2¾	3	3	83/16
	2	2½	2¼-12	17/8-12	3	3.124	1	21/16	43/8	23/8	¾	13/8	11/16	31/8	33/8	33/8	89/16
	3	2	1¾-12	1½-12	2¼	2.624	7/8	111/16	33/8	115/16	¼	11/8	11/16	27/8	31/8	31/8	85/16
5	1(Std.)	2	1¾-12	1½-12	2¼	2.624	7/8	111/16	33/8	115/16	¼	11/8	1	27/8	31/8	31/8	91/16
	2	3½	3¼-12	2½-12	3½	4.249	1	3	47/8	33/8	¾	13/8	1	31/8	33/8	33/8	95/16
	3	2½	2¼-12	17/8-12	3	3.124	1	21/16	43/8	23/8	¾	13/8	1	31/8	33/8	33/8	95/16
	4	3	2¾-12	2¼-12	3½	3.749	1	25/8	47/8	27/8	¾	13/8	1	31/8	33/8	33/8	95/16
6	1(Std.)	2½	2¼-12	17/8-12	3	3.124	1	21/16	41/4	23/8	¼	1¼	11/4	33/8	31/2	31/2	101/2
	2	4	3¾-12	3-12	4	4.749	1	33/8	51/4	37/8	¼	1¼	11/4	33/8	31/2	31/2	101/2
	3	3	2¾-12	2¼-12	3½	3.749	1	25/8	43/4	27/8	¼	1¼	11/4	33/8	31/2	31/2	101/2
	4	3½	3¼-12	2½-12	3½	4.249	1	3	43/4	33/8	¼	1¼	11/4	33/8	31/2	31/2	101/2

B

For Cylinder Division Plant Locations – See Page II.



Side End Angles, Side End Lugs and Cap Fixed Clevis Mountings
1½" to 6" Bore Sizes

Series 2H
Heavy Duty Hydraulic Cylinders

Side End Angles Mounting
Style CB
(NFFPA Style MS1)

The maximum recommended operating pressure for Style CB is 500 psi. The recommended minimum stroke length is two times the bore size.

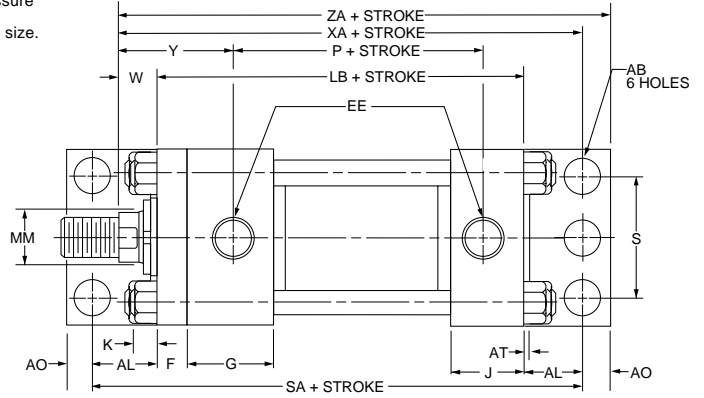
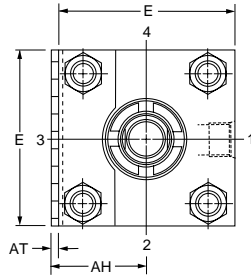
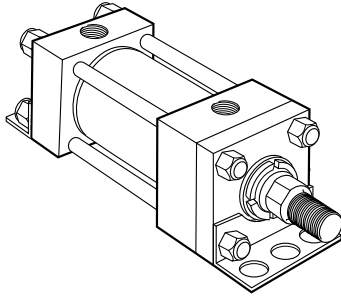

Side End Lugs Mounting
Style G
(NFFPA Style MS7)

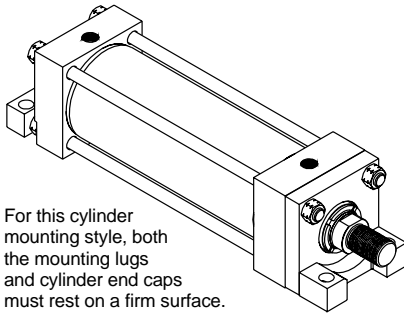

For this cylinder mounting style, both the mounting lugs and cylinder end caps must rest on a firm surface.

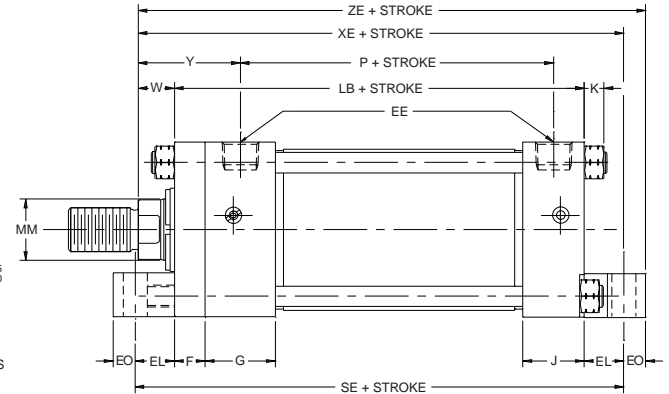
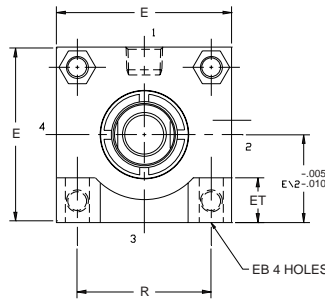

Cap Fixed Clevis Mounting
Style BB
(NFFPA Style MP1)

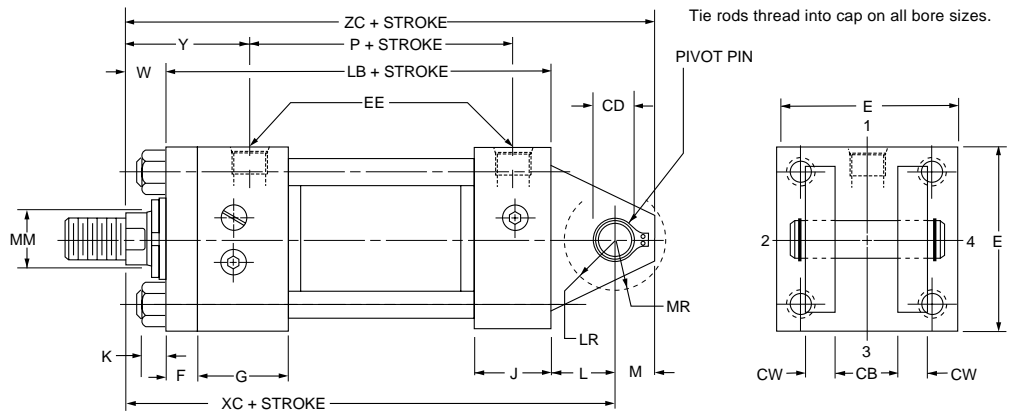
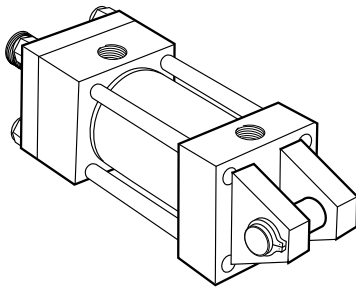

Rod End Dimensions — see table 2

Thread Style 4
(NFFPA Style SM)
Small Male

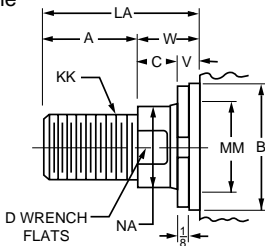

A high strength rod end stud is supplied on thread style 4 through 2" diameter rods and on thread style 8 through 1½" diameter rods. Larger sizes or special rod ends are cut threads. Style 4 rod ends are recommended where the workpiece is secured against the rod shoulder.

Thread Style 8
(NFFPA Style IM)
Intermediate Male

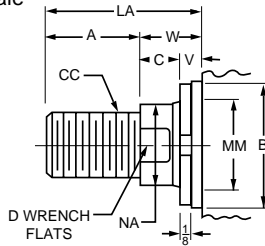

When the workpiece is not shouldered, style 4 rod ends are recommended through 2" piston rod diameters and style 8 rod ends are recommended on larger diameters. Use style 9 for applications where female rod end threads are required. If rod end is not specified, style 4 will be supplied.

Thread Style 9
(NFFPA Style SF)
Small Female

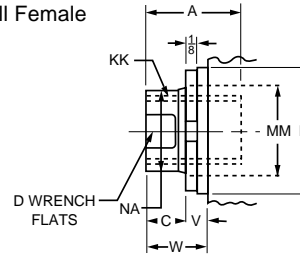

"Special" Thread Style 3

Special thread, extension, rod eye, blank, etc., are also available.

To order, specify "Style 3" and give desired dimensions for CC or KK, A and LA. If otherwise special, furnish dimensioned sketch.

For additional information – call your local Parker Cylinder Distributor.

Series 2H Heavy Duty Hydraulic Cylinders

Side End Angles, Side End Lugs
and Cap Fixed Clevis Mountings
1½" to 6" Bore Sizes

Table 1—Envelope and Mounting Dimensions

Bore	AB	AH	AL	AO	AT	CB	+.000 -.002 CD*	CW	E	EB	EE		EL	EO	ES	ET	F	G	J	K	L	LR	M	MR	R	S	Add Stroke			
											NPTF	SAE															LB	P	SA	SE
1½	7/16	13/8	1	3/8	1/8	3/4	.501	1/2	2½	7/16	1/2	10	7/8	3/8	7/8	3/4	3/8	1¾	1½	3/8	3/4	9/16	1/2	5/8	1.63	1¾	5	27/8	7	6¾
2	9/16	11½/16	1¼	1/2	1/8	1¼	.751	5/8	3	9/16	1/2	10	15/16	1/2	15/16	7/8	5/8	1¾	1½	7/16	1¼	1	¾	15/16	2.05	2	5¼	27/8	7¾	7½
2½	11/16	115/16	13/16	9/16	1/8	1¼	.751	5/8	3½	9/16	1/2	10	15/16	1/2	15/16	7/8	5/8	1¾	1½	7/16	1¼	15/16	¾	15/16	2.55	2¾	5¾	3	7¾	7¼
3¼	13/16	29/16	113/16	11/16	1/4	1½	1.001	¾	4½	11/16	¾	12	11/8	5/8	1¼	1¼	¾	2	1¾	9/16	1½	1¼	1	13/16	3.25	31/8	6¼	3½	97/8	8½
4	1½/16	213/16	21/8	7/8	1/4	2	1.376	1	5	11/16	¾	12	11/8	5/8	1¼	1¼	7/8	2	1¾	9/16	21/8	1¾	13/8	15/8	3.82	3¼	65/8	3¾	107/8	87/8
5	1½/16	311/16	21/8	7/8	5/16	2½	1.751	1¼	6½	15/16	¾	12	11/2	¾	1½	1½	7/8	2	1¾	13/16	2¼	21/16	1¾	21/8	4.95	4¾	71/8	4¼	11¾	10½
6	15/16	4¼	27/16	11/16	¾	2½	2.001	1¼	7½	11/16	1	16	11/16	7/8	1¾	1¾	1	2¼	2¼	7/8	2½	25/16	2	23/8	5.73	5¾	8¾	47/8	13¼	11¾

* SAE straight thread ports are standard and are indicated by port number.
 ⊖ NPTF ports are available at no extra charge.
 * Dimension CD is pin diameter.

**Table 3 —
Envelope and
Mounting
Dimensions**

Table 2—Rod Dimensions

Bore	Rod No.	Rod Dia. MM	Thread		Rod Extensions and Pilot Dimensions								Add Stroke						
			Style 8 CC	Style 4 & 9 KK	A	+.000 -.002 B	C	D	LA	NA	V	W	Y	XA	XC	XE	ZA	ZC	ZE
1½	1(Std.)	5/8	1½-20	7/16-20	¾	1.124	¾	1/2	13/8	9/16	1/4	5/8	2	65/8	63/8	61/2	7	67/8	67/8
	2	1	7/8-14	¾-16	11/8	1.499	1/2	7/8	21/8	15/16	1/2	1	23/8	7	6¾	67/8	73/8	7¼	7¼
2	1(Std.)	1	7/8-14	¾-16	11/8	1.499	1/2	7/8	17/8	15/16	1/4	¾	23/8	7¼	7¼	615/16	7¾	8	77/16
	2	13/8	11/4-12	1-14	15/8	1.999	5/8	11/8	25/8	15/16	¾	1	25/8	7½	7½	73/16	8	8¼	711/16
2½	1(Std.)	1	7/8-14	¾-16	11/8	1.499	1/2	7/8	17/8	15/16	1/4	¾	23/8	75/16	73/8	71/16	77/8	81/8	79/16
	2	1¾	11/2-12	11/4-12	2	2.374	¾	11/2	31/4	111/16	1/2	1¼	27/8	713/16	77/8	79/16	83/8	85/8	81/16
	3	13/8	11/4-12	1-14	15/8	1.999	5/8	11/8	25/8	15/16	¾	1	25/8	79/16	75/8	75/16	81/8	83/8	713/16
3¼	1(Std.)	13/8	11/4-12	1-14	15/8	1.999	5/8	11/8	21/2	15/16	1/4	7/8	23/4	815/16	85/8	81/4	95/8	95/8	87/8
	2	2	13/4-12	11/2-12	2¼	2.624	7/8	111/16	31/2	115/16	¾	1¼	31/8	95/16	9	85/8	10	10	9¼
	3	1¾	11/2-12	11/4-12	2	2.374	¾	11/2	31/8	111/16	¾	11/8	3	93/16	87/8	81/2	97/8	97/8	91/8
4	1(Std.)	1¾	11/2-12	11/4-12	2	2.374	¾	11/2	3	111/16	1/4	1	3	93/4	93/4	83/4	105/8	111/8	93/8
	2	2½	21/4-12	17/8-12	3	3.124	1	21/16	43/8	23/8	¾	13/8	33/8	101/8	101/8	91/8	11	111/2	93/4
	3	2	13/4-12	11/2-12	2¼	2.624	7/8	111/16	33/8	115/16	1/4	11/8	31/8	97/8	97/8	87/8	10¾	111/4	91/2
5	1(Std.)	2	13/4-12	11/2-12	2¼	2.624	7/8	111/16	33/8	115/16	1/4	11/8	31/8	103/8	101/2	9¾	111/4	121/4	101/2
	2	3½	31/4-12	21/2-12	3½	4.249	1	3	47/8	33/8	¾	13/8	33/8	105/8	10¾	10	111/2	121/2	103/4
	3	2½	21/4-12	17/8-12	3	3.124	1	21/16	43/8	23/8	¾	13/8	33/8	105/8	10¾	10	111/2	121/2	103/4
	4	3	23/4-12	21/4-12	3½	3.749	1	25/8	47/8	27/8	¾	13/8	33/8	105/8	10¾	10	111/2	121/2	103/4
6	1(Std.)	2½	21/4-12	17/8-12	3	3.124	1	21/16	41/4	23/8	1/4	1¼	31/2	121/16	121/8	115/16	131/8	141/8	123/16
	2	4	3¾-12	3-12	4	4.749	1	33/8	51/4	37/8	1/4	1¼	31/2	121/16	121/8	115/16	131/8	141/8	123/16
	3	3	23/4-12	21/4-12	3½	3.749	1	25/8	43/4	27/8	1/4	1¼	31/2	121/16	121/8	115/16	131/8	141/8	123/16
	4	3½	31/4-12	21/2-12	3½	4.249	1	3	43/4	33/8	1/4	1¼	31/2	121/16	121/8	115/16	131/8	141/8	123/16

Caution: When using mounting styles CB and G, check clearance between mounting members and rod attachment or accessory. If necessary, specify longer rod extension to avoid interference with mounting members.

For Cylinder Division Plant Locations – See Page II.



Trunnion Mountings
1½" to 6" Bore Sizes

Series 2H Heavy Duty Hydraulic Cylinders

Head Trunnion Mounting
Style D
(NFFA Style MT1)

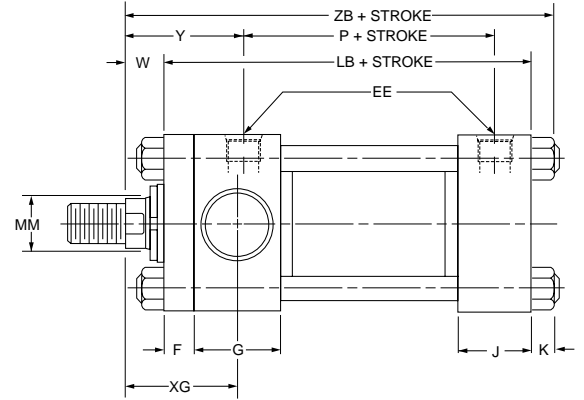
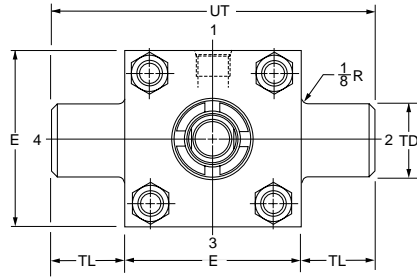
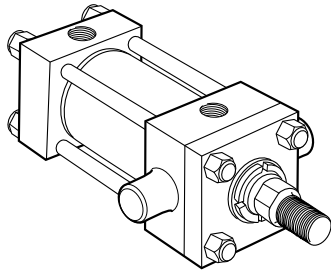

Cap Trunnion Mounting
Style DB
(NFFA Style MT2)

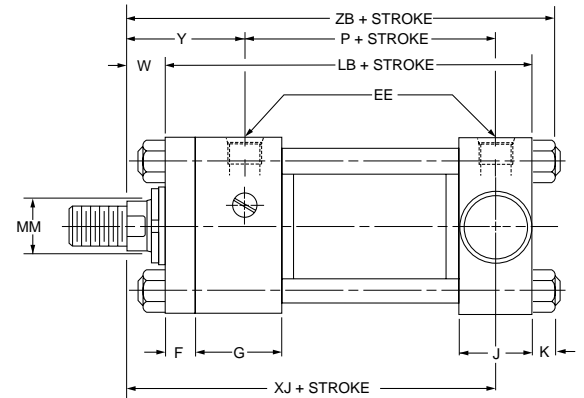
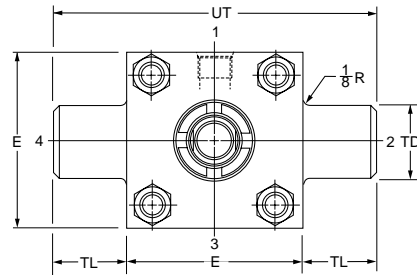
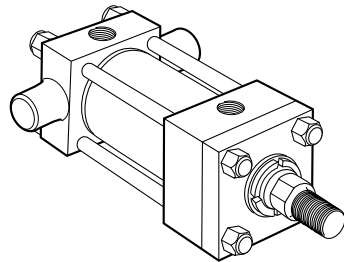

Intermediate Fixed Trunnion Mounting
Style DD
(NFFA Style MT4)

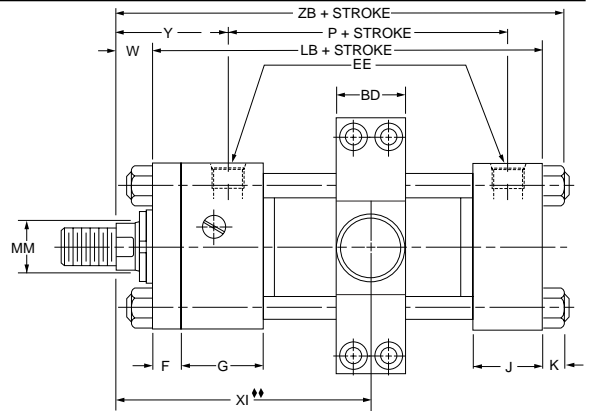
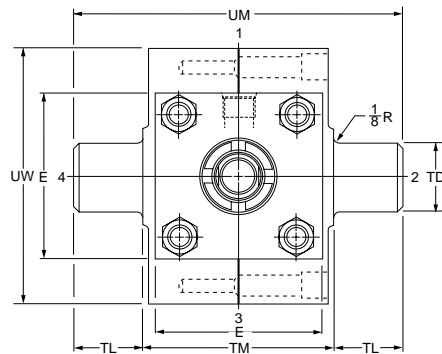
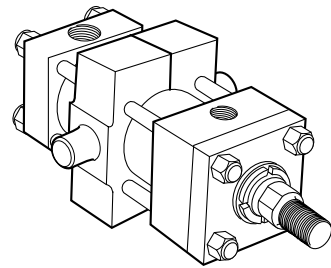

Rod End Dimensions — see table 2

Thread Style 4
(NFFA Style SM)
Small Male

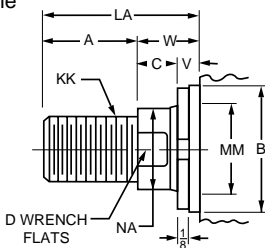

Thread Style 8
(NFFA Style IM)
Intermediate Male

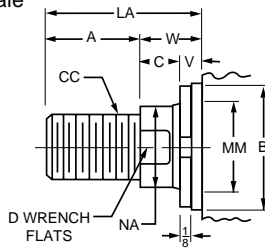

Thread Style 9
(NFFA Style SF)
Small Female

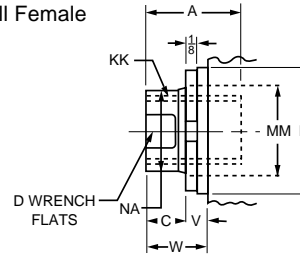

“Special” Thread Style 3

Special thread, extension, rod eye, blank, etc., are also available.

To order, specify “Style 3” and give desired dimensions for CC or KK, A and LA. If otherwise special, furnish dimensioned sketch.

A high strength rod end stud is supplied on thread style 4 through 2" diameter rods and on thread style 8 through 1½" diameter rods. Larger sizes or special rod ends are cut threads. Style 4 rod ends are recommended where the workpiece is secured against the rod shoulder.

When the workpiece is not shouldered, style 4 rod ends are recommended through 2" piston rod diameters and style 8 rod ends are recommended on larger diameters. Use style 9 for applications where female rod end threads are required. If rod end is not specified, style 4 will be supplied.

For additional information – call your local Parker Cylinder Distributor.

Series 2H Heavy Duty Hydraulic Cylinders

Trunnion Mountings
1½" to 6" Bore Sizes

Table 1—Envelope and Mounting Dimensions

Bore	BD	E	EE		F	G	J	K	+0.000 -0.001 TD	TL	TM	UM	UT	UW	Add Stroke		Style DD Minimum Stroke
			NPTF [⊖]	SAE★											LB	P	
1½	1¼	2½	½	10	¾	1¾	1½	¾	1.000	1	3	5	4½	3¾	5	27/8	0
2	1½	3	½	10	5/8	1¾	1½	7/16	1.375	13/8	3½	6¼	5¾	4½	5¼	27/8	¼
2½	1½	3½	½	10	5/8	1¾	1½	7/16	1.375	13/8	4	6¾	6¼	45/8	53/8	3	1/8
3¼	2	4½	¾	12	¾	2	1¾	9/16	1.750	13/4	5	8½	8	513/16	6¼	3½	¾
4	2	5	¾	12	7/8	2	1¾	9/16	1.750	13/4	5½	9	8½	63/8	65/8	3¾	1/8
5	2	6½	¾	12	7/8	2	1¾	13/16	1.750	13/4	7	10½	10	7¾	71/8	4¼	0
6	3	7½	1	16	1	2¼	2¼	7/8	2.000	2	8½	12½	11½	103/8	83/8	47/8	¼

★ SAE straight thread ports are standard and are indicated by port number.
⊖ NPTF ports are available at no extra charge.

**Table 3 —
Envelope and
Mounting
Dimensions**

Table 2—Rod Dimensions

Bore	Rod No.	Rod Dia. MM	Thread		Rod Extensions and Pilot Dimensions								XG	Min. XI	Y	Add Stroke	
			Style 8 CC	Style 4 & 9 KK	A	+0.000 -0.002 B	C	D	LA	NA	V	W				XJ	ZB
1½	1(Std.)	5/8	1/2-20	7/16-20	¾	1.124	¾	1/2	13/8	9/16	1/4	5/8	17/8	37/16	2	47/8	6
	2	1	7/8-14	¾-16	11/8	1.499	1/2	7/8	21/8	15/16	1/2	1	2¼	313/16	23/8	51/4	63/8
2	1(Std.)	1	7/8-14	¾-16	11/8	1.499	1/2	7/8	17/8	15/16	1/4	¾	2¼	315/16	23/8	51/4	67/16
	2	13/8	11/4-12	1-14	15/8	1.999	5/8	11/8	25/8	15/16	¾	1	2½	43/16	25/8	51/2	611/16
2½	1(Std.)	1	7/8-14	¾-16	11/8	1.499	1/2	7/8	17/8	15/16	1/4	¾	2¼	315/16	23/8	53/8	69/16
	2	13/4	11/2-12	11/4-12	2	2.374	¾	11/2	31/4	111/16	1/2	1¼	2¾	47/16	27/8	57/8	71/16
	3	13/8	11/4-12	1-14	15/8	1.999	5/8	11/8	25/8	15/16	¾	1	2½	43/16	25/8	55/8	613/16
3¼	1(Std.)	13/8	11/4-12	1-14	15/8	1.999	5/8	11/8	21/2	15/16	1/4	7/8	25/8	411/16	23/4	61/4	711/16
	2	2	13/4-12	11/2-12	2¼	2.624	7/8	111/16	31/2	115/16	¾	1¼	3	51/16	31/8	65/8	81/16
	3	13/4	11/2-12	11/4-12	2	2.374	¾	11/2	31/8	111/16	¾	11/8	27/8	415/16	3	61/2	715/16
4	1(Std.)	13/4	11/2-12	11/4-12	2	2.374	¾	11/2	3	111/16	1/4	1	27/8	415/16	3	63/4	83/16
	2	2½	2¼-12	17/8-12	3	3.124	1	21/16	43/8	23/8	¾	13/8	3¼	55/16	33/8	71/8	89/16
	3	2	13/4-12	11/2-12	2¼	2.624	7/8	111/16	33/8	115/16	1/4	11/8	3	51/16	31/8	67/8	85/16
5	1(Std.)	2	13/4-12	11/2-12	2¼	2.624	7/8	111/16	33/8	115/16	1/4	11/8	3	51/16	31/8	73/8	91/16
	2	3½	3¼-12	2½-12	3½	4.249	1	3	47/8	33/8	¾	13/8	3¼	55/16	33/8	75/8	95/16
	3	2½	2¼-12	17/8-12	3	3.124	1	21/16	43/8	23/8	¾	13/8	3¼	55/16	33/8	75/8	95/16
6	4	3	2¾-12	2¼-12	3½	3.749	1	25/8	47/8	27/8	¾	13/8	3¼	55/16	33/8	75/8	95/16
	1(Std.)	2½	2¼-12	17/8-12	3	3.124	1	21/16	41/4	23/8	1/4	1¼	33/8	61/16	31/2	83/8	101/2
	2	4	3¾-12	3-12	4	4.749	1	33/8	51/4	37/8	1/4	1¼	33/8	61/16	31/2	83/8	101/2
6	3	3	2¾-12	2¼-12	3½	3.749	1	25/8	43/4	27/8	1/4	1¼	33/8	61/16	31/2	83/8	101/2
	4	3½	3¼-12	2½-12	3½	4.249	1	3	43/4	33/8	1/4	1¼	33/8	61/16	31/2	83/8	101/2

◆◆ Dimension XI to be specified by customer.

For Cylinder Division Plant Locations – See Page II.



B

**Spherical Bearing Mounting
Style SB
1 1/2" to 6" Bore Sizes**

**Series 2H
Heavy Duty Hydraulic Cylinders**

Bore	Max. Op. PSI†
1 1/2	1250
2	2200
2 1/2	1450
3 1/4	1500
4	1850
5	2000
6	1800

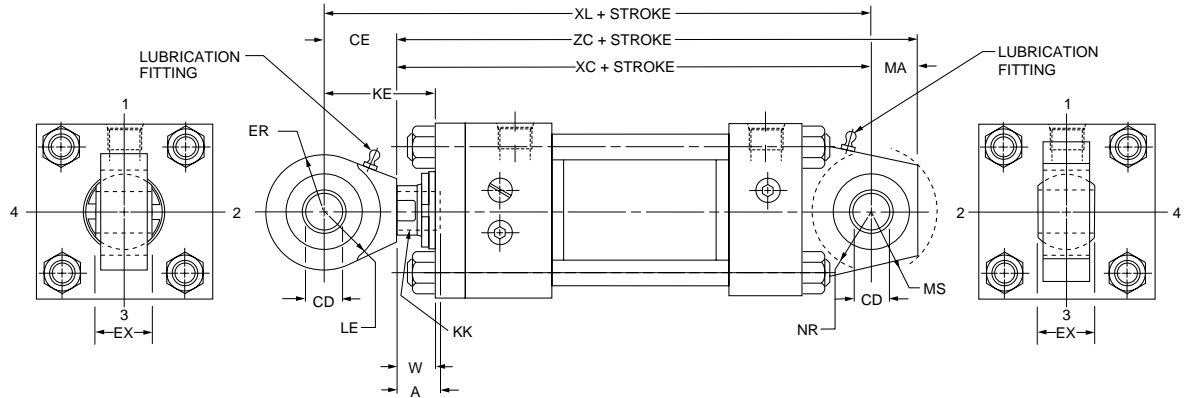

Table 1 — Dimensions

Bore	Rod No.	Rod Dia. MM	Thread		A	W	Add Stroke			KE	CD*	CE	ER	EX	LE	MA	MS	NR
			Style 9 KK	Style 7 KK			XC	XL	ZC									
1 1/2	1 (Std.)	5/8	7/16-20	—	3/4	5/8	6 3/8	7 1/4	7 1/8	11 1/2	-.0005	7/8	13/16	7/16	3/4	3/4	15/16	5/8
	2	1	—	7/16-20	3/4	1	6 3/4	7 5/8	7 1/2	17/8	.5000							
2	1 (Std.)	1	3/4-16	—	1 1/8	3/4	7 1/4	8 1/2	8 1/4	2	-.0005	1 1/4	1 1/8	2 1/32	1 1/16	1	1 3/8	1
	2	1 3/8	—	3/4-16	1 1/8	1	7 1/2	8 3/4	8 1/2	2 1/4	.7500							
2 1/2	1 (Std.)	1	3/4-16	—	1 1/8	3/4	7 3/8	8 5/8	8 3/8	2	-.0005	1 1/4	1 1/8	2 1/32	1 1/16	1	1 3/8	1
	2	1 3/4	—	3/4-16	1 1/8	1 1/4	7 7/8	9 1/8	8 7/8	2 1/2	.7500							
3 1/4	1 (Std.)	1 3/8	1-14	—	1 5/8	7/8	8 5/8	10 1/2	9 7/8	2 3/4	-.0005	1 7/8	1 1/4	7/8	1 7/16	1 1/4	1 11/16	1 1/4
	2	2	—	1-14	1 5/8	1 1/4	9	10 7/8	10 1/4	3 1/8	1.0000							
4	1 (Std.)	1 3/4	1 1/4-12	—	2	1	9 3/4	11 7/8	11 5/8	3 1/8	-.0005	2 1/8	1 11/16	1 3/16	1 7/8	1 7/8	2 7/16	1 5/8
	2	2 1/2	—	1 1/4-12	2	1 3/8	10 1/8	12 1/4	12	3 1/2	1.3750							
5	1 (Std.)	2	1 1/2-12	—	2 1/4	1 1/8	10 1/2	13	13	3 5/8	-.0005	2 1/2	2 1/16	1 17/32	2 1/8	2 1/2	2 7/8	2 1/16
	2	3 1/2	—	1 1/2-12	2 1/4	1 3/8	10 3/4	13 1/4	13 1/4	3 7/8	1.7500							
6	1 (Std.)	2 1/2	1 7/8-12	—	3	1 1/4	12 1/8	14 7/8	14 5/8	4	-.0005	2 3/4	2 1/2	1 3/4	2 1/2	2 1/2	3 5/16	2 3/8
	2	4	—	1 7/8-12	3	1 1/4	12 1/8	14 7/8	14 5/8	4	2.0000							

†Maximum operating pressure at 4:1 design factor is based on tensile strength of material. Pressure ratings are based on standard commercial bearing ratings.
 Note: for additional dimensions see Series 2H Style BB mount.
 Rod No. 1 is standard.
 *Dimension "CD" is hole diameter.

Recommended maximum swivel angle on each side of the cylinder centerline.

**Mounting Information
Head End Mounting**

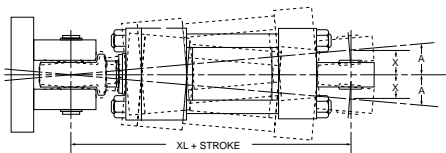

Cap End Mounting

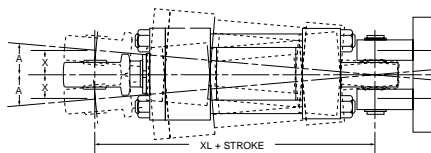

Table 1

Bore	Head End Mounted		Cap End Mounted	
	Angle a	Tan. of a	Angle a	Tan. of a
1 1/2	2°	.035	2°	.035
2	2 1/2°	.044	4 1/2°	.079
2 1/2	2 1/2°	.044	4 1/2°	.079
3 1/4	3°	.052	3°	.052
4	2 1/2°	.044	3°	.052
5	3°	.052	3°	.052
6	3°	.052	3°	.052

Note: Dimension X is the maximum off center mounting of the cylinder. To determine dimension X for various stroke lengths multiply the distance between pivot pin holes by tangent of angle a. For extended position use X = XL times 2X stroke.

For additional information – call your local Parker Cylinder Distributor.

Series 2H Heavy Duty Hydraulic Cylinders

Cylinder Accessories Spherical Bearing Mounting Style SB

Parker offers a complete range of Cylinder Accessories to assure you of the greatest versatility in present or future cylinder applications. Accessories offered for the

respective cylinder include the Rod Eye, Pivot Pin and Clevis Bracket. To select the proper part number for any desired accessory refer to the charts below.

Spherical Rod Eye

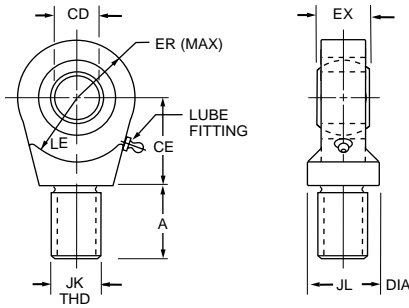

Bore Sizes	Series 2H	1 1/2	2 & 2 1/2	3 1/4	4	5	6
Rod Eye	Part No.	132290	132291	132292	132293	132294	132295
	CD	.5000-.0005	.7500-.0005	1.0000-.0005	1.3750-.0005	1.7500-.0005	2.0000-.0005
	A	1 1/16	1	1 1/2	2	2 1/8	2 7/8
	CE	7/8	1 1/4	1 7/8	2 1/8	2 1/2	2 3/4
	EX	7/16	2 1/32	7/8	1 3/16	1 17/32	1 3/4
	ER	13/16	1 1/8	1 1/4	1 11/16	2 1/16	2 1/2
	LE	3/4	1 1/16	1 7/16	1 7/8	2 1/8	2 1/2
	JK	7/16-20	3/4-16	1-14	1 1/4-12	1 1/2-12	1 7/8-12
	JL	7/8	1 5/16	1 1/2	2	2 1/4	2 3/4
	LOAD CAPACITY LBS.	2644	9441	16860	28562	43005	70193

Order to fit Piston Rod Thread Size.

Pivot Pin

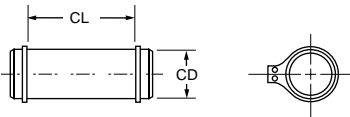

Bore Sizes	Series 2H	1 1/2	2 & 2 1/2	3 1/4	4	5	6
Pivot Pin	Part No.	83962	83963	83964	83965	83966	83967
	CD	.4997-.0004	.7497-.0005	.9997-.0005	1.3746-.0006	1.7496-.0006	1.9996-.0007
	CL	1 9/16	2 1/32	2 1/2	3 5/16	4 7/32	4 15/16
	SHEAR CAPACITY LBS.	8600	19300	34300	65000	105200	137400

Pivot Pins are furnished with (2) Retainer Rings.

Clevis Bracket

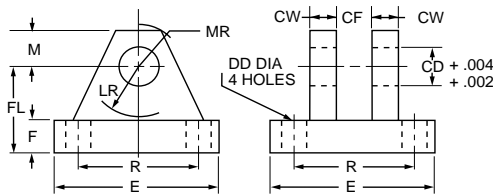

Order to fit Mounting Plate or Rod Eye.

Bore Sizes	Series 2H	1 1/2	2 & 2 1/2	3 1/4	4	5	6
Clevis Bracket	Part No.	83947	83948	83949	83950	83951	83952
	CD	1/2	3/4	1	1 3/8	1 3/4	2
	CF	7/16	2 1/32	7/8	1 3/16	1 17/32	1 3/4
	CW	1/2	5/8	3/4	1	1 1/4	1 1/2
	DD	13/32	17/32	17/32	2 1/32	2 9/32	2 9/32
	E	3	3 3/4	5 1/2	6 1/2	8 1/2	10 5/8
	F	1/2	5/8	3/4	7/8	1 1/4	1 1/2
	FL	1 1/2	2	2 1/2	3 1/2	4 1/2	5
	LR	15/16	1 3/8	1 11/16	2 7/16	2 7/8	3 5/16
	M	1/2	7/8	1	1 3/8	1 3/4	2
	MR	5/8	1	1 3/16	1 5/8	2 1/16	2 3/8
	R	2.05	2.76	4.10	4.95	6.58	7.92
	LOAD CAPACITY LBS.	5770	9450	14300	20322	37800	50375

For Cylinder Division Plant Locations – See Page II.

Double Rod Models
1 1/2" to 6" Bore Sizes

Series 2H Heavy Duty Hydraulic Cylinders

How to Use Double Rod Cylinder Dimensioned Drawings

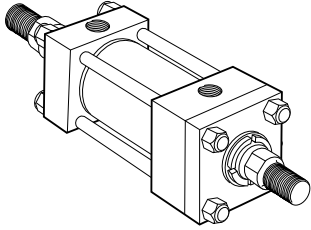

1 1/2" to 6" Bores

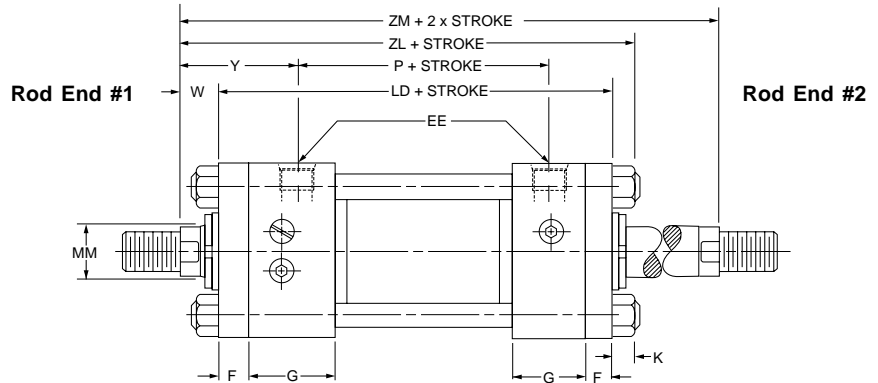

Mounting Styles for Single Rod Models	Mounting Styles for Corresponding Double Rod Models*	Dimensions Shown on This Page Supplement Dimensions on Pages Listed Below
		1 1/2" - 6" Bores Page No.
T	KT	44
TB	KTB	44
TD	KTD	44
J	KJ	46
JB	KJB	46
JJ	KJJ	46
C	KC	50
E	KE	50
F	KF	50
CB	KCB	52
G	KG	52
D	KD	54
DD	KDD‡	54

To determine dimensions for a double rod cylinder, first refer to the desired single rod mounting style cylinder shown on preceding pages of this catalog. (See table at left.) After selecting necessary dimensions from that drawing, return to this page supplement the single rod dimensions with those shown on drawing at right and dimension table below. Note that double rod cylinders have a head (Dim. G) at both ends and that dimension LD replaces LB and ZL replaces ZB, etc. The double rod dimensions differ from, or

are in addition to those for single rod cylinders shown on preceding pages and provide the information needed to completely dimension a double rod cylinder.

On a double rod cylinder where the two rod ends are different, be sure to clearly state which rod end is to be assembled at which end. Port position 1 is standard. If other than standard, specify pos. 2, 3 or 4 when viewed from rod end #1 only. See port position information in Section C.

*If only one end of these Double Rod Cylinders is to be cushioned, be sure to specify clearly which end this will be.

‡Specify XI dimension from rod end #1.

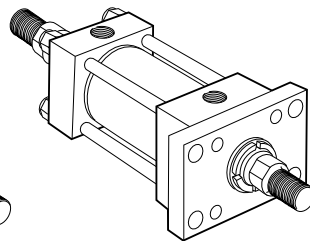
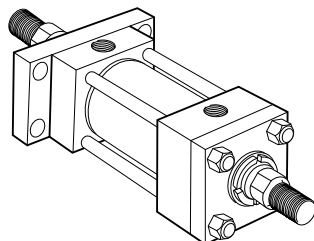
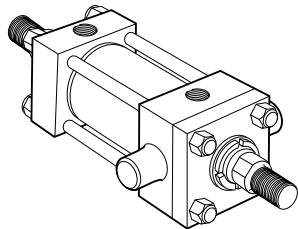
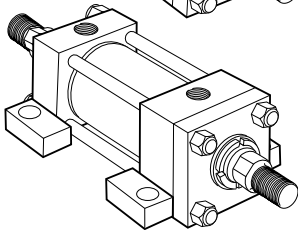
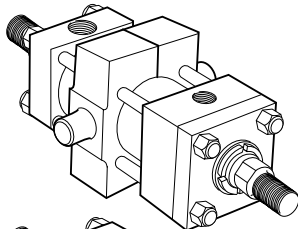

All dimensions are in inches and apply to Code 1 rod sizes only. For alternate rod sizes, determine all envelope dimensions (within LD dim.) as described above and then use appropriate rod end dimensions for proper rod size from single rod cylinder.

Bore	Rod No.	Rod Dia. MM	Add stroke											Add 2X Stroke
			LD	ZL	SA _K	XA _K	ZA _K	SN _K	SS _K	SE _K	XE _K	ZE _K	ZM	
1 1/2	1	5/8	5 5/8	6 1/4	7 5/8	7 1/4	7 5/8	2 7/8	4 1/8	7 3/8	7 1/8	7 1/2	6 7/8	
2	1	1	6 1/8	6 7/8	8 5/8	8 1/8	8 5/8	2 7/8	3 7/8	8	7 13/16	8 5/16	7 5/8	
2 1/2	1	1	6 1/4	7	8 5/8	8 3/16	8 3/4	3	3 5/8	8 1/8	7 15/16	8 7/16	7 3/4	
3 1/4	1	1 3/8	7 1/4	8 1/8	10 7/8	9 15/16	10 5/8	3 1/2	4 3/8	9 1/2	9 1/4	9 7/8	9	
4	1	1 3/4	7 3/4	8 3/4	12	10 7/8	11 3/4	3 3/4	4 1/4	10	9 7/8	10 1/2	9 3/4	
5	1	2	8 1/4	9 3/8	12 1/2	11 1/2	12 3/8	4 1/4	4 3/4	11 1/4	10 7/8	11 5/8	10 1/2	
6	1	2 1/2	9 3/8	10 5/8	14 1/4	13 1/16	14 1/8	4 7/8	5 1/8	12 3/4	12 5/16	13 3/16	11 7/8	
Replaces: On single rod mounting styles:			LB	ZB	SA	XA	ZA	SN	SS	SE	XE	ZE	—	
			All Mtg. Styles			CB		F	C,E		G		All Mtgs.	

For additional information – call your local Parker Cylinder Distributor.

NOTES

B

For Cylinder Division Plant Locations – See Page II.

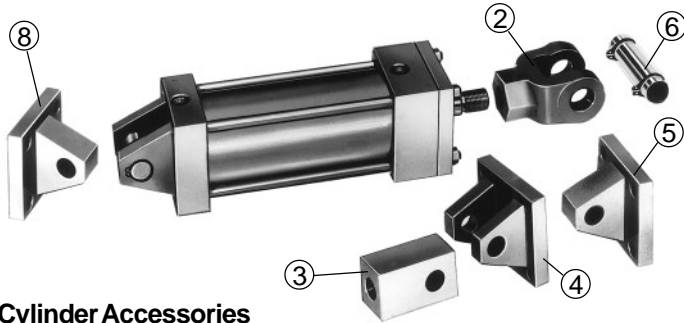

Cylinder Accessories

Parker offers a complete range of cylinder accessories to assure you of greatest versatility in present or future cylinder applications.

Rod End Accessories

Accessories offered for the rod end of the cylinder include Rod Clevis, Eye Bracket, Knuckle, Clevis Bracket and Pivot Pin. To select the proper part number for any desired accessory, refer to Chart A below and look opposite the thread size of the rod end as indicated in the first column. The Pivot Pins, Eye Brackets and Clevis Brackets are listed opposite the thread size which their mating Knuckles or Clevises fit.

Chart A

Thread Size	Mating Parts			Mating Parts			Alignment Coupler
	Rod Clevis	Eye Bracket	Pin	Knuckle	Clevis Bracket	Pin	
5/16-24	51221	74077	—	74075	74076	74078	134757 0031
7/16-20	50940	69195	68368	69089	69205	68368	134757 0044
1/2-20	50941	69195	68368	69090	69205	68368	134757 0050
3/4-16	50942	69196	68369	69091	69206	68369	134757 0075
3/4-16	133284	69196	68369	69091	69206	68369	134757 0075
7/8-14	50943	*85361	68370	69092	69207	68370	134757 0088
1-14	50944	*85361	68370	69093	69207	68370	134757 0100
1-14	133285	*85361	68370	69093	69207	68370	134757 0100
1 1/4-12	50945	69198	68371	69094	69208	68371	134757 0125
1 1/4-12	133286	69198	68371	69094	69208	68371	134757 0125
1 1/2-12	50946	*85362	68372	69095	69209	68372	133739 0150
1 3/4-12	50947	*85363	68373	69096	69210	69215	133739 0175
1 7/8-12	50948	*85363	68373	69097	69210	69215	133739 0188
2 1/4-12	50949	*85364	68374	69098	69211	68374	Consult Factory
2 1/2-12	50950	*85365	68375	69099	69212	68375	
2 3/4-12	50951	*85365	68375	69100	69213	69216	
3 1/4-12	50952	73538	73545	73536	73542	73545	
3 1/2-12	50953	73539	73547	73437	73542	73545	
4-12	50954	73539	73547	73438	73543	82181	

For alignment coupler dimensions, see section C.

*Cylinder accessory dimensions conform to NFPA recommended standard NFPA/T3.6.8 R1-1984, NFPA recommended standard fluid power systems — cylinder — dimensions for accessories for cataloged square head industrial types. Parker adopted this standard in April, 1985. Eye Brackets or Mounting Plates shipped before this date may have different dimensions and will not necessarily interchange with the NFPA standard. For dimensional information on older style Eye Brackets or Mounting Plates consult Drawing #144805 or previous issues of this catalog.

Accessory Load Capacity

The various accessories on this and the following pages have been load rated for your convenience. The load capacity in lbs., shown on the following page is the recommended maximum load for that accessory based on a 4:1 design factor in tension. (Pivot Pin is rated in shear.) Before specifying, compare the actual load or the tension (pull) force at maximum operating pressure of the cylinder with the load capacity of the accessory you plan to use. If load or pull force of cylinder exceeds load capacity of accessory, consult factory.

Chart B

Mtg. Plate Part No.	Series 2H Bore Size
69195	1 1/2"
69196	2", 2 1/2"
*85361	3 1/4"
69198	4"
*85362	5"
*85363	6"

Mounting Plates

Mounting Plates for Style BB (clevis mounted) cylinders are offered. To select proper part number for your application, refer to Chart B, above right.

② Female Rod Clevis

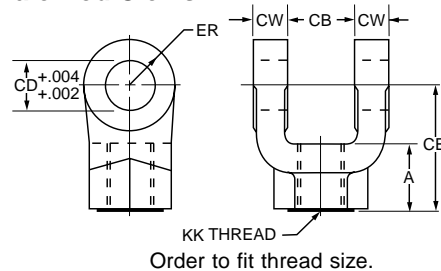

③ Knuckle (Female Rod Eye)

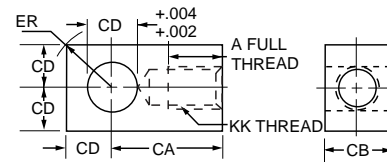

④ Clevis Bracket for Knuckle

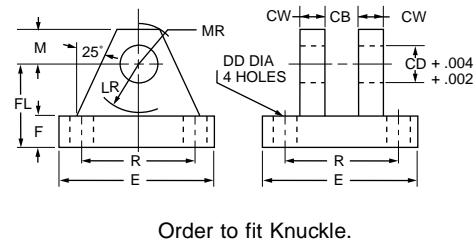

⑧ Mounting Plate or ⑤ Eye Bracket

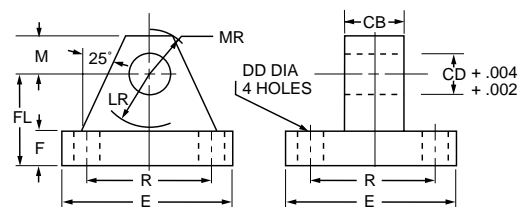

- When used to mate with the Rod Clevis, select from Chart A.
- When used to mount the Style BB cylinders, select from the Mounting Plate Selection Table. See Chart B at lower left.

⑥ Pivot Pin

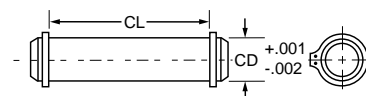

- Pivot Pins are furnished with Clevis Mounted Cylinders as standard.
- Pivot Pins are furnished with (2) Retainer Rings.
- Pivot Pins must be ordered as separate item if to be used with Knuckles, Rod Clevises, or Clevis Brackets.

For additional information – call your local Parker Cylinder Distributor.

Series 2H Heavy Duty Hydraulic Cylinders

Cylinder Accessories

	Female Rod Clevis Part Number																		
	51221†	50940	50941	50942	133284	50943	50944	133285	50945	133286	50946	50947	50948	50949	50950	50951	50952	50953	50954
A	13/16	3/4	3/4	1 1/8	1 1/8	1 5/8	1 5/8	1 5/8	1 7/8	2	2 1/4	3	3	3 1/2	3 1/2	3 1/2	3 1/2††	4††	4††
CB	1 1/32	3/4	3/4	1 1/4	1 1/4	1 1/2	1 1/2	1 1/2	2	2	2 1/2	2 1/2	2 1/2	3	3	3	4	4 1/2	4 1/2
CD	5/16	1/2	1/2	3/4	3/4	1	1	1	1 3/8	1 3/8	1 3/4	2	2	2 1/2	3	3	3 1/2	4	4
CE	2 1/4	1 1/2	1 1/2	2 1/8	2 3/8	2 15/16	2 15/16	3 1/8	3 3/4	4 1/8	4 1/2	5 1/2	5 1/2	6 1/2	6 3/4	6 3/4	7 3/4	8 13/16	8 13/16
CW	1 3/64	1/2	1/2	5/8	5/8	3/4	3/4	3/4	1	1	1 1/4	1 1/4	1 1/4	1 1/2	1 1/2	1 1/2	2	2 1/4	2 1/4
ER	1 9/64	1/2	1/2	3/4	3/4	1	1	1	1 3/8	1 3/8	1 3/4	2	2	2 1/2	2 3/4	2 3/4	3 1/2	4	4
KK	5/16-24	7/16-20	1/2-20	3/4-16	3/4-16	7/8-14	1-14	1-14	1 1/4-12	1 1/4-12	1 1/2-12	1 3/4-12	1 7/8-12	2 1/4-12	2 1/2-12	2 3/4-12	3 1/4-12	3 1/2-12	4-12
Load Capacity Lbs. Ⓞ	2600	4250	4900	11200	11200	18800	19500	19500	33500	33500	45600	65600	65600	98200	98200	98200	156700	193200	221200

	Knuckle Part Number																
	74075	69089	69090	69091	69092	69093	69094	69095	69096	69097	69098	69099	69100	73536	73437	73438	73439
A	3/4	3/4	3/4	1 1/8	1 1/8	1 5/8	2	2 1/4	2 1/4	3	3 1/2	3 1/2	3 5/8	4 1/2	5	5 1/2	5 1/2
CA	1 1/2	1 1/2	1 1/2	2 1/16	2 3/8	2 13/16	3 7/16	4	4 3/8	5	5 13/16	6 1/8	6 1/2	7 5/8	7 5/8	9 1/8	9 1/8
CB	7/16	3/4	3/4	1 1/4	1 1/2	1 1/2	2	2 1/2	2 1/2	2 1/2	3	3	3 1/2	4	4	4 1/2	5
CD	7/16	1/2	1/2	3/4	1	1	1 3/8	1 3/4	2	2	2 1/2	3	3	3 1/2	3 1/2	4	4
ER	1 9/32	2 3/32	2 3/32	1 1/16	1 7/16	1 7/16	1 31/32	2 1/2	2 27/32	2 27/32	3 9/16	4 1/4	4 1/4	4 31/32	4 31/32	5 11/16	5 11/16
KK	5/16-24	7/16-20	1/2-20	3/4-16	7/8-14	1-14	1 1/4-12	1 1/2-12	1 3/4-12	1 7/8-12	2 1/4-12	2 1/2-12	2 3/4-12	3 1/4-12	3 1/2-12	4-12	4 1/2-12
Load Capacity Lbs. Ⓞ	3300	5000	5700	12100	13000	21700	33500	45000	53500	75000	98700	110000	123300	161300	217300	273800	308500

	Clevis Bracket for Knuckle Part Number													
	74076	69205	69206	69207	69208	69209	69210	69211	69212	69213	73542	73543	73544	
CB	1 5/32	3/4	1 1/4	1 1/2	2	2 1/2	2 1/2	3	3	3 1/2	4	4 1/2	5	
CD	7/16	1/2	3/4	1	1 3/8	1 3/4	2	2 1/2	3	3	3 1/2	4	4	
CW	3/8	1/2	5/8	3/4	1	1 1/4	1 1/2	1 1/2	1 1/2	1 1/2	2	2	2	
DD	1 7/64	1 13/32	1 17/32	2 1/32	2 1/32	2 29/32	3 1/16	3 13/16	4 1/16	4 15/16	5 1/16	5 13/16	6 1/16	
E	2 1/4	3 1/2	5	6 1/2	7 1/2	9 1/2	12 3/4	12 3/4	12 3/4	12 3/4	15 1/2	17 1/2	17 1/2	
F	3/8	1/2	5/8	3/4	7/8	7/8	1	1	1	1	1 11/16	1 15/16	1 15/16	
FL	1	1 1/2	1 7/8	2 1/4	3	3 5/8	4 1/4	4 1/2	6	6	6 11/16	7 11/16	7 11/16	
LR	5/8	3/4	1 3/16	1 1/2	2	2 3/4	3 3/16	3 1/2	4 1/4	4 1/4	5	5 3/4	5 3/4	
M	3/8	1/2	3/4	1	1 3/8	1 3/4	2 1/4	2 1/2	3	3	3 1/2	4	4	
MR	1/2	5/8	2 9/32	1 1/4	1 21/32	2 7/32	2 25/32	3 1/8	3 19/32	3 19/32	4 1/8	4 7/8	4 7/8	
R	1.75	2.55	3.82	4.95	5.73	7.50	9.40	9.40	9.40	9.40	12.00	13.75	13.75	
Load Capacity Lbs. Ⓞ	3600	7300	14000	19200	36900	34000	33000	34900	33800	36900	83500	102600	108400	

	Eye Bracket and Mounting Plate Part Number											
	74077	69195	69196	85361*	69198	85362*	85363*	85364*	85365*	73538	73539	
CB	5/16	3/4	1 1/4	1 1/2	2	2 1/2	2 1/2	3	3	4	4 1/2	
CD	5/16	1/2	3/4	1	1 3/8	1 3/4	2	2 1/2	3	3 1/2	4	
DD	1 7/64	1 13/32	1 17/32	2 1/32	2 1/32	2 29/32	3 1/16	3 13/16	4 1/16	4 15/16	5 1/16	
E	2 1/4	2 1/2	3 1/2	4 1/2	5	6 1/2	7 1/2	8 1/2	9 1/2	12 5/8	14 7/8	
F	3/8	3/8	5/8	7/8	7/8	1 1/8	1 1/2	1 3/4	2	1 11/16	1 15/16	
FL	1	1 1/8	1 7/8	2 3/8	3	3 3/8	4	4 3/4	5 1/4	5 11/16	6 7/16	
LR	5/8	3/4	1 1/4	1 1/2	2 1/8	2 1/4	2 1/2	3	3 1/4	4	4 1/2	
M	3/8	1/2	3/4	1	1 3/8	1 3/4	2	2 1/2	3	3 1/2	4	
MR	1/2	9/16	7/8	1 1/4	1 5/8	2 1/8	2 7/16	3	3 1/4	4 1/8	5 1/4	
R	1.75	1.63	2.55	3.25	3.82	4.95	5.73	6.58	7.50	9.62	11.45	
Load Capacity Lbs. Ⓞ	1700	4100	10500	20400	21200	49480	70000	94200	121900	57400	75000	

	Pivot Pin Part Number													
	74078	68368	68369	68370	68371	68372	68373	69215	68374	68375	69216	73545	82181	73547
CD	7/16	1/2	3/4	1	1 3/8	1 3/4	2	2	2 1/2	3	3	3 1/2	4	4
CL	1 5/16	1 7/8	2 5/8	3 1/8	4 1/8	5 3/16	5 3/16	5 11/16	6 3/16	6 1/4	6 3/4	8 1/4	8 5/8	9
Shear Capacity Lbs. Ⓞ	6600	8600	19300	34300	65000	105200	137400	137400	214700	309200	309200	420900	565800	565800

*Cylinder accessory dimensions conform to NFPA recommended standard NFPA/T3.6.8 R1-1984, NFPA recommended standard fluid power systems — cylinder — dimensions for accessories for cataloged square head industrial types. Parker adopted this standard in April, 1985. Eye Brackets or Mounting Plates shipped before this date may have different dimensions and will not necessarily interchange with the NFPA standard. For dimensional information on older style Eye Brackets or Mounting Plates consult Drawing #144805 or previous issues of this catalog.

Ⓞ See Accessory Load Capacity note on previous page.

• These sizes supplied with cotter pins.

† Includes Pivot Pin.

Consult appropriate cylinder rod end dimensions for compatibility.

For Cylinder Division Plant Locations – See Page II.



Series 2H Heavy Duty Hydraulic Cylinders

How to Order

How to Order Series “2H” Cylinders

When ordering Series 2H cylinders, please review the following:

Note: Duplicate cylinders can be ordered by giving the SERIAL NUMBER from the nameplate of the original cylinder. Factory records supply a quick positive identification.

Piston Rods: Specify rod code number based on diameter. Give thread style number for a standard thread or specify dimensions. See “Style 3 Rod End” below.

Cushions: If cushions are required specify according to the model number on the next page. If the cylinder is to have a double rod and only one cushion is required, be sure to specify clearly which end of the cylinder is to be cushioned.

Special Modifications: Additional information is required on orders for cylinders with special modifications. This is best handled with descriptive notes. For further information, consult factory.

Additional Lipseal® Piston (if desired): Parker Lipseal® pistons are offered as an option at no extra cost in the Series 2H cylinders. With this feature, zero leakage under static holding conditions is attained. Call out “with Lipseal piston” if this type of piston is desired. If not specified, the ring type piston will be furnished. Hi Load piston seals are available for an additional charge. Refer to the beginning of Section C for the benefits of this piston seal assembly.

Fluid Medium: Series 2H hydraulic cylinders are equipped with seals for use with hydraulic oil. If other than hydraulic oil will be used, specify class of fluid (See Catalog section C.)

Water Service Modifications

Standard – When requested, Parker can supply Series 2H cylinders with standard modifications that make the cylinders more nearly suitable for use with water as the fluid medium. The modifications include chrome-plated cylinder bore; electroless nickel-plated, non-wearing internal surfaces; Lipseal style piston, Buna N Seals and chrome-plated, stainless steel piston rod. On orders for water service cylinders, be sure to specify the maximum operating pressure.

(These factors must be taken into account because of the lower tensile strength of stainless steels available for use in piston rods.)

Warranty– Parker will warrant Series 2H cylinders modified for water service to be free of defects in materials or workmanship. On the other hand, Parker cannot accept responsibility for premature failure of cylinder function, where failure is caused by corrosion, electrolysis or mineral deposits within the cylinder.

Class 1 Seals

Class 1 seals are the seals provided as standard in a cylinder assembly unless otherwise specified. For further information on fluid compatibility or operating limitations of all components, see section C.

For the 2H series cylinders the following make-up Class 1 Seals:

Primary Piston Rod Seal – Enhanced Polyurethane

Piston Rod Wiper – Nitrile

Piston Seals – Cast Iron Rings

Option – Nitrile lipseals with polymyte back-up washers

Option – Hi-Load. Filled P.T.F.E. seals with a nitrile expander

O-Rings – Nitrile (nitrile back-up washer when used)

Combination Mountings

Single Rod End The first mounting is the one called out on the head end of the cylinder. The second or subsequent mountings are called out as they appear in the assembly moving away from the rod end. Exception: When tie rod mountings are part of a combination, the model number should contain an “S” (Special) in the model code and a note in the body of the order clarifying the mounting arrangement. The “P” is used to define a thrust key and is not considered to be a mounting. However, it is located at the primary end.

Example: 4.00 CCBB2HLTS14AC x 10.000

Combination “C” mounting head only. “BB” mounting cap end

This cylinder is also cushioned at both ends.

Double Rod End In general, the model number is read left to right corresponding to the cylinder as viewed from left to right with the

primary end at rod end #1. See Double Rod Models information page in this section. For this option the piston rod number, piston rod end, and piston rod threads are to be specified for both ends. The simplest are for symmetric cylinders such as: TD, C, E, F, G, and CB mounts. All other mounting styles, the description of the first rod end will be at the mounting end. In the case of multiple mounts, the description of the first rod end will be at the primary mounting end. For “DD” mounts, the description of the first rod end will be the same location as the “XI” dimension.

Example: 4.00 KDD2HLT24A/18A x 10.000 XI=8

This is a center trunnion mounting cylinder with the XI dimension measured from the code 2 rod side of the cylinder which has the style 4 thread. The opposite end code 1 rod with the style 8 thread.

Style 3 Rod End

A style 3 rod end indicates a special rod end configuration. All special piston rod dimensions must have **all three:** KK; A; W/WF or LA/LAF specified with the rod fully retracted. A sketch or drawing should be submitted for rod ends requiring special machining such as snap ring grooves, keyways, tapers, multiple diameters, etc. It is good design practice to have this machining done on a diameter at least 0.065 inches smaller than the piston rod diameter. This allows the piston rod to have a chamfer preventing rod seal damage during assembly or

maintenance. Standard style 55 rod ends with a longer than standard WG dimension should call out a style 3 rod end and the note: **same as 55 except WG=_____**. A drawing should be submitted for special 55 rod ends that have specific tolerances or special radii. Special rod ends that have smaller than standard male threads, larger than standard female threads, or style 55 rod ends with smaller than standard AF or AE dimensions are to be reviewed by Engineering for proper strength at operating pressure.

Service Policy

On cylinders returned to the factory for repairs, it is standard policy for the Cylinder Division to make such part replacements as will put the cylinder in as good as new condition. Should the condition of the returned cylinder be such that expenses for repair would exceed the costs of a new one, you will be notified.

Address all correspondence and make shipments to, Service Department at your nearest regional plant listed in the pages of this catalog.

Certified Dimensions

Parker Cylinder Division guarantees that all cylinders ordered from this catalog will be built to dimensions shown. All dimensions are certified to be correct, and thus it is not necessary to request certified drawings.

For additional information – call your local Parker Cylinder Distributor.

Series 2H Heavy Duty Hydraulic Cylinders

Model Numbers

Series “2H” Model Numbers – How to Develop Them – How to “Decode” Them

Parker Series 2H cylinders can be completely and accurately described by a model number consisting of coded symbols. To develop a model number, select only those symbols that represent

the cylinder required, and place them in the sequence indicated below.

Note: Page numbers with a letter prefix, ie: C77, are located in section C of this catalog.

Feature	Description	Page No.	Symbol
Bore*	Specify in inches		
Cushion-Head	Used only if cushion required	C94,42 & 43	C
Double-Rod	Used only if double-rod cylinder is required	58	K
Mounting* Style	Head Tie Rods Extended	44	TB
	Cap Tie Rods Extended	44	TC
	Both End Tie Rods Extended	44	TD
	Head Rectangular Flange	46	J
	Head Square Flange	46	JB
	Head Rectangular	46	JJ
	Cap Rectangular Flange	48	H
	Cap Square Flange	48	HB
	Cap Rectangular	48	HH
	Side Lugs	50	C†
	Centerline Lugs	50	E
	Side Tapped	50	F†
	Side End Angles	52	CB
	Side End Lugs	52	GT
	Cap Fixed Clevis	52	BB
	Head Trunnion	54	D
	Cap Trunnion	54	DB
Intermediate Fixed Trunnion‡	54	DD	
Spherical Bearing	56	SB	
Modifications Mounting	Used only for Thrust Key (Styles C,F,G, & CB)	C93	P
	Used only for Manifold Port O-Ring Seal (Style C)	C91	M
Combination Mounting Style	Any Practical Mounting Style	–	As listed above
	Listed Above	–	–
Series*	Used in all 2H Model Numbers	–	-2H
Piston	Ring packed piston standard	–	C
	Used only for Lipseal® Piston	43	L
	Used only for Hi-Load Piston	43	K
Ports*	SAE Straight Thread O-Ring Port (Standard)	C89	T
	Used only for NPTF (Dry Seal Pipe Thread)	C89	U
	Used only for BSP (Parallel Thread ISO 228)	C89	R
	Used only for SAE Flange Ports (3000 psi)	C89	P
	Used only for BSPT (Taper Thread)	C89	B
	Used only for Metric Thread	C89	G
	Used only for Metric Thread per ISO 6149	C89	Y
Common Modifications	High Water Content Fluid	C83	J
	Nut Retained Piston	43	F
	Fluorocarbon Seals	C83	V
	Water Service EPR Seals	C83 C83	W X
Special Modifications	Used only if special Modifications are required:		
	Oversize Ports	C91	S
	Port Position Change	C89	
	Special Seals	C83	
	Stop Tube*	C95	
	Stroke Adjuster Tie Rod Supports	C93 C93	
Piston Rod* Number	For Single Rod Cylinders, select one only. Refer to Rod number listing, Table 2, Pages 44 through 55	–	1
	See chart in Section C for minimum piston rod diameter	–	2
		–	3
		–	4
		–	5
		–	6
		–	7
		–	8
		–	9
		–	0
Piston* Rod End	Select:		
	Style 4 Small Male	C92	4
	Style 7 Female Thread for Spherical Rod Eye	B56	7
	Style 8 Intermediate Male	C92	8
	Style 9 Short Female	C92	9
Style 55 Rod End for Flange Coupling	C19	55	
Style 3 Special (Specify)	C92	3	
Piston Rod Alternate Thds.	Used only for stud two times longer than standard.	C92	2
Piston Rod* Threads	UNF Standard	C92	A
	BSF (British Fine)	C92	W
	Metric	C92	M
Cushion-Cap	Used only if cushion required	C94, 42 & 43	C
Stroke* *	Specify in inches	C93	–

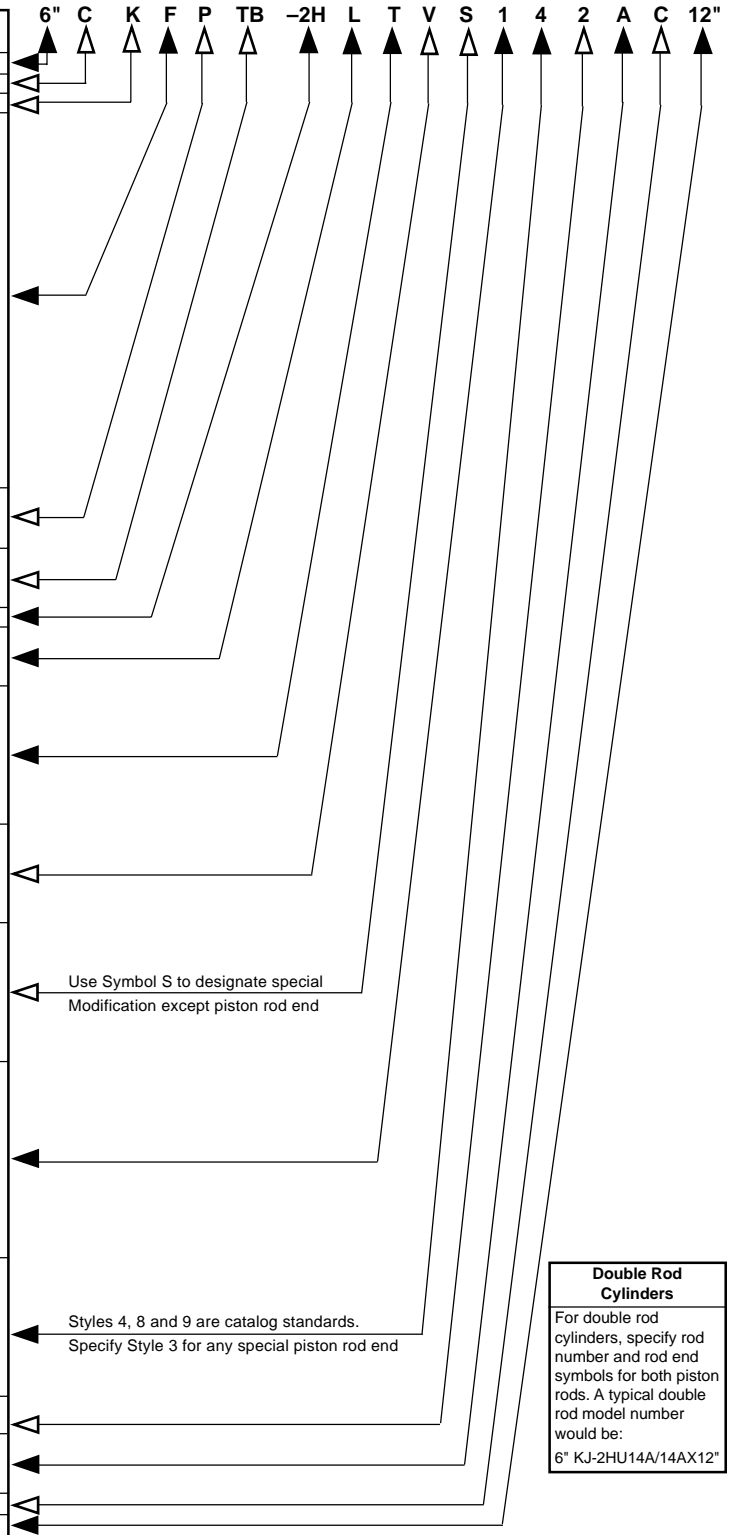

Double Rod Cylinders
For double rod cylinders, specify rod number and rod end symbols for both piston rods. A typical double rod model number would be:
6" KJ-2HU14A/14AX12"

*Required for Basic Cylinder Model Number
*In case of Stop Tube, call out Gross Stroke Length

†Cylinders with these mounting styles should have a minimum stroke length equal to or greater than their bore size.

Dark Arrows Indicate Basic Minimum Model Number
‡Specify XI dimension

For Cylinder Division Plant Locations – See Page II.



Parker TS-2000 seal designed to eliminate cylinder rod seal leakage.

Parker Series 2H Heavy Duty and Series 3L Medium Duty Hydraulic Cylinders with the TS-2000 seal offers positive protection against cylinder rod leakage under the most demanding applications.

The TS-2000 seal is the product of countless hours of research, development and extensive field testing and is only available on Parker Cylinders.

Based on the popular Parker Serrated Lipseal rod design, the TS-2000 incorporates the pressure-compensated, uni-directional characteristics of a U-cup with the multiple edge sealing effectiveness of compression-type stacked-packings.

The goal for the Parker team was to design a rod seal suitable for all types of applications, regardless of pressure profile. It had to be composed of a

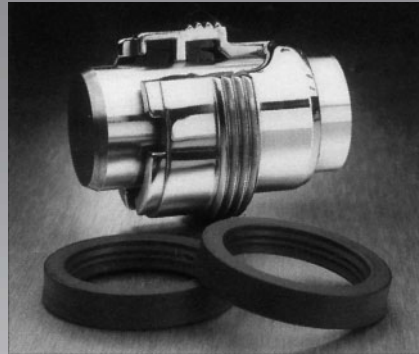

“Jewel” gland with wiperseal and TS-2000 cylinder rod seal.

material that would not react chemically with hydraulic fluids. And it had to produce better and more reliable “dry rod” performance than the standard serrated lip-seal design in a broad range of applications.

The result is the TS-2000 seal, designed especially to eliminate rod seal leakage in the most demanding applications. It features a special polyurethane material that will not react chemically with petroleum-based hydraulic fluid, is extremely resistant to abrasion and extrusion, and provides exceptional service life. It has more sealing edges than other seals on the market, which

in turn produces “dry rod” performance. The seal geometry was refined for maximum stability in the groove and has excellent performance characteristics throughout a broad range of pressures and piston rod velocities.

The Parker design team was successful!

TS-2000 rod seal has not failed in any of the test applications in the lab or on the job, no matter how tough or demanding.

For more information on the TS-2000 call or write your local Parker distributor or Parker Hannifin Corporation, Cylinder Division, 500 S. Wolf Road, Des Plaines, IL 60016, 847-298-2400.

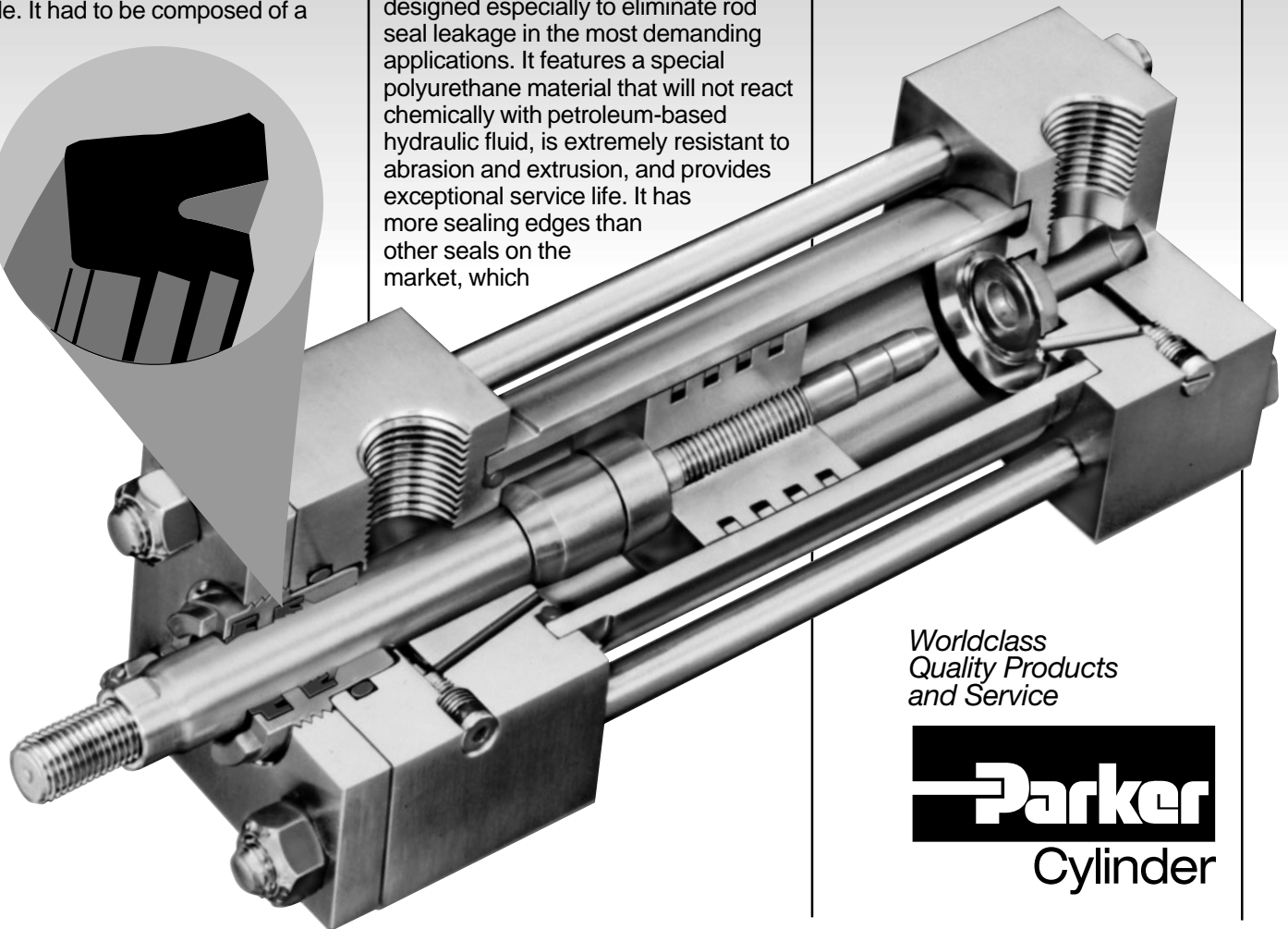
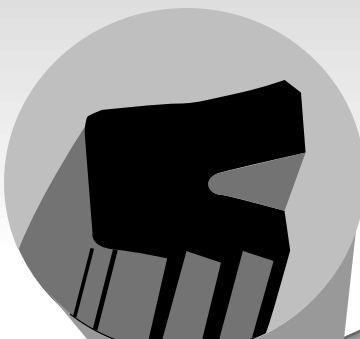

*Worldclass
Quality Products
and Service*

Parker
Cylinder

For additional information – call your local Parker Cylinder Distributor.