

The Broadest Range of Pneumatic Rotary Actuators

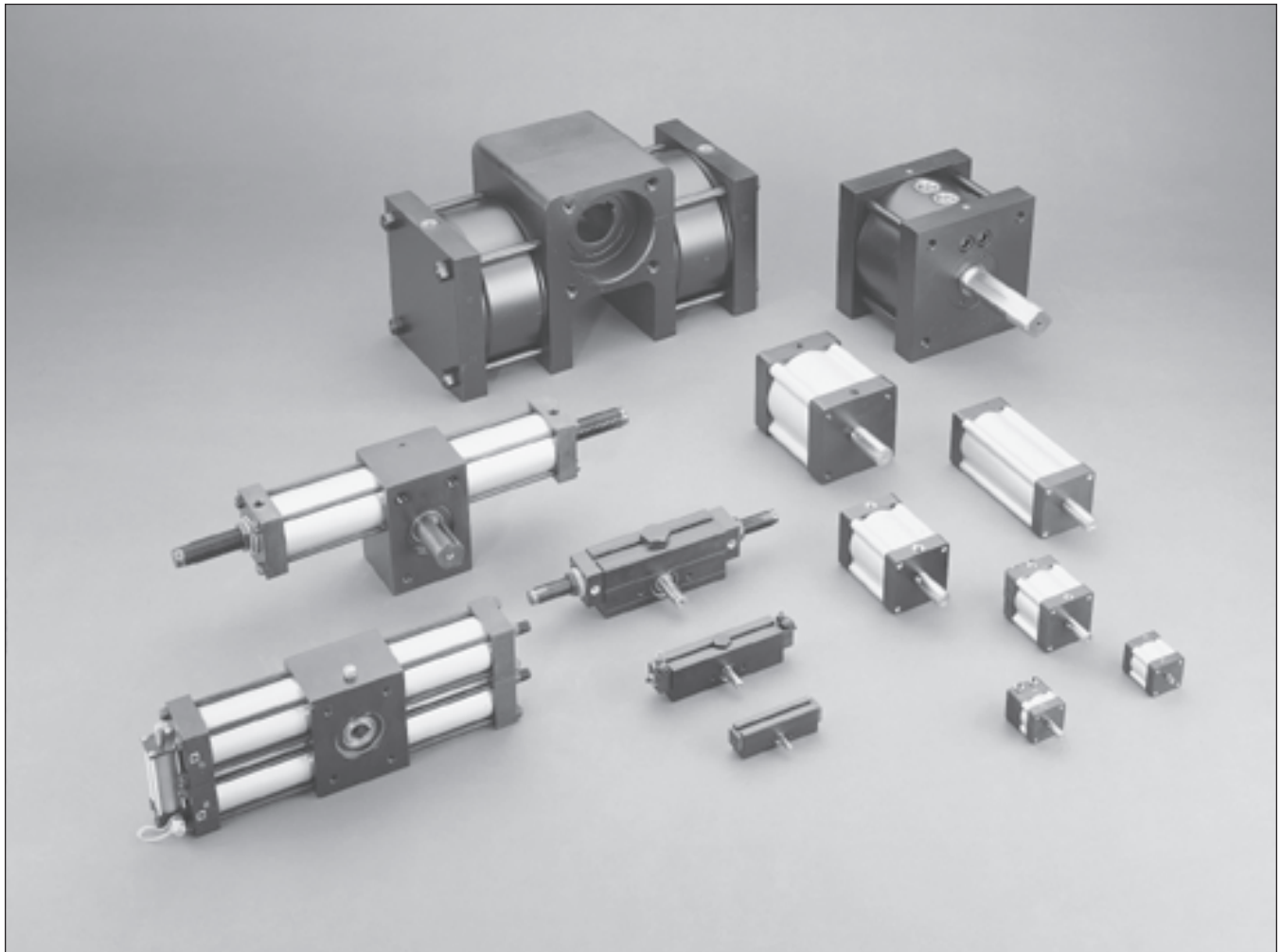

Rotary Actuators	PV
	WR
	XR
	PTR
	B671/F672
	HP

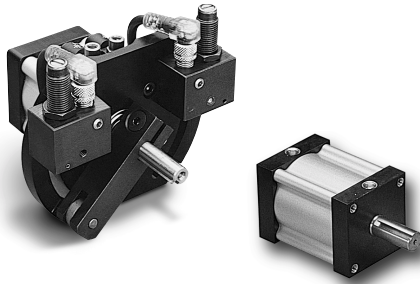

Parker . . . Leading the Industry

Parker combines many years of vane actuator experience with innovative product design to lead the industry in the development of reliable and efficient rotary actuators. When you specify Parker rotary vane actuators, you can rely on reduced maintenance costs and increased productivity.

Why Use Parker Vane Style Rotary Actuators?

- High torque output in a small package size
- Very economical for OEM applications
- Zero backlash allows precise positioning
- Provides uniform torque in both directions
- Simplicity of design
- Washdown compatible
- Performs under the most adverse ambient conditions
- Cleanroom compatible
- Guaranteed zero external leakage
- Will support radial and thrust loads
- Wide range of sizes

Where Can Parker Rotary Actuators Be Used?

- Material Handling
- Machine Tool
- Rubber and Plastics Machinery
- Robotics
- Packaging
- Valve Actuation
- Food Processing
- Electronics Manufacturing
- Conveyors

How Do Vane Actuators Work?

Parker vane actuators provide the maximum amount of output torque from the smallest possible envelope size. They convert air pressure into rotary motion for a wide variety of industrial applications. Two basic styles are available. Single vane models have a maximum rotation of 280°, while the double vane units produce twice the torque output from identical envelope dimensions and have a maximum rotation 100°.

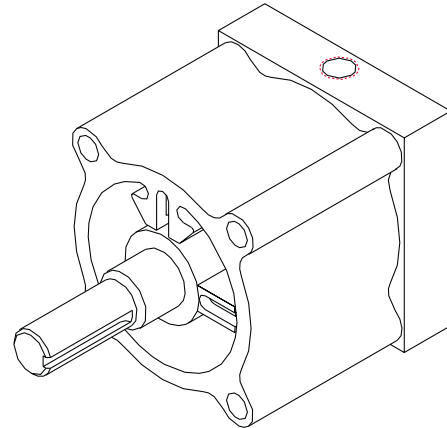

Single Vane - 280° Rotation

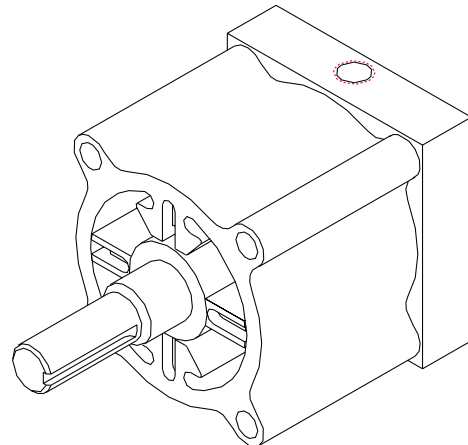

Double Vane - 100° Rotation

A short cylindrical chamber encloses a vane attached to a central shaft. Pressure is applied through a stationary barrier (stator) within the body to one side of the vane. The opposite side of the vane is connected to exhaust through the stator. This pressure overcomes seal friction and produces rotation of the vane and central shaft. Due to vane actuator design, there will always be some internal bypass in these units and therefore they should not be used as a brake to support loads.

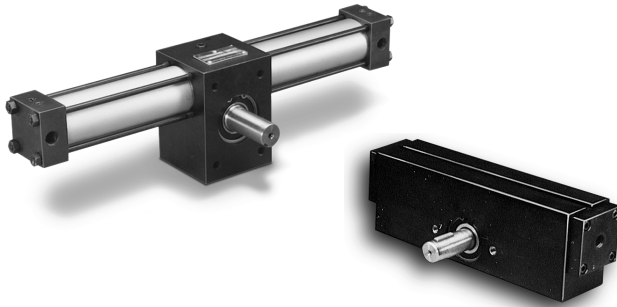

**Parker . . .
 Leading the Industry**

Parker leads the industry in developing new and innovative features to make rack and pinion rotary actuators more reliable, more efficient and safer than ever before. With a firm commitment to product quality and design research, Parker rotary actuators are continually being improved so that you can enjoy such benefits as long service life and increased productivity.

What Is a Rack & Pinion Rotary Actuator?

Parker rotary actuators convert fluid power into rotary motion for a wide variety of industrial applications. Pressurized air is applied to a circular piston inside a cylinder which, by means of a rack and pinion gear, turns a shaft rendering rotary motion. This motion is transferred through the shaft to the application machinery which requires motion, such as a turntable, roll-over, tilting, indexing, transferring mixing, valve operating, tensioning and clamping.

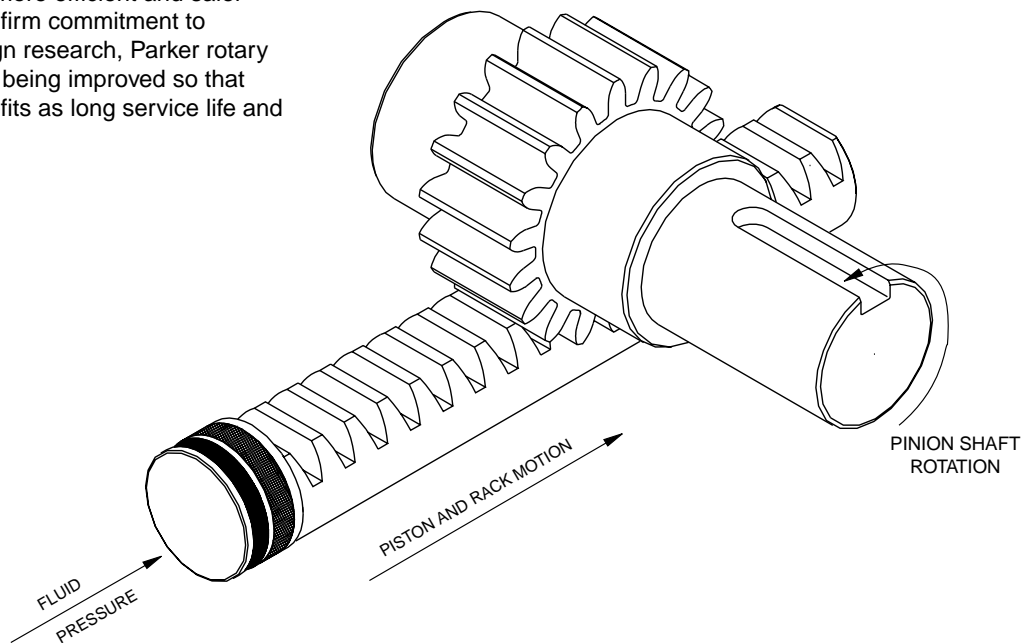

Why Use Parker Rotary Actuators?

- Wide range of sizes, worldwide.
- Provides uniform torque in both directions.
- Simplicity of design.
- High torque output in a thin package size.
- More efficient operation and longer time between servicing.
- Performs under the most adverse ambient conditions.
- No external linkage needed for rotary motion.
- Excellent holding capability with no drift.
- Optional cushions and shock absorbers can stop high inertial loads, eliminating external bracketry.
- Guaranteed zero external leakage.
- Will support substantial radial and thrust loads.

Where Can Parker Rotary Actuators Be Used?

- Material Handling
- Machine Tool
- Packaging
- Robotics
- Rubber and Plastics Machinery
- Valve Actuation
- Food Processing
- Semiconductor
- Conveyors
- Primary Metals

Rotary Actuators	PV
	WR
	XR
	PTR
	B671/F672
	HP

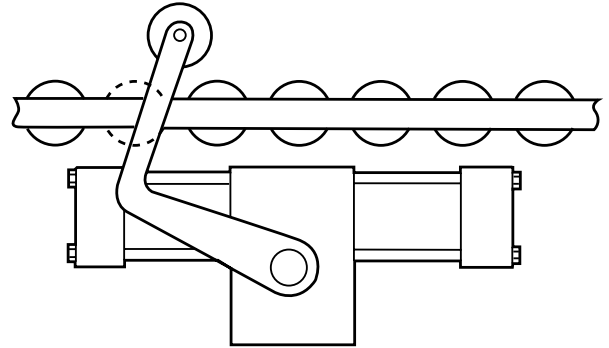
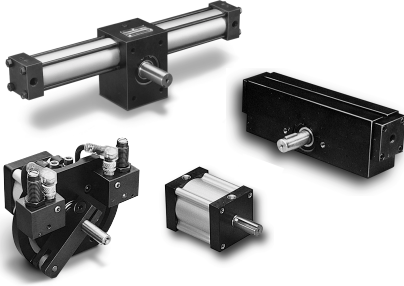

CONVEYOR STOP

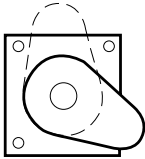

CAMMING

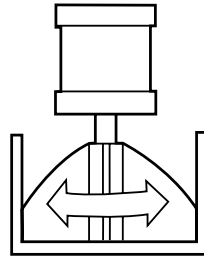

MIXING

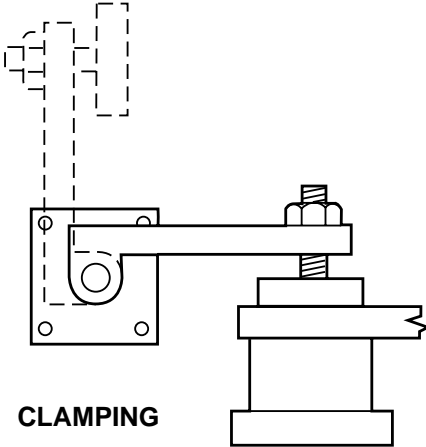

CLAMPING

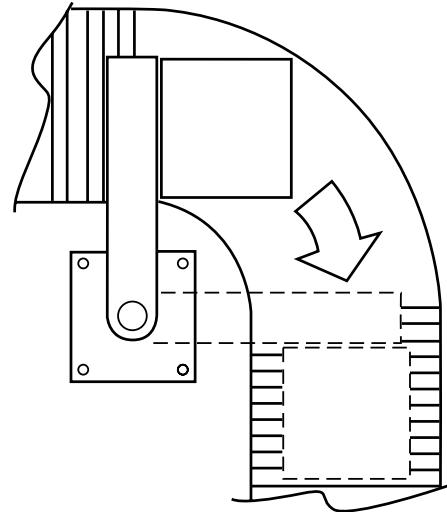

CONVEYOR TRANSFER

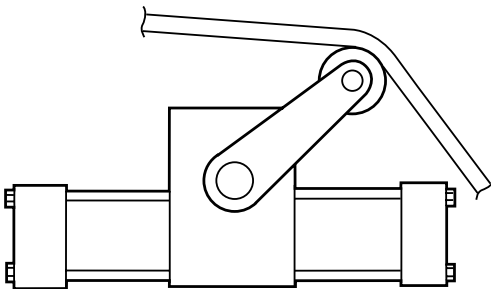

TENSIONING/SHOCK ABSORPTION

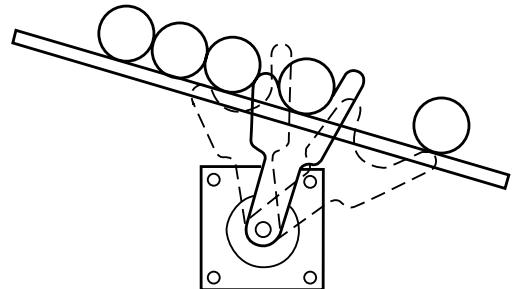

FEEDING

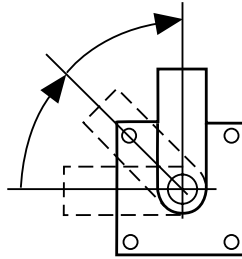
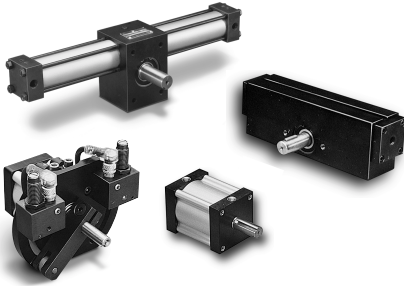

OPENING/CLOSING

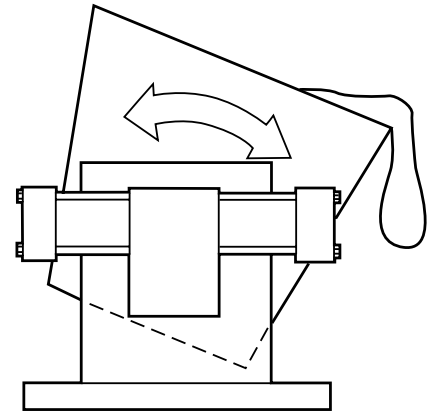

UNLOADING/DUMPING

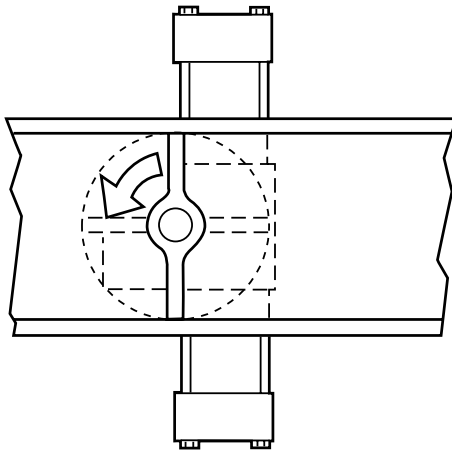

DAMPER CONTROL

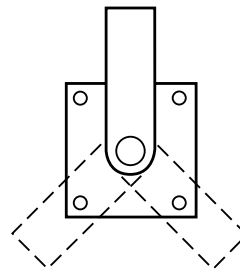

DIVERTING

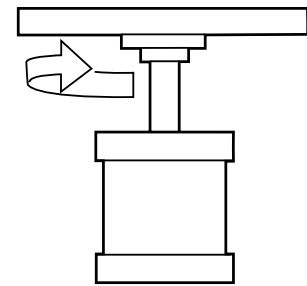

TURNTABLE/INDEXING

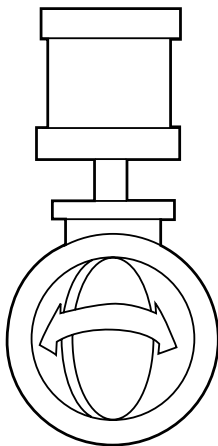

VALVE ACTUATION

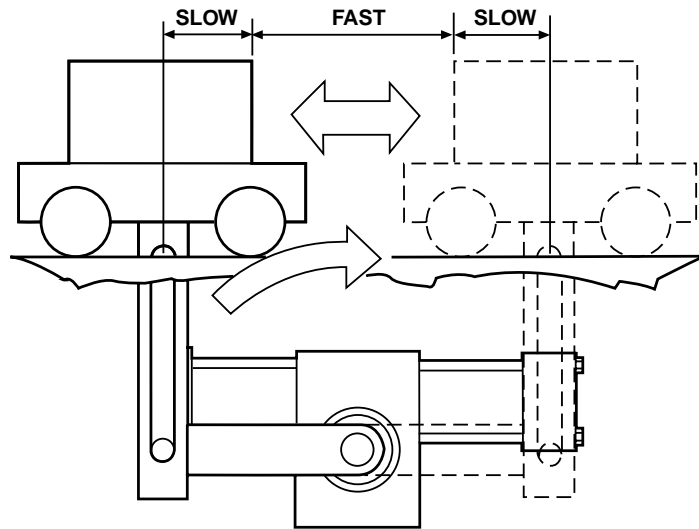

HARMONIC DRIVE

Rotary Actuators	PV
	WR
	XR
	PTR
	B671/F672
	HP

Design torque

Design torque represents the maximum torque that an actuator must supply in an application. This maximum is the greater of the Demand Torque or the Cushion Torque. If the demand torque exceeds what the actuator can supply, the actuator will either move too slowly or stall. If the cushion torque is too high, the actuator may be damaged by excessive pressure. Demand torque and cushion torque are defined below in terms of load, friction, and acceleration torque.

Equations for calculating demand torque and cushion torque for some general applications are provided on the following pages.

T - Torque

The amount of turning effort exerted by a rotary actuator.

T_D - Demand Torque

This is the torque required from the actuator to do the job and is the sum of the load torque, friction torque, and acceleration torque, multiplied by an appropriate design factor. Design factors vary with the applications and the designers' knowledge.

$$\text{Equation 4-3) } T_D = T_\alpha + T_f + T_L$$

T_L - Load torque

This is the torque required to equal the weight or force of the load. For example, in Fig. 4-8a, the load torque is 563 N•m (5000 lb-in.); in Fig. 4-8b the load torque is zero; in Fig. 4-8c the load torque is 563 N•m (5000 lb-in.). The load torque term is intended to encompass all torque components that aren't included in the friction or acceleration terms.

T_f - Friction torque

This is the torque required to overcome friction between any moving parts, especially bearing surfaces. In Fig. 4-8a, the friction torque is zero for the hanging load; in Fig. 4-8b the friction torque is 775 N•m (6880 lb-in) for the sliding load; in Fig. 4-8c the friction torque is zero for the clamp.

$$\text{Equation 4-4) } T_f = \mu Wr$$

T_a - Acceleration Torque

This is the torque required to overcome the inertia of the load in order to provide a required acceleration or deceleration. In Fig. 4-8a the load is suspended motionless so there is no acceleration. In Fig. 4-8b, the load is accelerated from

0 to some specified angular velocity. If the mass moment of inertia about the axis of rotation is I and the angular acceleration is a, the acceleration torque is equal to Ia. In Fig. 4-8c there is no acceleration.

Some values for mass moment of inertia are given in Table 4. Some useful equations for determining a are listed in Table 5. Equation 5 below shows the general equation for acceleration torque.

$$\text{Equation 4-5) } T_\alpha = I\alpha$$

T_C - Cushion Torque

This is the torque that the actuator must apply to provide a required deceleration. This torque is generated by restricting the flow out of the actuator (meter-out) so as to create a back pressure which decelerates the load. This back pressure (deceleration) often must overcome both the inertia of the load and the driving pressure (system pressure) from the pump. See applications.

$$\text{Equation 4-6) } T_C = T_{\alpha^*} + \frac{P_f V}{\theta} - T_f \pm T_L$$

The friction torque T_f reduces the torque the actuator must apply to stop the load. The load torque T_L may add to, or subtract from the torque required from the actuator, depending upon the orientation of the load torque. For example, a weight being swung upward would result in a load torque that is subtracted.

Warning: Rapid deceleration can cause high pressure intensification at the outlet of the actuator. Always insure that cushion pressure does not exceed the manufacturer's pressure rating for the actuator.

KE – Kinetic Energy (1/2 $J_m\omega^2$)

This is the amount of energy that a rotating load has. The rotator must be able to stop the load. All products have kinetic energy rating tables. Choose the appropriate deceleration option (i.e., bumper, cushions, shock absorbers, etc.) that meets or exceeds the kinetic energy of the load.

**Pages 6-8 excerpted from
the Parker Hannifin Design
Engineers Handbook.**

A) Example of load torque
The load is held motionless as shown.

$$T_D = T_\alpha + T_f + T_L$$

$$T_\alpha = 0$$

$$T_f = 0$$

$$T_L = (500 \text{ lb})(10 \text{ in}) = 5,000 \text{ lb} \cdot \text{in}$$

$$T_D = 5,000 \text{ lb} \cdot \text{in}$$

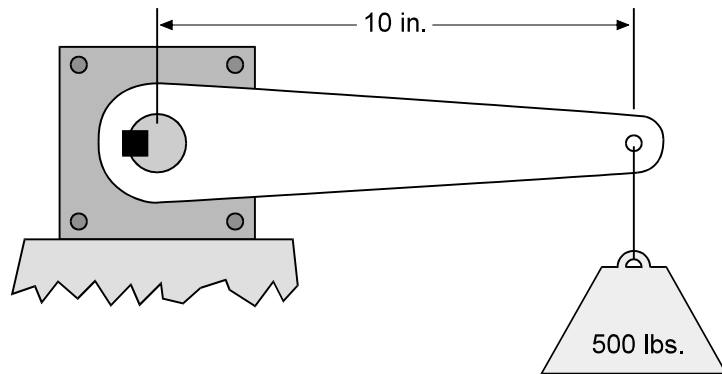

Figure 4-8aE

B.) Due to friction and acceleration

The 500 lb rotating index table is supported by bearings with a coefficient of friction of .25. The table's acceleration α is 2 rad/sec². The table's mass moment of inertia I is 2,330 lb-in-sec².

$$T_D = T_\alpha + T_f + T_L$$

$$T_\alpha = I\alpha = (2,330 \text{ lb} \cdot \text{in} \cdot \text{sec}^2)(2/\text{sec}^2) = 4,660 \text{ lb} \cdot \text{in}$$

$$T_f = \mu W r_b = .25(500 \text{ lb})(55 \text{ in}) = 6,880 \text{ lb} \cdot \text{in}$$

$$T_L = 0$$

$$T_D = 4,660 \text{ lb} \cdot \text{in} + 6,880 \text{ lb} \cdot \text{in} = 11,540 \text{ lb} \cdot \text{in}$$

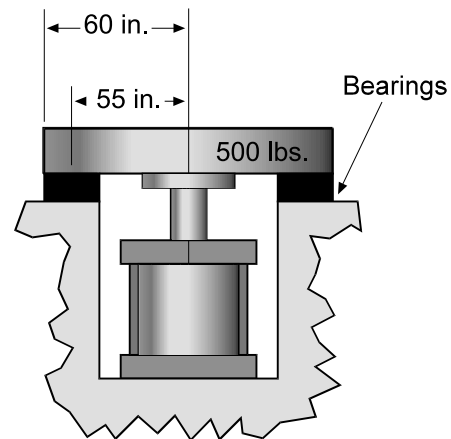

Figure 4-8bE

C.) Load torque example

$$T_D = T_\alpha + T_f + T_L$$

$$T_\alpha = 0$$

$$T_f = 0$$

$$T_L = (500 \text{ lb})(10 \text{ in}) = 5,000 \text{ lb} \cdot \text{in}$$

$$T_D = 5,000 \text{ lb} \cdot \text{in}$$

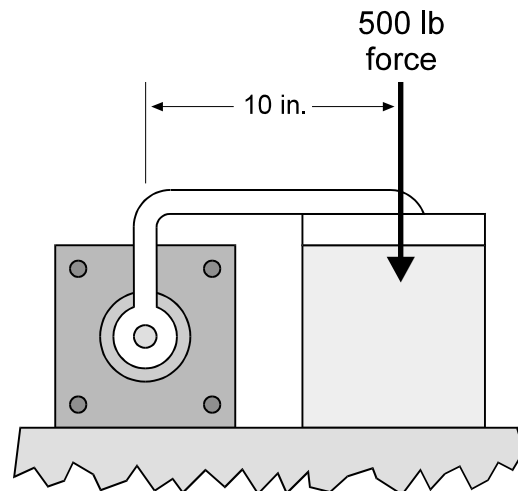
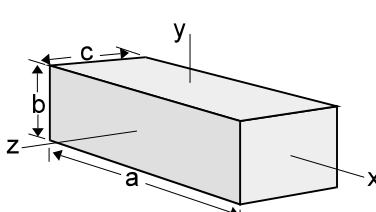
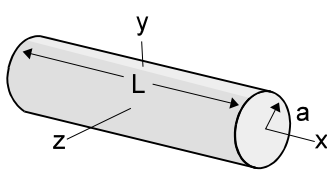
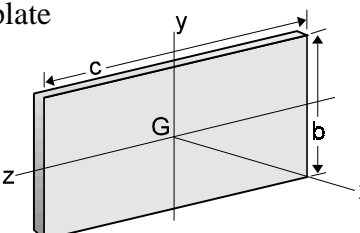
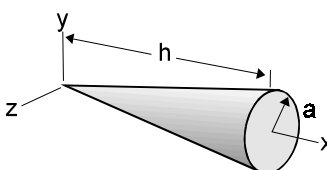
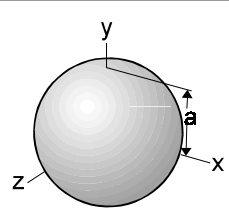
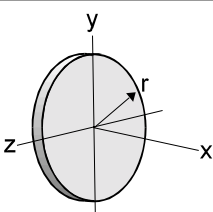
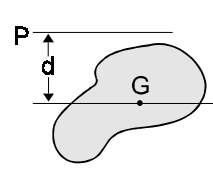

Figure 4-8cE

Rotary Actuators	PV
	WR
	XR
	PTR
	B671/F672
HP	

Table 4: Mass Moments of Inertia

<p>Rectangular prism</p>  $I_x = \frac{1}{12} m(b^2 + c^2)$ $I_y = \frac{1}{12} m(c^2 + a^2)$ $I_z = \frac{1}{12} m(a^2 + b^2)$	<p>Circular cylinder</p>  $I_x = \frac{1}{2} ma^2$ $I_y = I_z = \frac{1}{12} m(3a^2 + L^2)$
<p>Thin rectangular plate</p>  $I_x = \frac{1}{12} m(b^2 + c^2)$ $I_y = \frac{1}{12} mc^2$ $I_z = \frac{1}{12} mb^2$	<p>Circular cone</p>  $I_x = \frac{3}{10} ma^2$ $I_y = I_z = \frac{3}{5} m\left(\frac{1}{4}a^2 + h^2\right)$
<p>Sphere</p>  $I_x = I_y = I_z = \frac{2}{5} ma^2$	<p>Thin disk</p>  $I_x = \frac{1}{2} mr^2$ $I_y = I_z = \frac{1}{4} mr^2$
<p>Parallel Axis Theorem:</p>  $I_p = \bar{I} + md^2$	<p>I_p = Mass moment of inertia about an axis parallel to a centroidal axis. \bar{I} = Mass moment of inertia about a centroidal axis. m = Mass</p>
<p>When acceleration is constant:</p> $\theta = \omega_0 t + \frac{1}{2} \alpha t^2$ $\alpha = \frac{2\theta}{t^2}$ $\theta = \omega_0 t + \frac{1}{2} \omega_t t$ $\alpha = \frac{(\omega_t - \omega_0)^2}{2\theta}$ $\omega = \omega_0 + \alpha t$ $\alpha = \frac{(\omega_t - \omega_0)}{t}$ $\omega = (\omega_0^2 + 2\alpha\theta)^{1/2}$	<p>When velocity is constant:</p> $\theta = \omega t$ <p>t = time θ = angular position ω_t = angular velocity at time = t ω_0 = angular velocity at time = 0</p>

BASIC VELOCITY, ACCELERATION, KINETIC ENERGY AND TORQUE EQUATIONS

Equations below are based on triangular velocity profile.

$$\omega_{\max} = .035 \times \frac{\Theta}{t}$$

$$\alpha = \frac{\omega_{\max}^2}{\left(\frac{\Theta}{57.3}\right)}$$

$$\alpha = \frac{\omega_{\max}}{(t/2)}$$

$$\text{K.E.} = 1/2 J_m \omega^2$$

$$T_a = \alpha \times J_m$$

$$T_f = W \times U_s \times \left(\text{Distance from pivot point to center of external bearings}\right)$$

$$T_L = \left(\text{Torque arm length to C.G. of load}\right) \times W_L \times \cos(\phi)$$

Where ϕ = Angle between torque arm and horizontal plane

Where:

- Θ = Angle of Rotation (Degrees)
- t = Time to rotate through Θ (sec)
- ω = Angular velocity, radians/sec
- α = Angular accelerations (radians/sec²)
- W_L = Weight of load (lbf)
- T_a = Torque to accelerate load (lb-in)
- U_s = Coefficient of static friction
- J_m^* = Rotational mass moment of inertia (lb-in-sec²)
- T_f = Torque to overcome friction (lb-in)
- T_L = Torque to overcome effects of gravity

*Use "I" values from Table 4.

Rotary Actuators

PV
WR
XR
PTR
B671/F672
HP

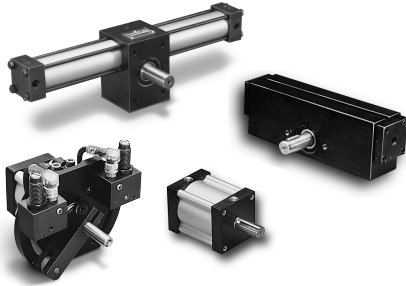

Torque Selection

Parker rotary actuators provide output torque up to 10,000 lb-in. The chart to the right shows the nominal torque output range of various actuator models at 100 PSI.

Caution:

This chart is intended as a guide only. Refer to actual product data in this catalog before specifying an actuator. Factors such as pressure rating, rotation, and actual torque output may be affected by specific product details and options.

Nominal Torque at 100 PSI

Output Torque, lb-in	Actuator Model, Rotation ≤ 95°		Actuator Model, Rotation >100°	
	Vane	Rack & Pinion	Vane	Rack & Pinion
10000		HP10		HP10
9000				
8000				
7000				
6000				
5000		HP4.5		HP4.5
4000				
3500				
3000		B6714		B6714
2500		PTR322		PTR322
2000	PV46D			
1750				
1500				
1250	PV44D	PTR321, B6713		PTR321, B6713
1000				
900		PTR252	PV46	PTR252
800				
700	PV36D, PV42D			
600		PTR202, B6712	PV44	PTR202, B6712
500	PV42D	PTR251		PTR251
400	PV33D		PV36	
300		PTR201	PV42	PTR201
250		PTR152, XR20		PTR152, XR20
200			PV33	
150	PV22D	PTR151, B6711		PTR151, B6711
100		XR15		XR15
80		PTR102	PV22	PTR102
60				
40		PTR101, XR10		PTR101, XR10
35	PV11D			
30				
25				
20	PV10D	XR07		XR07
15			PV11	
10		XR05	PV10	XR05
5				
0				

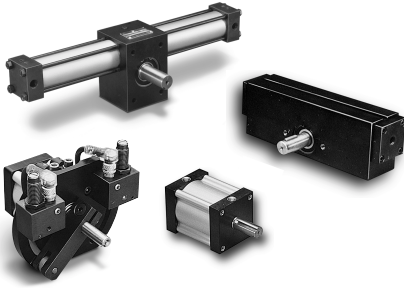

Performance Overview

Basic performance features of the rotator product line are shown below. See catalog sections for greater detail and ordering information.

Type		Vane		Rack & Pinion			
Series		PV	WR	XR	PTR	B671	HP
Standard Rotations		95°/100° ¹	210°	90°/100°	90°	90°	90°
		275°/280° ²		180°/190°	180°	180°	180°
				270°/280°	270°		
				360°/370°	360°	360°	360°
Maximum Torque at 100 psi (lb-in)		1800	65	236	2000	2500	10,000
Maximum Air Pressure Rating (psi)		150	150	150	250	140	100
Shaft Bearing Type		Ball or Thermo-plastic Bushing	Radial Ball Bushing	Radial Ball Bushing	Radial Ball Bushing	Bronze Bushing	Bronze Bushing
Non-Lube Service		●	●	●	●	●	●
Metric & Inch		●		C	●		
Switch Options	Hall Effect	●	C	●	●		
	Reed	●	C	●	●	C	
	Proximity sensor		●	C	●		●
Shaft Options	Double end	●		●	●		
	Female				●	●	●
	Preload keyway			●	●		
	Special	C	C	C	C	C	C
Rotation Options	Stroke adjust	●	●	●	●		●
	Cushions			●	●	●	●
	Bumpers	●	●	●	●		
	Shock absorbers		●	●	●		
Port Relocation		●		●	●	C	●
3-Position		C			●		
Air/Oil					●	● ³	
Zero Backlash		●	●	●	●		
Fluorocarbon Seals		●		●	●		●
Flange Mount		●			●		
Washdown		●		C	C		
Clean Room		●		C			



● = Available from catalog
C = Consult Factory

¹ Double vane
² Single vane
³ Hydro-check option



PV Series Vane Actuators

- 8 model sizes
- 2 standard rotations
- 7 to 1800 lb-in output torque at 100 PSIG

Single or double-vane actuators are permanently lubricated for trouble-free service and low breakaway. Unique construction provides high torque in a compact, lightweight package. Options include stroke adjusters, bumpers, rear porting, fluorocarbon seals, and magnets for Hall Effect or reed switches. Pressures to 150 PSIG.

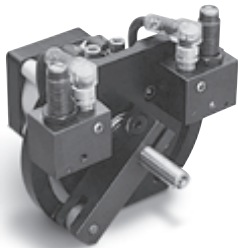

WR Series Wrist Rotate Units

- 2 models
- Adjustable rotation from 30° to 205°
- 15 and 65 lb-in output torque at 100 PSIG

Rugged actuators provide added features to allow use as a modular pick-and-place component or as a precision pneumatic rotary actuator. Features include hydraulic shock absorbers or polyurethane bumpers and optional plug-in style inductive proximity sensors.

XR Series Rack & Pinion Actuators

- 5 bore sizes from .56" to 2.00"
- 8 standard rotations
- 6 to 236 lb-in output torque at 100 PSIG

Economical compact, high-performance actuators offer rugged internal components packaged in a precision, unitized aluminum housing. Numerous options include bumpers, cushions, shock absorbers, stroke adjusters, reed and Hall Effect switches, flow controls and anti-backlash. Pressures to 150 PSIG.



PTR Series Rack & Pinion Actuators

- 5 bore sizes from 1" to 3-1/4"
- 5 standard rotations
- 39 to 2250 lb-in output torque at 100 PSIG

Rugged, reliable single or double-rack actuators provide superior performance with the broadest torque range in the industry. Proximity sensors, Hall Effect and reed switches are available for position sensing. A wide choice of options for unmatched application flexibility including three-position, anti-backlash and integral air/oil units are available. Pressures to 250 PSIG.

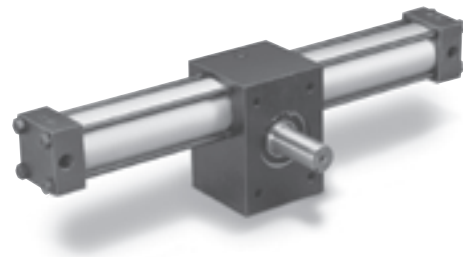

B671/F672 Actuators

- 4 bore sizes from 1-1/2" to 5"
- 100 to 2500 lb-in output torque at 100 PSI

Rugged design provides equal torque in both directions throughout the range of rotation. Can be coupled to a Hydrocheck for smooth, controlled motion. Prelubricated. Pressures to 140 PSI.

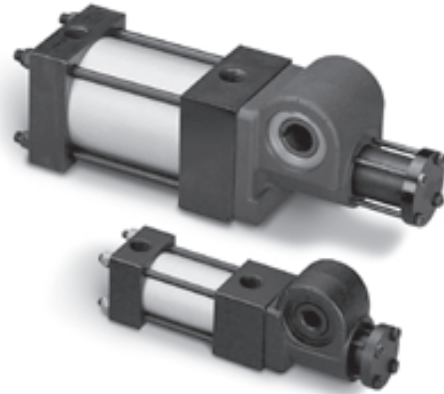

**HP Series
Rack & Pinion Actuators**

- 2 models
- 3 standard rotations
- 4,500 and 10,000 lb-in output torque at 100 PSIG

Rugged, large-bore actuators provide reliability in heavy-duty applications. Steel racks and pinions and a full range of options. Pressures to 100 PSIG.

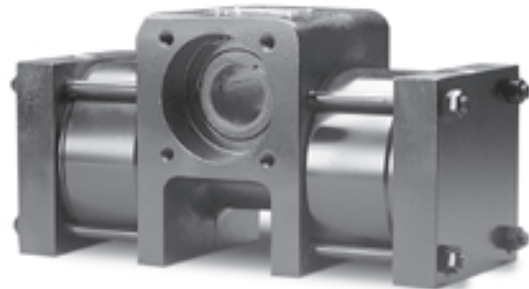

Rotary Actuators	PV
	WR
	XR
	PTR
	B671/F672
HP	