

COMPACT RESEATING RELIEF REGULATOR

Type A2CK-DN

FOR AMMONIA, R22, R134A, R502 AND
OTHER COMMON REFRIGERANTS

FEATURES

- Compact Direct Diaphragm Operated
- Design Pressure (PS): 406 PSIG (28 Bar)
- Flanged Connections: FPT, SW, WN or ODS
- Available with Close Coupled Strainer
- Complies with Pressure Equipment Directive 97/23/EC

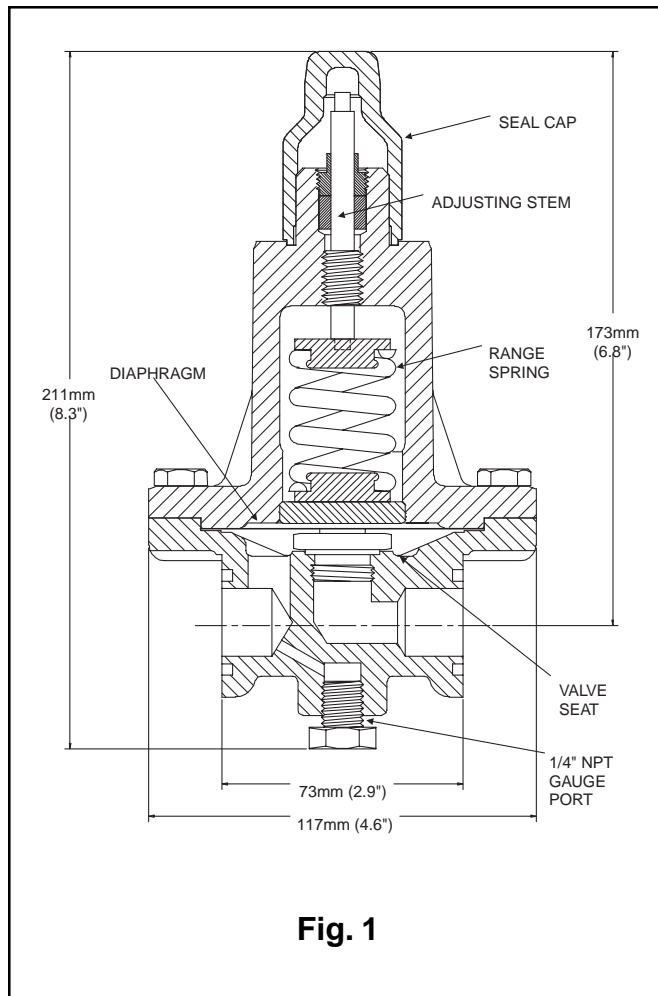

Description

The A2CK pressure relief regulator is a compact, direct diaphragm operated regulator for use with ammonia, R-22, R-134A, R-502, and other common refrigerants. The design pressure of the valve is 400 psig (27.6 bar). This regulator is used in systems where a small direct operated valve is required as a safety device to relieve "trapped" liquid lines in the event that a hydrostatic pressure condition develops.

BULLETIN DN21-03B

Type A2CK-DN



January 2007

Installation and Service Information

The regulators are furnished with flanges for FPT: Internal NPT (USA Standard Taper Pipe Thread), socket weld, weld neck or ODS (solders over copper tubing of given external diameter) connections. The regulator can be easily removed for service.

A strainer can be furnished to close couple the inlet of the regulator.

Purpose

The A2CK is a uniquely designed inlet pressure regulator intended for use as an "internal" pressure limiting device to prevent dangerous hydrostatic pressure conditions in cold liquid lines. **An A2CK should not be piped or applied as an ASME certified safety relief valve for use on pressure vessels.** Rather, the valve should be incorporated into a system where it is installed to relieve a section of liquid line which could inadvertently be isolated by service valves or automatic control valves. The regulator should be installed to relieve back to a low pressure (suction) side of the system. The A2CK utilizes a special pilot seat designed to provide for a higher flow rate (Cv) than the existing R/S A2BK relief regulator. Additionally, with a relatively small ratio of diaphragm to pilot seat area, it is designed to open and regulate refrigerant flow quickly through the pilot seat once its set point has been reached. The design of the valve allows for this "quick release" feature. However, it does not offer the same type of controlled response which may be required for a standard regulator application. For those applications where a small regulator is needed for accurate upstream pressure control, an R/S A2A or A2B direct operated regulator should be considered.

Principles of Operation

The inlet pressure acts on the diaphragm; when the force created by the pressure exceeds the force of the range spring, the diaphragm is lifted off of the valve seat and flow occurs from the regulator inlet to the outlet. Increased inlet pressure lifts the diaphragm farther, allowing increased flow. Decrease in inlet pressure causes the diaphragm to move closer to the

Item	Description	Part No.
3-5	Packing Kit	202100
3-6, 12-15	Spring/Stem kit	202007
1-6, 8, 11-16	Bonnet/Spring Kit	205758
17-18	Diaphragm Kit	200770
17-19	Seat Kit	205030
29	Gasket (12)	202078

Item	Description
1	Seal Cap
2	Gasket, Seal Cap
3	Nut, Stuffing Box
4	Packing Ring
5	Packing Washer
6	Adjusting Stem
8	Bonnet
9	Nameplate
10	Screw, Name Plate
11	Screw, Bonnet
12	Spring Rest, Upper
13	Spring, Range
14	Spring Rest, Lower
15	Diaphragm Follower
16	Gasket, Bonnet
17	Diaphragm
18	Gasket
19	Seat
20	Body
21	Plug
29	Gasket, Flange
30	Bolt
31	Nut
32	Flange

BOLT TORQUE TABLE		
ITEM	PORT SIZE	TORQUE
7/16" Flange bolt	1/2"	28 ft lb
5/16" - 18 Bonnet bolt	3/4" - 4"	15 ft lb

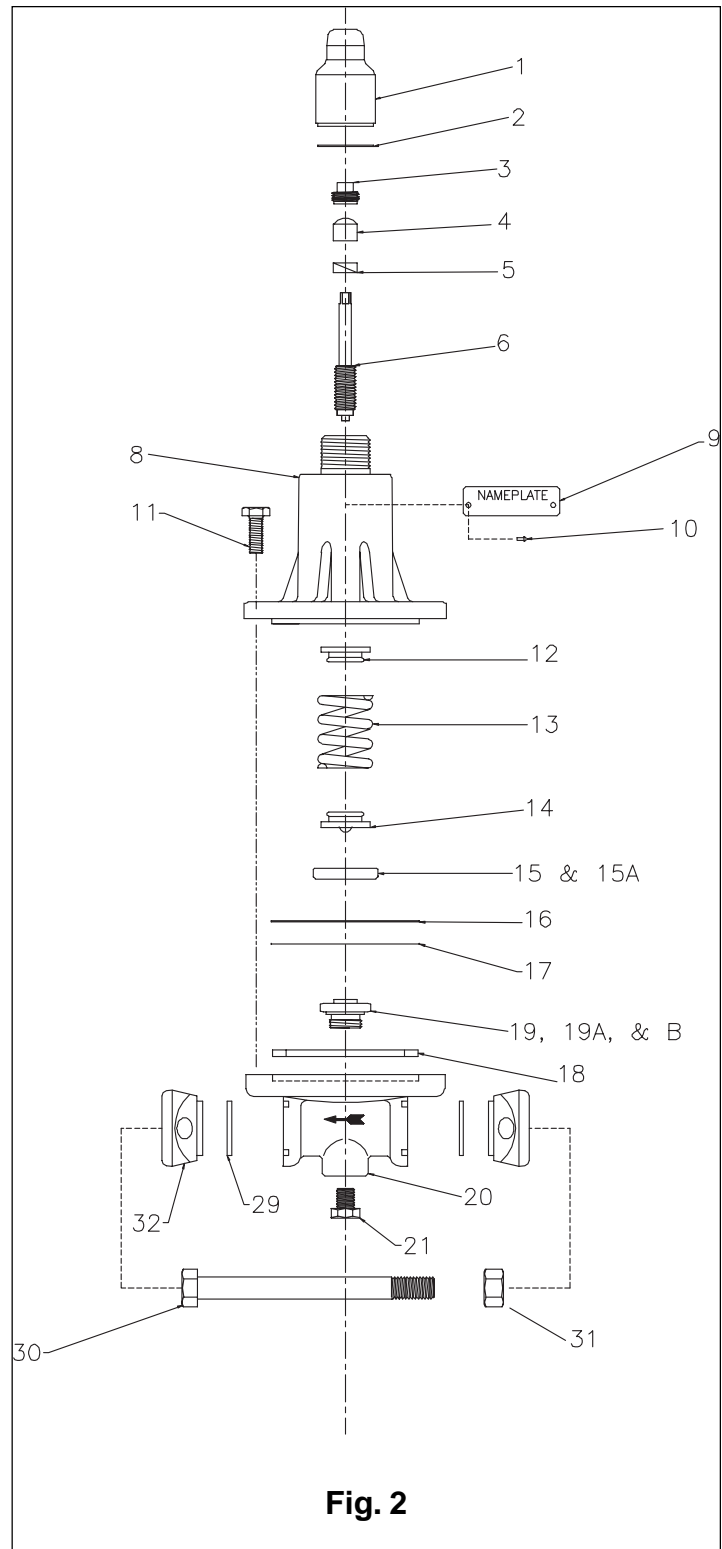

PRESSURE CONTAINING COMPONENTS A2CK DN LINE

	COMPONENT DESCRIPTION	MATERIAL
	BODY, A2C DN	DUCTILE IRON GGG 40.3
	BONNET, A4W	DUCTILE IRON GGG 40.3
	SEAL CAP, A4A	ALUMINUM ASTM SC84B

valve seat, thus reducing the flow. Once the inlet pressure drops below the regulator setting, the diaphragm closes off flow, subject to limits of the seat leakage tolerance, which is held to a minimum with the pilot seat design.

Factory Setting

The A2CK is factory set and sealed with a lead seal prior to shipment. Since the valve should be used exclusively as a small internal relief valve, it is designed with the R/S range "D" adjusting spring only. Set points are based on customer requirements, but need to fall within the 75 to 280 psig (5 to 19 bar) range covered by the range "D" adjusting spring. For low side (evaporator pressure regulator) applications please refer to bulletin DN21-02 covering the A2A-DN or A2B-DN pressure regulators.

In the event that the seal is broken, or the valve is being serviced, and a confirmation of the valves set point is required, the approximate change in pressure per full turn of the adjusting screw is 53 psi (3.6 bar).

Disassembly and Assembly

Refer to Fig. 2 for the parts discussed in this section.

Before disassembling or assembling a regulator, read the information in this bulletin and Bulletin RSBCV, Safety Procedures for R/S Refrigeration Control Valves.

Before a regulator is removed from the line or disassembled in the line, make sure that all refrigerant has been removed from the regulator, and the regulator is isolated from the rest of the system in a safe manner.

Disassembly – Remove Seal Cap 1 and back out the Adjusting Stem 6 to remove all tension from the Range Spring 13. This is necessary to avoid possible damage to internal parts of the regulator. Remove Bonnet Screws 11 and disassemble parts 12 through 18 as shown in Fig. 2. Normally parts 3 through 6 do not require disassembly. Inspect parts for dirt, corrosion and wear and clean or replace as needed. Inspect the Valve Seat 19 top seating surface for dirt, wear or damage. Remove from valve body and clean, lap on a flat plate or replace as necessary. Examine the diaphragm region which contacts the seat surface; look for dirt, heavy scratches or corrosion. If the diaphragm cannot be easily wiped clean it should be replaced. Gaskets should be replaced whenever a regulator is reassembled.

Assembly – When assembling the regulator, lightly oil the gaskets with refrigerant oil. Make sure all parts are free of dirt and moisture condensate. Dry the parts if necessary and oil lightly. All gaskets must be properly aligned. Arrange the parts as shown in Fig. 2 making sure the Diaphragm Follower 15 is properly located in the Bonnet 8. The diaphragm must be installed with the raised center portion towards the bonnet. The design of this regulator employs a single stainless steel diaphragm with the range "D" spring. Tighten the Bonnet Screws 11 gradually and evenly. The screws should be tightened by turning opposing screws alternately rather than in a circular pattern. The ideal tightening torque is 11 lbs.-ft (1.5 kg-m).

After the regulator is assembled and reinstalled, check all

external joints for leaks. Adjust the regulator spring to the proper set point by turning the adjusting stem recognizing that one complete turn of the stem results in a pressure (set point) increase of about 53 psi (3.6 bar).

Installation

Do not remove the protective covering from the A2CK regulator until it is ready to be installed. Protect the inside of the regulator from moisture, dirt and chips before and during installation. When welded or brazed flange connections are used, all slag, scale and loose particles should be removed from the flange interior before the regulator is installed between the flanges.

Tighten flange bolts and nuts evenly to provide proper seating of the flange gasket and to avoid damage to gasket or flanges. **A close coupled companion strainer is available and recommended for installation at the inlet of the regulator to help to protect it from any foreign material in the system.**

The regulator must be installed with the arrow on the valve body pointing in the direction of the flow for the regulator to function properly. The regulator should be installed in a location where it is easily accessible for maintenance. The location should be such that the regulator cannot be easily damaged by material handling equipment. When it is necessary to insulate the regulator (and companion strainer), the insulation should be installed to provide access to the regulator (and companion strainer) for adjustment and maintenance.

Safe Operation (See also Bulletin RSBCV)

People doing any work on a refrigeration system must be qualified and completely familiar with the system and the Refrigerating Specialties Division valves involved, or all other precautions will be meaningless. This includes reading and understanding pertinent Refrigerating Specialties Division product Bulletins and Safety Bulletin RSB prior to installation or servicing work.

Where cold refrigerant liquid lines are used, it is necessary that certain precautions be taken to avoid damage that could result from liquid expansion. Temperature increase in a piping section full of solid liquid will cause high pressure due to the expanding liquid that can possibly rupture a gasket, pipe or valve. All hand valves isolating such sections should be marked, warning against accidental closing, and must not be closed until the liquid is removed. Check valves must never be installed upstream of solenoid valves, or regulators with electric shut-off, nor should hand valve upstream of solenoid valves or downstream of check valves be closed until the liquid has been removed. It is advisable to properly install relief devices such as A2CK in any section where liquid expansion could take place.

Avoid all piping or control arrangements that might produce thermal or pressure shock. For the protection of people and products, all refrigerant must be removed from the section to be worked on before a valve, strainer, or other device is opened or removed. Flanges with ODS connections are not suitable for ammonia service.

Warranty

All Refrigerating Specialties products are warranted against defects in workmanship and materials for a period of one year from date of shipment from originating factory. This warranty is in force only when products are properly installed, field assembled, maintained, and operated in use and service as specifically stated in Refrigerating Specialties Catalogs or Bulletins for normal refrigeration applications, unless otherwise approved in writing by Refrigerating Specialties Division. Defective products, or parts thereof returned to the factory with transportation charges prepaid and found to be defective by factory inspection will be replaced or repaired at Refrigerating Specialties option, free of charge F.O.B. factory. Warranty does not cover products that have been altered, or repaired in the field; damaged in transit, accidents, misuse, or abuse. Products disabled by dirt or other foreign substances will not be considered defective.

The express warranty above constitutes the only warranty of Refrigerating Specialties products, and is in lieu of all other warranties, expressed or implied, written or oral, including any warranty of merchantability or warranty of fitness for a particular purpose and in no event is Refrigerating Specialties responsible for any consequential damages of any nature whatsoever. No employee, agent, dealer or other person is authorized to give any warranties on behalf of Refrigerating Specialties nor to assume for Refrigerating Specialties any other liability in connection with any of its products.